



INTERNATIONAL APPLICATION PUBLISHED UNDER THE PATENT COOPERATION TREATY (PCT)

(51) International Patent Classification ⁶ : B60R 21/20	A1	(11) International Publication Number: WO 00/06426 (43) International Publication Date: 10 February 2000 (10.02.00)
<p>(21) International Application Number: PCT/JP99/04121</p> <p>(22) International Filing Date: 30 July 1999 (30.07.99)</p> <p>(30) Priority Data: 10/217465 31 July 1998 (31.07.98) JP</p> <p>(71) Applicant (for all designated States except US): NHK SPRING CO., LTD. [JP/JP]; 10, Fukuura 3-chome, Kanazawa-ku, Yokohama-shi, Kanagawa 236-0004 (JP).</p> <p>(72) Inventors; and (75) Inventors/Applicants (for US only): MIZOBUCHI, Susumu [JP/JP]; 1644-3, Dainogocho, Ota-shi, Gumma 373-0801 (JP). WATANABE, Toshiyasu [JP/JP]; 800, Motegicho, Ota-shi, Gumma 373-0809 (JP).</p> <p>(74) Agents: SUZUYE, Takehiko et al.; Suzuye & Suzuye, 7-2, Kasumigaseki 3-chome, Chiyoda-ku, Tokyo 100-0013 (JP).</p>		<p>(81) Designated States: US, European patent (DE, GB, IT).</p> <p>Published With international search report. Before the expiration of the time limit for amending the claims and to be republished in the event of the receipt of amendments.</p>

(54) Title: AIR-BAGGED SEAT

(57) Abstract

A cover member (25) for covering an air bag storage portion (22a) of a seat back (22) is formed by sewing up a seat-back front cover element (25a), side cover element (25b), etc. An air bag module (30) is stored in a module container (50) that is located in the air bag storage portion (22a). The module container (50), which is formed of a flexible sheetlike material, includes two opposite side portions (50a, 50b), which extend individually along two opposite side faces of the air bag module (30), and a rear end portion (50c), which extends along the rear end face of the air bag module (30). Front end portions (51) of the module container (50) are sewn together with the seat-back front cover element (25a) and the side cover element (25b) in a sewing portion (40) between the cover elements (25a, 25b). The sewing portion (40) and the front end portions (51) of the module container (50) open when the air bag (30) inflates.

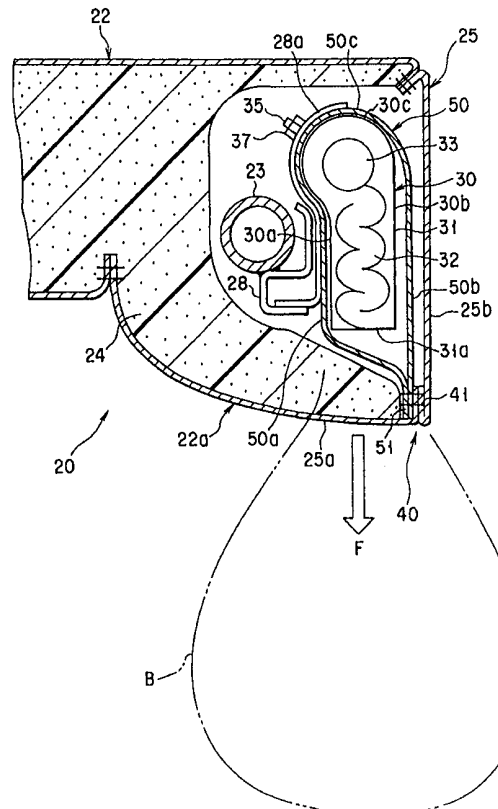

FOR THE PURPOSES OF INFORMATION ONLY

Codes used to identify States party to the PCT on the front pages of pamphlets publishing international applications under the PCT.

AL	Albania	ES	Spain	LS	Lesotho	SI	Slovenia
AM	Armenia	FI	Finland	LT	Lithuania	SK	Slovakia
AT	Austria	FR	France	LU	Luxembourg	SN	Senegal
AU	Australia	GA	Gabon	LV	Latvia	SZ	Swaziland
AZ	Azerbaijan	GB	United Kingdom	MC	Monaco	TD	Chad
BA	Bosnia and Herzegovina	GE	Georgia	MD	Republic of Moldova	TG	Togo
BB	Barbados	GH	Ghana	MG	Madagascar	TJ	Tajikistan
BE	Belgium	GN	Guinea	MK	The former Yugoslav Republic of Macedonia	TM	Turkmenistan
BF	Burkina Faso	GR	Greece			TR	Turkey
BG	Bulgaria	HU	Hungary	ML	Mali	TT	Trinidad and Tobago
BJ	Benin	IE	Ireland	MN	Mongolia	UA	Ukraine
BR	Brazil	IL	Israel	MR	Mauritania	UG	Uganda
BY	Belarus	IS	Iceland	MW	Malawi	US	United States of America
CA	Canada	IT	Italy	MX	Mexico	UZ	Uzbekistan
CF	Central African Republic	JP	Japan	NE	Niger	VN	Viet Nam
CG	Congo	KE	Kenya	NL	Netherlands	YU	Yugoslavia
CH	Switzerland	KG	Kyrgyzstan	NO	Norway	ZW	Zimbabwe
CI	Côte d'Ivoire	KP	Democratic People's Republic of Korea	NZ	New Zealand		
CM	Cameroon			PL	Poland		
CN	China	KR	Republic of Korea	PT	Portugal		
CU	Cuba	KZ	Kazakstan	RO	Romania		
CZ	Czech Republic	LC	Saint Lucia	RU	Russian Federation		
DE	Germany	LI	Liechtenstein	SD	Sudan		
DK	Denmark	LK	Sri Lanka	SE	Sweden		
EE	Estonia	LR	Liberia	SG	Singapore		

a signal that is delivered by a sensor when the vehicle is subjected to a side impact. An air bag 6 can be inflated with this gas.

The seat back 2 includes a frame 7, pad 8, cover member 9, etc. The cover member 9 is composed of a seat-back front cover element 9a, a side cover element 9b, etc. As the air bag 6 unfolds, sewing thread 11 in a sewing portion 10 between the seat-back front cover element 9a and the side cover element 9b is broken by pressure that acts thereon from inside the cover member 9. The air bag 6 bulges ahead of the seat back 2 (in the direction indicated by arrow F) through the broken portion, as indicated by two-dot chain line A. The air bag 6 unfolds into a shape such that it can protect the flank, temple, etc. of the user. A lid 4a is provided on the front part of the air bag module 4.

While the air bag 6 breaks the lid 4a as it unfolds, the unfolding direction of the air bag 6 is subject to variation in some cases. It is to be desired that the air bag 6 should unfold toward the sewing portion 10. Possibly, however, the air bag 6 may fail to unfold toward the sewing portion 10 from various causes associated with variations in the structures of the lid 4a, inflator 5, etc. When the air bag 6 unfolds, moreover, the seat-back front cover element 9a and the side cover element 9b sometimes

may behave so as to inflate as a whole. In this case, the unfolding force of the air bag 6 cannot easily act on the sewing portion 10, so that the seat-back front cover element 9a and the side cover element 9b themselves may possibly be broken.

Accordingly, the object of the present invention is to provide an air-bagged seat designed so that an air bag can spread out from an expected portion to be broken as the air bag unfolds, thus ensuring proper unfolding performance.

Disclosure of Invention

According to the present invention, there is provided an air-bagged seat comprising an air bag module in a seat back, in which a cover member for covering an air bag storage portion of the seat back is formed by sewing up at least a first cover element (e.g., seat-back front cover element) and a second cover element (e.g., side cover element). The air bag module is stored in a belt- or bag-shaped module container having a pair of opposite side portions, right and left, and a rear end portion. Front end portions of the opposite side portions of the module container are sewn together with the first and second cover elements in a sewing portion between the cover elements. Preferably, the module container is formed of a material that is as flexible as cloth and is more resistant to tension (or has higher tensile strength)

than the first and second cover elements.

When the air-bagged seat according to the present invention is subject to a force of impact, an inflator is actuated, whereupon gas is jetted out to inflate the air bag, and pressure acts from inside the cover member. The unfolding force of the air bag acts on the module container in the initial stage of the unfolding action of the air bag. Since the material of the module container is stouter than the cover member (first and second cover elements), so that the module container itself cannot be broken.

Thus, the air bag is guided by the opposite side portions of the module container as it unfolds toward the front end portion of the module container or the sewing portion of the cover member, whereby sewing thread or the like in the sewing portion is broken. Accordingly, the air bag unfolds steadily in a regular direction, so that the shock of a second collision between a user and interior members can be eased. The air bag stated herein is a member that can be inflated like a bag with gas, such as nitrogen gas. It is to be understood that the gas to be used for inflation is not limited to nitrogen or air.

According to this invention, the unfolding direction of the air bag can be regulated by means of the module container when the air bag unfolds, so that the air bag can be unfolded toward a predetermined

expected portion to be broken. Thus, the air bag can
enjoy a stable unfolding direction and display proper
unfolding performance. This module container is a
belt- or bag-shaped structure of a flexible pliable
5 material that is sewn together with conventional
cover elements in the same spot as the sewing portion
of a conventional cover member. Although the module
container is sewn to the sewing portion, therefore,
the sewing portion cannot be externally conspicuous
10 and never exerts a bad influence upon the external
appearance of the seat back.

Preferably, the module container has holes through
which bolts for fixing the air bag module to a seat
back frame are passed individually. It is advisable
15 to fix the air bag module and the module container
to the seat back frame with the bolts in the holes.
According to this invention, the module mounting bolts
are passed individually through the holes in the module
container, so that the holes and the bolts can be
20 utilized as positioning means for the module container.
Accordingly, there is no possibility of either of
the opposite side portions of the module container
undergoing deviation, such as strain or skew, after
sewing operation. Since the module container is
25 laterally balanced as it is located on either side of
the air bag module, the unfolding direction of the air
bag can be made steadier.

Preferably, the module container according to this invention should have a shape such that a bottom portion and the rear end portion between the opposite side portions are closed, and that the top portion and the front end portions of the opposite side portions can be opened when the air bag unfolds. According to this invention, the front end portions and the top portion of the module container are opened when the air bag unfolds, so that the air bag can be unfolded forward and upward with respect to the seat back.

Each of the front end portions of the module container may be provided with a seam length adjusting portion for adjusting the seam length of the module container sewn to the cover member. According to this invention, the seam length of the sewing portion at the front end portions of the module container is reduced, so that the sewing portion of the module container can be made easily breakable when the air bag unfolds. Accordingly, the unfolding action of the air bag in a predetermined position can be made steadier.

Additional objects and advantages of the invention will be set forth in the description which follows, and in part will be obvious from the description, or may be learned by practice of the invention. The objects and advantages of the invention may be realized and obtained by means of the instrumentalities and combinations particularly pointed out hereinafter.

Brief Description of Drawings

The accompanying drawings, which are incorporated in and constitute a part of the specification, illustrate presently preferred embodiments of the invention, and together with the general description given above and the detailed description of the preferred embodiments given below, serve to explain the principles of the invention.

FIG. 1 is a partial cross-sectional view of an air-bagged seat according to a first embodiment of this invention;

FIG. 2 is a perspective view of the air-bagged seat shown in FIG. 1;

FIG. 3 is an exploded perspective view of part of the air-bagged seat shown in FIG. 1;

FIG. 4 is a perspective view showing an unfolded state of an air bag of the air-bagged seat shown in FIG. 1;

FIG. 5A is a sectional view of a sewing portion of a air-bagged seat according to a second embodiment of this invention;

FIG. 5B is a sectional view of a sewing portion of a air-bagged seat according to a third embodiment of this invention;

FIG. 6 is a perspective view of a module container according to a fourth embodiment of this invention;

FIG. 7A is a side view of a module container

according to a fifth embodiment of this invention;

FIG. 7B is a side view of a module container
according to a sixth embodiment of this invention;

FIG. 7C is a side view of a module container
5 according to a seventh embodiment of this invention;
and

FIG. 8 is a cross-sectional view of part of a
conventional air-bagged seat.

Best Mode of Carrying Out the Invention

10 A first embodiment of this invention will now be
described with reference to FIGS. 1 to 4.

A side-air-bagged seat 20 shown in FIG. 2, which
is applied to a front seat of an automobile, is
provided with a seat cushion 21 and a seat back 22.
15 As shown in FIG. 1, the seat back 22 is provided
with a seat back frame 23, a pad 24 formed of, e.g.,
polyurethane foam, and a cover member (front seat trim
cover) 25 that externally covers the seat back frame 23,
pad 24, etc. A bracket 28 is fixed to the lateral
20 of the seat back frame 23 by welding or the like.
The bracket 28 includes a mounting plate 28a having
a shape such that it extends along an air bag module 30
described below.

The air bag module 30, which constitutes a side
25 air bag system, is incorporated in one of two opposite
side portions 22a and 22b of the seat back 22, that is,
the side portion 22a that is nearer to a door. The air

bag module 30 is provided with a casing 31 fixed to the mounting plate 28a of the bracket 28 of the seat back frame 23, an air bag 32 folded and stored in the casing 31, an inflator 33 for generating inflator gas such as nitrogen gas, etc.

In the case of this embodiment, as shown in FIG. 3 and the like, bolts 35 protrude from the casing 31 of the air bag module 30. The bolts 35 are passed individually through holes 36 that are formed in the mounting plate 28a. The air bag module 30 is fixed in a predetermined position on the bracket 28 by fastening nuts 37 individually to the bolts 35 in an engaged manner. The casing 31 functions also as a guide member for regulating the direction in which the inflator gas is jetted out. A lid 31a is provided on the front part of the casing 31. Further, the inflator 33 is connected with an ignition system, which includes a sensor for detecting a side impact of a vehicle, a power source (not shown), etc.

The cover member 25, which constitutes a seat back covering, is formed by cutting a flexible cover element of artificial leather or woven fabric into a given shape and sewing it. An example of artificial leather is obtained by coating the outer surface of knitted fabric for use as a back fabric base with an elastic material such as an elastomer layer. The cover member 25, which covers the side portion 22a that functions as

an air bag storage portion, includes a seat-back front cover element 25a for use as a first cover element according to this invention and a side cover element 25b as a second cover element. The seat-back front cover element 25a constitutes the front face of the side portion 22a. The side cover element 25b constitutes the side face of the side portion 22a. These cover elements 25a and 25b are sewn together at a sewing portion 40 by means of sewing thread 41.

The air bag module 30 is fixed to the mounting plate 28a of the bracket 28 in a manner such that it is stored inside a belt-shaped module container 50 illustrated in FIG. 3. The module container 50 according to this embodiment is formed of a flexible sheetlike material that has higher tensile strength and impact resistance than the seat-back front cover element 25a and the side cover element 25b. A pair of opposite side portions 50a and 50b, which extend along two opposite side faces 30a and 30b, respectively, of the air bag module 30, and a rear end portion 50c, which extends along a rear end face 30c of the air bag module 30, are formed by turning up the sheetlike material in the shape of a U.

Open front end portions 51 of the opposite side portions 50a and 50b of the module container 50 are sewn together with the seat-back front cover element 25a and the side cover element 25b at the sewing

portion 40 between the cover elements 25a and 25b
by means of the sewing thread 41. The module
container 50, which need not be of any special material,
may be formed of woven or nonwoven fabric based on
5 flexible synthetic fibers with high tensile strength.
Alternatively, it may be formed of a synthetic resin
sheet with high tensile strength. In order to enhance
its longitudinal tensile strength, moreover, the module
container 50 may be reinforced with fine metal wires,
10 aramid fibers, or other reinforcing materials that have
tensile strength high enough but not too high for the
maintenance of flexibility. As shown in FIG. 3, the
module container 50 is formed having holes 55 through
which the bolts 35 are passed individually.

15 In attaching the air bag module 30 to the seat
back frame 23, the front end portions 51 of the module
container 50 are previously sewn together with the
seat-back front cover element 25a and the side cover
element 25b at the sewing portion 40 between the cover
20 elements 25a and 25b. The air bag module 30 is
interposed between the opposite side portions 50a and
50b of the module container 50, and the bolts 35 are
passed individually through the holes 55 of the module
container 50.

25 Then, the air bag module 30 is attached to
the bracket 28 in a manner such that the bolts 35
are passed individually through the holes 36 of

the bracket 28 and the nuts 37 are fastened from behind
the bracket 28. By doing this, the air bag module 30
and the module container 50 are fixed in one united
body to the seat back frame 23. Since the module
5 container 50 according to this embodiment has its
top and bottom open, the air bag module 30 can be
put inside the module container 50 even after the front
end portions 51 are sewn to the cover member 25.

The following is a description of the operation of
10 the air-bagged seat 20 that is provided with the air
bag module 30 and the module container 50.

When the vehicle is subjected to a lateral force
of impact, the inflator 33 is actuated in response
to a signal delivered from the sensor for detecting
15 a collision of the vehicle, whereupon the inflator
gas such as nitrogen gas is jetted out from the
inflator 33. The jetted gas is ejected into the air
bag 32 in a manner such that the direction of its
ejection is regulated by the casing 31.

20 When the air bag 32 starts to be inflated with
the ejected gas from the inflator 33, the lid 31a
is broken, and the air bag 32 unfolds ahead of the
casing 31. As the air bag 32 unfolds in this manner,
the air bag 32 unfolds toward the front end portions 51
25 of the module container 50, that is, toward the sewing
portion 40 between the seat-back front cover element
25a and the side cover element 25b, in a manner such

that its unfolding direction is regulated by the
opposite side portions 50a and 50b of the module
container 50. Pressure from this unfolding action
acts on the sewing portion 40 from behind the cover
5 member 25.

In this case, the behavior of the air bag 32
moving toward the side cover element 25b can be
restrained by means of the side portion 50b of the
module container 50. Thus, the side cover element 25b
10 can be effectively prevented from breaking, and the
unfolding force of the air bag 32 acts directly on
the sewing thread 41 in the sewing portion 40.

Accordingly, the sewing thread 41 in the sewing
portion 40 breaks without fail. As indicated by
15 two-dot chain line B in FIG. 1, the air bag 32 mainly
spreads out forward and upward in the direction
indicated by arrow F from the broken sewing portion 40.
FIG. 4 shows an unfolded state of the air bag 32.
The air bag 32 thus unfolded is located in a space
20 between the flank of a seated user's body and an inner
side wall of the vehicle body, whereby the shock of
a second collision between the user and the inner side
wall of the vehicle body can be eased.

In this embodiment, the module mounting bolts 35
25 are passed individually through the holes 55 in the
module container 50, so that the holes 55 and the
bolts 35 can be utilized as positioning means for

the module container 50. When the module container 50 is sewn together with the sewing portion 40 of the cover member 25, according to the embodiment arranged in this manner, the opposite side portions 50a and 50b
5 of the module container 50 can be arranged on the opposite sides of the air bag module 30 uniformly and satisfactorily without the possibility of either of the opposite side portions 50a and 50b undergoing deviation, such as strain or skew. Accordingly, the air bag 32
10 can be guided in a steadier unfolding direction by the opposite side portions 50a and 50b of the module container 50 as the air bag 32 unfolds.

FIG. 5A shows a second embodiment of the present invention. In the case of this embodiment, front end
15 portions 51 of two opposite side portions 50a and 50b of a module container 50 are situated on either side of a sewing portion 40 between a seat-back front cover element 25a and a side cover element 25b. The cover elements 25a and 25b are sewn up in one united body
20 with the sewing portion 40 between them held by means of the front end portions 51 from both sides.

FIG. 5B shows a third embodiment of the present invention. In the case of this embodiment, a seat-back front cover element 25a, a side cover element 25b, and
25 two opposite side portions 50a and 50b of a module container 50 are sewn together in a manner such that they are put on one another, as indicated by two-dot

chain line in the drawing. Thereafter, the cover elements 25a and 25b and the opposite side portions 50a and 50b of the module container 50 are turned up, as indicated by arrows C and D. These steps of procedure
5 further facilitate the sewing operation.

The cover member 25 that covers the side portion 22a for use as the air bag storage portion may be formed by combining the seat-back front cover element 25a, side cover element 25b, and other cover elements.
10 The module container 50 may be in the form of a bag. In this case, an open edge portion of the bag is sewn together with the sewing portion 40. The bag-shaped module container may be formed by blow molding or by sewing cloth into the form of a bag, for example.

15 A module container 50 according to a fourth embodiment shown in FIG. 6 is in the form of a bag, in which a rear end portion (back surface) 50c between a pair of side portions 50a and 50b, right and left, is closed, a bottom portion 50e is closed, and the top
20 side is open. By forming the module container 50 like this bag, front end portions 51 and the top side of the module container 50 may be designed to be opened when the air bag unfolds. In the case of this embodiment, the air bag can be unfolded forward and upward with
25 respect to the seat back. Since the top side of the module container 50 is also open in this case, an air bag module 30 can be introduced into the module

container 50 without any problem even after the front end portions 51 are sewn to a sewing portion 40.

In a module container 50 according to a fifth embodiment shown in FIG. 7A, each of front end portions 51 of the module container 50 is provided with a seam length adjusting portion 60 for adjusting the seam length of the module container 50 in a sewing portion 40. An example of the seam length adjusting portion 60 is tapered so that a vertical width W1 of the front end portions 51 is shorter than a vertical width W2 of two opposite side portions 50a and 50b. With use of this tapered shape, the seam length of the module container 50 in the sewing portion 40 can be reduced.

According to the above-described embodiment having the seam length adjusting portions 60, the seam length of the sewing portion 40 of the module container 50 is reduced, so that the sewing portion 40 of the module container 50 can be made easily breakable when the air bag unfolds. Accordingly, the unfolding direction of the air bag can be made steadier. Each seam length adjusting portion 60 may be obtained by cutting each front end portion 51 of a module container 50 in the form of a chevron as in a sixth embodiment shown in FIG. 7B, for example. Alternatively, part of each front end portion 51 may be notched in the width direction, as in a seventh embodiment shown in FIG. 7C.

According to this invention, the first and second cover elements to which the front end portions 51 of the module container 50 are sewn may be any other cover elements than the seat-back front cover element 25a and the side cover element 25b.

In each of the foregoing embodiments, the air bag module 30 is supposed to be incorporated in the seat back 22 of a passenger seat in a right-hand wheel vehicle. However, this invention may be also applied, with the same effect as aforesaid, to a seat in which an air bag module 30 and a module container 50 similar to the ones according to the foregoing embodiments are incorporated in a side portion that is nearer to the door of the seat back of a driver's seat, for example.

Industrial Applicability

In the air-bagged seat according to this invention, the unfolding direction of the air bag can be regulated by means of the module container, so that the air bag can be unfolded toward a predetermined expected portion to be broken. This air bag can enjoy a stable unfolding direction and display proper unfolding performance. The air-bagged seat of this invention is suited for use in a vehicle such as an automobile.

Additional advantages and modifications will readily occur to those skilled in the art. Therefore, the invention in its broader aspects is not limited to the specific details and representative embodiments

shown and described herein. Accordingly, various modifications may be made without departing from the spirit or scope of the general inventive concept as defined by the appended claims and their equivalents.

C L A I M S

1. In an air-bagged seat comprising an air bag module (30) in a seat back (22), the air-bagged seat characterized in that:

5 a cover member (25) for covering an air bag storage portion (22a) of said seat back (22) is formed by sewing up at least a first cover element (25a) and a second cover element (25b);

10 said air bag module (30) is stored in a belt- or bag-shaped module container (50) having a pair of opposite side portions (50a, 50b), right and left, and a rear end portion (50c); and

15 front end portions (51) of the opposite side portions (50a, 50b) of said module container (50) are sewn together with said first and second cover elements (25a, 25b) in a sewing portion (40) between the cover elements (25a, 25b).

2. An air-bagged seat according to claim 1, wherein said module container (50) is formed having 20 holes (55) through which bolts (35) for fixing said air bag module (30) to a seat back frame (23) are passed individually, and said air bag module (30) and the module container (50) are fixed to the seat back frame (23) with said bolts (35) in the holes (55).

25 3. An air-bagged seat according to claim 1, wherein said module container (50) has a shape such that a bottom portion (50e) and the rear end portion

(50c) between said opposite side portions (50a, 50b) are closed, and that the top portion and the front end portions (51) of said opposite side portions (50a, 50b) can be opened when the air bag inflates.

- 5 4. An air-bagged seat according to claim 1, wherein each said front end portion (51) of said module container (50) is provided with a seam length adjusting portion (60) for adjusting the seam length of the module container (50) sewn to the cover member (25).

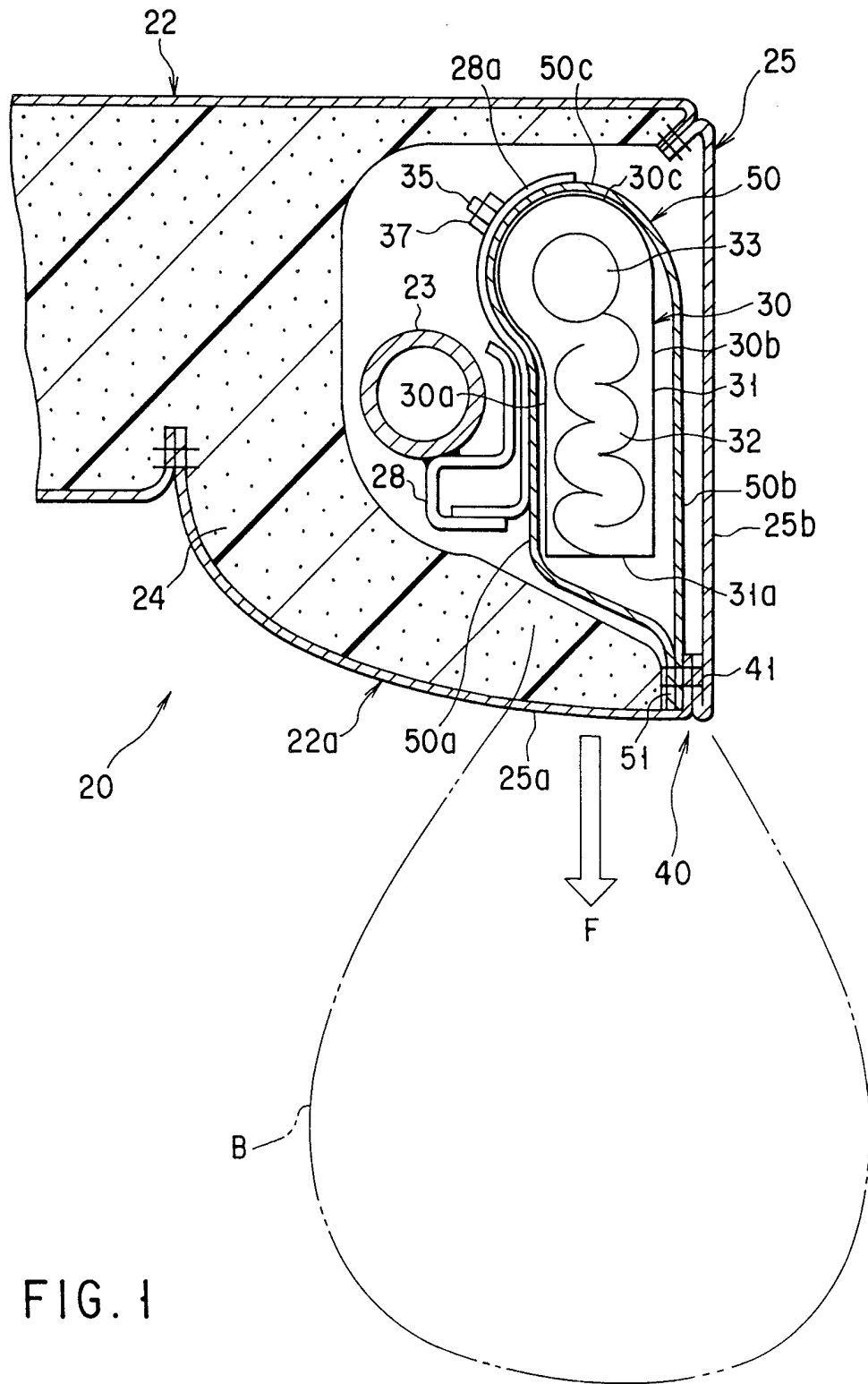

FIG. 1

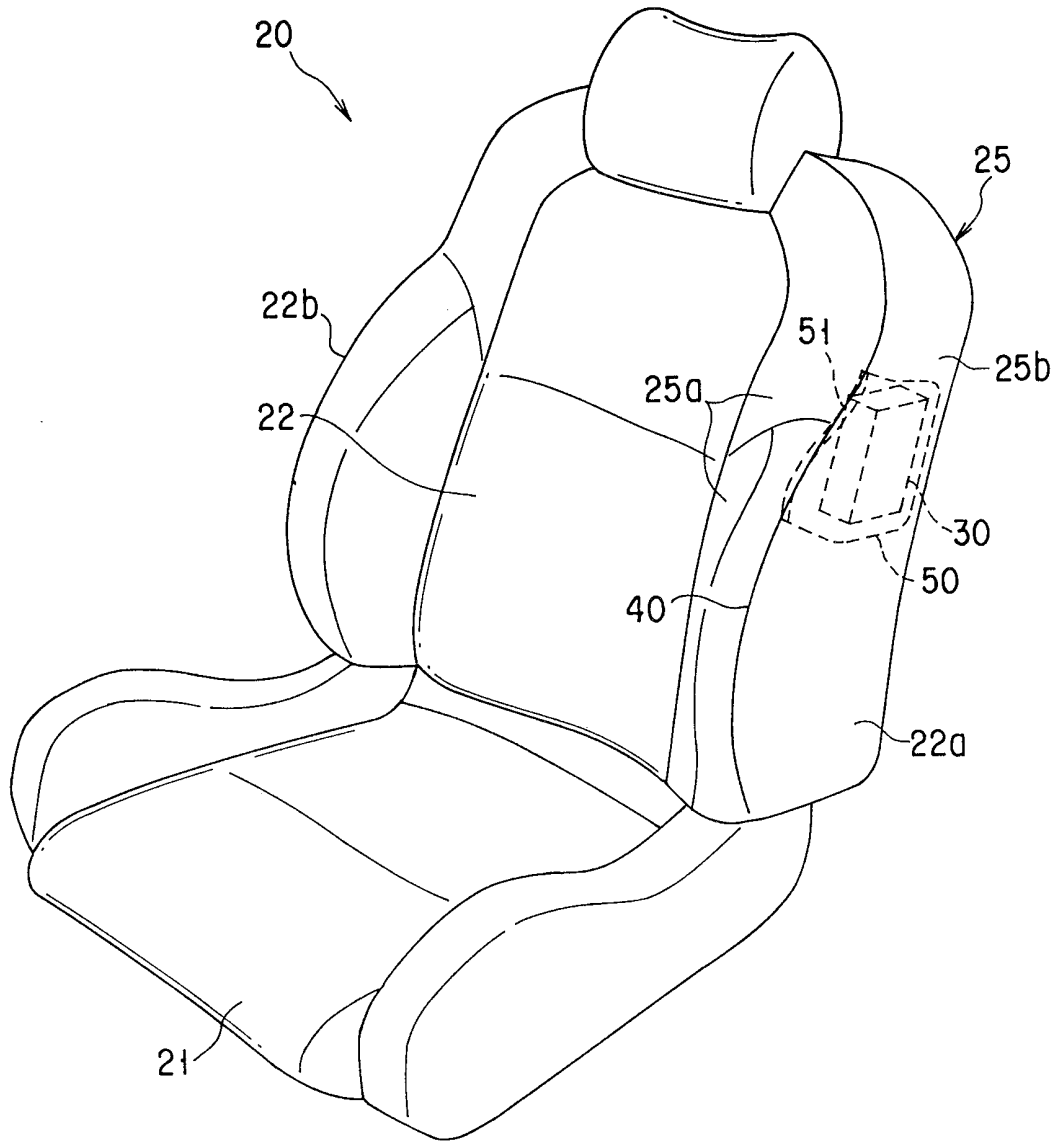

FIG. 2

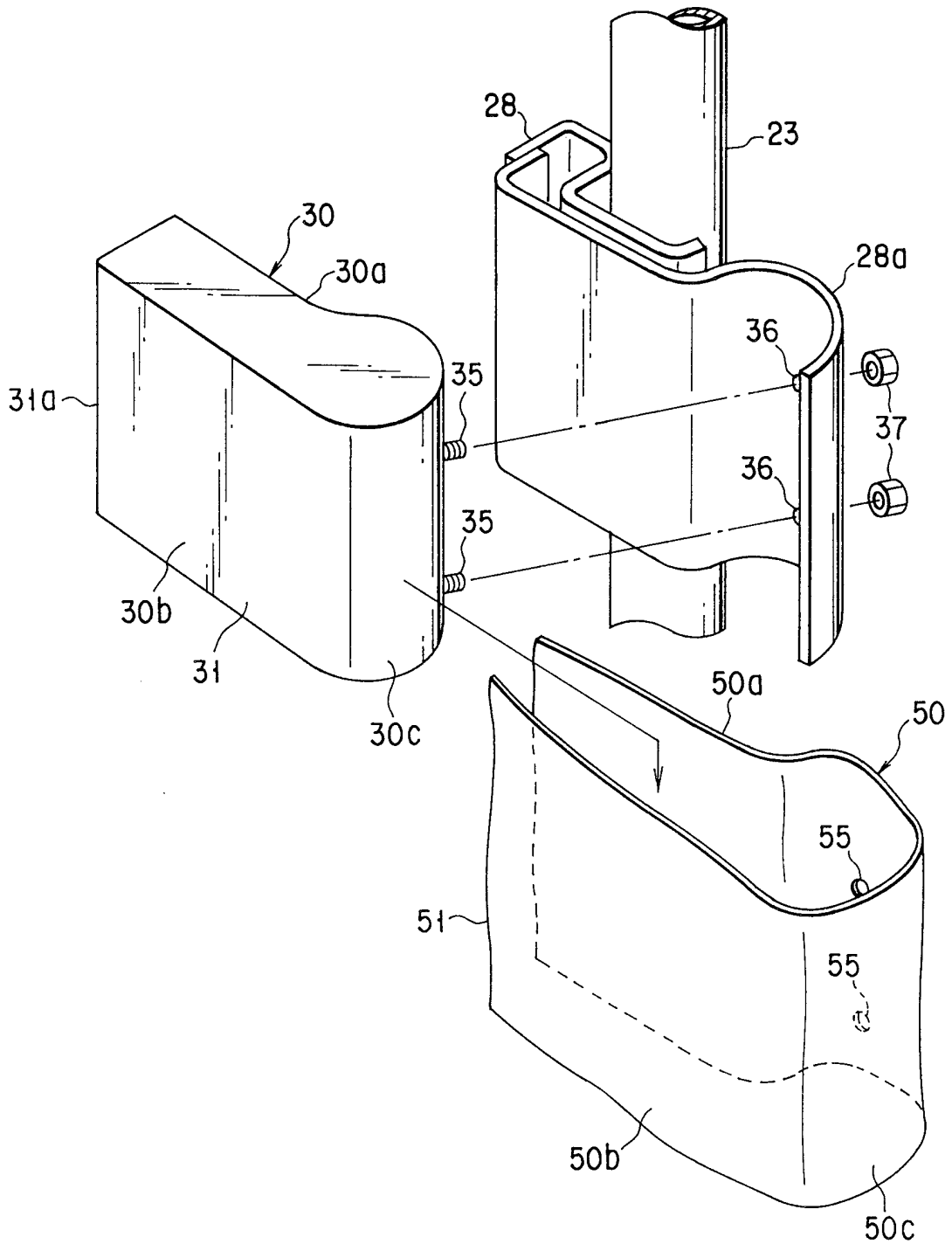

FIG. 3

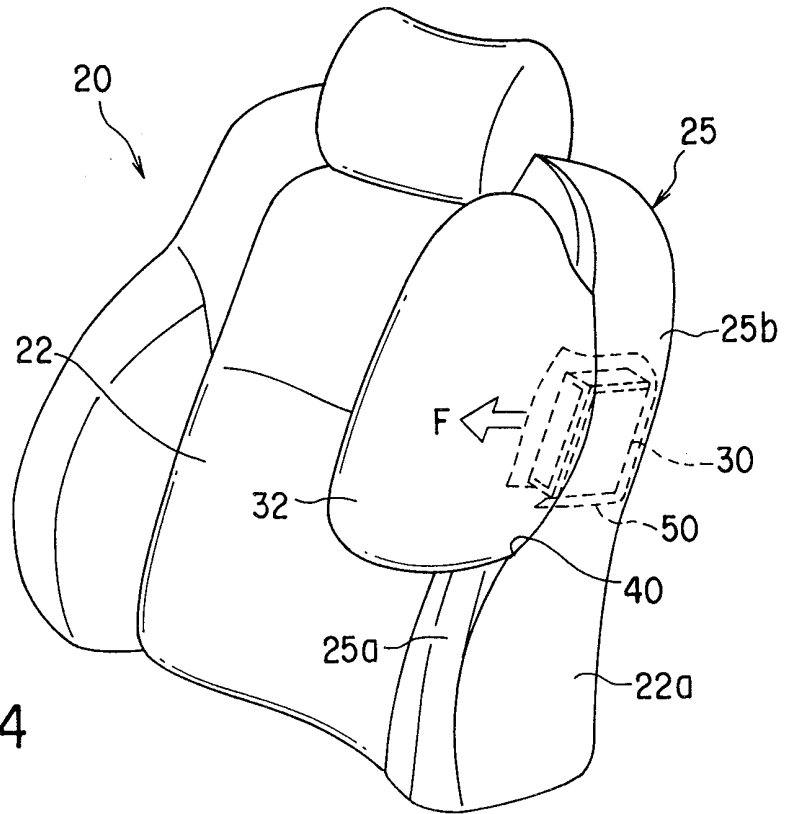

FIG. 4

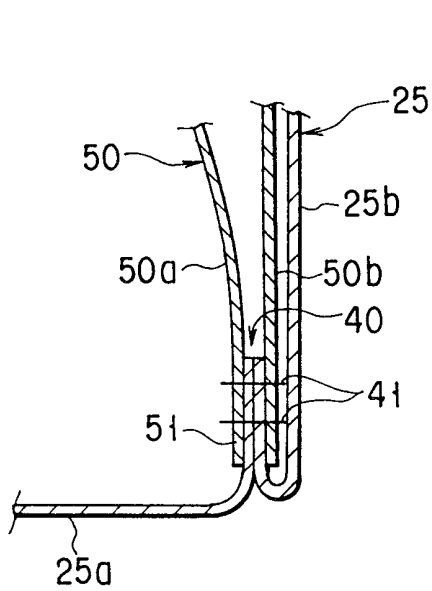

FIG. 5A

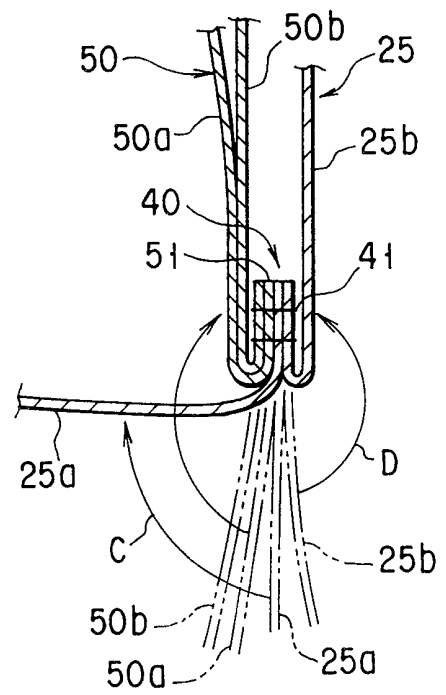

FIG. 5B

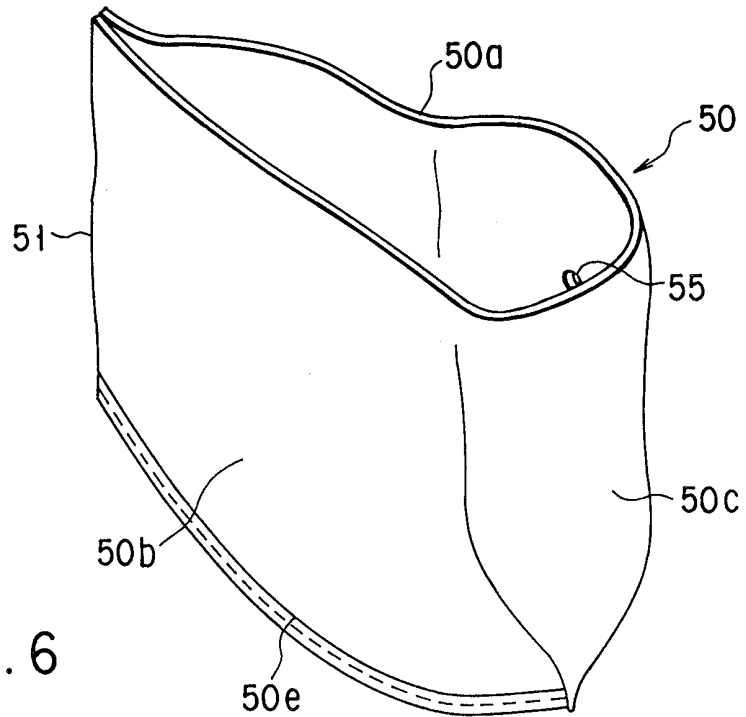

FIG. 6

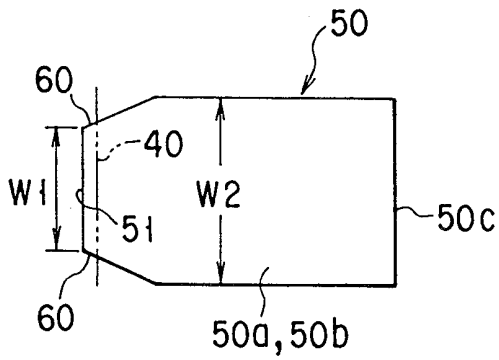

FIG. 7A

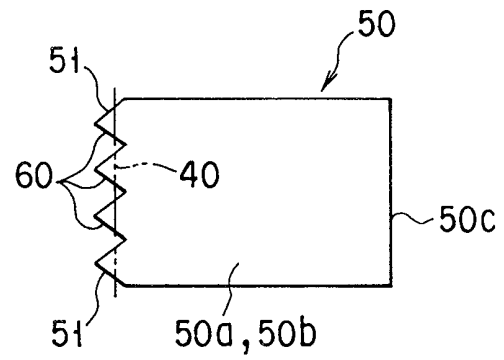

FIG. 7B

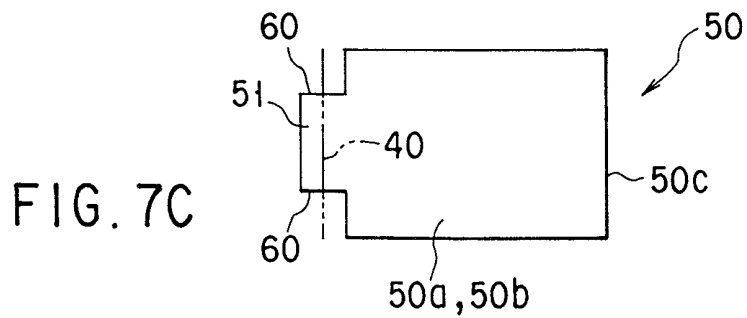

FIG. 7C

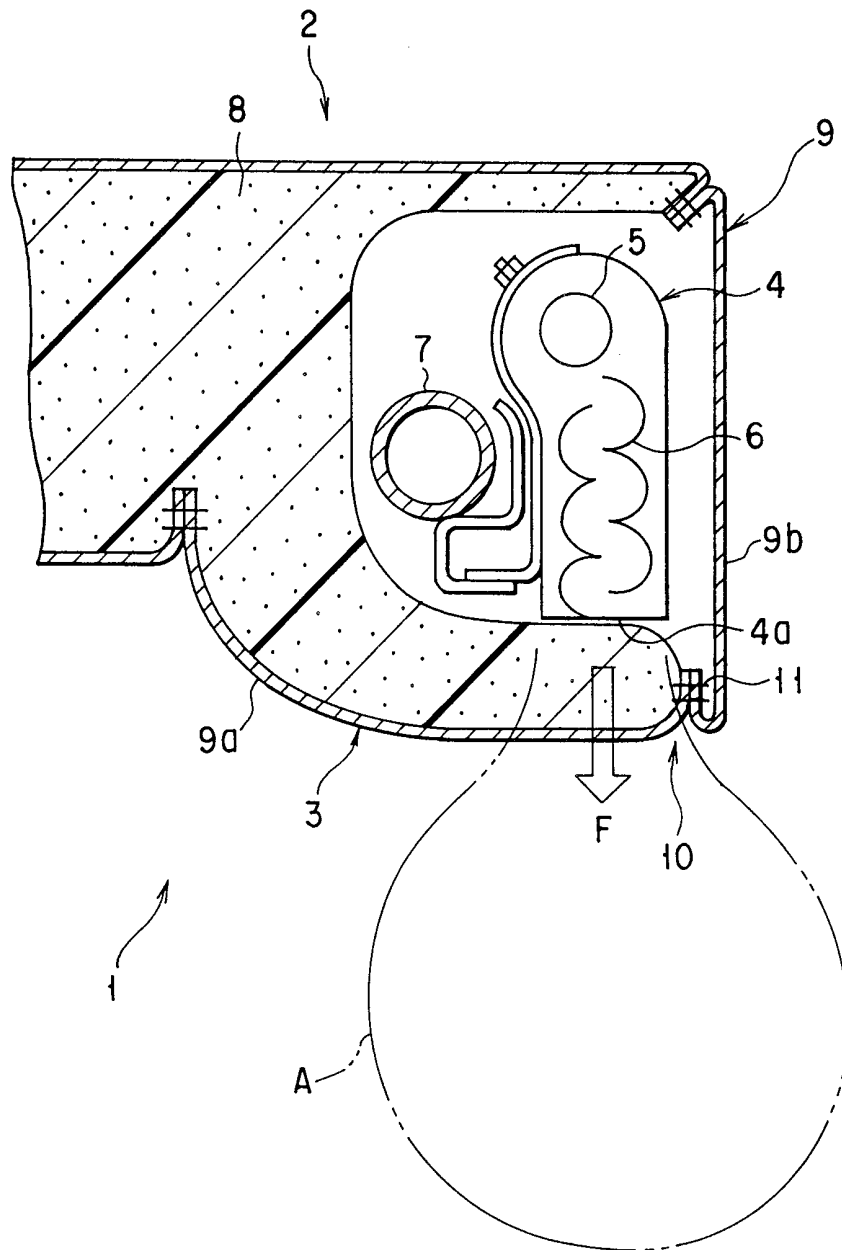

FIG. 8

INTERNATIONAL SEARCH REPORT

Int'l Application No
PCT/JP 99/04121

A. CLASSIFICATION OF SUBJECT MATTER
IPC 7 B60R21/20

According to International Patent Classification (IPC) or to both national classification and IPC

B. FIELDS SEARCHED

Minimum documentation searched (classification system followed by classification symbols)

IPC 7 B60R

Documentation searched other than minimum documentation to the extent that such documents are included in the fields searched

Electronic data base consulted during the international search (name of data base and, where practical, search terms used)

C. DOCUMENTS CONSIDERED TO BE RELEVANT

Category *	Citation of document, with indication, where appropriate, of the relevant passages	Relevant to claim No.
P, X	GB 2 322 603 A (HOOVER UNIVERSAL) 2 September 1998 (1998-09-02) figures 3-3B abstract page 7, line 34 -page 9, line 4 ---	1,2
X	GB 2 293 355 A (ALLIEDSIGNAL DEUTSCHLAND GMBH) 27 March 1996 (1996-03-27) figures 6A,6B abstract	1
A	page 12, line 27 -page 13, line 12 ---	2,3
A	WO 98 12076 A (GUSTIN LEROUGE JOSE ;PATTE DAMIEN (FR); RECH POUR L AUTOMOBILE CE) 26 March 1998 (1998-03-26) figures abstract page 3, line 21 -page 4, line 31 ---	1-4
-/--		

Further documents are listed in the continuation of box C.

Patent family members are listed in annex.

* Special categories of cited documents :

- "A" document defining the general state of the art which is not considered to be of particular relevance
- "E" earlier document but published on or after the international filing date
- "L" document which may throw doubts on priority claim(s) or which is cited to establish the publication date of another citation or other special reason (as specified)
- "O" document referring to an oral disclosure, use, exhibition or other means
- "P" document published prior to the international filing date but later than the priority date claimed

- "T" later document published after the international filing date or priority date and not in conflict with the application but cited to understand the principle or theory underlying the invention
- "X" document of particular relevance; the claimed invention cannot be considered novel or cannot be considered to involve an inventive step when the document is taken alone
- "Y" document of particular relevance; the claimed invention cannot be considered to involve an inventive step when the document is combined with one or more other such documents, such combination being obvious to a person skilled in the art.
- "&" document member of the same patent family

Date of the actual completion of the international search

15 December 1999

Date of mailing of the international search report

12/01/2000

Name and mailing address of the ISA

European Patent Office, P.B. 5818 Patentlaan 2
NL - 2280 HV Rijswijk
Tel. (+31-70) 340-2040, Tx. 31 651 epo nl,
Fax: (+31-70) 340-3016

Authorized officer

D'sylva, C

INTERNATIONAL SEARCH REPORT

International Application No

PCT/JP 99/04121

C.(Continuation) DOCUMENTS CONSIDERED TO BE RELEVANT

Category	Citation of document, with indication, where appropriate, of the relevant passages	Relevant to claim No.
A	US 5 498 030 A (HILL TIMOTHY W ET AL) 12 March 1996 (1996-03-12) figures 7-10 abstract column 5, line 65 -column 7, line 8 ---	1-3
A	US 5 749 597 A (SADERHOLM DAVIN G) 12 May 1998 (1998-05-12) figures abstract column 2, line 15 -column 4, line 34 ---	1-3
A	PATENT ABSTRACTS OF JAPAN vol. 1997, no. 02, 28 February 1997 (1997-02-28) & JP 08 258660 A (IKEDA BUSSAN CO LTD), 8 October 1996 (1996-10-08) abstract -----	1

INTERNATIONAL SEARCH REPORT

Information on patent family members

International Application No
PCT/JP 99/04121

Patent document cited in search report	Publication date	Patent family member(s)	Publication date
GB 2322603 A	02-09-1998	EP 0963310 A WO 9838067 A	15-12-1999 03-09-1998
GB 2293355 A	27-03-1996	DE 777591 T EP 0777591 A WO 9607563 A US 5899489 A	05-03-1998 11-06-1997 14-03-1996 04-05-1999
WO 9812076 A	26-03-1998	FR 2753425 A AU 4306097 A EP 0927115 A	20-03-1998 14-04-1998 07-07-1999
US 5498030 A	12-03-1996	WO 9630233 A	03-10-1996
US 5749597 A	12-05-1998	NONE	
JP 08258660 A	08-10-1996	JP 2848482 B	20-01-1999