

19



Europäisches Patentamt  
European Patent Office  
Office européen des brevets



11 Publication number:

**0 397 372 B1**

12

**EUROPEAN PATENT SPECIFICATION**

- 45 Date of publication of patent specification: **03.08.94** 51 Int. Cl.<sup>5</sup>: **H04Q 3/52, H04Q 3/68, H04Q 11/00**
- 21 Application number: **90304731.4**
- 22 Date of filing: **01.05.90**

64 **Network topology for reduced blocking and photonic system implementation thereof.**

30 Priority: **08.05.89 US 349281**

43 Date of publication of application:  
**14.11.90 Bulletin 90/46**

45 Publication of the grant of the patent:  
**03.08.94 Bulletin 94/31**

64 Designated Contracting States:  
**BE DE ES FR GB IT NL**

56 References cited:  
**EP-A- 0 282 227**

**IEEE TRANSACTIONS ON COMMUNICATIONS**. vol. 35, no. 12, December 1987, **NEW YORK, US**, pages 1357-1365; K.Padmanabhan et al: "Dilated Networks for Photonic Switching"

**PHILIPS JOURNAL OF RESEARCH**. vol. 41, no. 6, 1986, **EINDHOVEN, NL**, pages 507-530; P.J. Severin: "Self-routing Fibre-optic Networks and Switches Using Multi-tailed Receiver/Transmitter Units"

73 Proprietor: **AT&T Corp.**  
**32 Avenue of the Americas**  
**New York, NY 10013-2412(US)**

72 Inventor: **Cloonan, Thomas J.**  
**7625 Bainbridge Drive**  
**Downers Grove, Illinois 60516(US)**  
Inventor: **Hinterlong, Stephen J.**  
**1729 Richard Street**  
**Aurora, Illinois 60505(US)**  
Inventor: **Hinton, Harvard S.**  
**1229 Calico Avenue**  
**Naperville, Illinois 60565(US)**  
Inventor: **Hwang, Frank K.**  
**139 King George Road**  
**Warren, New Jersey 07060(US)**  
Inventor: **Jahns, Jurgen**  
**194 Garden Road**  
**Shrewsbury, New Jersey 07702(US)**  
Inventor: **Jewell, Jack L.**  
**12 Timberline Drive**  
**Bridgewater, New Jersey 08807(US)**  
Inventor: **Lentine, Anthony L.**  
**36W835 Oak Road**  
**St. Charles, Illinois 60175(US)**

Note: Within nine months from the publication of the mention of the grant of the European patent, any person may give notice to the European Patent Office of opposition to the European patent granted. Notice of opposition shall be filed in a written reasoned statement. It shall not be deemed to have been filed until the opposition fee has been paid (Art. 99(1) European patent convention).

**EP 0 397 372 B1**

IEEE TRANSACTIONS ON COMPUTERS, vol. 37, no. 4, April 1988, NEW YORK, US, pages 458-462; N.Tzeng et al: "Realizing Fault-Tolerant Interconnection Networks via Chaining"

IEEE JOURNAL ON SELECTED AREAS IN COMMUNICATION, vol. 6, no. 7, August 1988, NEW YORK, US, pages 1209-1226; H. Scott Hinton: "Architctural Considerations of Photonic Switching Networks"

SYSTEMS, COMPUTERS, CONTROLS, vol. 11, no. 2, 1980, WASHINGTON, US, pages 64-71; K. Shirata et al: "The Fast Walsh-Hadamard Transform and Processors by Using New Permutation Networks"

Inventor: McCormick, Frederick B., Jr.  
5905 Meadow Drive  
Lisle, Illinois 60532(US)

Inventor: Miller, David A. B.  
64 Hance Road  
Fairhaven, New Jersey 07704(US)

Inventor: Murdocca, Miles J.  
R.D. Nr. 4, Box 380  
Jackson, New Jersey 08527(US)

Inventor: Prlse, Michael E.  
98 W. Highland Avenue  
Atlantic Highlands, New Jersey 07716(US)

Inventor: Richards, Gaylord W.  
7 South 560 Green Acres Drive  
Naperville, Illinois 60540(US)

⑦ Representative: Buckley, Christopher Simon  
Thirsk et al  
AT&T (UK) LTD.,  
AT&T Intellectual Property Division,  
5 Morningside Road  
Woodford Green, Essex IG8 0TU (GB)

**Description****Technical Field**

5 This invention relates to systems for information processing or switching.

**Background and Problem**

10 Communication networks are generally designed as point-to-point networks to interconnect, upon request, selected pairs of terminals from a large plurality of terminals connected to the network. The simplest network capable of connecting  $N$  network inlets to  $N$  network outlets is an  $N \times N$  crossbar array of switching elements or crosspoints. Although such an array is non-blocking in that any idle inlet is always connectable to any idle outlet regardless of other array interconnections, the crossbar array is not a practical network in many applications due to the prohibitive cost of the large number of array crosspoints.

15 One known non-blocking network having significantly fewer crosspoints than a crossbar array is disclosed in an article by C. Clos, "A Study of Non-Blocking Switching Networks," Bell System Technical Journal, March 1953, pages 406-424. The network, referred to as the three-stage Clos network, has  $N$  inlets and  $M$  outlets and comprises  $N/n$  rectangular  $n \times r$  first stage switches,  $r$  rectangular  $N/n \times M/m$  second stage switches and  $M/m$  rectangular  $r \times m$  third stage switches. There is exactly one link connecting each  
 20 first stage switch to each second stage switch and one link connecting each second stage switch to each third stage switch. A three-stage Clos network where the number,  $r$ , of second stage switches is given by  $r = n + m - 1$ , is a non-blocking point-to-point network. This is true since a given first stage switch input terminal is always connectable to a given third stage switch output terminal via a second stage switch that is connected to none of the other  $n - 1$  input terminals of the given first stage switch and none of the other  
 25  $m - 1$  output terminals of the given third stage switch. A five-stage Clos network can be constructed by replacing each second stage switch with a three-stage Clos network. More generally, an  $S + 2$  stage Clos network can be recursively constructed from an  $S$  stage Clos network by replacing each switch in a given stage with a three-stage Clos network. However, Clos networks are difficult to implement in, for example, the photonics domain because the switching elements are typically quite large, and there are different  
 30 numbers of links between stages, with the number of links increasing geometrically toward the center of the network. Efficient photonic network implementations typically have small, non-complex switching elements, e.g.,  $2 \times 2$  nodes, and are relatively space-invariant from stage to stage. The interest in photonic networks is mainly stimulated by their potential to implement massively parallel architectures. This holds especially true for free space systems where three-dimensional space is the communications medium and where imaging setups use bulk optical elements such as lenses, mirrors, and beam splitters to interconnect two-  
 35 dimensional arrays of optical logic devices.

Another known network architecture is the so-called perfect shuffle. A perfect shuffle network of  $2 \times 2$  nodes is a cost-effective interconnection network, for example, in large-scale parallel and distributed supercomputer systems, because it provides network connectivity from any of  $N$  network inlets to any of  $N$   
 40 network outlets in only  $\log_2 N$  stages. The inter-stage interconnection pattern assigns links consecutively to nodes in the next stage in a manner analogous to shuffling a deck of playing cards. There are a number of other known networks, such as the banyan and the crossover, which are topologically equivalent to the perfect shuffle although they each have their own specific interconnection pattern. For each of these networks, the number of inter-stage links between any pair of successive stages is equal to  $N$ , the number  
 45 of network inlets. Photonic implementations of such networks using free-space optical interconnects are disclosed in U. S. patent application 296,284 of K. Brenner et al., filed January 11, 1989, "Optical Shuffle Arrangement" and U. S. patent application 219,623 of J. Jahns et al., filed July 15, 1988, "Optical Crossover Network", both applications being assigned to the same assignee as the present invention. Networks of this type are, however, not fault-tolerant and have high blocking. The problem with the topology is that in a  
 50 network having  $\log_2 N$  stages, there is only one path from a given network inlet to a given network outlet. Thus, if there is a fault on that path or some part of the path is busy, no communication is possible. An article of G. B. Adams et al., "The Extra Stage Cube: A Fault-Tolerant Interconnection Network for Supersystems", IEEE Transactions on Computers, Vol. C-31, No. 5, May 1982, discloses the addition of an extra stage to the network thus providing one additional path between any inlet and any outlet. Although this  
 55 makes the network substantially more reliable, it still has an unacceptably high blocking probability. Furthermore, the simple addition of extra stages will never result in a point-to-point, strictly nonblocking network or even one with a blocking probability that is acceptably low in most high-traffic network applications.

EP-A-0 282 227 discloses an optical switching system which comprises a perfect shuffle equivalent network. There is only one path between a given system inlet and a given system outlet. The network is a self-routing network which performs a sort function based on addresses transmitted prior to the information to be switched. Accordingly, the nodes are relatively complex and include the electronics required to perform the sort function. The nodes have two optical states--the exchange state and the bypass state--and convey two optical signals in each state. Because there are two signals within a node, the likelihood of encountering crosstalk problems is increased as compared with a capacity one node. The complexity of the system is further increased by using microoptics, specifically microlenses rather than all bulk optics.

IEEE TRANSACTIONS ON COMMUNICATIONS, vol. 35, No. 12, December 1987, New York, US; pages 1357-1365; K.PADMANABHAN et al. discloses an NxN dilated Omega network. Exclusive of the dilation (the expansion/concentration), the system has only two switching stages with one stage of links therebetween. The system uses lithium niobate couplers and is dilated to reduce crosstalk by reducing the probability that two active signals will pass through one node. There is only one path between the system inlets and the outputs of the last switching node stage.

In view of the foregoing, a recognized problem in the art is the lack of a low-blocking or non-blocking network that is efficiently implementable in the photonics domain.

According to this invention there is provided a system as claimed in claim 1.

The invention will now be described with reference to the accompanying drawings, in which:

FIG. 1 is a diagram of an exemplary photonic system comprising expansion, a perfect shuffle equivalent network, and concentration;

FIG. 2 is a diagram of an illustrative network topology for a system comprising expansion, a perfect shuffle equivalent network, and concentration;

FIGS. 3, 4, and 5 are diagrams of the network topology of FIG. 2 but with different expansion and concentration implementations;

FIGS. 6, 7, and 8 are diagrams of a full capacity node, a capacity one node with selectivity, and a capacity one node without selectivity, respectively, for use in the system of FIG. 2;

FIG. 9 is a diagram of a network topology similar to that of FIG. 2 but without concentration;

FIG. 10 is a diagram of a network topology similar to that of FIG. 2 but without expansion;

FIG. 11 is a diagram of a single stage strictly nonblocking network;

FIG. 12 is a diagram of a strictly nonblocking three stage Clos network;

FIG. 13 is a diagram of a general strictly nonblocking three stage Clos network;

FIG. 14 is a diagram of a strictly nonblocking five stage Clos network;

FIG. 15 is a diagram of a multistage interconnection network (MIN);

FIG. 16 is a diagram of a particular type of MIN, referred to herein as an extended generalized shuffle (EGS) network;

FIGS. 17 and 18 are diagrams of an example EGS network;

FIG. 19 is a diagram illustrating a channel graph  $L(x,y)$  from inlet  $x$  to outlet  $y$  of the network of FIGS. 17 and 18;

FIG. 20 is a diagram showing a single intersecting call in addition to the channel graph  $L(x,y)$  of FIG. 19;

FIGS. 21 and 23 are diagrams of the network of FIG. 16 that are used in deriving nonblocking criteria for the network;

FIG. 22 is a diagram of the network of FIG. 18 that is used in describing a network property referred to herein as the forward-backward invariance property (FBIP);

FIG. 24 is a diagram of an example nonblocking EGS network;

FIG. 25 is a diagram of a particular perfect shuffle equivalent network--the crossover (or half crossover) network;

FIG. 26 is a diagram of an EGS network representing an important special case of perfect shuffle equivalent networks;

FIG. 27 is a path hunt processing flow chart used to effect the path hunt function in an EGS network of FIG. 16 with full capacity nodes;

FIG. 28 is a path hunt processing flow chart used to effect the path hunt function in an EGS network of FIG. 16 with capacity one nodes;

FIG. 29 is a diagram of an exemplary shuffle network used in explaining the relationship of the switches and links of a shuffle network to the inlet, path and outlet numbers;

FIG. 30 is a diagram illustrating the concatenation of binary representations of inlet, path, and outlet numbers for the network of FIG. 29 to form a single binary number;

FIG. 31 is a diagram illustrating the determination of switches, links, inputs and outputs for the network of FIG. 29 from a single binary number;

FIG. 32 is a schematic illustration of the transformations between various stages of two isomorphic network types--crossover networks and shuffle networks--where the transformations are specified herein in Tables 1-3;

FIGS. 34-36, when arranged in accordance with FIG. 33, comprise a diagram of a 16x16 two-dimensional crossover network using one-dimensional arrays of nodes;

FIG. 37 is a diagram illustrating the relative sizes of the 16x16 crossover network of FIGS. 34-36, a 128x128 crossover network, and a 512x512 crossover network of FIG. 38;

FIG. 38 is a diagram of a 512x512 crossover network and a corresponding crossover network controller;

FIG. 39 is a connection request processing flow chart for the crossover network controller of FIG. 38;

FIG. 40 is a disconnect request processing flow chart for the crossover network controller of FIG. 38;

FIGS. 42-44, when arranged in accordance with FIG. 41, comprise a diagram of a hardware logic circuit implementation of the crossover network controller of FIG. 38;

FIG. 45 is a diagram of an alternative network controller embodiment that has duplicate copies of the network controller memories;

FIG. 46 is a diagram of a disjoint path check unit of the controller of FIGS. 42-44;

FIG. 47 is a timing diagram illustrating overlap path hunt processing by the controller of FIGS. 42-44;

FIG. 48 is a timing diagram illustrating overlap path hunt processing by the alternative controller of FIG. 45;

FIG. 49 is a diagram of a network having a first stage of  $1 \times 2^n$  elements, a last stage of  $2^n \times 1$  elements, and for which the disjoint path check unit of FIG. 46 is applicable;

FIG. 50 is a diagram of a crossover to shuffle mapping unit of the controller of FIGS. 42-44;

FIG. 51 is a diagram of an idle path select unit of the controller of FIGS. 42-44;

FIGS. 52 and 53 are diagrams of a two-dimensional crossover network implementation and a two-dimensional shuffle network implementation, respectively;

FIGS. 55-57, when arranged in accordance with FIG. 54, comprise a diagram of a 16x16, three-dimensional crossover network that is topologically equivalent to the two-dimensional crossover network of FIGS. 34-36;

FIG. 58 is a diagram of an array of symmetric self electro-optic effect devices (S-SEEDs) used in the network of FIGS. 55-57;

FIG. 59 is a diagram of a crossover network having two-input, two-output switching nodes within the fanout (expansion) and fanin (concentration) sections as well as within the switching section;

FIG. 60 is a diagram of an electronic tri-state buffer implementation of a switching node referred to herein as a 2-module;

FIG. 61 is a truth table defining the operation of the tri-state buffer of FIG. 60;

FIG. 62 is a diagram of an electronic inverting tri-state buffer implementation of a 2-module;

FIG. 63 is a diagram of an optical 2-module implementation using a device referred to herein as an M-SEED;

FIG. 64 is a truth table defining the operation of the M-SEED implementation of FIG. 63;

FIG. 65 is a diagram of an electronic OR/AND implementation of a 2-module;

FIG. 66 is a truth table defining the operation of the electronic OR/AND implementation of FIG. 65;

FIG. 67 is a diagram of an electronic NOR/OR implementation of a 2-module;

FIG. 68 is a diagram of an optical NOR/OR S-SEED implementation of a 2-module;

FIG. 69 is a truth table defining the operation of the optical NOR/OR S-SEED implementation of FIG. 68;

FIG. 70 is a diagram of an electronic NAND/AND implementation of a 2-module;

FIG. 71 is a diagram of an optical NAND/AND S-SEED implementation of a 2-module;

FIG. 72 is a truth table defining the operation of the optical NAND/AND S-SEED implementation of FIG. 71;

FIG. 73 is a diagram of a timing circuit used to drive the laser diodes for a single network stage;

FIG. 74 is a diagram of a timing circuit used to drive the laser diodes for three successive network stages;

FIG. 75 is a timing diagram associated with the timing circuit of FIG. 74;

FIG. 76 is a diagram illustrating horizontal connections in the three-dimensional crossover network of FIGS. 55-57;

FIG. 77 is a diagram illustrating vertical connections in the three-dimensional crossover network of FIGS. 55-57;

FIG. 78 is a diagram of a network having nine node stages and having a single path identified by bold links;

FIG. 79 is a diagram showing the line of linked 2-modules of the single path of FIG. 78 and associated disabled 2-modules;

FIG. 80 is a diagram illustrating the relationship of the 2-modules of successive stages of the network of FIG. 78;

FIG. 81 is a functional block diagram of a portion of the photonic system of FIG. 1;

FIG. 82 is a diagram of an implementation of an optical crossover interconnect in the photonic system of FIG. 1;

FIG. 83 is a diagram illustrating the connection formed by the optical crossover interconnect of FIG. 82;

FIG. 84 is a diagram of a prismatic mirror array which may replace a prismatic mirror in the optical crossover interconnect of FIG. 82 to vary the width of the cross in a crossover network;

FIG. 85 is a diagram of an optical arrangement used for generating the preset and power beam arrays in the photonic system of FIG. 1;

FIG. 86 is a diagram of an optical arrangement including a spatial light modulator used for generating the disable beam arrays in the photonic system of FIG. 1;

FIGS. 87, 88, and 90 are diagrams of sub-units of a beam combination unit included in the photonic system of FIG. 1;

FIG. 89 is a plot of typical transmission curves for a polarization beam splitter designed for 850-nanometer operation;

FIG. 91 is a diagram illustrating the transmission and reflection of spots by patterned mirror reflectors included in the beam combination sub-unit of FIG. 90;

FIG. 92 is a diagram illustrating the receipt and reflection of spots by the S-SEED array of FIG. 58;

FIG. 93 is a diagram of an optical hardware module included in the photonic system of FIG. 1 and comprising the optical crossover interconnect of FIG. 82, the beam combination sub-units of FIGS. 87, 88 and 90, power and preset beam array generators of the type shown in FIG. 85, a disable beam array generator of the type shown in FIG. 86 and the S-SEED array of FIG. 58;

FIGS. 95 and 96, when arranged in accordance with FIG. 94, comprise a diagram of two cascaded optical hardware modules included in the photonic system of FIG. 1;

FIG. 97 is a diagram of a data input unit included in the photonic system of FIG. 1; and

FIGS. 98, 99 and 100 are diagrams of alternative wavelength-dependent beam combination apparatus.

In an exemplary system a perfect shuffle equivalent network, defined herein and having a plurality of node stages successively interconnected by link stages, is advantageously combined with expansion before the node stages and/or concentration after the node stages in a manner allowing the design of a system with arbitrarily low or zero blocking probability. An illustrative photonic system implementation (FIG. 1) uses free space optical apparatus to effect a low loss, crossover interconnection of two-dimensional arrays of switching nodes comprising, for example, the symmetric self electro-optic effect devices (S-SEEDs) disclosed in U.S. Patent 4,754,132 issued to H.S.Hinton et al, on June 28, 1988. Several low loss beam combination techniques are used to direct multiple arrays of beams to an S-SEED array, and to redirect a reflected output beam array to a subsequent node stage.

A system embodying the invention has N inlets and M outlets and includes stages of nodes and stages of links collectively comprising a perfect shuffle equivalent network. Each node has one or more inputs and one or more outputs, where the sum of the number of inputs and the number of outputs is greater than two. The number of node stages is at least four. In addition, to the perfect shuffle equivalent network, the system includes means for expanding the N inlets to more than N inputs of the first node stage and means for concentrating more than M outputs of the last node stage to the M outlets. The system has at least two paths between each of the N inlets and each output of the last node stage.

In the illustrative photonic system (FIG 1), both the perfect shuffle equivalent network and the expansion and concentration are implemented using free-space optics. Each of the N=16 system inlets is connected to F=4 inputs of the first node stage of the perfect shuffle equivalent network in a perfect shuffle sustaining pattern defined herein. Each of the node stages of the perfect shuffle equivalent network has 32 nodes each having two inputs and two outputs (the three-dimensional network topology for the system is shown in FIGS.55-57). The expansion portion of the system comprises  $\log_2 F=2$  stages of nodes each having one input and two outputs. The concentration portion of the system, comprising  $\log_2 F=2$  stages of nodes each having two inputs and one output, connected F=4 outputs of the last node stage of the perfect shuffle equivalent network to each of the M=16 system outlets, also in a perfect shuffle sustaining pattern.

In the illustrative system, the nodes are reduced-functionality switching nodes referred to herein as 2-modules. A 2-module has no input selectivity and no output selectivity but instead is responsive to a control signal for broadcasting an output signal to two nodes of the succeeding node stage, where the output signal is a logical combination of signals receivable from two of the nodes of the preceding node stage. The

functionality of a switching network is achieved by controlling which nodes are enabled rather than by specifying connections of particular node inputs and outputs to be effected by the nodes. The nodes of the system are controlled such that a given 2-module receives at most one active signal from the preceding stage at any time. A 2-module is implemented using an S-SEED.

5 A plurality of beam arrays are incident on each S-SEED array. An array of control beams, also referred to herein as disable beams, is used to control the optical connectivity of corresponding S-SEEDs. The disable beam array is generated from a uniform array of beams using a spatial light modulator which is responsive to electrical control signals for selectively transmitting those beams of the uniform array that correspond to S-SEEDs to be disabled. The electrical control signals are generated in response to requests  
10 for connections through the system. An array of preset beams is used to establish the optical state of corresponding S-SEEDs prior to the communication of optical information therethrough. Each S-SEED receives information for communication through the system from one of two S-SEEDs of the preceding stage; accordingly, two arrays of information beams are received by an S-SEED array. An S-SEED changes its optical state in response to the logic value of an incident information beam. An array of power beams is  
15 then used to read the optical state of corresponding S-SEEDs. S-SEEDs reflect or absorb the power beams depending on their optical state. The reflected power beams are directed as output beams to the next stage. A beam splitter splits each output beam into two beams each for transmission to one S-SEED of the next node stage. The low loss combination and redirection of the plurality of beam arrays are effected by a beam combination unit (FIG. 93) using polarization-dependent, spatial-position-dependent, and wavelength-  
20 dependent optical elements. In the illustrative photonic system, the information, power and output beam arrays are at one wavelength (850-nanometers) while the disable and preset beam arrays are at another wavelength (780-nanometers).

The topology of the invention has much broader application than the specific example of the illustrative photonic system. Part or all of the expansion, perfect shuffle equivalent network, and concentration of the  
25 system may be implemented, for example, in the electrical domain. The perfect shuffle equivalent network may include node stages having different numbers of nodes and different numbers of node inputs and node outputs. The nodes themselves may be full capacity nodes that have the capability to simultaneously and selectively interconnect multiple node inputs and multiple node outputs, or capacity one nodes which carry at most one information signal. Rather than implementing the expansion and concentration using additional  
30 stages of nodes as in the illustrative photonic system, other fanout and fanin arrangements may be used. Criteria are disclosed herein for designing a system with an arbitrary blocking probability, e.g., less than 0.5, or a system that is a non-blocking network for point-to-point connections. The design flexibility stems in great measure from the fact that the non-blocking criteria are global rather than being dependent on relationships between the number of node inlets and the number of node outlets in specific node stages.

35 Alternatively, a system embodying the invention has N inlets and M outlets and includes stages of nodes and stages of links. Each node has one or more inputs and one or more outputs, where the sum of the number of inputs and outputs is greater than two. The number of node stages is at least four. Each link stage connects the outputs of one of the node stages to the inputs of the successive one of said node stages in accordance with a crossover interconnection pattern having  $2^r$  partitions, where r is an integer  
40 which varies with link stage. The system further includes means for expanding the N inlets to more than N inputs of the first node stage and means for concentrating more than M outputs of the last node stage to the M outlets. The system has at least two paths between each of the N inlets and each output of the last node stage.

One specific illustrative embodiment of the invention is used in the exemplary photonic system 10 (FIG.  
45 1) which implements a 16 x 16 circuit-switched, space division switching network. Sixteen optical input signals are received on the fibers of a 2 x 8 fiber cable array 21. Each optical input signal may be circuit-switched by photonic system 10 for transmission on one fiber of a 2 x 8 fiber cable array 22 as an optical output signal. Photonic system 10 includes a lens 80, a data input unit 40, eight optical hardware modules 50 through 57, and a lens 70. It is important to note that photonic system 10 processes arrays of beams in  
50 parallel and that the optical transmissions represented by single beams in FIG. 1 are beam arrays of rectangular cross-section. The optical connections effected by data input unit 40 and optical hardware modules 56 and 57 are fixed. A network controller 60, which may be implemented using a single software-controlled processor or using a hardware logic circuit arrangement, establishes and disconnects paths through photonic system 10 via stage controllers 30 through 35 corresponding to optical hardware modules  
55 50 through 55.

The network topology implemented by photonic system 10 comprises expansion, a perfect shuffle equivalent network, and concentration. The topology is based on a three-dimensional crossover network 2110 (FIGS. 55-57) having nine node stages N0 through N8 and eight link stages L0 through L7. Each node

stage, for example, stage N2, comprises 32 nodes numbered 0 through 31. In photonic system 10, a 4 x 8 array 500 (FIGS. 1 and 58) of symmetric self electro-optic effect devices (S-SEEDs) corresponds to one node stage of network 2110. The S-SEEDs, which selectively reflect light depending on their optical state, are the switching nodes of photonic system 10. Each of the optical hardware modules 50 through 57 includes optical apparatus to effect interconnections corresponding to one of the link stages L0 through L7 of network 2110 (FIGS. 55-57) and to effect combination of information (signal), control (preset and disable), and power beam arrays to be focused onto one of the S-SEED arrays 500. For example, optical hardware module 51, shown in more detail in FIG. 93, includes an optical crossover interconnect 100 corresponding to link stage L1 of network 2110, and a beam combination unit 200 which, in addition to combining beam arrays for transmission to S-SEED array 500, redirects an output beam array, reflected from S-SEED array 500, for transmission to the next optical hardware module 52. Communication paths are established through photonic system 10 using spatial light modulators, e.g., 409, which control the generation of arrays of disable beams corresponding to individual S-SEEDs to be disabled.

Note that link stages L0, L1, L5, and L6 of network 2110 (FIGS. 55-57) effect horizontal connections and that link stages L2, L3, L4, and L7 effect vertical connections. Also note that the number of partitions or crosses varies from stage to stage. These variations are implemented in photonic system 10 by variations among the optical hardware modules 50 through 57 as described herein.

### Detailed Description

The description which follows is arranged in four parts. First, a reduced blocking network topology upon which photonic system 10 is based is described. Second, network control arrangements are described for rapidly finding paths and establishing communications through such reduced blocking networks. Third, photonic system 10, including the underlying three-dimensional crossover network 2110 and a reduced-functionality switching node, referred to herein as a 2-module, is described in detail. Finally, the free-space optical arrangements used to implement photonic system 10, including an optical apparatus for combining beams of different wavelengths, are described.

### Network Topology

FIG. 2 is a diagram of a system 1600 comprising an expansion (fanout) section 1610, a perfect shuffle equivalent network 1620, and a concentration (fanin) section 1630. System 1600 has N = 4 inlets and M = 4 outlets. Perfect shuffle equivalent network 1620 has four node stages 1621-0, 1621-1, 1621-2 and 1621-3 comprising 2x2 nodes, and three link stages 1622-0, 1622-1 and 1622-2 each effecting the same perfect shuffle interconnection of successive node stages. Expansion section 1610 expands the N = 4 inlets to 16 (more than N) inputs of the first node stage 1621-0. Concentration section 1630 concentrates 16 (more than M) outputs of the last node stage 1621-3 to the M = 4 outlets. System 1600 has more than two paths between each of the N inlets and each of the M outlets. Individual nodes of the node stages 1621-0, 1621-1, 1621-2 and 1621-3 are controlled by corresponding stage controllers 1640, 1641, 1642, 1643 in response to instructions from a shuffle network controller 1650.

Three alternative implementations for the expansion section 1610 and concentration section 1630 are shown in FIGS. 3, 4 and 5. In expansion section 1710 (FIG. 3), each of the N = 4 inlets is directly connected to four of the inputs of node stage 1621-0. In concentration section 1730, four outputs of node stage 1621-3 are directly connected to each of the M = 4 outlets. Expansion section 1810 (FIG. 4) has a single stage 1811 of 1x4 nodes and concentration section 1830 has a single stage 1831 of 4x1 nodes. Expansion section 1910 (FIG. 5) has two stages 1911 and 1912 of 1x2 nodes and concentration section 1930 has two stages 1931 and 1932 of 2x1 nodes. Each of the expansion sections 1710, 1810, 1910 connects each of the N inlets to multiple inputs of node stage 1621-0 in a perfect shuffle sustaining pattern as defined herein. Each of the concentration sections 1730, 1830, 1930 connects multiple outputs of node stage 1621-3 to each of the M outlets in a perfect shuffle sustaining pattern as defined herein.

Three alternative 2x2 switching nodes 1510, 1520, and 1530 for use in system 1600 are shown in FIGS. 6, 7 and 8. A node with n inputs and m outputs is said to be a full capacity node if it is able to convey  $\min\{n,m\}$  signals at the same time. A node is said to be a capacity one node if it is able to convey only one signal at a time. A capacity one node may have selectivity of either inputs or outputs or may have no selectivity.

Node 1510 (FIG. 6), a full capacity node, comprises two selectors 1511 and 1512. Selector 1511 connects either of the node inputs I1 and I2 to node output O1 in response to a selection signal S1. Selector 1512 connects either of the node inputs I1 and I2 to node output O2 in response to a selection

signal S2.

Node 1520 (FIG. 7), a capacity one node with input selectivity, comprises two AND-gates 1521 and 1522, and an OR-gate 1523. AND-gate 1521 transmits a signal from input I1, via OR-gate 1523, to both outputs O1 and O2 in response to a selection signal S1. AND-gate 1522 transmits a signal from input I2, via OR-gate 1523, to both outputs O1 and O2 in response to a selection signal S2. Only one of the selection signals S1 and S2 is a logic one at any time.

Node 1530 (FIG. 8), a capacity one node without selectivity, comprises an OR-gate 1531 and an AND-gate 1532. When a control signal C is a logic one, AND-gate 1532 transmits the logic union of the signals at the inputs I1 and I2, to both outputs O1 and O2. When the control signal C is a logic zero, AND-gate 1532 transmits a logic zero to both outputs O1 and O2. Only one of the inputs I1 and I2 receives an active signal at any time.

Node 1530 represents a special case of a more general switching node referred to herein as an nxm-module. An nxm-module, which has n inputs and m outputs, either routes the logical union of the signals at the n inputs to all of the m outputs, or routes none of the signals at the n inputs to any of the m outputs. If a network of nxm-modules is controlled such that at most one input of an nxm-module has an active signal, the nxm-module functions to either route the signal to all of the m outputs or to leave the m outputs idle. Node 1530 is a 2x2-module, also referred to herein as a 2-module.

When system 1600 (FIG. 5) is implemented using 2-modules, such as node 1530, as the switching nodes of perfect shuffle equivalent network 1620 as well as in expansion section 1910 and concentration section 1930, the 2-modules of perfect shuffle equivalent network 1620 are individually disabled or enabled as necessary such that none of the 2-modules has more than one active input signal. The 2-modules of the last expansion node stage 1912 are also individually disabled or enabled (not shown in FIG. 5) such that a signal received at a given one of the N inlets is transmitted to only two 2-modules of node stage 1621-0. To improve the tolerance of system 1600 to faults, such as a particular 2-module output becoming locked at one logic value, all the expansion and concentration 2-modules may be controllable.

FIG. 9 is a diagram of a system 1601 having N=4 inlets and M=16 outlets. System 1601 is identical to system 1600 (FIG. 2) except that concentration section 1630 is not required.

FIG. 10 is a diagram of a system 1602 having N=16 inlets and M=4 outlets. System 1602 is identical to system 1600 (FIG. 2) except that expansion section 1610 is not required.

Before describing the blocking characteristics of systems such as system 1600, the fundamental principles of strictly nonblocking networks are discussed. The condition for a network to be strictly nonblocking is that the minimum number of paths between any input-output pair must exceed the maximum number of paths which can be blocked between that pair. However, a sufficient (but not necessary) condition for a network to be strictly nonblocking is that the minimum number of paths between any input-output pair exceeds the maximum number of paths which can be blocked between any input-output pair. In equation form, this sufficient condition is expressed as:

$$\text{PATHS} \geq \text{BLOCKED PATHS} + 1.$$

A helpful network attribute is that the number of paths and blocked paths varies only slightly (or not at all) for any input-output pair selection.

A single stage strictly nonblocking network 1002 is shown in FIG. 11. In network 1002, the minimum number of paths between any input-output pair is equal to one. There are no blocked paths because each horizontal rail is uniquely associated with an input and each vertical rail is uniquely associated with an output. Therefore, we have

$$\text{PATHS} = 1 \geq \text{BLOCKED PATHS} + 1 = 0 + 1.$$

Accordingly, network 1002 is a strictly nonblocking network. In network 1002, there are NxM crosspoints but only min {N,M} are ever used at one time. To make a more efficient network, multiple stages are employed so as to create more paths than possible blocked paths while simultaneously decreasing the number of crosspoints.

A 24x24 strictly nonblocking three stage Clos network 1004 is shown in FIG. 12. There are five paths between each inlet and outlet, one through each middle stage switch. Any inlet (outlet) may have two paths blocked by the other two inlets (outlets) on its switch. If these two pairs of blocked paths are disjoint, a total of four paths are blocked. Thus, applying the strictly nonblocking condition, we have  $5 \geq (2 + 2) + 1$ . The number of crosspoints in network 1004 is  $3 \times 5 \times 8 + 8 \times 8 \times 5 + 5 \times 3 \times 8 = 560$ . For comparison, a 24x24 crossbar network has 576 crosspoints.

A general strictly nonblocking three stage Clos network 1006 is shown in FIG. 13. (The inter-stage links are omitted in FIG. 13.) Applying the strictly nonblocking condition to network 1006, the minimum number of paths between any input-output pair is equal to  $r$ . The maximum number of blocked paths is equal to  $(n-1) + (m-1)$  and therefore whenever  $r \geq n + m - 1$ , network 1006 is strictly nonblocking. Note that a  $S+2$  stage Clos network can be recursively produced from an  $S$  stage Clos network by simply replacing each switch in a given stage with a three stage Clos network. A strictly nonblocking five stage Clos network 1008 as shown in FIG. 14 with the number of links between stages indicated thereon. Two problems in implementing Clos networks in the photonic domain are: 1) non-square, non-small switching elements, and 2) different numbers of links between stages (increasing geometrically toward the center).

A multistage interconnection network (MIN) 1010 is shown in FIG. 15 and is defined by the following five conditions:

- (1) a MIN has some arbitrary number  $S$  stages of nodes,
- (2) there are  $r_i$  nodes in stage  $i$ , each having  $n_i$  inputs and  $m_i$  outputs,
- (3) nodes in different stages may have different values of  $n_i$  and  $m_i$ ,
- (4) for  $1 \leq i \leq S-1$ , the outputs of nodes in stage  $i$  are connected (via links) to the inputs of nodes in stage  $i+1$ , and
- (5)  $r_i m_i = r_{i+1} n_{i+1}$  for  $1 \leq i \leq S-1$ .

An extended generalized shuffle (EGS) network 1012 is shown in FIG. 16. An EGS network is a MIN with a particular specified link interconnection pattern. In any stage  $i$  the nodes are numbered consecutively from 0 to  $r_i-1$  and the outputs on a particular node are numbered consecutively from 0 to  $m_i-1$ . The outputs of the stage  $i$  nodes are then numbered consecutively from 0 to  $r_i m_i-1$ ; output  $o_i$  on node  $x_i$  is numbered  $x_i m_i + o_i$ . The EGS interconnection pattern is stated as follows: stage  $i$  output  $x_i m_i + o_i$  is connected to node

$$(x_i m_i + o_i) \bmod r_{i+1}$$

in stage  $i+1$ . This interconnection pattern assigns links consecutively to nodes in the next stage (the so called perfect shuffle). An important implication of the EGS interconnection pattern is that the number of paths between any two nodes in two given stages never differs by more than one. For  $i < j$ , the number of paths between a node in stage  $i$  and a node in stage  $j$  is either

$$\left\lceil \prod_{k=i}^{j-1} m_k / r_j \right\rceil = \left\lfloor \prod_{k=i+1}^j n_k / r_i \right\rfloor \quad \text{or} \quad \left\lfloor \prod_{k=i}^{j-1} m_k / r_j \right\rfloor = \left\lceil \prod_{k=i+1}^j n_k / r_i \right\rceil,$$

where  $\lceil x \rceil$  denotes the smallest integer  $\geq x$  and  $\lfloor x \rfloor$  denotes the largest integer  $\leq x$ . Consider an EGS network with  $N = n_1 r_1$  inlets and  $m = m_s r_s$  outlets. The minimum number of paths between any inlet-outlet pair is given by

$$\left\lfloor \prod_{k=1}^{S-1} m_k / r_S \right\rfloor = \left\lfloor \prod_{k=1}^S m_k / M \right\rfloor = \left\lfloor \prod_{k=2}^S n_k / r_1 \right\rfloor = \left\lfloor \prod_{k=1}^S n_k / N \right\rfloor.$$

An example EGS network 1014 is shown in FIGS. 17 and 18. To determine the number of paths between input  $x$  and output  $y$ , we calculate

$$\text{Paths} = \left\lfloor \prod_{k=1}^S m_k / M \right\rfloor = \lfloor 3 \times 3 \times 2 \times 2 \times 1 / 12 \rfloor = \lfloor 36 / 12 \rfloor = 3.$$

The channel graph  $L(x,y)$  of input  $x$  and output  $y$  is the union of all paths between  $x$  and  $y$ . To ascertain an upperbound on the number of blocked paths, we must determine the number of calls which can intersect any channel graph and also the number of paths that each call can block. The channel graph  $L(x,y)$  is shown by dark lines in FIG. 19.

The channel graph  $L(x,y)$  is shown by dashed lines in FIG. 20. A single intersecting call (shown by dark lines in FIG. 20) blocks one of the three paths of  $L(x,y)$ . Consider a call that intersects  $L(x,y)$  on  $j$ -i links from node stage  $i$  to node stage  $j$  ( $j > i$ ). Denote a link from node stage  $k$  to node stage  $k+1$  as a stage  $k$  link. The number of paths between input  $x$  and output  $y$  blocked by link  $i$  of the intersecting call  $C(i,j)$  is given by the product of the number of paths from  $x$  to the stage  $i$  node of  $C(i,j)$  and the number of paths from the stage  $i+1$  node of  $C(i,j)$  to  $y$ . The maximum number of paths from any input (or stage 1 node) to any stage  $i$  node is

$$\left[ \prod_{k=2}^i n_k / r_1 \right] = \left[ \prod_{k=1}^i n_k / N \right]$$

and the maximum number of paths from any stage  $i+1$  node to any output (or stage  $S$  node) is

$$\left[ \prod_{k=i+1}^{S-1} m_k / r_S \right] = \left[ \prod_{k=i+1}^S m_k / M \right].$$

Thus, the maximum number of paths between  $x$  and  $y$  blocked by link  $i$  of  $C(i,j)$  is

$$\left[ \prod_{k=1}^i n_k / N \right] \times \left[ \prod_{k=i+1}^S m_k / M \right].$$

The additional number of paths blocked by link  $i+1$  is given by

$$\left[ \prod_{k=1}^{i+1} n_k / N \right] \times \left[ \prod_{k=i+2}^S m_k / M \right] - \left[ \prod_{k=1}^i n_k / N \right] \times \left[ \prod_{k=i+2}^S m_k / M \right].$$

The second term subtraction corrects for the fact that the first term includes some paths blocked by link  $i$ ; namely, all those paths reaching link  $i+1$  via link  $i$ . Employing a similar correction for each remaining link of  $C(i,j)$  we have that the number of paths blocked by  $C(i,j)$  is given by

$$\text{BLOCKED PATHS } (i,j) \leq \sum_{\bar{i}=1}^{j-1} \left[ \frac{\prod_{p=1}^{\bar{i}} n_p}{N} \right] \left[ \frac{\prod_{p=\bar{i}+1}^j m_p}{M} \right] - \sum_{\bar{i}=2}^{j-1} \left[ \frac{\prod_{p=1}^{\bar{i}} n_p}{N} \right] \left[ \frac{\prod_{p=\bar{i}+2}^j m_p}{M} \right].$$

Referring to network 1012 (FIG. 21), consider the following. Since  $n_1 \leq N$  and

$$\prod_{p=1}^k n_p$$

is nondecreasing in  $k$ , there must exist some stage  $t$  such that for  $1 \leq k \leq t$ ,

5 
$$\left[ \frac{\prod_{p=1}^k n_p}{N} \right] = 1$$

10 and for  $t + 1 \leq k \leq S$ ,

15 
$$\left[ \frac{\prod_{p=1}^k n_p}{N} \right] > 1.$$

Similarly, there must exist a stage  $u$  such that for  $u \leq k \leq S$ ,

20 
$$\left[ \frac{\prod_{p=k}^S m_p}{M} \right] = 1$$

25 and for  $1 \leq k \leq u - 1$ ,

30 
$$\left[ \frac{\prod_{p=k}^S m_p}{M} \right] > 1.$$

35 The relationship

40 
$$\left[ \frac{\prod_{p=1}^{t+1} n_p}{N} \right] > 1$$

45 implies that all inlets have at least one path to every stage  $t + 1$  node and therefore that intersecting call  $C(ij)$  must have  $i \leq t + 1$  and similarly, because

50 
$$\left[ \frac{\prod_{p=u-1}^S m_p}{M} \right] > 1,$$

55 must have  $j \geq u - 1$ . Using all of this information, we are able to establish that the expression for blocked paths becomes

$$\text{BLOCKED PATHS (i,j)} \leq \left[ \frac{\prod_{p=i+1}^S m_p}{M} + \left[ \frac{\prod_{p=1}^{j-1} n_p}{N} + \sum_{k=i+1}^{t-2} \left[ \frac{\prod_{p=1}^k n_p}{N} \right] \right] \right. \\ \left. \left[ \left[ \frac{\prod_{p=k+1}^S m_p}{M} \right] - \left[ \frac{\prod_{p=k+2}^S m_p}{M} \right] \right] - \left[ \frac{\prod_{p=i+2}^S m_p}{M} \right] \right] \times$$

where, conventionally, it is understood that the summation term

$$\sum_{k=i+1}^{t-2}$$

equals zero if  $t + 1 > u - 2$  and the product term

$$\prod_{p=i+2}^S$$

equals one if  $t + 2 > S$ . Note that

$$\left[ \frac{\prod_{p=i+1}^S m_p}{M} \right]$$

is a function of the entry point  $i$  and that

$$\left[ \frac{\prod_{p=1}^{j-1} n_p}{N} \right]$$

is a function of the departure point  $j$ . In addition,

$$\sum_{k=i+1}^{t-2} \left[ \frac{\prod_{p=1}^k n_p}{N} \right] \left[ \left[ \frac{\prod_{p=k+1}^S m_p}{M} \right] - \left[ \frac{\prod_{p=k+2}^S m_p}{M} \right] \right] - \left[ \frac{\prod_{p=i+2}^S m_p}{M} \right]$$

is a constant for all intersecting calls. Therefore, the upperbound on paths blocked by a single intersecting call is a separable function of the entry point, departure point, plus a constant.

We are now left with determining the maximum number of calls that can intersect a channel graph. Since the number of paths blocked by a single intersecting call is a separable function of the entry point, departure point, plus a constant, we need only determine the maximum number of calls which can enter

and depart at each stage. We do not have to associate the entry and departure points of a given call. We are now ready to consider an important property of EGS networks (called the forward-backward invariance property) which holds for any set of consecutive stages of the network meeting a particular condition. If the forward-backward invariance property holds for certain portions of the network, the maximum number of entering and departing calls at each stage can be drastically reduced.

The forward-backward invariance property (FBIP) can be stated as follows: every stage  $j$  node which can be reached by a given stage  $i$  node reaches exactly the same set of stage  $i$  nodes. The FBIP holds for stages  $i$  and  $j$  in an EGS network if

$$\prod_{k=i}^{j-1} m_k$$

divides  $r_j$ . The paths between certain stage 3 and stage 5 nodes for network 1014 are shown by dark lines in FIG. 22. Note that every stage 5 node which can be reached by a given stage 3 node reaches exactly the same set of stage 3 nodes. The FBIP is important because it drastically reduces intersecting calls and produces multistage modularity.

With reference to network 1012 shown in FIG. 23, assume that FBIP holds for stages 1 through  $i$ , i.e.,

$$\prod_{p=1}^{i-1} m_p$$

divides  $r_i$ . Thus, every stage  $i$  node which can be reached by some inlet  $x$  reaches exactly the same set of first stage nodes or inlets. Since any stage  $i$  node can reach at most

$$\prod_{p=1}^i n_p$$

inlets (the product of the  $n_p$  fanouts from stage  $i$  through stage 1), at most

$$\prod_{p=1}^i n_p - 1$$

calls can enter the channel graph  $L(x,y)$  from stage 1 through stage  $i$  (point A in FIG. 23). Similarly, if FBIP holds for stages  $i+2$  through  $S$ , then at most

$$\prod_{p=i+2}^S m_p - 1$$

calls can depart from stage  $i+2$  through stage  $S$  (point B in FIG. 23). For worst case considerations, we assume that all calls which enter at or before stage  $i$  depart at or before stage  $i+1$  and all calls which depart at or after stage  $i+2$  enter at or after stage  $i+1$ . Thus, for a given  $i$ ,  $1 \leq i \leq S-2$ , the number of calls intersecting a channel graph is upperbounded by

$$\prod_{p=1}^i n_p - 1 + \prod_{p=i+2}^S m_p - 1.$$

Minimizing for  $i$  and considering that at most  $\min\{N-1, M-1\}$  calls can intersect a channel graph, we have that the maximum number of calls  $\omega$  intersecting a channel graph is given by:

$$\omega = \min_{1 \leq i \leq S-2} \left( \prod_{p=1}^i n_p + \prod_{p=i+2}^S m_p - 2, N-1, M-1 \right).$$

5

The arguments which are used to obtain this result are valid FBIP holds for all stages 1 through i in which

10

$$\prod_{p=1}^i n_p \leq \omega$$

and also for all stages j through S in which

15

$$\prod_{p=j}^S m_p \leq \omega.$$

20

We have thus far determined that there are:

(1) at least

25

$$\left\lfloor \frac{\prod_{k=1}^S m_k}{M} \right\rfloor$$

paths between any input-output pair,

(2) at most

30

$$\left\lfloor \frac{\prod_{p=i+1}^S m_p}{M} \right\rfloor + \left\lfloor \frac{\prod_{p=1}^{i-1} n_p}{N} \right\rfloor + \sum_{k=i+1}^{S-2} \left\lfloor \frac{\prod_{p=1}^k n_p}{N} \right\rfloor \times \left( \left\lfloor \frac{\prod_{p=k+1}^S m_p}{M} \right\rfloor - \left\lfloor \frac{\prod_{p=k+2}^S m_p}{M} \right\rfloor \right) - \left\lfloor \frac{\prod_{p=i+2}^S m_p}{M} \right\rfloor$$

35

40

paths blocked by a call entering a channel graph at stage i and departing at stage j, and

(3) at most

45

$$\omega = \min_{1 \leq i \leq S-2} \left( \prod_{p=1}^i n_p + \prod_{p=i+2}^S m_p - 2, N-1, M-1 \right)$$

50

calls intersecting a channel graph if

55

$$\prod_{p=1}^i n_p \text{ divides } N \text{ for } \prod_{p=1}^i n_p \leq \omega \text{ and } \prod_{p=j}^S m_p \text{ divides } M \text{ for } \prod_{p=j}^S m_p \leq \omega.$$

So, all we have left to determine are the maximum numbers of calls which can enter and depart at each

stage of the channel graph.  
Recall that at most

5 
$$\prod_{p=1}^i n_p - 1$$

calls can enter L(x,y) in network 1012 (FIG. 23) at point A from stage 1 through stage i. But also, at most  $\omega$   
10 calls can enter from stage 1 through stage i. Also recall that at most

15 
$$\prod_{p=i+2}^S m_p - 1$$

calls can depart L(x,y) from point B of network 1012 from stage i+2 through stage S. But also, at most  $\omega$   
calls can depart from stage i+2 through stage S. Thus, as many as

20 
$$\min\left(\prod_{p=1}^i n_p - 1, \omega\right)$$

calls can enter from stage 1 through stage i, and as many as

25 
$$\min\left(\prod_{p=1}^{i-1} n_p - 1, \omega\right)$$

calls can enter from stage 1 through stage i-1. Assuming a maximum number of calls entering through  
30 stage i-1, we have at most

35 
$$\min\left(\prod_{p=1}^i n_p - 1, \omega\right) - \min\left(\prod_{p=1}^{i-1} n_p - 1, \omega\right)$$

calls entering at stage i. And similarly, we have at most

40 
$$\min\left(\prod_{p=i}^S m_p - 1, \omega\right) - \min\left(\prod_{p=i+1}^S m_p - 1, \omega\right)$$

calls departing at stage i. We are now able to state the fundamental condition for strictly nonblocking EGS  
45 networks:

50

55

$$\begin{aligned}
 & \left\lfloor \frac{\prod_{k=1}^s m_k}{M} \right\rfloor \geq \\
 5 & \sum_{i=1}^s \left[ \left( \min \left( \prod_{p=1}^i n_p - 1, \omega \right) - \min \left( \prod_{p=1}^{i-1} n_p - 1, \omega \right) \right) \times \left\lfloor \frac{\prod_{p=i+1}^s m_p}{M} \right\rfloor + \right. \\
 10 & \left. \left( \min \left( \prod_{p=1}^s m_p - 1, \omega \right) - \min \left( \prod_{p=i+1}^s m_p - 1, \omega \right) \right) \times \left\lfloor \frac{\prod_{p=1}^{i-1} n_p}{N} \right\rfloor + \omega \times \left[ \sum_{k=i+1}^{s-2} \left\lfloor \frac{\prod_{p=1}^k n_p}{N} \right\rfloor \times \right. \right. \\
 15 & \left. \left. \left( \left\lfloor \frac{\prod_{p=k+1}^s m_p}{M} \right\rfloor - \left\lfloor \frac{\prod_{p=k+2}^s m_p}{M} \right\rfloor \right) - \left\lfloor \frac{\prod_{p=i+2}^s m_p}{M} \right\rfloor \right) + 1, \right. \\
 20 & \left. \right]
 \end{aligned}$$

where

$$\left\lfloor \frac{\prod_{k=1}^s m_k}{M} \right\rfloor$$

is the minimum number of paths between any input-output pair,

$$\min \left( \prod_{p=1}^i n_p - 1, \omega \right) - \min \left( \prod_{p=1}^{i-1} n_p - 1, \omega \right)$$

is the maximum number of entering calls at stage  $i$ ,

$$\left\lfloor \frac{\prod_{p=i+1}^s m_p}{M} \right\rfloor$$

is the number of paths blocked by calls entering at stage  $i$ ,

$$\min \left( \prod_{p=1}^s m_p - 1, \omega \right) - \min \left( \prod_{p=i+1}^s m_p - 1, \omega \right)$$

is the maximum number of departing calls at stage  $i$ ,

$$\left\lfloor \frac{\prod_{p=1}^{i-1} n_p}{N} \right\rfloor$$

is the number of paths blocked by the call departing at stage i,  $\omega$  is the maximum number of intersecting calls, and

$$\sum_{k=t+1}^{u-2} \left[ \frac{\prod_{p=1}^k n_p}{N} \right] \left( \left[ \frac{\prod_{p=k+1}^s m_p}{M} \right] - \left[ \frac{\prod_{p=k+2}^s m_p}{M} \right] \right) - \left[ \frac{\prod_{p=t+2}^s m_p}{M} \right]$$

is a constant component of blocked paths for all intersecting calls.

This can then be stated as a fundamental theorem for strictly nonblocking EGS networks: any EGS network which has  $N = \prod_{p=1}^i n_p$  inlets and  $M = \prod_{p=1}^s m_p$  outlets and in which

$$\prod_{p=1}^i n_p \text{ divides } N \text{ for } \prod_{p=1}^i n_p \leq \omega \text{ and } \prod_{p=j}^s m_p \text{ divides } M \text{ for } \prod_{p=j}^s m_p \leq \omega,$$

and in which

$$\left[ \frac{\prod_{k=1}^s m_k}{M} \right] \geq \omega \times \left( \sum_{k=t+1}^{u-2} \left[ \frac{\prod_{p=1}^k n_p}{N} \right] \left( \left[ \frac{\prod_{p=k+1}^s m_p}{M} \right] - \left[ \frac{\prod_{p=k+2}^s m_p}{M} \right] \right) - \left[ \frac{\prod_{p=t+2}^s m_p}{M} \right] \right) + 1 + \sum_{i=1}^s \left( \left( \min \left( \prod_{p=1}^i n_p - 1, \omega \right) - \min \left( \prod_{p=1}^{i-1} n_p - 1, \omega \right) \right) \times \left[ \frac{\prod_{p=i+1}^s m_p}{M} \right] + \left( \min \left( \prod_{p=1}^s m_p - 1, \omega \right) - \min \left( \prod_{p=1}^{s-i} m_p - 1, \omega \right) \right) \times \left[ \frac{\prod_{p=1}^{i-1} n_p}{N} \right] \right),$$

where t is the largest value of i such that

$$\prod_{p=1}^i n_p \leq N,$$

u is the smallest value of i such that

$$\prod_{p=1}^s m_p \leq M,$$

and

$$\omega = \min_{1 \leq i \leq S-2} \left( \prod_{p=1}^i n_p + \prod_{p=i+2}^S m_p - 2, N-1, M-1 \right)$$

is strictly nonblocking for point-to-point connections.

The previous development assumed full capacity nodes (capacity = min{n<sub>i</sub>, m<sub>i</sub>}). Similar developments can be made for capacity one nodes with selectivity, and for capacity one nodes without selectivity. Separate results are merged via the introduction of a variable α, where α = 1 for full capacity nodes, α = 0 for capacity one nodes with selectivity, and α = -1 for capacity one nodes without selectivity. The fundamental theorem for strictly nonblocking EGS networks is then stated as follows: any EGS network (where α = 1 for full capacity nodes, α = 0 for capacity one nodes with selectivity, and α = -1 for capacity one nodes without selectivity) which has N = n<sub>1</sub>r<sub>1</sub> inlets and M = m<sub>s</sub>r<sub>s</sub> inlets and in which

$$\prod_{p=1}^i n_p \text{ divides } N \text{ for } \prod_{p=1}^i n_p \leq \omega \text{ and } \prod_{p=j}^S m_p \text{ divides } M \text{ for } \prod_{p=j}^S m_p \leq \omega,$$

and in which

$$\left\lfloor \frac{\prod_{k=1}^S m_k}{M} \right\rfloor \geq \omega \times \left( \sum_{k=t+1}^{u-1-\alpha} \left\lfloor \frac{\prod_{p=1}^k n_p}{N} \right\rfloor \left( \left\lfloor \frac{\prod_{p=k+\alpha}^S m_p}{M} \right\rfloor - \left\lfloor \frac{\prod_{p=k+1+\alpha}^S m_p}{M} \right\rfloor \right) + 1 + \sum_{i=1}^S \left( \left( \min \left( \prod_{p=1}^i n_p - 1, \omega \right) - \min \left( \prod_{p=1}^{i-1} n_p - 1, \omega \right) \right) \times \left\lfloor \frac{\prod_{p=i+\alpha}^S m_p}{M} \right\rfloor + \left( \min \left( \prod_{p=1}^S m_p - 1, \omega \right) - \min \left( \prod_{p=i+1}^S m_p - 1, \omega \right) \right) \times \left\lfloor \frac{\prod_{p=1}^{i-\alpha} n_p}{N} \right\rfloor \right),$$

where t is the largest value of i such that

$$\prod_{p=1}^i n_p \leq N,$$

u is the smallest value of i such that

$$\prod_{p=1}^S m_p \leq M,$$

and

$$\omega = \min_{1 \leq i \leq S-1} \left( \prod_{p=1}^i n_p + \prod_{p=i+1}^S m_p - 2, N-1, M-1 \right)$$

is strictly nonblocking for point-to-point connections.

The great design flexibility of EGS networks stems primarily from the fact that the conditions for nonblocking operation are global and are based solely on  $N$ ,  $M$ ,  $\alpha$ , and various  $n_i$  and  $m_i$  products. Thus, in

general, nonblocking conditions do not depend on the relationship between a particular  $n_i$  and  $m_i$ .  
An example nonblocking EGS network 1016 is shown in FIG. 24. If the output links in each stage of this network are assigned consecutively to the nodes in the next stage (perfect shuffle), then any idle input can be connected to any idle output, regardless of the current connection state of the network, i.e., the network is strictly nonblocking.

A multistage interconnection network (MIN)  $G$  is said to be a perfect shuffle equivalent network if either of the following two conditions holds.

Condition 1:

For every stage  $i$  of  $G$  there exists a one-to-one mapping  $\phi_i$  from the  $r_i$  stage  $i$  nodes of  $G$  onto the integer set  $\{0, 1, \dots, r_i-1\}$  such that node  $\alpha$  in stage  $i$  of  $G$  is connected to node  $\beta$  in stage  $i+1$  of  $G$  if and only if

$$\phi_{i+1}(\beta) \in \left\{ \left( \phi_i(\alpha) \times m_i + o_i \right)_{\text{mod } r_{i+1}} : o_i \in \{0, 1, \dots, m_i-1\} \right\}.$$

Condition 2:

For every stage  $i$  of  $G$  there exists a one-to-one mapping  $\psi_i$  from the  $r_i$  stage  $i$  nodes of  $G$  onto the integer set  $\{0, 1, \dots, r_i-1\}$  such that node  $\beta$  in stage  $i+1$  of  $G$  is connected to node  $\alpha$  in stage  $i$  of  $G$  if and only if

$$\psi_i(\alpha) \in \left\{ \left( \psi_{i+1}(\beta) \times n_{i+1} + i_{i+1} \right)_{\text{mod } r_i} : i_{i+1} \in \{0, 1, \dots, n_{i+1}-1\} \right\}.$$

Note that an EGS network is a perfect shuffle equivalent network in that Condition 1 holds when each  $\phi_i$  is simply the identity mapping. Let  $C_1 = \{\phi_i : i \in \{1, 2, \dots, S\}\}$  represent a set of  $S$  mappings  $\phi_i$  satisfying Condition 1 and let  $C_2 = \{\psi_i : i \in \{1, 2, \dots, S\}\}$  represent a set of  $S$  mappings satisfying Condition 2.

An expanding means is said to connect each of the  $N$  inlets of  $G$  to multiple inputs of the first stage nodes of  $G$  in a perfect shuffle sustaining pattern if either of the following two conditions holds.

Condition 1e:

$C_1$  exists,

$$\frac{n_1 r_1}{N} = F,$$

an integer, and there exists a one-to-one mapping  $\phi_1$  from the  $N$  inlets of  $G$  onto the integer set  $\{0, 1, \dots, N-1\}$  such that inlet  $\alpha$  is connected to node  $\beta$  in stage 1 of  $G$  if and only if

$$\phi_1(\beta) \in \left\{ \left[ \phi_1(\alpha) \times F + o_1 \right]_{\text{mod } r_1} : o_1 \in \{0, 1, \dots, F-1\} \right\}, \text{ where } \phi_1 \in C_1.$$

5

Condition 2a:C<sub>2</sub> exists,

10

$$\frac{n_1 r_1}{N} = F,$$

15 an integer, and there exists a one-to-one mapping  $\psi_1$  from the N inlets of G onto the integer set  $\{0, 1, \dots, N-1\}$  such that node  $\beta$  in stage 1 of G is connected to inlet  $\alpha$  of G if and only if

$$20 \quad \psi_1(\alpha) \in \left\{ \left[ \psi_1(\beta) \times n_1 + i_1 \right]_{\text{mod } N} : i_1 \in \{0, 1, \dots, n_1-1\} \right\}, \text{ where } \psi_1 \in C_2.$$

A concentrating means is said to connect multiple outputs of the last stages of nodes of G to each of the M outlets of G in a perfect shuffle sustaining pattern if either of the following two conditions holds.

25

Condition 1c:C<sub>1</sub> exists,

30

$$\frac{n_s r_s}{M} = F',$$

35 an integer, and there exists a one-to-one mapping  $\phi_o$  from the M outlets of G onto the integer set  $\{0, 1, \dots, M-1\}$  such that node  $\alpha$  in stage S of G is connected to outlet  $\beta$  if and only if

$$40 \quad \phi_o(\beta) \in \left\{ \left[ \phi_o(\alpha) \times m_s + o_s \right]_{\text{mod } M} : o_s \in \{0, 1, \dots, m_s-1\} \right\}, \text{ where } \phi_o \in C_1.$$

Condition 2c:

45

C<sub>2</sub> exists,

$$\frac{n_s r_s}{N} = F',$$

50

an integer, and there exists a one-to-one mapping  $\psi_o$  from the M outlets of G onto the integer set  $\{0, 1, \dots, M-1\}$  such that outlet  $\beta$  is connected to node  $\alpha$  in stage S of G if and only if

$$55 \quad \psi_o(\alpha) \in \left\{ \left[ \psi_o(\beta) \times F' + i_o \right]_{\text{mod } r_s} : i_o \in \{0, 1, \dots, F'-1\} \right\}, \text{ where } \psi_o \in C_2.$$

Network G with such expanding and concentrating means can be equivalently represented as an S + 2 stage perfect shuffle equivalent network comprised of an expansion stage of N 1xF nodes, followed by the S stages of G, followed by a concentration stage of M<sub>p</sub> F'x1 nodes. If Condition 1(2) holds, φ<sub>1</sub>(ψ<sub>1</sub>) is applied to the N inlet nodes and inlet node α is connected to node β in stage 1 of G according to Condition 1e (2e) and φ<sub>0</sub>(ψ<sub>0</sub>) is applied to the M outlet nodes and node α in stage S of G is connected to outlet node β according to Condition 1c (2c). The above theorem on strictly non-blocking conditions applies to such networks.

Crossover network 1020 shown in FIG. 25 is a perfect shuffle equivalent network. This can easily be verified by examining the labeling of the nodes in each stage and the interconnection between stages. The existence of such regularized physical interconnection patterns of perfect shuffle equivalent networks is important for implementation consideration.

In a crossover network with 2<sup>k</sup>, 2 x 2 nodes per stage, each link stage i is comprised of a crossover interconnection pattern having 2<sup>i</sup> partitions, where r<sub>i</sub> ∈ I(k) = {0,1,...,k-1}. The values selected for the various r<sub>i</sub> greatly affect the performance and connectivity of the network.

One very useful pattern of r<sub>i</sub> selection (that produces a perfect shuffle equivalent network) is to have r<sub>1</sub>, r<sub>2</sub>, ..., r<sub>k</sub> be given by any permutation of I(k) and for i ≥ k, r<sub>i</sub> = r<sub>j</sub> where j = 1 + (i-1) mod k; i.e. r<sub>k+1</sub> = r<sub>1</sub>, r<sub>k+2</sub> = r<sub>2</sub>, ..., r<sub>2k</sub> = r<sub>k</sub>, etc. Many other useful patterns exist that correspond to networks not in the perfect shuffle equivalent network family.

EGS network 1022 shown in FIG. 26 represents an important special case of perfect shuffle equivalent networks. In network 1022

S ≥ 3, n<sub>1</sub> = 1, m<sub>1</sub> = F, r<sub>1</sub> = N, n<sub>S</sub> = F, M<sub>S</sub> = 1, r<sub>S</sub> = N, and for 2 ≤ i ≤ S-1, n<sub>i</sub> = m<sub>i</sub> = n, and r<sub>i</sub> =  $\frac{FN}{n}$ .

LET:

P(B) = probability that a given idle inlet and outlet cannot be connected (blocked).

P(F) = probability that a given nxn node in stages 2 through S-1 is unusable due to a failure.

OCC = probability that a given inlet or outlet is busy.

α = 0 for capacity one nxn nodes (with selectivity).

α = 1 for full capacity nxn nodes.

THEN:

N, F, n, S, P(B), OCC, and α are approximately related by

$$P(B) \approx \left[ 1 - \left[ 1 - P(F) - \frac{(n-1)OCC}{n^\alpha F} \right]^{S-2-\alpha} \right]^{\frac{FN^{S-2}}{N}}$$

For 3 ≤ S ≤ 2log<sub>n</sub>N + 1 - α

LET:

P<sub>s</sub>(B) = P(B) for a network with S stages

THEN:

P<sub>S+1</sub>(B) and P<sub>s</sub>(B) are approximately related by

$$P_{S+1}(B) \approx P_s(B)^{[n(1-P(F)) - (n-1)n^{1-\alpha} \times OCC/F]}$$

If

$$F > \frac{(n-1)OCC}{n^\alpha(1-P(F))},$$

then the exponent is greater than one and  $P_S(B)$  decreases double exponentially in  $S$ ; i.e.,

5 
$$\log \left( \log \frac{1}{P_S(B)} \right)$$

plotted versus  $S$  is a straight line. To demonstrate this dramatic effect assume  $P_S(B) = 10^{-1}$  and  $P_{S+1}(B) = [PS(B)]^2$ . Then  $P_{S+1} = (10^{-1})^2 = 10^{-2}$ ,  $P_{S+2}(B) = [10^{-2}]^2 = 10^{-4}$ ,  $P_{S+3}(B) = [10^{-4}]^2 = 10^{-8}$ ,  $P_{S+4}(B) = [10^{-8}]^2 = 10^{-16}$ , etc. Thus, in such a network we have reduced the probability of blocking from  $10^{-1}$  to  $10^{-16}$  by simply adding four stages.

10 The previous approximate expression for probability of blocking may be generalized for any perfect shuffle equivalent network  $G$  with  $S$  stages of nodes, with stage  $i$  comprised of  $n_i \times m_i$  nodes and with  $N = n_1 r_1$  inlets and  $M = r_s m_s$  outlets. Setting  $P(F)=0$ ,  $OCC=1$ , and  $\alpha=1$  we get the probability of blocking in  $G$ ,  $P(G)$ , approximately given by

15 
$$P(G) \approx \left[ \prod_{i=1}^{S-1} \left[ 1 - \frac{(n_i - 1) \prod_{j=1}^{i-1} n_j}{\prod_{j=1}^i m_j} \right] \right]^{\prod_{j=1}^S m_j / M}$$

$P(G) \leq .5$  is a conservative threshold for network  $G$  to be useful in applications where blocking probability is at all significant.

25 **Network Control**

Recall that network 1012, shown in FIG. 16, is an EGS network having an interconnection pattern that simply assigns links consecutively to switches in the next stage--a perfect shuffle interconnection. The number of paths  $P$  between any inlet  $x$  and, any outlet  $y$  in network 1012 is given by

30 
$$P = 1 + \left\lfloor \frac{\prod_{j=1}^S m_j - 1 - (y - x \prod_{j=1}^S m_j)_{\text{mod } M}}{M} \right\rfloor$$

Let  $I(k)$  denote the integer set  $\{0,1,\dots,k-1\}$ . Denote a given path from inlet  $x$  to outlet  $y$  by the triple  $(x, P^*, y)$ , where  $P^*$  is an element of  $I(P)$ . Path  $(x, P^*, y)$  will pass through stage  $i$  switch

35 
$$S_i(x, P^*, y) = \left\lfloor \frac{x \prod_{j=1}^S m_j = P^* M + (y - x \prod_{j=1}^S m_j)_{\text{mod } M}}{\prod_{j=1}^S m_j} \right\rfloor_{\text{mod } r_i}$$

40 for  $1 \leq i \leq S$ . Denote a link between stages  $i$  and  $i + 1$  as a stage  $i$  link. Path  $(x, P^*, y)$  utilizes stage  $i$  link

45 
$$L_i(x, P^*, y) = \left\lfloor \frac{x \prod_{j=1}^S m_j + P^* M + (y - x \prod_{j=1}^S m_j)_{\text{mod } M}}{\prod_{j=i+1}^S m_j} \right\rfloor_{\text{mod } r_i m_i}$$

for  
 $1 \leq i \leq S - 1$ .

FIG. 27 is a path hunt processing flow chart used to effect the path hunt function in network 1012 where the switches are full capacity, i.e.,  $cap(S_i) = \min\{n_i, m_i\}$ . Processing begins with block 1102 where a previously unchecked path  $P^*$  is selected. In block 1104 the busy/idle status of  $L_i(x, P^*, y)$  is checked for all  $1 \leq i \leq S - 1$ . In decision block 1106 a determination is made of whether all the  $L_i(x, P^*, y)$  are idle. If all the  $L_i(x, P^*, y)$  are idle, processing proceeds from block 1106 to block 1108 where it is concluded that path  $P^*$  may be used to connect inlet  $x$  to outlet  $y$ . If it is determined in block 1106 that all the  $L_i(x, P^*, y)$  are not idle, processing continues with decision block 1110. In block 1110 it is determined whether there are other unchecked paths. If there are, processing returns to block 1102 and the processing flow chart is repeated for a new unchecked path. However, if in decision block 1110 it is determined that there are no other unchecked paths, processing branches to block 1112 where it is concluded that all paths are blocked between inlet  $x$  and outlet  $y$ . The links  $L_i$  are checked in the flow chart of FIG. C1 because the switches of network 1012 were assumed to be full capacity.

FIG. 28 is a path hunt processing flow chart used to effect the path hunt function in network 1012 where the switches are capacity one, i.e.,  $cap(S_i) = 1$ . Processing begins with block 1122 where a previously unchecked path  $P^*$  is selected. In block 1124 the busy/idle status of  $S_i(x, P^*, y)$  is checked for all  $i, 1 \leq i \leq S$ . In decision block 1126 a determination is made of whether all the  $S_i(x, P^*, y)$  are idle. If all the  $S_i(x, P^*, y)$  are idle processing proceeds from block 1126 to block 1128 where it is concluded that path  $P^*$  may be used to connect inlet  $x$  to outlet  $y$ . If it is determined in block 1126 that all the  $S_i(x, P^*, y)$  are not idle, processing continues with decision block 1130. In block 1130 it is determined whether there are other unchecked paths. If there are, processing returns to block 1122 and the processing flow chart is repeated for a new unchecked path. However, if in decision block 1130 it is determined that there are no other unchecked paths, processing branches to block 1132 where it is concluded that all paths are blocked between inlet  $x$  and outlet  $y$ . The switches  $S_i$  are checked in the flow chart of FIG. 28 because the switches of network 1012 were assumed to be of capacity one.

It is significant to note that in performing the path hunt for network 1012, parallel operations are possible. All  $S_i(x, P^*, y)$  or  $L_i(x, P^*, y)$  busy/idle statuses for all  $i$  and  $P^*$  may be read concurrently, and then all  $P$  paths can be determined busy or idle concurrently. A specific path is then chosen from those found idle, if any.

If the network under consideration is not an EGS network, but is an isomorphic version of an EGS network, inlet  $x$  and outlet  $y$  must be mapped into their EGS equivalents before applying the routing algorithm(s). A reverse mapping is required to operate switches.

Overlap operation can be performed on a multiplicity of connections to be made if all paths for each inlet/outlet pair are disjoint from all paths for every other inlet/outlet pair.

For convenience, denote

$$\prod_{j=1}^S m_j = M_1.$$

If  $M$  divides  $M_1$ , the equations for  $P, S_i(x, P^*, y)$ , and  $L_i(x, P^*, y)$  given previously become

$$P = \frac{M_1}{M},$$

$$S_i(x, P^*, y) = \left[ \frac{xM_1 + P^*M + y}{M_i} \right]_{\text{mod } r_i}, \text{ and}$$

$$L_i(x, P^*, y) = \left[ \frac{xM_1 + P^*M + y}{M_{i+1}} \right]_{\text{mod } r_i, m_i}.$$

Consider a network G in which  $N = M = 2^n$ ,  $n_1 = m_s = 1$ ,  $m_1 = n_s = 2^k = F$ , and, for  $2 \leq i \leq S-1$ ,  $n_i = m_i = 2$ , where  $n$  and  $k$  are integers. Then

5 
$$M_1 = 2^{S-2} \times F = 2^{S-2} \times 2^k = 2^{S+k-2} \text{ and } P = \frac{M_1}{M} = \frac{2^{S+k-2}}{2^n} = 2^{S+k-n-2}.$$

We also have  $r_1 = r_s = N = M = 2^n$  and

10

$$r_i = \frac{2^n \times 2^k}{2} = 2^{n+k-1}$$

15 for  $2 \leq i \leq S-1$ . Additionally,  $M_i = 2^{S-i}$  for  $2 \leq i \leq S$ .

The term  $xM_1 + P^*M + y$  thus becomes  $x2^{S+k-2} + P^*2^n + y$ ,  $x$  and  $y$  range through integer values  $0, 1, \dots, 2^n-1$  and  $P^*$  ranges through integer values  $0, 1, \dots, 2^{S+k-n-2}-1$ . Thus,  $P^*2^n$  has values  $0, 2^n, 2 \cdot 2^n, 3 \cdot 2^n, \dots, 2^{S+k-2} \cdot 2^n$  and  $P^*2^n + y$  ranges through all integer values from 0 to  $2^{S+k-2} \cdot 2^n$ . Also,  $x \cdot 2^{S+k-2}$  has values  $0, 2^{S+k-2}, \dots, 2^{S+k+n-2} \cdot 2^{S+k-2}$  and thus  $x2^{S+k-2} + P^*2^n + y$  ranges through all integer values from 0 to  $2^{S+k+n-2} \cdot 2^{S+k-2}$ .

20

We can thus represent  $xM_1 + P^*M + y = x2^{S+k-2} + P^*2^n + y$  as an  $S + k + n - 2$  bit binary number as follows

25

$$xM_1 + P^*M + y = \underbrace{xx \dots x}_n \underbrace{pp \dots p}_{S+k-n-2} \underbrace{yy \dots y}_n.$$

Let us consider the expression

30

$$S_i(x, P^*, y) = \left\lfloor \frac{xM_1 + P^*M + y}{M_i} \right\rfloor_{\text{mod } r_i} = \left\lfloor \frac{xM_1 + P^*M + y}{2^{S-i}} \right\rfloor_{\text{mod } 2^{n+k-1}}$$

35

for  $2 \leq i \leq S-1$ . Dividing a binary number by  $2^{S-i}$  and taking the floor function is equivalent to shifting the binary number  $S-i$  places to the right. Thus,

40

$$\left\lfloor \frac{xM_1 + P^*M + y}{2^{S-i}} \right\rfloor$$

is equivalent to the binary number enclosed in the following rectangle:

45

$$\boxed{\underbrace{xx \dots x}_{k+n+i-2} \cdot \underbrace{pp \dots p}_{S-i} \cdot \underbrace{yy \dots y}_n}$$

A binary number modulo  $2^{n+k-1}$  is given by the rightmost  $n+k-1$  bits of the binary number. Thus,

50

$$\left\lfloor \frac{xM_1 + P^*M + y}{2^{S-i}} \right\rfloor_{\text{mod } 2^{n+k-1}}$$

55

is equivalent to the binary number enclosed in the following rectangle:



5

$S_i(x, P^*, y)$  is thus given by a window of  $\log_2 r_i$  bits displaced  $\log_2 M_i$  bits from the right of the binary representation of  $xM_1 + P^*M + y$ . Similarly,  $L_i(x, P^*, y)$  is given by a window of  $\log_2(r_i m_i)$  bits displaced by  $\log_2 M_{i+1}$  bits from the right of the binary representation of  $xM_1 + P^*M + y$ .

10

The relationship of the switches and links of a shuffle network to the inlet/outlet and path numbers is described herein for the exemplary network 1140, shown in FIG. 29. FIG. 30 illustrates the concatenation of binary representations of inlet 137, path 417, and outlet 291 to form a single binary number. FIG. 31 illustrates that the determination of a particular switch in a given stage can be made simply by selecting a certain number of consecutive bits of the binary number. The particular eleven-bit sequences used to identify the stage 2 switch and the stage 16 switch are illustrated in FIG. 31. Similarly, the twelve-bit sequences used to identify the particular links in stage 2 and stage 16 are also illustrated. The eleven-bit strings identify one out of 2048 switches. The twelve-bit strings identify one out of 4096 links. Also illustrated in FIG. 31 is the method for identifying the particular inputs and outputs of the various stages, based on the bit(s) adjacent to the bit sequences used to identify the switches and links. For example, the stage 2 and stage 16 inputs are identified and the stage 1, stage 2 and stage 16 outputs are identified. Note that for network 1140, output routing is "self-routing" -- independent of the input.

15

20

Recall that the crossover network and the shuffle network are isomorphic. The transformations between various stages of the two network types are illustrated schematically in FIG. 32. The particular transformations identified in FIG. 32 are listed herein in Tables 1-3. In FIG. 32 the switch and output of stage  $i$  of a crossover network identified in block 1150 and the switch and output of a shuffle network stage  $i$  identified in block 1154 are related by transformations 1, 2, 3, and 4 of block 1152. Similarly, the switch and input for stage  $i+1$  of a crossover network represented in block 1160 and the switch and input for stage  $i+1$  of a shuffle network represented in block 1164 are related as defined by transformations 9, 10, 11, and 12 of block 1162. The transformations between stage  $i$  switch and output number for a crossover network and stage  $i+1$  switch and input number for a crossover network are specified by transformations 13, 14, 15, and 16 of block 1156. The corresponding relationships between successive stages of a shuffle network are given by transformations 5, 6, 7, and 8 of block 1158. The transformations 1 through 16 are listed in Tables 1-3. For each transformation, the number to be transformed is a  $n$ -bit binary number represented by  $B_{n-1} \dots B_1 B_0$ .

30

35

40

45

50

55

5	(1) $CS_i \rightarrow SS_i:$ $\overbrace{B_{i+1} \oplus B_i, B_{i+2} \oplus B_{i+1}, \dots, B_{n-1} \oplus B_{n-2}}^{n-i-1}, \overbrace{B_{n-1}}^1,$ $\overbrace{B_1 \oplus B_0, B_2 \oplus B_1, \dots, B_i \oplus B_{i-1}}^i$
10	
15	(2) $CO_i \rightarrow SO_i:$ $B_{i+1} \oplus B_i \oplus CO_i$ if $i \leq n-2$ ; $B_{n-1} \oplus CO_i$ if $i=n-1$
20	(3) $SS_i \rightarrow CS_i:$ $\overbrace{B_i, B_{i+1} \oplus B_i, B_{i+2} \oplus B_{i+1} \oplus B_i, \dots, \oplus B_{n-1, \dots, i}}^{n-i}$ $\overbrace{\oplus B_{n-1, \dots, i, 0}, \dots, \oplus B_{n-1, \dots, i, i-1}}^i$
25	
30	(4) $SO_i \rightarrow CO_i:$ $B_{n-i} \oplus SO_i$
35	
40	(5) $SS_i, SO_i \rightarrow SS_{i+1}:$ $B_{n-2}, B_{n-3}, \dots, B_0, SO_i$
45	(6) $SS_i, SO_i \rightarrow SI_{i+1}:$ $B_{n-1}$

TABLE 1

50

55

(7)  $SS_{i+1}, SI_{i+1} \rightarrow SS_i: SI_{i+1}, B_{n-1}, B_{n-2}, \dots, B_1$

(8)  $SS_{i+1}, SI_{i+1} \rightarrow SO_i: B_0$

(9)  $CS_{i+1} \rightarrow SS_{i+1}:$

$$\frac{\overbrace{B_{i+2} \oplus B_{i+1}, B_{i+3} \oplus B_{i+2}, \dots, B_{n-1} \oplus B_{n-2}, B_{n-1}}^{n-i-2}}{\overbrace{B_1 \oplus B_0, B_2 \oplus B_1, \dots, B_{i+1} \oplus B_i}^{i+1}}$$

(10)  $CI_{i+1} \rightarrow SI_{i+1}: B_{i+1} \oplus B_i \oplus CI_{i+1}$  if  $i+1 \geq 1$ ;  
 $B_{n-1} \oplus CI_{i+1}$  if  $i+1=0$

(10a)  $CI_i \rightarrow SI_i: B_i \oplus B_{i-1} \oplus CI_i$  if  $i \geq 1$ ;  
 $B_{n-1} \oplus CI_i$  if  $i=0$

(11)  $SS_{i+1} \rightarrow CS_{i+1}:$

$$\frac{\overbrace{B_{i+1}, B_{i+2} \oplus B_{i+1}, B_{i+3} \oplus B_{i+2} \oplus B_{i+1}, \dots, \oplus B_{n-1, \dots, i+1}}^{n-i-1}}{\overbrace{\oplus B_{n-1, \dots, i+1, 0}, \dots, \oplus B_{n-1, \dots, i+1, 0, \dots, i}}^{i+1}}$$

TABLE 2

5	(12) $SI_{i+1} \rightarrow CI_{i+1}: B_0 \oplus SI_{i+1}$
10	(12a) $SI_i \rightarrow CI_i: B_0 \oplus SI_i$
15	(13) $CS_i, CO_i \rightarrow CS_{i+1}:$
20	$\overbrace{B_{n-1}, B_{n-2}, \dots, B_{i+1}}^{n-i-1}$ $\overbrace{B_i \oplus CO_i, B_{i-1} \oplus CO_i, \dots, B_0 \oplus CO_i}^{i+1}$
25	(14) $CS_i, CO_i \rightarrow CI_{i+1}: CO_i$
30	(15) $CS_{i+1}, CI_{i+1} \rightarrow CS_i:$
35	$\overbrace{B_{n-1}, B_{n-2}, \dots, B_{i+1}}^{n-i-1}$ $\overbrace{B_i \oplus CI_{i+1}, B_{i-1} \oplus CI_{i+1}, \dots, B_0 \oplus CI_{i+1}}^{i+1}$
40	(16) $CS_{i+1}, CI_{i+1} \rightarrow CO_i: CI_{i+1}$

45

TABLE 3

50 Arrangements for controlling a 512x512 crossover network 1200 (FIG. 38) are now described. To get a better understanding of the size of such a network, first refer to the 16x16 crossover network 1170 (FIGS. 34-36) and note the pattern of crossover connections from stage to stage. FIG. 37 is a representation of the relative sizes of the 16x16 network 1170 and the 512x512 network 1200. Also shown is an intermediate size 128x128 network. Crossover network 1200 (FIG. 38) includes 15 stages; however stages 1, 2, 3, 13, 14, and 15 do not perform a switching function but are used only to implement the fanout/fanin F=8. A crossover network controller 1300 is used to effect path hunt, connect, and disconnect functions for network 1200 via 55 a plurality of stage controllers 1201 through 1209, individual to the stages 4 through 12. For the present example, the nodes of the switching stages 4 through 12 are full capacity switching nodes such as the node of FIG. 5. The nodes of the fanout stages 1, 2 and 3 and the nodes of the fanin stages 13, 14, and 15 are

simple fanout elements and fanin elements, respectively. Crossover network controller 1300, which may be implemented as a single processor operated under stored program control or as a hardware logic circuit arrangement, implements the control processing shown, for example, in FIGS. 39 and 40 to effect connections and disconnections respectively.

5 Connection processing (FIG. 39) begins when a network 1200 inlet/outlet pair for a given connection request is stored in a queue in block 1402. When the stored inlet/outlet pair is to be processed, a conversion of the inlet and outlet numbers is made in block 1404 to the corresponding inlet and outlet numbers of the shuffle network topologically equivalent to network 1200. Then in block 1406 a disjoint path check is made using procedures described further herein to determine whether any of the possible paths  
10 for this connection request intersect with any of the possible paths for other connection requests being processed concurrently. If there is no conflict with other connection requests in progress, execution proceeds to block 1408 where the switches or links associated with all paths from the inlet to the outlet of the equivalent shuffle network are determined. Since, in network 1200, the switches (or nodes) are full capacity switches, it is sufficient to determine the links of a given path through the network. If the network  
15 switches are capacity one switches, it is sufficient to determine the switches of a given path through the network. Once the path components of all paths have been determined, an idle path is identified in block 1410 if such idle path exists. When an idle path is found, a path memory is updated in block 1412 to define the idle path using the inlet, outlet, and path numbers for the equivalent shuffle network. Connection orders are sent in block 1414 to the network stage controllers 1201 through 1209. Further, the path components  
20 (switches or links) for the identified path are marked busy in block 1416 for all stages.

Returning to block 1406, if it is determined that the given connection request is in conflict with other connection requests being processed, information concerning the given connection request is stored in a queue in block 1420. Once an idle path is found in block 1410 for one of the other connection requests, a report is made to the queue of block 1420. The disjoint path check of block 1406 is then repeated. If no idle  
25 path is identified in block 1410 for a connection request, blocks 1422 and 1424 are executed. In block 1422, a report is made to the queue of block 1420 that connection processing is completed. In block 1424, a blocking failure report is made to the queue of block 1402 such that the unsuccessful connection request can be processed again later.

Disconnection processing (FIG. 40) begins when a network 1200 inlet for a given disconnection request  
30 is stored in a queue in block 1440. When the stored inlet is to be processed, a conversion of the inlet number is made in block 1442 to the corresponding inlet number of the shuffle network topologically equivalent to network 1200. In block 1444, the shuffle inlet number is used to index the path memory to determine the shuffle outlet number and the path number for the connection. Disconnect orders are sent in block 1448 to the network stage controllers 1201 through 1209. Further, the path components (switches or  
35 links) for the path being disconnected are again marked idle for all stages.

A hardware embodiment of network controller 1300 is shown in FIGS. 42-44. Connection requests, specifying a particular network 1200 inlet/outlet pair, are stored in a connect request queue 1302. The nine-bit binary crossover inlet number and the nine-bit binary crossover outlet number are transmitted to a crossover to shuffle mapping unit 1304 (FIG. 50) for conversion to the corresponding nine-bit shuffle inlet  
40 number and the corresponding nine-bit shuffle outlet number. The shuffle inlet and outlet numbers are stored in a connect/disconnect request queue 1305 and then transmitted to a disjoint path check unit 1306 (FIG. 46). Unit 1306 determines whether the present inlet/outlet number pair defines paths through network 1200 which are link disjoint from the paths associated with another inlet/outlet number pair. When two or  
45 more connection requests define disjoint paths through network 1200, multiple connection requests and path hunts can be processed at the same time in what is referred to herein as an overlap mode of operation. The shuffle inlet/outlet numbers are then stored in a connect/disconnect request queue 1308. When a path hunt is to be performed, connect request queue 1308 transmits a read request signal to a plurality of memories 1312 that store the link busy/idle bits for a corresponding one of the link stages 4 through 11 of network 1200. (Link stage  $i$  is the stage of links between node stage  $i$  and node stage  $i+1$ .)  
50 The nine-bit shuffle inlet and the nine-bit shuffle outlet signals are also transmitted in parallel from connect request queue 1308 and predetermined ones of the inlet and outlet signals are used to address locations of the memories 1312.

Note that in network 1200 there are eight paths associated with any specified inlet/outlet pair. Each memory 1312 has 512 locations, each comprising eight bits. Each of the 512 locations of a given memory  
55 1312 corresponds to a different value of the predetermined nine bits extracted from the binary number formed by concatenating the inlet number, path number, and outlet number in the manner of FIG. 30. However, none of the path number bits are extracted for any of the stages. As a result, a memory 1312 location defines the busy/idle status of a link stage for each of the eight paths associated with a given

inlet/outlet number pair. All eight bits of the addressed memory 1312 locations are read and concurrently combined by a plurality of path busy/idle check units 1314, implemented, for example, as multi-input OR-gates. One of the path check units 1314 transmits an idle signal when all of its input signals indicate an idle status of links. An idle path select unit 1316 (FIG. 51) receives the busy/idle signals from each of the units 1314 and selects in a predetermined fashion one of the defined idle paths. Idle path select unit 1316 then transmits the binary number corresponding to the one of the eight paths selected. Unit 1316 also transmits a blocked path indicator if, in fact, there is no path found. The blocked path indicator is fed back to the connect request queue 1302 such that the connection request can be repeated at a later time. The inverse of the blocked path indicator is used as a write request signal to write a busy bit into each of the memories 1312. The idle path number is transmitted to the memories 1312 to additionally identify the particular path and therefore the particular bit of the location addressed by the inlet and outlet numbers. In addition, a path memory 1318 is updated in response to the write request and stores, at an address defined by the shuffle inlet, both the shuffle outlet and the selected idle path number.

A disconnect request queue 1320 effects disconnections by transmitting the crossover inlet to be disconnected, to crossover to shuffle mapping unit 1304 for conversion to the corresponding shuffle inlet. The shuffle inlet is then used to address path memory 1318. Disconnect request queue 1320 transmits a read request signal to path memory 1318 and reads the shuffle outlet stored at the location of path memory 1318 defined by the shuffle inlet address. The read shuffle outlet is then transmitted along with the shuffle inlet via queue 1305, disjoint path check unit 1306 and queue 1308 to address memories 1312. The addressed path memory 1318 location also includes the path number of the path to be disconnect. The read path number is transmitted in parallel to each of the memories 1312 to additionally specify the particular bit to be returned to an idle status. Thereafter, disconnect request queue 1320 transmits a write request which effects the change to idle status in the memories 1312 and also deletes information concerning that connection from path memory 1318. Each of the node stage controllers 1201 through 1209 includes a translator which effects a predetermined combination of the shuffle inlet, outlet, and path signals to determine both the node and the node input to node output connection to be enabled as part of a new path or to be disabled for a disconnection. The design of these translators is based on the following logic. Following reasoning similar to that to determine  $S_i(x, P^*, y)$  and  $L_i(x, P^*, y)$  from a binary representation of  $xM_1 + P^*M + y$ , we may determine  $I_i(x, P^*, y)$  (the input used on  $S_i(x, P^*, y)$ ) and  $O_i(x, P^*, y)$  (the output used on  $S_i(x, P^*, y)$ ).

$$I_i(x, P^*, y) = \left\lfloor \frac{xM_1 + P^*M + y}{r_i M_i} \right\rfloor_{m_i}$$

For  $2 \leq i \leq S-1$ ,  $r_i = 2^{n+k-1}$ ,  $M_i = 2^{S-i}$  and  $n_i = 2^i$ ,  $I_i(x, P^*, y)$  is given by a window of one bit displaced  $n+k-1+S-i$  bits from the right of the binary representation of  $xM_1 + P^*M + y$ .

$$O_i(x, P^*, y) = \left\lfloor \frac{xM_1 + P^*M + y}{M_{i+1}} \right\rfloor_{\text{mod } m_i}$$

$O_i(x, P^*, y)$  is then given by a window of one bit displaced  $S-i-1$  bits from the right of the binary representation of  $xM_1 + P^*M + y$ .

To map  $S_i(x, P^*, y)$ ,  $I_i(x, P^*, y)$ , and  $O_i(x, P^*, y)$  from the shuffle domain to the crossover domain we employ expressions (3) and (4) in Table 1 and expression (12a) in Table 3, respectively. The required exclusive-OR functions are easily implemented in hardware and the inputs to these actions are obtained directly from the binary representation of  $xM_1 + P^*M + y$ .

The crossover to shuffle mapping unit 1304 (FIG. 50) comprises a set of exclusive-OR gates combining the appropriate inlet and outlet signals. Since the network has fan-out and fan-in of eight, we may interpret the entire network as being comprised of a total of fifteen stages--three stages for one to eight fan-out, nine stages for switching, and three stages for one to eight fan-in. The fan-out/fan-in is accomplished by selectively equipping only one of each eight inlet/outlets (one inlet/outlet on one of four switches). The selected 512 inlet and outlet switches are then mapped to the shuffle domain using expression (1), of Table 1. The resulting logic is indicated in FIG. 50.

The memories 1312 are each 512x8 random access memories storing the link busy/idle bits. The path busy/idle check units 1314 are implemented as OR gates. The select unit 1316 (FIG. 51) is implemented using an arrangement of AND, NAND, OR, and NOR gates to define, using three path signals, the selected idle path, and to generate a single signal for use both as a blocked path indicator and as a write request signal.

The disjoint path check unit 1306 is based on the logic arrangement shown in FIG. 46. The two inlet/outlet pairs checked are designated as (X9, X8, X7, X6, X5, X4, X3, X2, X1) - (Y9, Y8, Y7, Y6, Y5, Y4, Y3, Y2, Y1) and (x9, x8, x7, x6, x5, x4, x3, x2, x1) - (y9, y8, y7, y6, y5, y4, y3, y2, y1). The logic arrangement of unit 1306 is applicable for checking disjoint paths in network 1330, shown in FIG. 49, independent of the fanout as indicated by the first stage of elements being 1x2<sup>n</sup> elements and independent of the fanin as indicated by the last stage of elements being 2<sup>n</sup>x1 elements. The logic arrangement of unit 1306 generates a logic zero signal when all paths for the inlet/outlet pairs are not link disjoint and generates a logic one signal when all pairs are link disjoint. The explanation of this logic is as follows. Consider the binary representation of xM<sub>i</sub> + P\*M + y for the two inlet/outlet pairs being checked.

$$\begin{array}{c} \overbrace{x_9 x_8 x_7 x_6 x_5 x_4 x_3 x_2 x_1}^x \text{ ppp } \overbrace{y_9 y_8 y_7 y_6 y_5 y_4 y_3 y_2 y_1}^y \\ \overbrace{x_9 x_8 x_7 x_6 x_5 x_4 x_3 x_2 x_1}^{x'} \text{ ppp } \overbrace{y_9 y_8 y_7 y_6 y_5 y_4 y_3 y_2 y_1}^{y'} \end{array}$$

L<sub>i</sub>(x,P\*,y) is given by a window of log<sub>2</sub> (r<sub>i</sub>m<sub>i</sub>) = n+k = 9+3 = 12 bits displaced by log<sub>2</sub> M<sub>i+1</sub> = 12-i bits from the right of these binary values for 4 ≤ i ≤ 11. Since any stage 1, 2, or 3 link is accessible by only one inlet (the three stages of fan-out) and any stage 12, 13, or 14 link is accessible by only one outlet (the three stages of fanin) we are concerned with L<sub>i</sub> only for 4 ≤ i ≤ 11.

Consider L<sub>4</sub>(x,P\*,y) and L<sub>4</sub>(x',P\*,y').

$$L_4(x,P^*,y) = X_8 X_7 X_6 X_5 X_4 X_3 X_2 X_1 \text{ ppp } Y_9$$

$$L_4(x',P^*,y') = x_8 x_7 x_6 x_5 x_4 x_3 x_2 x_1 \text{ ppp } y_9$$

Since the ppp field can take on all possible eight values, these two sets of links will be disjoint only if the remaining bits differ in at least one position. Thus, these two link sets will be disjoint if

$$D_4 = (X_8 \oplus x_8) + (X_7 \oplus x_7) + \dots + (X_1 \oplus x_1) + (Y_9 \oplus y_9) = 1. \text{ Similarly,}$$

L<sub>5</sub>(x,P\*,y) will be disjoint from L<sub>5</sub>(x',P\*,y') if

$$D_5 = (X_7 \oplus x_7) + \dots + (X_1 \oplus x_1) + (Y_9 \oplus y_9) + (Y_8 \oplus y_8) = 1 \text{ and soon until we reach } D_{11} = (X_1 \oplus x_1) + (Y_9 \oplus y_9) + \dots + (Y_2 \oplus y_2) = 1. \text{ The entire set of links will disjoint only if each } D_i = 1 \text{ or } D_T = D_4 \times D_5 \times \dots \times D_{11} = 1. \text{ The logic shown in FIG. 46 is a Boolean reduction of } D_T.$$

When two inlet/outlet pairs are determined to be link disjoint, then the path hunt function to establish connections can be performed in an overlap mode of operation, as shown in the timing diagram of FIG. 47. As shown, the times needed to perform a read of the memories 1312, the subsequent operation of the logic circuitry comprising OR gates 1314 and idle path select unit 1316, and then the subsequent time for writing of path memory 1318, as well as writing busy bits into the memories 1312, are indicated in FIG. 47 by the times R<sub>1</sub>, L<sub>1</sub>, W<sub>1</sub>. The corresponding times for a second connection request are designated R<sub>2</sub>, L<sub>2</sub>, W<sub>2</sub>. As shown, the second read occurs during the time that the results of the first reading are propagating through the several levels of logic gates. As shown in FIG. 48, when duplicate copies of the network controller memories, etc., are used, as in FIG. 45, four reads can be effected before the corresponding four writes occur.

Alternatively, instead of checking whether there are any conflicts among the paths between a first inlet and first outlet, and a second inlet and second outlet, one can simply proceed as if the selected paths did not conflict, and in case of a conflict, choose an alternate path between the second inlet and outlet. The presence of a conflict is detected if any of the busy-idle indicators for the second selected path are marked busy; in that case, the busy-idle indicators for that second path must be retained as idle, except for those detected to be already busy, and a hunt for an alternate path between the second inlet and outlet is made.

In many EGS networks, the probability that two connection requests are disjoint is high. Consider an EGS network with N inlets and M outlets, S stages, and with n<sub>i</sub> inlets on each switch in stage i and m<sub>i</sub> outlets on each switch in stage i and where

$$N \equiv 0_{\text{mod}} \prod_{j=1}^i n_j \text{ for } \prod_{j=1}^i n_j \leq N$$

$$\text{and } M \equiv 0_{\text{mod}} \prod_{j=1}^s m_j \text{ for } \prod_{j=1}^s m_j \leq M.$$

5

Define  $L(a,b)$  as the set of all links in all paths between inlet  $a$  and outlet  $b$ ,  $S(a,b)$  as the set of all switches in all paths between inlet  $a$  and outlet  $b$ , and  $\phi$  as the empty or null set. With these definitions, we state the following theorems.

10

Link disjoint path theorem:

$$L(x,y) \cap L(x',y') = \phi \text{ if and only if } t \geq u,$$

15

Switch disjoint path theorem:

$$S(x,y) \cap S(x',y') = \phi \text{ if and only if } t > u,$$

where

20

$t$  is the smallest value of  $i$  for which

$$x \equiv x'_{\text{mod}} \left[ \frac{N}{\prod_{j=1}^i n_j} \right]$$

25

and

$u$  is the largest value of  $i$  for which

30

$$\left[ \frac{Y}{\prod_{j=1}^s m_j} \right] = \left[ \frac{Y'}{\prod_{j=1}^s m_j} \right]$$

35

and where

40

$\lfloor W \rfloor$  denotes the largest integer  $\leq W$

and

$\lceil W \rceil$  denotes the smallest integer  $\geq W$ .

For  $x,y$  and  $x',y'$  chosen at random, we consider two cases:

Case 0:

45

$x$  and  $x'$  are chosen with replacement from the set of  $N$  inlets, i.e.,  $x$  and  $x'$  are allowed to be the same inlet. Similarly,  $y$  and  $y'$  are chosen with replacement from the set of  $M$  outlets. For this case we set a variable  $\beta = 0$ .

Case 1:

50

$x$  and  $x'$  and also  $y$  and  $y'$  are chosen without replacement from the sets of  $N$  inlets and  $M$  outlets, respectively. Thus,  $x \neq x'$ , and  $y \neq y'$ . For this case we set  $\beta = 1$ .

Link disjoint path probability:

The probability that  $L(x,y) \cap L(x',y') = \phi$  is given by

55

$$1 - \frac{(n_1 - \beta) \times \min \left( \prod_{j=2}^S m_j - \beta, N - \beta \right)}{(N - \beta)^2} + \frac{\sum_{i=2}^{S-1} \left[ \min \left( \prod_{j=1}^i n_j, N \right) - \min \left( \prod_{j=1}^{i-1} n_j, N \right) \right] \left[ \min \left( \prod_{j=i+1}^S m_j - \beta, N - \beta \right) \right]}{(N - \beta)^2}$$

Switch disjoint path probability:

The probability that  $S(x,y) \cap S(x',y') = \phi$  is given by

$$1 - \frac{(n_1 - \beta) \times \min \left( \prod_{j=1}^S m_j - \beta, N - \beta \right)}{(N - \beta)^2} + \frac{\sum_{i=2}^S \left[ \min \left( \prod_{j=1}^i n_j, N \right) - \min \left( \prod_{j=1}^{i-1} n_j, N \right) \right] \left[ \min \left( \prod_{j=i}^S m_j - \beta, N - \beta \right) \right]}{(N - \beta)^2}$$

For  $\log_2 N \leq S \leq 2 \log_2 N$ :  $P(\text{disjoint}) = P(\text{all paths between a given inlet/outlet pair are switch and link disjoint from all paths between another inlet/outlet pair}) =$

$$1 - \frac{2^S (2 \log_2 N - S + 1) - 2N + 1}{(N - 1)^2}$$

There are

$$\frac{N^2}{2} \left[ 2^S (2 \log_2 N - S + 1) - 2N + 1 \right]$$

ways to select two inlet/outlet pairs that have common switches for some paths. There are

$$N^2 \frac{(N - 1)^2}{2}$$

ways to select two inlet/outlet pairs. By way of example, for  $N = 512$ ,  $S = 9$ , there are

$$\frac{512^2}{2} [512(18 - 9 + 1) - 1024 + 1] = 537,001,984$$

ways to select two inlet/outlet pairs with intersecting paths and

$$\frac{512^2 \times 511^2}{2} = 34,225,651,712$$

ways to select two inlet/outlet pairs.

$$P(\text{disjoint}) = 1 - \frac{537,001,984}{34,225,651,712} = .9843.$$

In addition,  $P(\text{at least 2 of 3 pairs are disjoint}) \approx .99999613$ ,  $P(\text{each of 4 pairs are disjoint from the other three}) \approx .9094$ , and  $P(\text{some 4 of 5 pairs are all disjoint}) \approx .996$ .

## 10 Photonic System 10

For the present description of photonic system 10 (FIG. 1), only N-input, N-output networks including a fanout section (expansion), a switching section and a fanin section (concentration) (FIG. 2) are considered. Every node stage in the switching section has  $NF/2$  two-input two-output switching nodes. The fanout section multiplies each of the N inputs to F links at the input of the switching section. Accordingly there are FN links entering the switching section. The switching section contains S node stages with each node stage interconnected to the preceding node stage and the succeeding node stage with perfect shuffle equivalent interconnections. The fanin section groups together sets of F links and connects each group of F links to a different one of the N outputs.

Crossover interconnections are topologically equivalent to perfect shuffle interconnections. FIGS. 52 and 53 show two different two-dimensional implementations of a network with  $N=4$ ,  $F=2$ , and  $S=4$ . Network 2101 (FIG. 52) uses crossover interconnections and network 2102 (FIG. 53) uses shuffle interconnections. Note that the nodes in the two-dimensional crossover network 2101 are renumbered such that network 2101 has the same node connectivity as the two-dimensional shuffle network 2102. Also note that the shuffle interconnections are invariant from link-stage to link-stage, while the crossover interconnections vary from link-stage to link-stage.

A three-dimensional crossover network 2110 (FIGS. 55-57) is topologically equivalent to the two-dimensional crossover network 1170 of FIGS. 34-36. In network 1170, note that each node of a given node stage is labeled with a number from 0 through 31. Since network 1170 is a half-crossover network, it includes both crossover connections and straight connections. If the node numbers 0 through 31 are represented as the binary addresses 00000 through 11111, the crossover connections are such that a node in one stage is connected to the node in the next stage having a binary address differing in each of the p low order bit positions, where p is a positive integer at most equal to five. Thus node 0 (00000) in stage 0 is connected to node 1 (00001) in stage 1, node 0 (00000) in stage 1 is connected to node 3 (00011) in stage 2, node 0 (00000) in stage 2 is connected to node 7 (00111) in stage 3, node 0 (00000) in stage 3 is connected to node 15 (01111) in stage 4, node 0 (00000) in stage 4 is connected to node 31 (11111) in stage 5, node 0 (00000) in stage 5 is connected to node 1 (00001) in stage 6, node 0 (00000) in stage 6 is connected to node 3 (00011) in stage 7, and node 0 (00000) in stage 7 is connected to node 7 (00111) in stage 8. For the straight connections, each node in one stage is connected to the node in the next stage having the same binary address. Note that the three-dimensional crossover network 2110 (FIGS. 55-57) achieves the same node connectivity as two-dimensional crossover network 1170 (FIGS. 34-36) when the node numbers 0 through 31 are associated with successive nodes of rows and in opposite direction across successive rows in serpentine fashion. Also note that certain stages are interconnected with only horizontal connections (only nodes in the same row are interconnected) and the other stages are interconnected with only vertical connections (only nodes in the same column are interconnected). More generally, if a network is made up of two-dimensional arrays of nodes each array having C columns and R rows, the crossover connections are defined as follows: when the binary addresses corresponding to the integers from zero through  $RC-1$  are respectively associated with successive nodes of rows and in opposite directions across successive rows in serpentine fashion, each node in one array is connected to the node in the successive array having a binary address differing in each of the p low order bit positions, p being a positive integer at most equal to  $\log_2(RC)$ .

Photonic system 10 includes stages of two-input, two-output switching nodes within the fanout section and fanin section as well as within the switching section. Network 2112 (FIG. 59) is an example of a crossover network of this type. Unused nodes and links are indicated by dashed lines in FIG. 59. Since each stage in the fanout section results in a fanout of two,  $\log_2 F$  stages are required to achieve a fanout of F. Similarly,  $\log_2 F$  stages are required for a fanin of F. Thus, the total number (T) of node-stages in a network, with S stages in the switching section and having fanout and fanin dual to F, is given by:  $T = S + 2\log_2 F$ . Since network 2112 has the parameters  $N=4$ ,  $F=4$ , and  $S=2$ , the total number of node-stages is

six.

Recall that a  $n \times m$ -module is a node that broadcasts the logical union of its  $n$  inputs to all of its  $m$  outputs. Photonic system 10 is implemented using 2-modules as the switching nodes (unlike network 1170 of FIGS. 34-36 which was assumed to have full capacity nodes). System 10 is controlled such that any given 2-module has only one active input at any time. Several electronic implementations of 2-modules are described herein along with optical counterparts.

One electronic 2-module implementation is based on a tri-state buffer 2120 (FIG. 60). The truth table of FIG. 61 defines the operation of a tri-state buffer. If the tri-state control input is low (0), the output is a regenerated version of the active input signal. If the tri-state control input is high (1), the output is tri-stated and appears as a high impedance. Since the tri-state buffer accepts only one active input signal from the signals that are connected in wire-OR fashion at the input, at least one of the input signals must be disabled or tri-stated by the previous stage.

An optical device 2125 (FIG. 63) similar to an inverting tri-state buffer 2122 (FIG. 62) can be used to implement an optical 2-module. The device is a three-diode M-SEED, also referred to as an enabled S-SEED. M-SEEDs ( $M=3$ ), which are described in U. S. Patent 4,800,262 issued to A. L. Lentine on January 24, 1989, have quantum-well diodes electrically connected in series (FIG. 63) and operate as defined by the truth table of FIG. 64. Assume that a binary one is encoded as the presence of optical power and a binary zero is encoded as the absence of optical power, i.e., less than a predefined threshold. In FIG. 63, the three diodes are labeled S (set), R (reset), and E (enable). The truth table defines that the S and R diodes operate as an S-R flip-flop when the E diode has optical power directed at it. When the E diode has no optical power (less than the predefined threshold) directed at it, no optical power is transmitted from the S or R outputs when the clock or power signals are directed at the three diodes.

The operation of an M-SEED is similar to that of a tri-state buffer. Throughout the present description, it is assumed that the top rail of the figures is the positive rail and the bottom rails the negative rail. As a result, a binary one is encoded as the presence of optical power on the top (positive) rail and the absence of optical power on the bottom (negative) rail. The S-R flip-flop operates as an inverting buffer. Data streams are transmitted through the S-R flip-flop using a two-phase approach where a bit is stored during the first half of a bit period and transmitted to the next stage during the second half of the bit period. Each bit period includes a write cycle followed by a read cycle. The clock or power signal is directed at all three diodes of the M-SEED during the read cycle. The directed signals are modulated by the M-SEED and the resulting output signals represent the complement of the bit that was stored during the previous cycle. Data is complemented when it is transmitted through an M-SEED since the Q output is associated with the R input of the S-R flip-flop. A binary one entering the S-R flip-flop resets the device and is transmitted (when the S-R flip-flop is clocked) as a binary zero. M-SEED 2125 (FIG. 63) performs the function of inverting buffer 2122 (FIG. 62). Since data transmitted through multiple stages of inverting buffers is successively complemented, the complementation has no effect for an even number of stages. If there is an odd number of stages, one additional complementation may be effected at the output.

A second electronic 2-module 2130 is shown in FIG. 65. The corresponding truth table is given in FIG. 66. In 2-module 2130, the two input signals are combined by an OR gate. The output of the OR gate is transmitted to an AND gate where the enable control signal is combined with the data signal. If the enable control signal is high (1), the data is transmitted to the two outputs. If the enable control signal is low (0), the 2-module is disabled and the outputs are held at logic zero. One of the two inputs to the OR-gate must be disabled by the 2-modules of the previous stage since the data would otherwise be combined and corrupted at the output of the OR-gate. Electronic 2-module 2130 generates a logic zero at the disabled output instead of the high impedance that is generated at the disabled output of the tri-state buffer. Thus, the technique of wire-ORing the two inputs of the 2-module is not used; a logic OR-gate is required.

Some variations of OR/AND logic are used to implement 2-modules in the optical domain. In the present embodiment of photonic system 10, two types of 2-modules are used to implement a three-dimensional network. Instead of using the OR/AND implementation of FIG. 65, NOR/OR implementation 2132 (FIG. 67) and NAND/AND implementation 2136 (FIG. 70) are used as the bases of the two types of 2-modules.

NOR/OR implementation 2132 (FIG. 67) combines the two data inputs at a NOR gate, complementing the sense of the incoming data as it is transmitted through the NOR gate. The complemented data is transmitted to an OR gate, where it is combined with the disable control signal. When the disable control signal is low (0), the complemented data is transmitted to the two outputs. When the disable control signal is high (1), the 2-module is disabled and the outputs are held at logic one. One of the two NOR gate inputs must be a disabled logic zero signal from the 2-module in the previous stage. Since the NOR/OR 2-module implementation generates a logic one at its disabled output, a second type of 2-module is required that

generates a logic zero at its disabled output.

NAND/AND implementation 2136 (FIG. 70) combines the two data inputs at a NAND gate, complementing the sense of the incoming data as it is transmitted through the NAND gate. The complemented data is transmitted to an AND gate, where it is combined with the complement of the disable control signal. When the disable control signal is low (0), the complemented data is transmitted to the two outputs. When the disable control signal is high (1), the 2-module is disabled and the outputs are held at logic zero. One of the two NAND gate inputs must be a disabled logic one signal from the 2-module in the previous stage.

If no complementing of data occurs within the interconnections, the NOR/OR 2-module may be used in stages preceding stages with NAND/AND 2-modules and the NAND/AND 2-module may be used in stages preceding those with NOR/OR 2-modules. A system including alternating stages of NOR/OR 2-modules and NAND/AND 2-modules would satisfy the requirements on the disabled signals for both of the 2-module implementations.

A symmetric self electro-optic effect device (S-SEED), described in U. S. Patent 4,754,132 issued to H. S. Hinton et al., on June 28, 1988, is used to provide the functionality of both types of 2-modules. When a bit stream is transmitted through an S-SEED logic gate, three functions are performed in time sequence during each bit period. During a first, preset period, the S-SEED is forced into a known state such that its output  $Q(t)$  is a known binary value. During a second, write period, the dual-rail input data is used to write the new state of the S-SEED. Assume that the S-SEED windows are vertically oriented with the top window referred to as the R (reset) input and the bottom window as the S (set) input (FIGS. 68 and 71). The output from the top window is referred to as the Q output and the output from the bottom window is referred to as the  $\bar{Q}$  output. The S-SEED is a ratio device that changes state when the ratio of the power entering one optical window to the power entering the other optical window exceeds a predefined threshold  $T$ . If the power entering the S window is  $P_S$  and the power entering the R window is  $P_R$ , the S-SEED is set ( $Q[t+1] = 1$ ) if  $P_S/P_R > T$ . The S-SEED is reset ( $Q[t+1] = 0$ ) if  $P_R/P_S > T$ . During a third, read period, the new state of the S-SEED is read out and transmitted to the next stage. By applying a high-powered clock or power signal of equal intensity to both the R and S inputs, the clock signal is modulated and reflected from the windows with two unequal intensities that represent the dual-rail information presently stored in the S-SEED. The Q output power exceeds the  $\bar{Q}$  output power when the S-SEED is set; the  $\bar{Q}$  output power exceeds the Q output power when the S-SEED is reset. An S-SEED array 500 shown in FIG. 58 is used to implement each of the node stages of network 2110 (FIGS. 55-57) and photonic system 10 (FIG. 1). Although in the present example and for purposes of illustration, array 500 is a 4 x 8 rectangular, S-SEED array, such arrays are typically implemented such that the photodetector array is a square array.

The preset, write, and read period durations are determined by the pulse rate of the laser diodes that generate the clock or power signal, the preset signal, and the disable signal (a continuous disable signal may also be used). Timing control of the electronic clock signals which drive laser diodes 301, 401 and 451 is provided by the circuit of FIG. 73. The output pulse of a one-shot 452 of FIG. 73 has a duration  $T_{shot}$ , which is typically less than one-fourth of a bit period, and is synchronized to the data bit stream. The circuit of FIG. 74 may be used to drive the lasers in, for example, three stages of the system if appropriate delay lines (not shown) are added to the electronic signal paths to account for the optical propagation delays between stages. FIG. 75 is a typical timing diagram for the three stages. In FIG. 75, it is assumed that the input data is formatted using a return-to-zero format and that the serial bits arriving at the input are labeled in alphabetical order A, B, C, D, and E. During the first half of each bit period, data is written into the odd-numbered S-SEED arrays and read out from the even-numbered S-SEED arrays. During the second half of each bit period, data is written into the even-numbered S-SEED arrays and read out from the odd-numbered S-SEED arrays. Thus, the data is transmitted from stage to stage within the network in the pipelined fashion of a shift register of master-slave flip-flops. The odd-numbered S-SEED arrays perform as the master flip-flops and the even-numbered S-SEED arrays perform as the slave flip-flops.

Data is written into S-SEED array  $i$  during the interval when both the clock signal and the preset signal directed at array  $i$  are low (off). Data from the previous stage ( $i-1$ ) is transmitted to array  $i$  during this interval. The clock in S-SEED array ( $i-1$ ) is set high (on) when the clock in S-SEED array  $i$  is low (off). This permits S-SEED array  $i$  to receive data and preset signals at the same time. The preset signals have sufficient optical power to overcome any effects of the low optical power data signals. The duration of the pulses generated by one-shot 452 defines the length of the write period. In particular, if the duration of the incoming bit period is  $T_{bit}$  and the one-shot period is  $T_{shot}$ , the read period for the S-SEED array is  $T_{bit}/2$  and the write period is  $T_{bit}/2 - T_{shot}$ . The differential power arriving as data at each S-SEED must be sufficient to set the state of the S-SEED within the write period.

The function of 2-module 2132 (FIG. 67) is performed by an S-SEED 2134 having signals directed at it as shown in FIG. 68. The truth table for the optical 2-module comprising S-SEED 2134 is given in FIG. 69. It

is assumed that the state of the S-SEED is initially set to  $Q[t]=0$  by pulsing the R input during the preset period. The columns labeled P(S) and P(R) indicate the power entering each of the S-SEED windows during the write period. As indicated

$P(S) = P(\ln 0) + P(\ln 1) + P(\text{Disable})$  and  $P(R) = P(\ln 0) + P(\ln 1)$ . For purposes of explanation, typical power values are assumed. An active signal on any of the data inputs  $\ln 0$ ,  $\ln 1$ ,  $\ln 0$ ,  $\ln 1$ , contributes 3.0 power units, while the inactive signals each contribute 1.0 power unit. Thus, the contrast ratio of the S-SEED in the previous stage is 3:1. When the disable signal is activated, it contributes 7.1 power units; when it is not activated, it contributes 0.071 power units. Thus, the spatial light modulator that controls the disable signal is assumed to have a contrast ratio of 100:1. The S-SEED ratio threshold T is assumed to be equal to 1.5. Thus, if the ratio  $P(S)/P(R)$  is greater than 1.5, the output is set,  $Q[t+1]=1$ . If the ratio  $P(R)/P(S)$  is greater than 1.5, the output is reset,  $Q[t+1]=0$ . If the ratio  $P(S)/P(R)$  is between 0.667 and 1.5, the output does not change; therefore  $Q[t+1]=Q[t]=0$ , the preset output state. The outputs read during the read period are given in the last column of the truth table of FIG. 69.

The function of 2-module 2136 (FIG. 70) is performed by S-SEED 2138 having signals directed at it as shown in FIG. 71. The truth table for the optical 2-module comprising S-SEED 2138 is given in FIG. 72. The implementation of FIG. 71 is very similar to the implementation of FIG. 68 except that the disable signal has been moved from the S input to the R input, and the preset signal has been moved from the R input to the S input. The state of the S-SEED is initially set to  $Q[t]=1$  by pulsing the S input during the preset period. With the same assumptions about power levels, the outputs read during the read period are given in the last column of the truth table of FIG. 72.

Two basic approaches have been described for 2-module optical implementations--one using three-diode M-SEEDs and the other using two-diode S-SEEDs. The M-SEED approach has an advantage in that it only requires two lasers (one for the clock or power signals and one for the enable signals) whereas the S-SEED approach uses three lasers (one for the clock or power signals, one for the disable signals and one for the preset signals). However, the M-SEED approach requires three diodes rather than two; accordingly, the system optics must image larger fields when the M-SEED approach is followed. The S-SEED approach is used in photonic system 10 of FIG. 1.

The relationship between the orientation of the S-SEED and the orientation of the plane containing the crossing links in a crossover connection has an impact on the design of the overall network. This relationship determines the types of 2-modules (NOR/OR or NAND/AND) that are used in particular stages of the network. Assume that the S-SEEDs are oriented vertically as shown in FIG. 58. The horizontal crossover connection is then defined to be a crossover connection where the crossing links form a plane that is perpendicular to the line formed by the S-SEED diodes. The vertical crossover connection is defined to be a crossover connection where the crossing links form a plane that is parallel to the line formed by the S-SEED diodes.

Optical hardware module 51 of FIGS. 1 and 93 is used to provide the horizontal crossing connections and the straight connections for horizontal crossover stages. The straight connections are provided by the planar mirror 108 and the horizontal crossing connections are provided by a prismatic mirror 105 or, if more than one cross is required, by a prismatic mirror array 110 (FIG. 84). Prismatic mirror array 110 has its V-grooves oriented in the vertical direction to provide horizontal shifts. The resulting horizontal crossover connections between two consecutive S-SEED arrays are shown in FIG. 76.

A modification of optical hardware module 51 of FIG. 93 is used to provide the vertical crossover stages. The prismatic mirror that provides the crossing connections is rotated by 90 degrees about the optical axis. For vertical crossover stages requiring multiple crosses, the prismatic mirror array is rotated by 90 degrees. As a result, the V-grooves of the prismatic mirror array are oriented horizontally to provide vertical shifts. The crossing connections within the vertical crossover stages also cross the data rails. Crossing the rails within a dual-rail system is equivalent to complementing the data bits. If the straight connections were implemented with a mirror as in FIG. 93, the data bits traveling along the straight connections would not be complemented. Since some of the bits within a link stage would be complemented and others would not, equipment at the output of the system would be required to determine which outgoing data streams have been complemented and which ones have not been complemented. This would require information about every path routed through the network. To avoid this problem, the data bits within the straight connections of the vertical crossover stages are also complemented by crossing the dual rails. This is accomplished by replacing mirror 108 of FIG. 93 by a prismatic mirror array with very narrow V-grooves. The width of these grooves matches the spacing between the S-diode and the R-diode and thus reverses the positions of the outputs of each S-SEED thereby inverting the dual-rail data. The resulting vertical crossover connections between two consecutive S-SEED arrays are shown in FIG. 77.

The 2-modules on either side of a horizontal crossover stage are designed differently than the 2-modules on either side of a vertical crossover stage. The sense of the disabled output data is controlled to ensure that the disabled data entering a NOR/OR 2-module is a logic one, while the disabled data entering a NAND/AND 2-module is a logic zero. In the previous description where only horizontal crossover stages were being considered, a network alternating between NOR/OR 2-modules and NAND/AND 2-modules provides the necessary disabled outputs. However, when vertical crossover stages are added to the network, the design rules are modified. Since all of the dual-rail data passing through a vertical crossover connection is complemented by the connection, the disabled output (logic one) of a NOR/OR 2-module is complemented by the vertical crossover and passed as a logic one directly into the input of a NOR/OR 2-module in the next stage. Similarly, the disabled output (logic zero) of a NAND/AND 2-module is complemented by the vertical crossover and passed as a logic zero directly into the input of a NAND/AND 2-module in the next stage. Thus, the 2-modules on either side of a vertical crossover stage should both be of the same type (NOR/OR or NAND/AND). The following five design rules may be applied: 1) the first node stage should use NOR/OR 2-modules so that there is no need to generate a set of logic one signals to replace the disabled inputs normally received from a previous stage, 2) any node stage that follows NOR/OR 2-modules in the previous node stage and a horizontal crossover in the previous link stage should use NAND/AND 2-modules, 3) any node stage that follows NOR/OR 2-modules in the previous node stage and a vertical crossover in the previous link stage should use NOR/OR 2-modules, 4) any node stage that follows NAND/AND 2-modules in the previous node stage and a horizontal crossover connection in the previous link stage should use NOR/OR 2-modules, and 5) any node stage that follows NAND/AND 2-modules in the previous node stage and a vertical crossover connection in the previous link stage should use NOR/OR 2-modules. These rules are based on the assumption that the S-SEED windows are oriented vertically. The rules require that 2-modules of different types are used on the two sides of a horizontal crossover stage and that 2-modules of the same type are used on the two sides of a vertical crossover stage. If the S-SEED windows were oriented horizontally, the design rules would change such that 2-modules of different types are used on the two sides of a vertical crossover stage and 2-modules of the same type are used on the two sides of a horizontal crossover stage.

If the five design rules are used to design a photonic system network, the data streams passed through the network are complemented many times as they are routed through the multi-stage network. Complementing occurs at every node stage due to the function of the NOR and NAND gates and complementing also occurs in vertical crossover link stages. All of the complementing operations must be accounted for in the overall network. If the data is complemented an odd number of times as it passes through the network, one more complementing function is added to correct the sense of the data. This additional complementing function may be provided, for example, by adding an extra stage of 2-modules, by adding an extra stage of connections that cross rails, by inverting the data in interface electronics at the network output or by alignment of the output fiber matrix with the appropriate S-SEED diode. As an example, consider network 2200 (FIG. 78) comprising nine node stages. A single path through the network is identified by bold links in FIG. 78. FIG. 79 shows a line of linked 2-modules comprising the 2-modules of the single path of FIG. 78 and the associated disabled 2-modules. The sense of the data at various points through the network is shown. The complementing in the vertical link stages is also shown. At the output of network 2200, the data is complemented. Accordingly, the data must be complemented one additional time at the output of the network to return to its initial form.

The routing techniques used for 2-module networks are different than those used, for example, for networks of full capacity switching nodes. Every 2-module receives data from two 2-modules in the previous node stage and sends data to two 2-modules in the next node stage as shown in FIG. 80. An active data path affects four 2-modules in any pair of consecutive node stages. Referring to FIG. 80, if 2-module A in node stage  $j$  is activated, the output data from 2-module A is directed to two 2-modules C and D in node stage  $j+1$ . For point-to-point operation, only one of the two 2-modules receiving data in node stage  $j+1$  is enabled to route the data to node stage  $j+2$ . The other 2-module in stage  $j+1$  is disabled. Assume that 2-module C is enabled and 2-module D is disabled. The other 2-module (B) in node stage  $j$  that is connected to 2-module D cannot pass data through 2-module D, even though 2-module D is not carrying an active data path. If 2-module D is enabled to carry data from 2-module B, the data arriving at the input of 2-module D from 2-module B is corrupted by the data also arriving at 2-module D from 2-module A. Thus 2-module D is corrupted by the active data path that routes data from 2-module A to 2-module C. Accordingly, 2-module B may not be used. In effect, a node within a 2-module based network exists in one of three states: 1) it may be busy carrying an active call, 2) it may be idle with no calls passing through it, or 3) it may be idle but corrupted by the presence of a call passing through another 2-module of the same stage. Thus, if a call is passed through a 2-module-based network with  $Y$  stages, it uses  $Y$  active 2-modules

(one per stage) to carry the call and it corrupts (Y-1) idle 2-modules (one per stage in all but the first node stage). There are also (Y-1) idle 2-modules that may not be used because they are only connected to an active 2-module and a corrupted 2-module in the next node stage.

A 2-module network is controlled such that at most one of the signals receivable from the preceding stage nodes is active at any time. Each node is associated with one other node of the same stage--the node that is coupled to receive signals from the same two nodes of the preceding stage. Busy/idle information is stored for each of the nodes of each of the stages. A given node of one of the stages is selected for use as part of a connection through the network only when both the given node and the node associated with the given node are marked idle. After the selection, the given node is marked busy.

### Free Space Optics

The following description relates to a combination of optical techniques which together satisfy the hardware requirements for the optical switching fabric of photonic system 10 (FIG. 1) using two-dimensional arrays of switching devices--in the present embodiment, S-SEEDs. As in electronic systems, the interconnection paths along which the data signals flow are only part of the total system. Each S-SEED array within photonic system 10 requires the following: 1) relaying the data input images onto the S-SEEDs, 2) relaying the power input images onto the S-SEEDs, 3) relaying the control input images onto the S-SEEDs, 4) data connections (crossover alignment network), 5) beam combination for data, power and control inputs, and 6) data outputs to the next stage. These requirements are substantially the same for each S-SEED array; accordingly the optical hardware modules used to meet the requirements for each stage have few variations.

FIG. 81 is a functional block diagram of a portion of photonic system 10. The data signals on the input fibers are conditioned and spatially aligned by the data input unit 40. The crossover interconnections required for the various stages are provided by the optical crossover interconnection unit 100. Arrays of spots which form the power and control inputs are generated by the power and control units 300 and 400. All of the spot arrays (data or information signal, power or clock, and control) are combined into a single spot array to be imaged onto the S-SEED arrays 500. This combination is performed by the beam combination unit 200. The S-SEED array 500 selectively reflects the power signals and beam combination unit 200 redirects the reflected power signals as input data signals to the next stage. The functions are repeated for each stage until the last, where the data signals are imaged onto output fibers by a lens 70 (FIG. 1). It should be noted that further signal conditioning, e.g., demultiplexing/multiplexing, clock extraction, bit and frame alignment, error checking, regeneration, etc., will typically be required to interface the input and output fibers to transmission facilities.

The S-SEED arrays are interconnected in perfect shuffle equivalent fashion using optical crossover interconnect unit 100 shown in FIG. 82. As shown in network 1170 (FIGS. 34-36) the size of the cross varies from stage to stage, and in the three-dimensional crossover network 2110 (FIGS. 55-57), the direction of the cross also varies.

FIG. 82 shows the optical arrangement used to implement optical crossover interconnect 100. The input image (shown entering from the bottom in FIG. 82) is circularly polarized when it passes through lens 101 to polarization beam splitter (PBS) 102, where it is split into two copies. The copy passing through PBS 102 is linearly polarized (p-type) (parallel polarization) until it passes through quarter-wave plate (QWP) 106 and becomes circularly polarized. Lens 107 focuses it to a spot array on plane mirror 108. Reflecting off mirror 108, the image returns through QWP 106. After this second pass through QWP 106, the image is linearly polarized (s-type) (perpendicular polarization) and is reflected by PBS 102. The other image copy, initially reflected by PBS 102, follows a similar path through QWP 103 and lens 104, except that it is imaged onto a prismatic mirror (PM) 105. PM 105 reverses the image about the axis of its corner, as well as reflecting the image back toward lens 104. This reverted and reflected image is collected by lens 104 and passes again through QWP 103. The polarization of the reflected image is rotated and the image passes through PBS 102 on its return trip. At the output, the two image copies are recombined into a single, overlapped image. Thus the connection of FIG. 83 is formed, where the reversed image forms the crossed connections, and the other image, the straight connections. Once the QWPs 103 and 106 are properly oriented with their fast axes at 45 degrees to the plane of incidence of PBS 102, they may be cemented directly to PBS 102. The use of polarization and highly reflective components allows this interconnection to be implemented with very little loss.

As previously mentioned, the width of the cross is varied from stage to stage. One means of realizing this is by replacing the prismatic mirror 105 with a prismatic mirror array (PMA) 110 as in FIG 84. In this case, each prism facet reverses or crosses a portion of the image. Thus to vary the width of the cross, the

width of the facets is varied. Some system stages effect horizontal crossovers and the other stages effect vertical crossovers. The vertical crossovers are achieved by rotating the PMAs by 90 degrees so that the spot array images are reversed about horizontal, rather than vertical axes. The crossover connections which are parallel to the line joining the S and R diodes of the S-SEEDs are referred to as vertical crossovers and the connections perpendicular to this line are referred to as horizontal crossovers. The vertical crossovers not only interconnect the S-SEEDs but also invert the positions of the S and R diodes forming the S-SEEDs. This causes a data inversion within the vertical cross connections and thus requires that a similar data inversion be implemented for the companion straight connections. This is accomplished by replacing plane mirror 108 with a PMA with very narrow V-grooves. The width of these grooves matches the S-R diode spacing and thus reverses the positions of the S and R outputs of each S-SEED, thereby inverting the dual rail data. In all cases, the overall size, shape, and input/output interfaces of the optical crossover interconnect unit 100 remains the same, which significantly eases system integration.

In photonic system 10 (FIG. 1), note prismatic mirror 105 and plane mirror 108 in optical hardware module 51 which implements a horizontal crossover having a single cross. In optical hardware modules 50 and 55, prismatic mirror 105 is replaced by a prismatic mirror array having two V-grooves to implement a horizontal crossover having two crosses. In the optical hardware modules 52, 53, 54, and 57, which implement vertical crossovers, plane mirror 108 is replaced with a prismatic mirror array having narrow V-grooves to perform the data inversion necessary for vertical crossover stages. Also in optical hardware modules 52, 53, 54, and 57, the prismatic mirrors or prismatic mirror arrays are rotated by 90 degrees as required to effect vertical crossovers.

Since the S-SEEDs used in photonic system 10 form two-dimensional arrays, the data signals passed from one stage to the next take the form of two-dimensional arrays of spots. The power inputs, which effect the signal amplification, and the control inputs, which determine the mode of device operation and control the establishment of network paths, also have the form of two-dimensional spot arrays.

The optical arrangement shown in FIG. 85 is used to generate an array of uniform intensity spots of good contrast. A single laser beam generated by laser diode 301 is collimated by lens 302 and is incident upon gratings 303, which split the beam into many uniform intensity beams. These beams are focused by lens 304 into an array of spots in the focal plane of lens 304. Generally, the uniform spots occupy a central region of the plane and are surrounded by non-uniform, lower intensity spots. The unwanted, non-uniform spots are blocked out by spatial filter 305. The spots in the central region pass through spatial filter 305 and are recollimated by lens 306 to form an array of beams. This array is incident on the multiple-imaging gratings 307 which split the array into many uniform copies. When these copies are ultimately focused into spots on S-SEED array 500, many abutted copies of the original central region spot array are produced. A large uniform spot array is achieved by abutting many uniform copies of a small uniform spot array.

To generate the preset and disable spot arrays, optical arrangements similar to that of FIG. 85 are used but with the following differences. To allow low-loss combination of the signal, power, and control spot arrays, the control (preset and disable) spot arrays are forms having a lower wavelength (780 nanometers) than the nominal S-SEED operating wavelength (850 nanometers). The spots in the preset spot array are imaged onto only one diode of each S-SEED in the S-SEED arrays, rather than onto both diodes as the power spots are. Since fewer spots are formed per array, the spots may have more optical power than the spots of the power spot array if laser diodes having the same power output are used; alternatively, lower power laser diodes may be used for the preset beams.

The disable beams are incident only upon the disabled S-SEED 2-modules within each S-SEED array. To generate this space-variant spot array, a space-invariant spot array identical to the preset spot array (but shifted by one diode position) is generated and the spots are passed through an electrically-controlled spatial light modulator which blocks the spots corresponding to enabled devices. The remaining spots pass through the spatial light modulator and are imaged onto the S-SEEDs to be disabled.

The optical arrangement used to generate the disable spot array is shown in FIG. 86. The portion of the arrangement comprising laser diode 401, lens 402, gratings 403, lens 404, spatial filter 405, lens 406, and gratings 407 is substantially identical to the arrangement of FIG. 85. Lens 408 is placed immediately after gratings 407 to focus the beam array to a spot array on spatial light modulator 409. The spots which are passed by spatial light modulator 409 are recollimated into a space-variant beam array by lens 410. These beams are ultimately refocused onto S-SEED array 500. As the paths through the network are changed for new or completed calls, the configuration of spatial light modulator 409 changes to disable or enable different 2-modules.

Beam combination unit 200 (FIG. 81) combines two control beam arrays (preset and disable), a power beam array, and two signal beam arrays onto S-SEED array 500. Beam combination unit 200 also provides an output path for the output beam array that is reflected from S-SEED array 500. Power/speed tradeoffs for

the S-SEEDs dictate that the combination be done with as little loss as possible. The size of the S-SEEDs also affects their speed, so the S-SEEDs, and thus the spots, are quite small (1-10 microns). This dictates the use of beam combination techniques which preserve space-bandwidth product, ruling out pupil division. In the present embodiment, beam combination unit 200 comprises three sub-units 210, 240 and 270. Beam combination sub-unit 210 (FIG. 87) combines the preset and disable beam arrays into a control beam set. Beam combination sub-unit 240 (FIG. 88) combines this control beam set with the power beam array. Beam combination sub-unit 270 (FIG. 90) combines the power/control beam set with the two (overlapped) signal beam arrays, and provides a path for the output beam array. The relationship of the sub-units 210, 240, and 270 is shown in beam combination unit 200 of optical hardware module 51 in FIG. 93.

Beam combination sub-unit 210 (FIG. 87) uses a space-multiplexing technique to combine the preset and disable beam arrays. The generation of the disable beams is done such that they are linearly polarized (s-type) (perpendicular polarization) with respect to the plane of incidence of PBS 216. They are reflected by PBS 216 and pass through QWP 211 with its fast axis oriented at 45 degrees to the s-polarization. QWP 211 retards the component of the light perpendicular to the fast axis by one-quarter wavelength, such that resulting beams are circularly polarized. As they pass through lens 212, they are focused onto a patterned mirror reflector (PMR) 213. PMR 213 is an array of small mirrors deposited on a transparent substrate. The size of the mirrors matches the spot size and the mirrors are positioned such that the reflected spots are imaged by the rest of the beam combination optics onto one diode of each S-SEED. After the spots reflect off PMR 213, they are recollimated by lens 212 and pass through QWP 211 a second time. This second pass again retards the perpendicular component by another one-quarter wavelength, thus converting the beams to p-type (parallel) linear polarization and the beams pass through PBS 216.

The preset beam array generation is oriented such that the beams enter sub-unit 210 with p-type linear polarization. QWP 215 reads the polarization component perpendicular to its fast axis by one-quarter wavelength and converts the beams to circular polarization. Lens 214 focuses the beams to spots on transparent areas of PMR 213. These spots are positioned such that they are imaged onto the S-SEED diodes that do not have disable spots. The preset spots pass through PMR 213 and are recollimated by lens 212. QWP 211 is oriented with its fast axis at 90 degrees with respect to QWP 215. Thus QWP 211 retards the other polarization component (the one not retarded by QWP 215) by one-quarter wavelength and returns the beam array to its original p-type linear polarization. The preset beams pass through PBS 216. At the output, the two beam arrays are combined into the same aperture and onto the same polarization. Since the spots are imaged through a glass plate, spherical aberration can accumulate. If the plate is thin (approximately 1 mm) and lenses with focal lengths more than 30 mm are used, the spherical aberration is not significant. The depth of focus of the spot array image at PMR 213 is relatively large (greater than 16 microns), thus easing the alignment tolerances for PMR 213.

Beam combination sub-unit 240 (FIG. 88) combines the control beam array (preset and disable) with the power beam array. In sub-unit 240, a dichroic or wavelength-selective mirror (DM) 243 is used rather than a spatially-selective (space-variant) mirror. DM 243 reflects 850-nanometer light and transmits 780-nanometer light. Similar to the disable beams in sub-unit 210 (FIG. 87), the power beams enter sub-unit 240 (FIG. 88) with linear polarization of s-type, reflect off PBS 241 (designed for 850-nanometer operation) and DM 243, then pass through PBS 241 and exit having p-type linear polarization. The 780-nanometer control beams (preset and disable) transmitted from sub-unit 210 enter having p-type linear polarization and pass through QWP 244 designed for 850-nanometer operation. QWP 244 retards the polarization component perpendicular to its fast axis by greater than one-quarter wavelength, resulting in elliptical polarization. After passing through DM 243, QWP 242 is encountered. QWP 242 is oriented with its fast axis at 90 degrees with respect to QWP 244. QWP 242 causes an identical (greater than one-quarter wavelength) retardation of the other polarization, returning the beam array to p-type linear polarization such that it passes through PBS 241. At the output of sub-unit 240, the two beam sets of different wavelengths are combined into the same aperture and onto the same polarization.

It is significant that the two beam sets are combined onto the same polarization. It is difficult to separate the wavelength and polarization performance of optical elements, except near zero degrees incidence. In the next subunit 270 (FIG. 90), an 850-nanometer PBS 271 is used but it is necessary that the beams of the 780-nanometer control beam array pass through it, either in reflection or transmission. FIG. 89 is a plot of typical transmission curves for a PBS designed for 850-nanometer operation. For the thin film components used in polarization beam splitters, a variation in the angle of incidence corresponds to a variation in wavelength. The beam arrays used in the present embodiment may have a substantial angular field, for example, of plus or minus five degrees. To reflect linearly polarized light of s-type from PBS 271, the s-shoulder to p-shoulder spacing (marked s-to-p in FIG. 89) must be very wide. This is very difficult to achieve over the present wavelength range. To transmit linearly polarized light of s-type through PBS 271,

the s-type transmission peak dimension (marked s-trans in FIG. 89) must be wide. This is also difficult to achieve. Thus the solution effected in the present embodiment is to transmit both the 780-nanometer beams and the 850-nanometer beams with p-type linear polarization. The optical apparatus of sub-unit 240 (FIG. 88) is used because DM 243 is relatively insensitive to polarization and angle of incidence when used at approximately zero degrees.

Beam combination sub-unit 270 (FIG. 90) combines the two signal (information) beam arrays with the power/control beam array by again using space-multiplexing. Recall that optical crossover interconnect 100 generates two signal beam arrays, spatially overlapped, but on different polarizations. One signal beam array, having s-type linear polarization, is reflected from PBS 271, passes through QWP 272, reflects off of the mirrors of PMR 274 and passes through QWP 272, PBS 271, and QWP 279 onto S-SEED array 500. The other signal beam array, having p-type linear polarization, is transmitted through PBS 271 and QWP 282, reflected off of the mirrors of PMR 278, again passes through QWP 282 and is reflected by PBS 271 onto S-SEED array 500 via QWP 279. Since the signal beam arrays produce overlapped spot arrays when focused (FIG. 91), PMR 274 and PMR 278 are identically aligned. The two signal arrays are reflected off the PMRs 274 and 278 as shown in FIG. 91. As shown, the mirrors of PMRs 274 and 278 are aligned with the diode windows of the S-SEEDs. The diode windows are large enough to admit two spots side by side as shown in FIG. 92. The power/control beam array is passed onto the S-SEEDs in the same manner as the preset beams in FIG. 87. The power/control beams are focused through the transparent arm of PMR 274 adjacent to the mirrors as shown in FIG. 91. Thus, they are incident on the S-SEED input windows adjacent to the signal spots as in FIG. 92. The preset and disable spots are focused on different diodes of each S-SEED, and with the signal spots, set the state of the S-SEED. The power spots read out the dual-rail state of each S-SEED. The reflected output beams are then imaged through the transparent areas of PMR 278 adjacent to the mirrors. Since the output beams emerge after being recollimated still circularly polarized from QWP 282, the polarization is correct for the beams to be received by the optical crossover interconnect 100 of the next stage. The polarization conversions of the 780-nanometer control beams effected by QWPs 272 and 276 are the same as the conversions by QWPs 242 and 244 in beam combination sub-unit 240 (FIG. 88). Lenses 273, 275, and 277 (FIG. 90) which relay the spot array images on, off, and through PMRs 274 and 278 have focal lengths greater than 30 mm as in sub-unit 210. Lens 280 next to S-SEED array 500 produces very small spots, however, and has a focal length less than 10 mm. Each of the lenses 273 and 277, inside PMRs 274 and 278 respectively, combine with lens 280 to form a minifying telescope. PMRs 274 and 278 can be scaled larger than the devices by the reciprocal of the minification factor, which eases their production tolerances.

The various optical units described above are interconnected such that the required polarization orientations are maintained, but beyond that, their relative orientations and spacings may be adjusted to facilitate the image relaying or the overall physical layout. One possible arrangement is shown for optical hardware module 51 in FIG. 93. Two cascaded optical hardware modules 50 and 51 are shown in FIGS. 95-96.

As mentioned previously, the data signals entering photonic system 10 have been first processed electrically. Each electrical signal channel is used to drive a separate laser diode. The laser diodes are connected to multi-mode fibers or single-mode fibers which are formed into a matrix with the necessary aspect ratio, e.g., the 2 x 8 fiber cable array 21 of FIG. 1. In addition to spatially aligning the input channels with the S-SEEDs of the S-SEED array 500, the single-rail signals are converted to dual-rail and normalized or regenerated to the appropriate levels. This is accomplished using the optical arrangement of data input unit 40 (FIG. 97). The single-rail input signal from each fiber in the cable array 21 is imaged onto only one S-SEED diode of S-SEED array 500. The preset spots are imaged onto the other diode of each device such that if a logic zero bit (no light intensity) is received, the S-SEED is already switched into the logic zero state. If a logic one bit is received, the S-SEED is reset into the logic one state. The fiber cable array 21 output is first collimated into an array of beams by lens 80 before passing through PBS 271. If the fibers forming the cable array 21 are short lengths of multi-mode fiber, the beam array may be almost randomly polarized. PBS 271 splits the cable array image into two copies. The copies are reflected by PMRs 274 and 278 and are imaged onto one of the diodes of each S-SEED. The preset beams are passed through beam combination sub-unit 240 and through the transparent areas of PMR 274 to be imaged onto the S-SEED diodes which are not being set by the signal spots. The power beams are also combined via beam combination sub-unit 240 and are imaged onto all of the diode windows, adjacent to either the preset or signal spot locations, in a manner similar to that of FIG. 92. The reflected and modulated power spots then form the regenerated dual-rail input signals to be routed through the rest of photonic system 10. At the output of the last optical hardware module 57 (FIG. 1), a lens 70 images the output signals onto a 2 x 8 fiber cable array 22. The fibers of array 22 terminate on photodetectors (not shown) which convert the

signals back to the electrical domain for the required transmission conditioning. Since the output fiber matrix can be aligned with either of the S-SEED diodes, a data inversion can also be performed as required to compensate for an odd number of previous data inversions.

An alternative optical arrangement for performing wavelength-dependent beam combination is shown in FIG. 98 as comprising PBS 8101, QWP 8102, DM 8103, and QWP 8104. PBS 8101, QWP 8102 and QWP 8104 are designed for 850-nanometer operation. The combined power and control beams both have s-type linear polarization.

A second alternative optical arrangement for performing wavelength-dependent beam combination is shown in FIG. 99 as comprising PBS 8201, QWP 8202, DM 8203, and QWP 8204. PBS 8201, QWP 8202 and QWP 8204 are designed for 780-nanometer operation. The combined power and control beams both have s-type linear polarization.

A further alternative optical arrangement for performing wavelength-dependent beam combination is shown in FIG. 100 as comprising PBS 8301, QWP 8302, DM 8303, QWP 8304, QWP 8305, DM 8306, and QWP 8307. PBS 8301, QWP 8302, QWP 8304, QWP 8305, and QWP 8307 are designed for 850-nanometer operation. Two of the combined beams have s-type linear polarization and the other two of the combined beams have p-type linear polarization.

### Claims

1. A system (10, FIG. 1; 2110, FIGS. 55-57) having N inlets and M outlets, said system comprising
  - a plurality of stages (N2-N6) of switching nodes, each node having at least one input and at least one output and where the sum of the number of inputs and the number of outputs for a node is greater than two, the number of said plurality of node stages being at least four,
  - a plurality of stages (L2-L5) of links, each link stage for connecting the outputs of one of said node stages to the inputs of the successive one of said node stages, said plurality of node stages and said plurality of link stages collectively comprising a perfect shuffle equivalent network,
  - CHARACTERISED IN THAT said system further comprises
    - means (N0, L0, N1, L1) for expanding said N inlets to at least (F x N) inputs of the first one (N2) of said node stages, F being a positive integer greater than or equal to four, and
    - means (L6, N7, L7, N8) for concentrating at least (F x M) outputs of the last one (N6) of said node stages to said M outlets,
  - said system having at least two paths between each of said N inlets and each output of said last node stage.
2. A system in accordance with claim 1 wherein each of said node stages comprises
  - a plurality (500, FIG. 58) of optical switching nodes each having at least two optical states,
  - means for generating an array (DISABLE or PRESET, FIG. 93) of control beams each for controlling the optical state of a corresponding one of said switching nodes and
  - free-space optical means (200, FIG. 93) for directing each of said control beams to the corresponding one of said switching nodes.
3. A system in accordance with claim 2 wherein said array of control beams comprises an array (DISABLE, FIG. 93) of disable beams each for disabling communication of optical information through a corresponding one of said switching nodes.
4. A system in accordance with claim 2 wherein said generating means comprises
  - means (401-408, FIG. 86) for generating a uniform array of beams corresponding to said plurality of switching nodes and
  - means (409, FIG. 86) responsive to electrical control signals for selectively transmitting ones of said uniform array of beams to form said array of control beams.
5. A system in accordance with claim 4 further comprising
  - means (60, FIG. 1) responsive to requests for connections through said system for generating said electrical control signals.
6. A system in accordance with claim 2 wherein said each node stage further comprises
  - means for generating an array (PRESET, FIG. 93) of preset beams each for establishing the optical state of a corresponding one of said switching nodes prior to the communication of optical information

therethrough and

free-space optical means (200, FIG. 93) for directing each of said preset beams to the corresponding one of said switching nodes.

- 5 7. A system in accordance with claim 1 where each of said plurality of switching nodes has at least two optical states and wherein said each node stage further comprises  
means for generating an array (POWER, FIG. 93) of power beams each for reading the optical state of a corresponding one of said switching nodes and  
10 free-space optical means (200, FIG. 93) for directing each of said power beams to the corresponding one of said switching nodes.
8. A system in accordance with claim 7 wherein said each node stage further comprises  
free-space optical means (270, FIG. 93) for directing ones of said power beams reflected from said plurality of switching nodes to form an array of output beams.
- 15 9. A system in accordance with claim 1 wherein said each node stage further comprises  
a plurality (500, FIG. 58) of optical switching nodes each having at least two optical states, said plurality of optical switching nodes for receiving first and second arrays of information beams comprising information for communication through said network, said first and second arrays of  
20 information beams each corresponding to said plurality of switching nodes and  
free-space optical means (100, 270, FIG. 93) for directing each information beam of said first and second arrays to the corresponding one of said switching nodes.
10. A system in accordance with claim 9, said plurality of optical switching nodes each having at least two  
25 optical states, wherein said each node stage further comprises  
means for generating an array (POWER, FIG. 93) of power beams each for reading the optical state of a corresponding one of said switching nodes and  
free-space optical means (200, FIG. 93) for directing each of said power beams to the corresponding  
30 one of said switching nodes.
11. A system in accordance with claim 10 further comprising  
means for generating an array (PRESET, FIG. 93) of preset beams each for establishing the optical  
state of a corresponding one of said switching nodes prior to the communication of optical information  
therethrough and  
35 free-space optical means (200, FIG. 93) for directing each of said preset beams to the corresponding one of said switching nodes.
12. A system in accordance with claim 1 where each node of at least one (N4) of said node stages  
40 comprises  
optical means (2125, FIG. 63; 2134, FIG. 68; 2138, FIG. 71) responsive to a control signal for broadcasting an output signal to at least two of the nodes of the succeeding one of said node stages, said output signal comprising a logical combination of signals receivable from at least two of the nodes of the preceding one of said node stages.
- 45 13. A system in accordance with claim 12 wherein said output signal and said receivable signals are optical signals.
14. A system in accordance with claim 13 wherein said output signal and said receivable signals have a  
50 given wavelength and said control signal has a wavelength other than said given wavelength.
15. A system in accordance with claim 14 wherein a first one of said receivable signals comprises a first  
data input signal and a first complementary data input signal, a second one of said receivable signals  
comprises a second data input signal and a second complementary data input signal, and said output  
signal comprises a data output signal and a complementary data output signal, said broadcasting  
55 means comprising  
a symmetric self electro-optic effect device comprising a first photodetector (R-Q) including a quantum well region and a second photodetector (S-Q) including a quantum well region,  
said first photodetector being optically coupled to both of said two preceding stage nodes for

receiving said first and second data input signals, said first photodetector being optically coupled to both of said two succeeding stage nodes for transmitting said data output signal,

said second photodetector being optically coupled to both of said two preceding stage nodes for receiving said first and second complementary data input signals, said second photodetector being optically coupled to both of said two succeeding stage nodes for transmitting said complementary data output signal.

16. A system in accordance with claim 1 wherein each of said link stages comprises means (100, FIG. 93) for providing optical connectivity from the outputs of one of said node stages to the inputs of the successive one of said node stages.

17. A system in accordance with claim 1 wherein said expanding means comprises electrical means.

18. A system in accordance with claim 1 wherein said expanding means comprises optical means.

19. A system in accordance with claims 17 or 18 wherein said expanding means connects each of said N inlets to F inputs of said first node stage (N2).

20. A system in accordance with claim 19 wherein said expanding means connects each of said N inlets to F inputs of said first node stage (N2) in a perfect shuffle sustaining pattern.

21. A system in accordance with claim 19 wherein said expanding means connects each of said N inlets to F inputs of said first node stage (N2) in a perfect shuffle sustaining pattern, F being a power of two, wherein each of said plurality of node stages comprises the same number of nodes, and wherein each of the nodes of said plurality of node stages has two inputs and two outputs.

22. A system in accordance with claim 21 wherein said expanding means comprises  $\log_2 F$  stages (N0, L0, N1, L1) each comprising a plurality of nodes each having one input and two outputs.

23. A system in accordance with claim 1 wherein said concentrating means comprises electrical means.

24. A system in accordance with claim 1 wherein said concentrating means comprises optical means.

25. A system in accordance with claims 23 or 24 wherein said concentrating means connects F outputs of said last node stage (N6) to each of said M outlets.

26. A system in accordance with claim 25 wherein said concentrating means connects F outputs of said last node stage (N6) to each of said M outlets in a perfect shuffle sustaining pattern.

27. A system in accordance with claim 25 wherein said concentrating means connects F outputs of said last node stage (N6) to each of said M outlets in a perfect shuffle sustaining pattern, F being a power of two, wherein each of said plurality of node stages comprises the same number of nodes, and wherein each of the nodes of said plurality of node stages has two inputs and two outputs.

28. A system in accordance with claim 27 wherein said concentrating means comprises  $\log_2 F$  stages (L6, N7, L7, N8) each comprising a plurality of nodes each having two inputs and one output.

29. A system in accordance with claim 1 wherein each of said node stages comprises a plurality (500, FIG. 8) of optical switching nodes each having at least two optical states, means for receiving at least one array of information beams comprising information for communication through said network, said at least one array corresponding to said plurality of switching nodes, free-space optical means (100, 270, FIG. 93) for directing each information beam of said at least one array to the corresponding one of said switching nodes, means for generating a plurality (DISABLE or PRESET, FIG. 93) of control signals independent of said information beams and each for controlling the optical state of a corresponding one of said switching nodes.

30. A system in accordance with claim 29 wherein said optical switching nodes are capacity one nodes.
31. A system in accordance with claims 29 or 30, said system comprising bulk optical means and not including microoptical means.
- 5 32. A system in accordance with claim 1 wherein each of said node stages comprises a plurality (500, FIG. 58) of capacity one optical switching nodes each having at least two optical states.
- 10 33. A system in accordance with claims 1 or 32, said system comprising bulk optical means and not including microoptical means.
34. A system in accordance with claim 1 which is nonblocking.
- 15 35. A system in accordance claim 1, which has arbitrarily low blocking probability dependent on F and the number of said node stages and link stages.

### Patentansprüche

- 20 1. System (10, Fig. 1; 2110, Fig. 55 bis 57) mit N-Eingängen und M-Ausgängen sowie mit folgenden Merkmalen:  
eine Mehrzahl von Stufen (N2 bis N6) von Schaltknoten, die jeweils mindestens einen Eingang und mindestens einen Ausgang aufweisen, wobei die Summe der Anzahl der Eingänge und der Anzahl der Ausgänge eines Knotens größer als zwei ist und die Anzahl der Mehrzahl der Knotenstufen mindestens vier beträgt,  
25 eine Mehrzahl von Stufen (L2 bis L5) von Zwischenleitungen, die jeweils zur Verbindung der Ausgänge einer Knotenstufe mit den Eingängen der darauf folgenden Knotenstufe dienen, wobei die Mehrzahl der Knotenstufen und die Mehrzahl der Zwischenleitungsstufen gemeinsam ein äquivalentes Netzwerk zum perfekten Umordnen (perfect shuffle) darstellen,  
30 gekennzeichnet durch folgende weitere Merkmale:  
eine Einrichtung (N0,L0,N1,L1) zur Ausdehnung der N-Einlässe auf mindestens (F x N)Eingänge der ersten Knotenstufe (N2), wobei F eine positive Zahl größer oder gleich 4 ist,  
eine Einrichtung (L6,N7,L7,N8) zur Konzentration von mindestens (F x N)Ausgängen der letzten Knotenstufe (N6) auf M Auslässe,  
35 das System weist mindestens zwei Wege zwischen jedem der N Einlässe und jedem Ausgang der letzten Knotenstufe auf.
2. System nach Anspruch 1, dadurch gekennzeichnet, daß die jeweiligen Knotenstufen folgendes umfassen:  
40 eine Mehrzahl (500, Fig. 58) von optischen Schaltknoten, die jeweils mindestens zwei optische Zustände aufweisen,  
eine Einrichtung zur Erzeugung einer Anordnung (Trennen oder Voreinstellung, Fig. 93) von Steuerstrahlenbündeln, die jeweils den optischen Zustand eines entsprechenden Schaltknotens steuern, und  
eine optische Freiraumübertragungs-Einrichtung (200, Fig. 93), um das jeweilige Steuerstrahlenbündel  
45 zu dem entsprechenden Schaltknoten zu lenken.
3. System nach Anspruch 2, dadurch gekennzeichnet, daß die Anordnung der Steuerstrahlenbündel ein Feld (Trennen, Fig. 93) von Trennstrahlenbündeln aufweist, die jeweils zum Abschalten der Kommunikation der optischen Information über einen entsprechenden Schaltknoten dienen.
- 50 4. System nach Anspruch 2, dadurch gekennzeichnet, daß die Erzeugungseinrichtung eine Einrichtung (401 bis 408, Fig. 86) zur Erzeugung einer gleichförmigen Anordnung von Strahlen entsprechend der Mehrzahl der Schaltknoten und  
eine Einrichtung (409, Fig. 86) umfaßt, die auf die elektrischen Steuersignale anspricht und eine der  
55 gleichförmigen Anordnungen der Strahlen selektiv überträgt, um die Anordnung der Steuerstrahlen zu bilden.

5. System nach Anspruch 4, dadurch gekennzeichnet, daß eine Einrichtung (60, Fig. 1) auf Anforderungen für Verbindungen über das System zur Erzeugung der elektrischen Steuersignale anspricht.
6. System nach Anspruch 2, dadurch gekennzeichnet, daß jede Knotenstufe  
 5 eine Einrichtung zur Erzeugung einer Anordnung (Voreinstellung, Fig. 93) von Voreinstellstrahlenbündeln umfaßt, die jeweils zur Errichtung des optischen Zustands eines entsprechenden Schaltknotens vor der Hindurchleitung von optischen Informationen dienen, und daß die optische Freiraumübertragungs-Einrichtung (200, Fig. 93) zur Lenkung des jeweiligen Voreinstellstrahls zu dem entsprechenden Schaltknoten dient.
7. System nach Anspruch 1, dadurch gekennzeichnet, daß jeder der Mehrzahl der Schaltknoten mindess-  
 10 tens zwei optische Zustände aufweist und daß jeder Schaltknoten eine Einrichtung zur Erzeugung einer Anordnung (Leistung, Fig. 93) von Leistungsstrahlen, die jeweils zur Auslesung des optischen Zustandes eines entsprechenden Schaltknotens dienen, und  
 15 eine optische Freiraumübertragungs-Einrichtung (200, Fig. 93) zur Lenkung der jeweiligen Leistungsstrahlen zu entsprechenden Schaltknoten umfaßt.
8. System nach Anspruch 7, dadurch gekennzeichnet, daß jede Knotenstufe eine optische Freiraumüber-  
 20 tragungs-Einrichtung (270, Fig. 93) zur Lenkung der jeweiligen, von der Mehrzahl der Schaltknoten reflektierten Leistungsstrahlen aufweist, um eine Anordnung von Ausgangsstrahlen zu bilden.
9. System nach Anspruch 1, dadurch gekennzeichnet, daß jede Knotenstufe folgendes umfaßt:  
 25 eine Mehrzahl (500, Fig. 58) von optischen Schaltknoten, die jeweils mindestens zwei optische Zustände aufweisen, wobei die Mehrzahl der optischen Schaltknoten zum Empfang erster und zweiter Anordnungen von Informationsstrahlen dienen, die Information zur Kommunikation durch das Netzwerk enthalten, wobei ferner die erste und zweite Anordnungen der Informationsstrahlen jeweils der Mehrzahl der Schaltknoten entsprechen, und  
 eine optische Freiraumübertragungs-Einrichtung (100,270, Fig. 93) zur Lenkung des jeweiligen Informationsstrahls der ersten und zweiten Anordnung zu dem entsprechenden Schaltknoten.
10. System nach Anspruch 9, dadurch gekennzeichnet, daß die Mehrzahl der optischen Schaltknoten  
 30 jeweils mindestens zwei optische Zustände aufweist und daß jeder Schaltknoten ferner eine Einrichtung zur Erzeugung einer Anordnung (Leistung, Fig. 93) von Leistungsstrahlen umfaßt, die jeweils zum Auslesen des optischen Zustandes eines entsprechenden Schaltknotens dienen, und  
 35 eine optische Freiraumübertragungs-Einrichtung (200, Fig. 93) zur Lenkung der jeweiligen Leistungsstrahlen auf die entsprechenden Schaltknoten aufweist.
11. System nach Anspruch 10, dadurch gekennzeichnet, daß eine Einrichtung zur Erzeugung einer  
 40 Anordnung (Voreinstellung, Fig. 93) von Voreinstellstrahlen vorgesehen ist, die jeweils den optischen Zustand eines entsprechenden Schaltknotens vor der Hindurchleitung von optischer Information errichtet, und daß eine optische Freiraumübertragungs-Einrichtung (200, Fig. 93) zur Lenkung des jeweiligen Voreinstellstrahls zu dem entsprechenden Schaltknoten vorgesehen ist.
12. System nach Anspruch 1, dadurch gekennzeichnet, daß jeder Knoten von mindestens einem (N4) der  
 45 Knotenstufen eine optische Einrichtung (2125, Fig) 63; 2134, Fig. 68; 2138, Fig. 71) umfaßt, die auf ein Steuersignal anspricht, um ein Ausgangssignal an mindestens zwei Knoten der nachfolgenden Knotenstufe zu senden, wobei das Ausgangssignal eine logische Kombination der Signale aufweist, die von mindestens zwei der Knoten der vorhergehenden Knotenstufe empfangen werden können.
13. System nach Anspruch 12, dadurch gekennzeichnet, daß das Ausgangssignal und die empfangbaren  
 50 Signale optische Signale darstellen.
14. System nach Anspruch 13, dadurch gekennzeichnet, daß das Ausgangssignal und die empfangbaren  
 55 Signale eine gegebene Wellenlänge aufweisen und daß das Steuersignal eine andere Wellenlänge als die gegebene Wellenlänge aufweist.
15. System nach Anspruch 14, dadurch gekennzeichnet, daß ein erstes empfangbares Signal ein erstes  
 Dateneingangssignal und ein erstes komplementäres Dateneingangssignal umfaßt, daß ein zweites

empfangbares Signal ein zweites Dateneingangssignal und ein zweites komplementäres Dateneingangssignal umfaßt, und daß das Ausgangssignal ein Datenausgangssignal und ein komplementäres Datenausgangssignal umfaßt, wobei die Sendeeinrichtung folgende Merkmale aufweist:

5 ein Bauteil mit symmetrischem selbst-elektrooptischem Effekt (S-SEED) weist einen ersten Fotodetektor (R-Q) mit einer Quantumquellenregion und einen zweiten Fotodetektor (S-Q) mit einer Quantumquellenregion auf,

der erste Fotodetektor ist optisch mit beiden vorhergehenden Zustandsknoten zum Empfang der ersten und zweiten Dateneingangssignale und auch mit beiden nachfolgenden Zustandsknoten zur Übertragung der Datenausgangssignale optisch gekoppelt,

10 der zweite Fotodetektor ist mit beiden vorhergehenden Zustandsknoten zum Empfang der ersten und zweiten komplementären Dateneingangssignale und auch mit beiden nachfolgenden Zustandsknoten zur Übertragung der komplementären Datenausgangssignale optisch gekoppelt.

16. System nach Anspruch 1, dadurch gekennzeichnet, daß die jeweiligen Zwischenleitungsstufen Einrichtungen (100, Fig. 93) umfassen, die zur optischen Verbindbarkeit von den Ausgängen einer Knotenstufe zu den Eingängen der nachfolgenden Knotenstufe dienen.

17. System nach Anspruch 1, dadurch gekennzeichnet, daß die Ausdehnungseinrichtung elektrische Bauteile umfaßt.

20 18. System nach Anspruch 1, dadurch gekennzeichnet, daß die Ausdehnungseinrichtung optische Bauteile umfaßt.

25 19. System nach Anspruch 17 oder 18, dadurch gekennzeichnet, daß die Ausdehnungseinrichtung die jeweiligen N Eingänge mit den F Eingängen der ersten Knotenstufe (N2) verbindet.

20. System nach Anspruch 19, dadurch gekennzeichnet, daß die Ausdehnungseinrichtung die jeweiligen N Eingänge mit den F Eingängen der ersten Knotenstufe (N2) in einem perfekten Umordnungserhaltungsmuster verbindet.

30 21. System nach Anspruch 19, dadurch gekennzeichnet, daß die Ausdehnungseinrichtung die jeweiligen N Eingänge mit den F Eingängen der ersten Knotenstufe (N2) in einem perfekten Umordnungserhaltungsmuster verbindet, wobei F eine Potenz von zwei darstellt, daß jede Knotenstufe der Mehrzahl die gleiche Anzahl von Knoten umfaßt und daß jeder Knoten der Mehrzahl der Knotenstufen zwei Eingänge und zwei Ausgänge aufweist.

35 22. System nach Anspruch 21, dadurch gekennzeichnet, daß die Ausdehnungseinrichtung  $\log_2 F$ -Stufen (N0, L0, N1, L1) umfaßt, die jeweils eine Mehrzahl von Knoten mit jeweils einem Eingang und zwei Ausgängen aufweist.

40 23. System nach Anspruch 1, dadurch gekennzeichnet, daß die Konzentrationseinrichtung elektrische Bauteile aufweist.

45 24. System nach Anspruch 1, dadurch gekennzeichnet, daß die Konzentrationseinrichtung optische Bauteile aufweist.

25. System nach Anspruch 23 oder 24, dadurch gekennzeichnet, daß die Konzentrationseinrichtung F Ausgänge der letzten Knotenstufe (N6) mit jedem der M Ausgänge verbindet.

50 26. System nach Anspruch 25, dadurch gekennzeichnet, daß die Konzentrationseinrichtung F Ausgänge der letzten Knotenstufe (N6) mit den jeweiligen M Ausgängen in einem perfekten Umordnungserhaltungsmuster verbindet.

55 27. System nach Anspruch 25, dadurch gekennzeichnet, daß die Konzentrationseinrichtung F Ausgänge der letzten Knotenstufe (N6) mit den jeweiligen M Ausgängen in einem perfekten Umordnungserhaltungsmuster verbindet, wobei F eine Potenz von zwei darstellt, daß jede Knotenstufe der Mehrzahl die gleiche Anzahl von Knoten aufweist und daß jeder Knoten der Mehrzahl der Knotenstufen zwei Eingänge und zwei Ausgänge besitzt.

28. System nach Anspruch 27, dadurch gekennzeichnet, daß die Konzentrationseinrichtung  $\log_2 F$  Stufen (L6,N7,L7,N8) aufweist, die jeweils eine Mehrzahl von Knoten mit jeweils zwei Eingängen und einem Ausgang aufweisen.

5 29. System nach Anspruch 1, dadurch gekennzeichnet, daß jede Knotenstufe eine Mehrzahl (500, Fig. 8) optischer Schaltknoten mit jeweils mindestens zwei optischen Zuständen aufweist, daß eine Einrichtung zum Empfang mindestens einer Anordnung von Informationsstrahlen mit Information zur Kommunikation durch das Netzwerk vorgesehen ist, wobei mindestens eine Anordnung der Mehrzahl der Schaltknoten entspricht,  
 10 daß eine optische Freiraumübertragungs-Einrichtung (100,270, Fig. 93) zur Lenkung des jeweiligen Informationsstrahls der mindestens einen Anordnung zu dem entsprechenden Schaltknoten vorgesehen ist, und daß eine Einrichtung zur Erzeugung einer Mehrzahl (Trennen oder Voreinstellung, Fig. 93) von Steuersignalen unabhängig von den Informationsstrahlen vorgesehen ist, die jeweils zur Steuerung des optischen Zustands eines entsprechenden Schaltknotens dienen.  
 15

30. System nach Anspruch 29, dadurch gekennzeichnet, daß die optischen Schaltknoten das Kapazitätswolumen eins besitzen.

20 31. System nach Anspruch 29 oder 30, dadurch gekennzeichnet, daß das System räumliche optische Bauteile umfaßt, nicht jedoch mikrooptische Bauteile.

32. System nach Anspruch 1, dadurch gekennzeichnet, daß jede Knotenstufe eine Mehrzahl (500, Fig. 58) optische Schaltknoten mit Kapazitätswolumen eins umfaßt, die jeweils mindestens zwei optische Zustände aufweisen.  
 25

33. System nach Anspruch 1 oder 32, dadurch gekennzeichnet, daß es räumliche optische Bauteile umfaßt, jedoch keine mikrooptischen Bauteile.

30 34. System nach Anspruch 1, dadurch gekennzeichnet, daß es nicht blockierend ist.

35. System nach Anspruch 1, dadurch gekennzeichnet, daß es eine willkürlich niedrige Blockierwahrscheinlichkeit in Abhängigkeit von F und der Anzahl der Knotenstufen und Zwischenleitungsstufen aufweist.

35 **Revendications**

1. Un système (10, figure 1 ; 2 110, figures 55-57) ayant N accès d'entrée et M d'accès de sortie, ce système comprenant

un ensemble d'étages (N2-N6) de noeuds de commutation, chaque noeud ayant au moins une entrée et au moins une sortie, et la somme du nombre d'entrées et du nombre de sorties pour un noeud étant supérieure à deux, le nombre des étages de cet ensemble d'étages de noeuds étant au moins de quatre,  
 40

un ensemble d'étages (L2-L5) de mailles, chaque étage de maille étant destiné à connecter les sorties de l'un des étages de noeuds aux entrées de l'étage successif parmi les étages de noeuds, l'ensemble d'étages de noeuds et l'ensemble d'étages de mailles constituant collectivement un réseau équivalent à brassage parfait,  
 45

CARACTERISE EN CE QUE le système comprend en outre

des moyens (N0, L0, N1, L1) pour effectuer une expansion des N accès d'entrée vers au moins (F x N) entrées du premier (N2) des étages de noeuds, F étant un entier positif supérieur ou égal à quatre, et  
 50

des moyens (L6 N7, L7, N8) pour concentrer au moins (F x M) sorties du dernier (N6) des étages de noeuds vers M accès de sortie,

le système ayant au moins deux itinéraires entre chacun des N accès d'entrée et chaque sortie du dernier étage de noeuds.  
 55

2. Un système selon la revendication 1, dans lequel chacun des étages de noeuds comprend un ensemble (500, figure 58) de noeuds de commutation optiques ayant chacun au moins deux états optiques,

des moyens destinés à générer un réseau (DISABLE ou PRESET, figure 93) de faisceaux de commande pour commander l'état optique de l'un correspondant des noeuds de commutation, et des moyens optiques en espace libre (200, figure 93) pour diriger chacun des faisceaux de commande vers le noeud correspondant parmi les noeuds de commutation.

5

3. Un système selon la revendication 2, dans lequel le réseau de faisceaux de commande comprend un réseau (DISABLE, figure 93) de faisceaux de désactivation ayant chacun pour fonction de désactiver la transmission d'information optique à travers l'un correspondant des noeuds de commutation.

10

4. Un système selon la revendication 2, dans lequel les moyens de génération comprennent des moyens (401-408, figure 86) pour générer un réseau uniforme de faisceaux correspondant à l'ensemble de noeuds de commutation, et des moyens (409, figure 86) qui réagissent à des signaux de commande électriques de façon à transmettre sélectivement certains des faisceaux du réseau uniforme de faisceaux, pour former le

15

5. Un système selon la revendication 4, comprenant en outre des moyens (60, figure 1) qui réagissent à des demandes de connexions par le système en générant les signaux de commande électriques.

20

6. Un système selon la revendication 2, dans lequel chaque étage de noeuds comprend en outre des moyens pour générer un réseau (PRESET, figure 93) de faisceaux de prépositionnement, ayant chacun pour fonction d'établir l'état optique de l'un correspondant des noeuds de commutation, avant la transmission d'information optique à travers celui-ci, et

25

des moyens optiques en espace libre (200, figure 93) pour diriger chacun des faisceaux de prépositionnement vers le noeud correspondant parmi les noeuds de commutation.

7. Un système selon la revendication 1, dans lequel chaque noeud parmi l'ensemble de noeuds de commutation comporte au moins deux états optiques, et dans lequel chaque étage de noeuds comprend en outre

30

des moyens pour générer un réseau (POWER, figure 93) de faisceaux de puissance ayant chacun pour fonction de lire l'état optique de l'un correspondant des noeuds de commutation, et des moyens optiques en espace libre (200, figure 93) pour diriger chacun des faisceaux de puissance vers le noeud correspondant parmi les noeuds de commutation.

35

8. Un système selon la revendication 7, dans lequel chaque étage de noeuds comprend en outre des moyens optiques en espace libre (270, figure 93) pour diriger certains des faisceaux de puissance qui sont réfléchis à partir de l'ensemble de noeuds de commutation, pour former un réseau de faisceaux de sortie.

40

9. Un système selon la revendication 1, dans lequel chaque étage de noeuds comprend en outre un ensemble (500, figure 58) de noeuds de commutation optiques ayant chacun au moins deux états optiques, cet ensemble de noeuds de commutation optiques étant destiné à recevoir des premier et second réseaux de faisceaux d'information constituant de l'information à transmettre à travers le réseau, les premier et second réseaux de faisceaux d'information correspondant chacun à l'ensemble de noeuds de commutation, et

45

des moyens optiques en espace libre (100, 270, figure 93) pour diriger chaque faisceau d'information des premier et second réseaux vers le noeud correspondant parmi les noeuds de commutation.

50

10. Un système selon la revendication 9, dans lequel chaque noeud de l'ensemble de noeuds de commutation optiques comporte au moins deux états optiques, et dans lequel chaque étage de noeuds comprend en outre

55

des moyens pour générer un réseau (POWER, figure 93) de faisceaux de puissance, ayant chacun pour fonction de lire l'état optique de l'un correspondant des noeuds de commutation, et des moyens optiques en espace libre (200, figure 93) pour diriger chacun des faisceaux de puissance vers l'un correspondant des noeuds de commutation.

11. Un système selon la revendication 10, comprenant en outre  
 des moyens pour générer un réseau (PRESET, figure 93) de faisceaux de prépositionnement ayant  
 chacun pour fonction d'établir l'état optique de l'un correspondant des noeuds de commutation, avant  
 la transmission d'information optique à travers celui-ci, et  
 5 des moyens optiques en espace libre (200, figure 93) pour diriger chacun des faisceaux de  
 prépositionnement vers le noeud correspondant parmi les noeuds de commutation.
12. Un système selon la revendication 1, dans lequel chaque noeud de l'un au moins (N4) des étages de  
 noeuds comprend  
 10 des moyens optiques (2125, figure 63 ; 2234, figure 68 ; 2138, figure 71) réagissant à a signal de  
 commande en diffusant un signal de sortie vers deux au moins des noeuds de l'étage suivant parmi les  
 étages de noeuds, ce signal de sortis comprenant une combinaison logique de signaux pouvant être  
 reçus à partir de deux au moins des noeuds de l'étage précédent parmi les étages de noeuds.
13. Un système selon la revendication 12, dans lequel le signal de sortie et les signaux pouvant être reçus  
 15 sont des signaux optiques.
14. Un système selon la revendication 13, dans lequel le signal de sortie et les signaux pouvant être reçus  
 ont une longueur d'onde donnée et le signal de commande a une longueur d'onde autre que cette  
 20 longueur d'onde donnée.
15. Un système selon la revendication 14, dans lequel un premier des signaux pouvant être reçus  
 comprend un premier signal d'entrée de données et un premier signal d'entrée de données complé-  
 mentaire, un second des signaux pouvant être reçus comprend un second signal d'entrée de données  
 25 et un second signal d'entrée de données complémentaire, et le signal de sortie comprend un signal de  
 sortie de données et un signal de sortie de données complémentaire, les moyens de diffusion  
 comprenant  
 un dispositif à effet auto-électrooptique symétrique, comprenant un premier photodétecteur (R-Q)  
 qui comporte une région de puits quantique et un second photodétecteur (S-Q) qui comporte une  
 30 région de puits quantique,  
 le premier photodétecteur étant en couplage optique avec les deux noeuds de l'étage précédent  
 pour recevoir les premier et second signaux d'entrée de données, ce premier photodétecteur étant en  
 couplage optique avec les deux noeuds de l'étage suivant pour émettre le signal de sortie de données,  
 le second photodétecteur étant en couplage optique avec les deux noeuds de l'étage précédent  
 35 pour recevoir la premier et second signaux d'entrée de données complémentaires, et le second  
 photodétecteur étant en couplage optique avec les deux noeuds de l'étage suivant pour émettre le  
 signal de sortie de données complémentaire.
16. Un système selon la revendication 1, dans lequel chacun des étages de mailles comprend des moyens  
 40 (100, figure 93) pour procurer une possibilité de connexion optique à partir des sorties de l'un des  
 étages de noeuds vers les entrées de l'étage suivant parmi les étages de noeuds.
17. Un système selon la revendication 1, dans lequel les moyens d'expansion comprennent des moyens  
 électriques.
18. Un système selon la revendication 1, dans lequel les moyens d'expansion comprennent des moyens  
 45 optiques.
19. Un système selon les revendications 17 ou 18, dans lequel les moyens d'expansion connectent chacun  
 50 des N accès d'entrée à F entrées du premier étage de noeuds (N2).
20. Un système selon la revendication 19, dans lequel les moyens d'expansion connectent chacun des N  
 accès d'entrée à F entrées du premier étage de noeuds (N2) selon une configuration permettant un  
 brassage parfait.
21. Un système selon la revendication 19, dans lequel les moyens d'expansion connectent chacun des N  
 55 accès d'entrée à F entrées du premier étage de noeuds (N2) selon une configuration permettant un  
 brassage parfait, F étant une puissance de deux, dans lequel chaque étage de l'ensemble d'étages de

noeuds comprend le même nombre de noeuds, et dans lequel chacun des noeuds de l'ensemble d'étages de noeuds a deux entrées et deux sorties.

- 5 22. Un système selon la revendication 21, dans lequel les moyens d'expansion comprennent  $\log_2 F$  étages (N0, L0, N1, L1) comprenant chacun un ensemble de noeuds ayant chacun une entrée et deux sorties.
- 10 23. Un système selon la revendication 1, dans lequel les moyens de concentration comprennent des moyens électriques.
24. Un système selon la revendication 1, dans lequel les moyens de concentration comprennent des moyens optiques.
- 15 25. Un système selon les revendications 23 ou 24, dans lequel les moyens de concentration connectent F sorties du dernier étage de noeuds (N6) à chacun des M accès de sortie.
- 20 26. Un système selon la revendication 25, dans lequel les moyens de concentration connectent F sorties du dernier étage de noeuds (N6) à chacun des M accès de sortie selon une configuration permettant un brassage parfait.
- 25 27. Un système selon la revendication 25, dans lequel les moyens de concentration connectent F sorties du dernier étage de noeuds (N6) à chacun des M accès de sortie selon une configuration permettant un brassage parfait, F étant une puissance de deux, dans lequel chaque étage de l'ensemble d'étages de noeuds comprend le même nombre de noeuds, et dans lequel chacun des noeuds de l'ensemble d'étages de noeuds comporte deux entrées et deux sorties.
- 30 28. Un système selon la revendication 27, dans lequel les moyens de concentration comprennent  $\log_2 F$  étages (L6, N7, L7, N8) comprenant chacun un ensemble de noeuds ayant chacun deux entrées et une sortie.
- 35 29. Un système selon la revendication 1, dans lequel chacun des étages de noeuds comprend un ensemble (500, figure 8) de noeuds de commutation optiques ayant chacun au moins deux états optiques,  
des moyens pour recevoir a moins un réseau de faisceaux d'information comprenant de l'information à transmettre à travers le réseau, le ou les réseaux de faisceaux d'information correspondant à l'ensemble de noeuds de commutation,  
des moyens optiques en espace libre (100, 270, figure 93) pour diriger chaque faisceau d'information du ou des réseaux de faisceaux vers le noeud correspondant parmi les noeuds de commutation,  
des moyens pour générer un ensemble (DISABLE ou PRESET, figure 93) de signaux de commande indépendants des faisceaux d'information, et ayant chacun pour fonction de commander l'état optique de l'un correspondant des noeuds de commutation.
- 40 30. Un système selon la revendication 29, dans lequel les noeuds de commutation optiques sont des noeuds ayant une capacité égale à un.
- 45 31. Un système selon les revendications 29 ou 30, ce système comprenant des moyens optiques massifs et ne comprenant pas de moyens micro-optiques.
- 50 32. Un système selon la revendication 1, dans lequel chacun des étages de noeuds comprend un ensemble (500, figure 58) de noeuds de commutation optiques de capacité égale à un, ayant chacun au moins deux états optiques.
- 55 33. Un système selon les revendications 1 ou 32, ce système comprenant des moyens optiques massifs et ne comprenant pas de moyens micro-optiques.
34. Un système selon la revendication 1, qui est du type sans blocage.

35. Un système selon la revendication 1, qui a une probabilité de blocage arbitrairement faible, dépendant de F et du nombre d'étages de noeuds et d'étages de mailles.

5

10

15

20

25

30

35

40

45

50

55



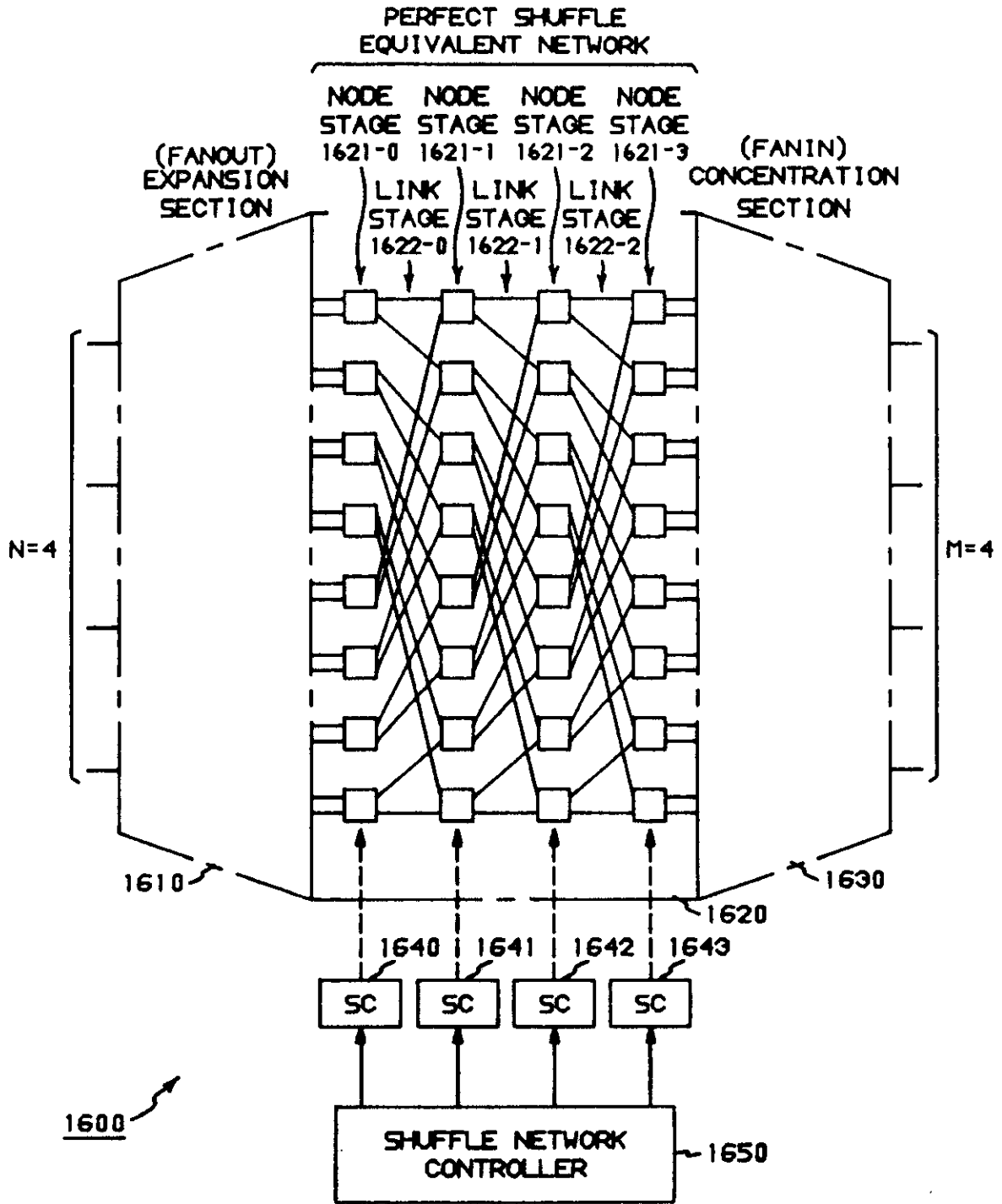

FIG. 2

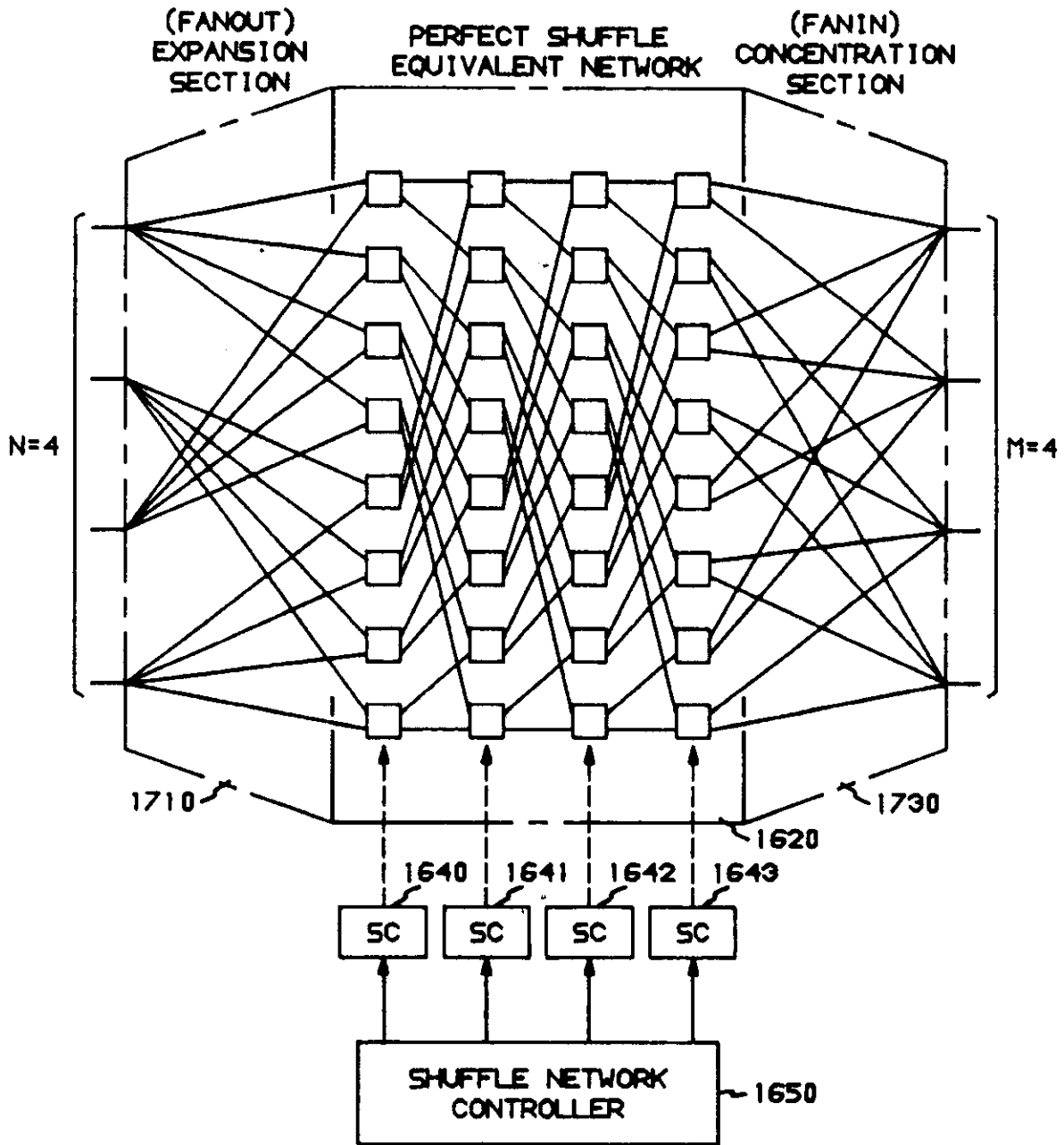

FIG. 3

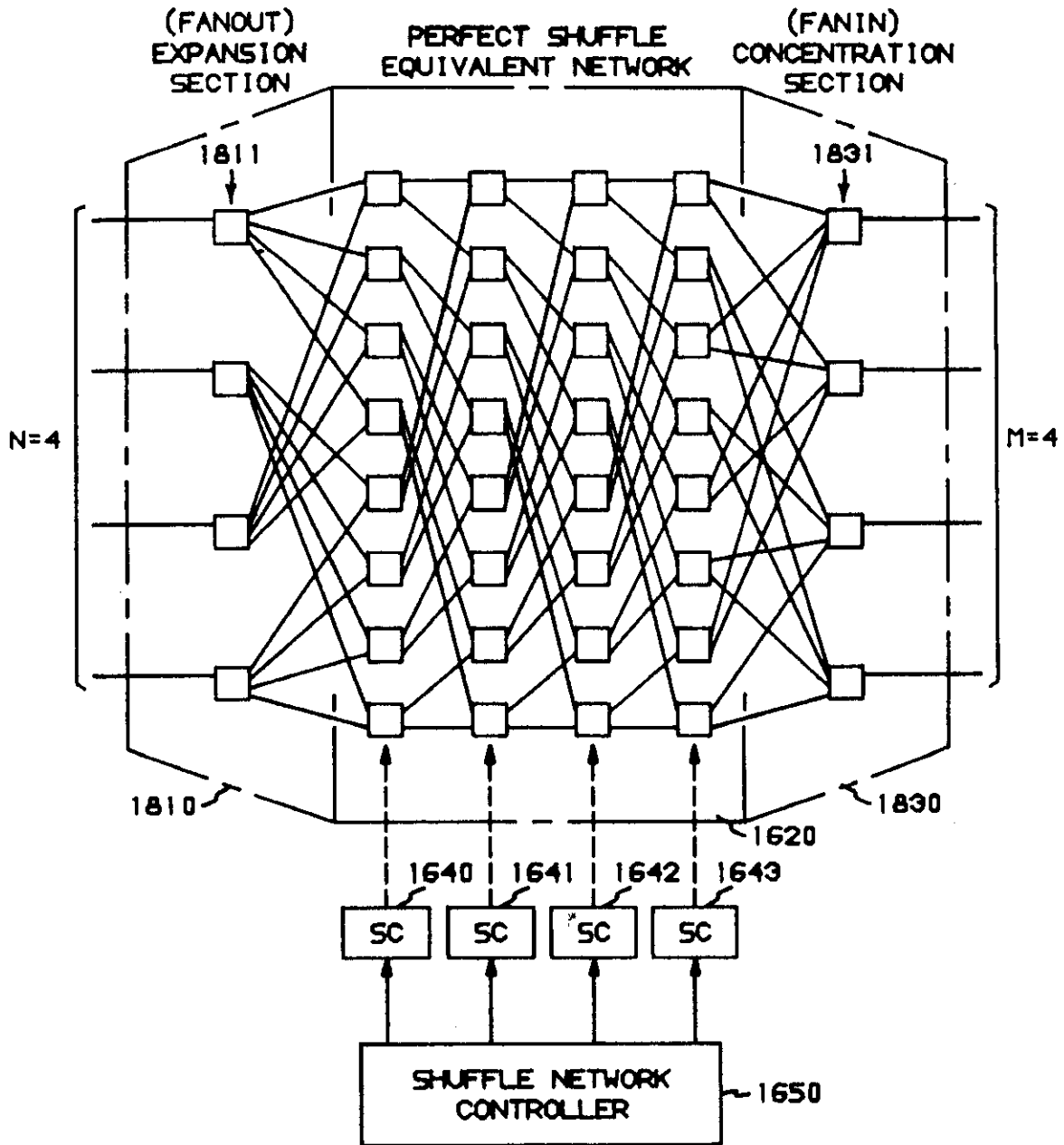

FIG. 4

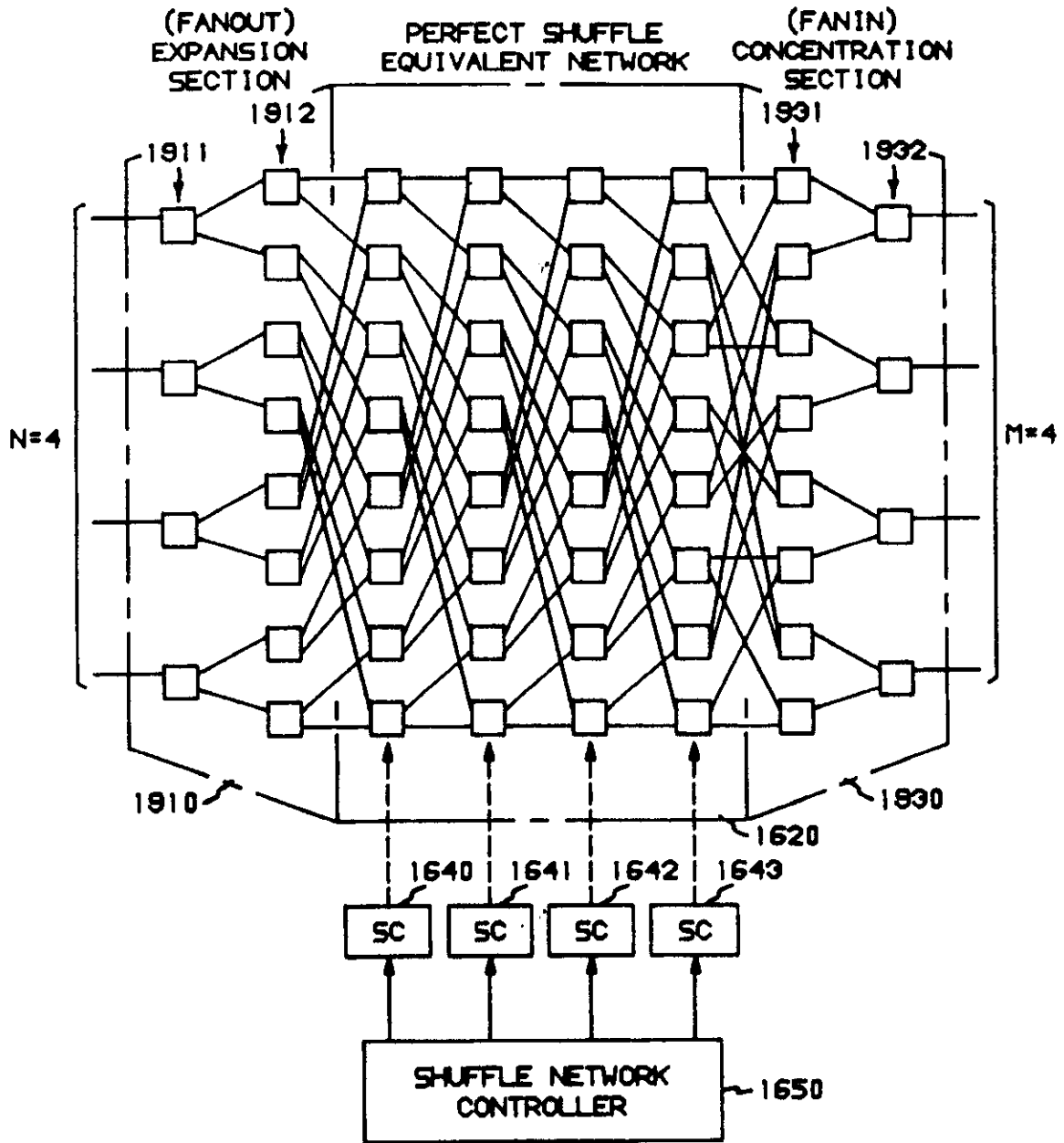
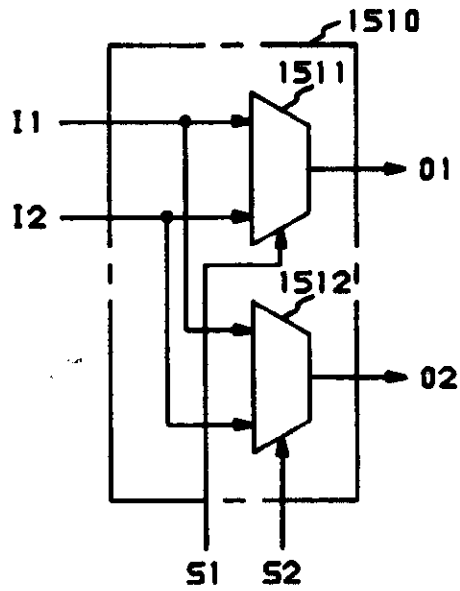
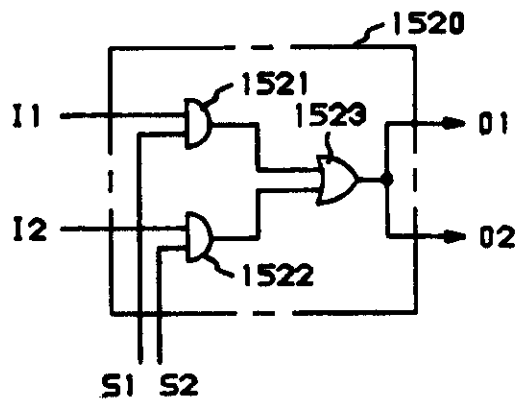

FIG. 5

**FIG. 6**  
FULL CAPACITY  
NODE



**FIG. 7**  
CAPACITY ONE  
NODE  
WITH SELECTIVITY



**FIG. 8**  
CAPACITY ONE  
NODE  
WITHOUT SELECTIVITY

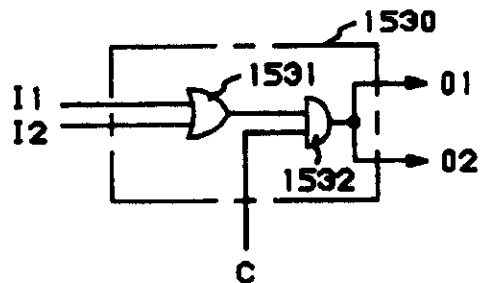

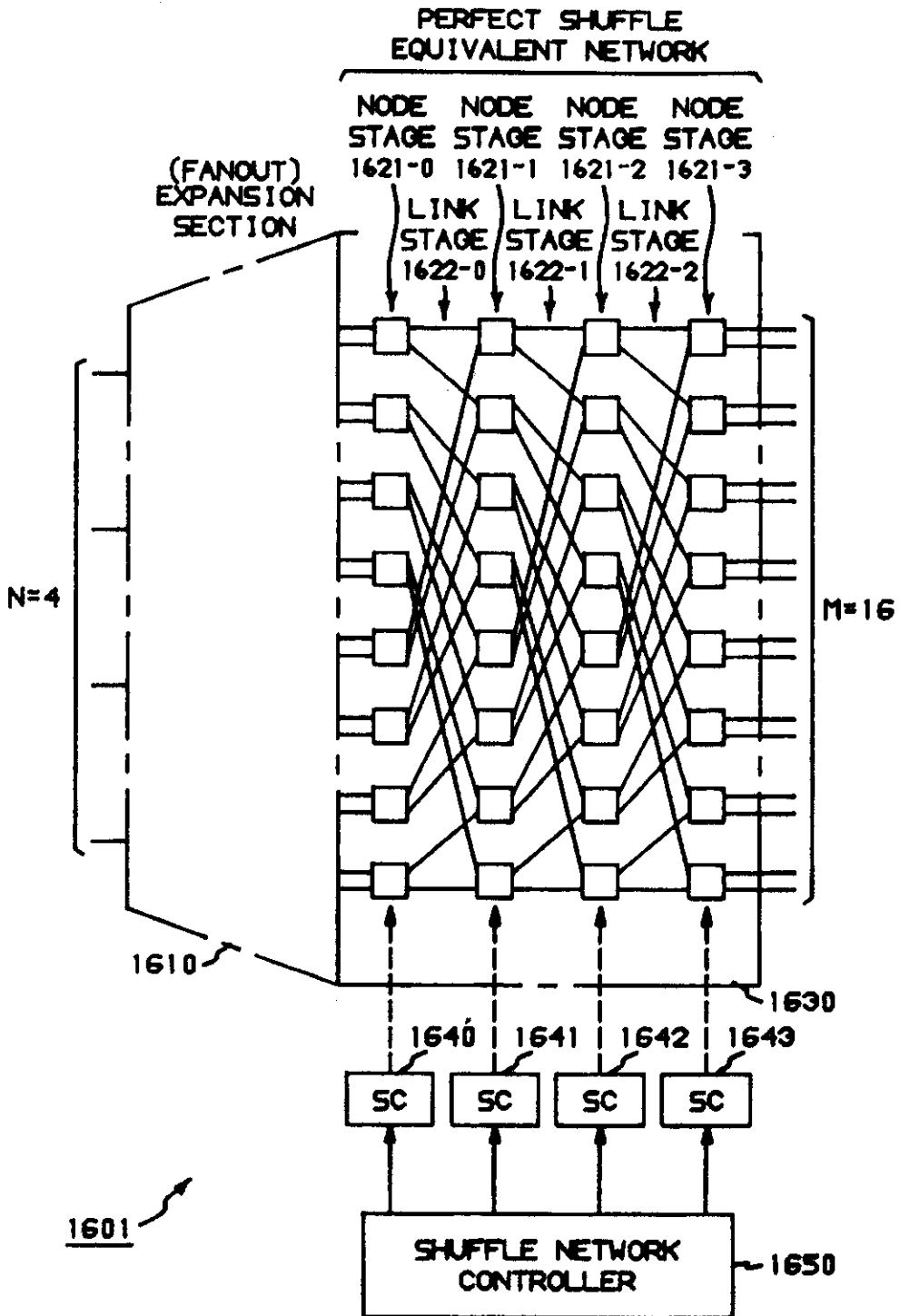

FIG. 9

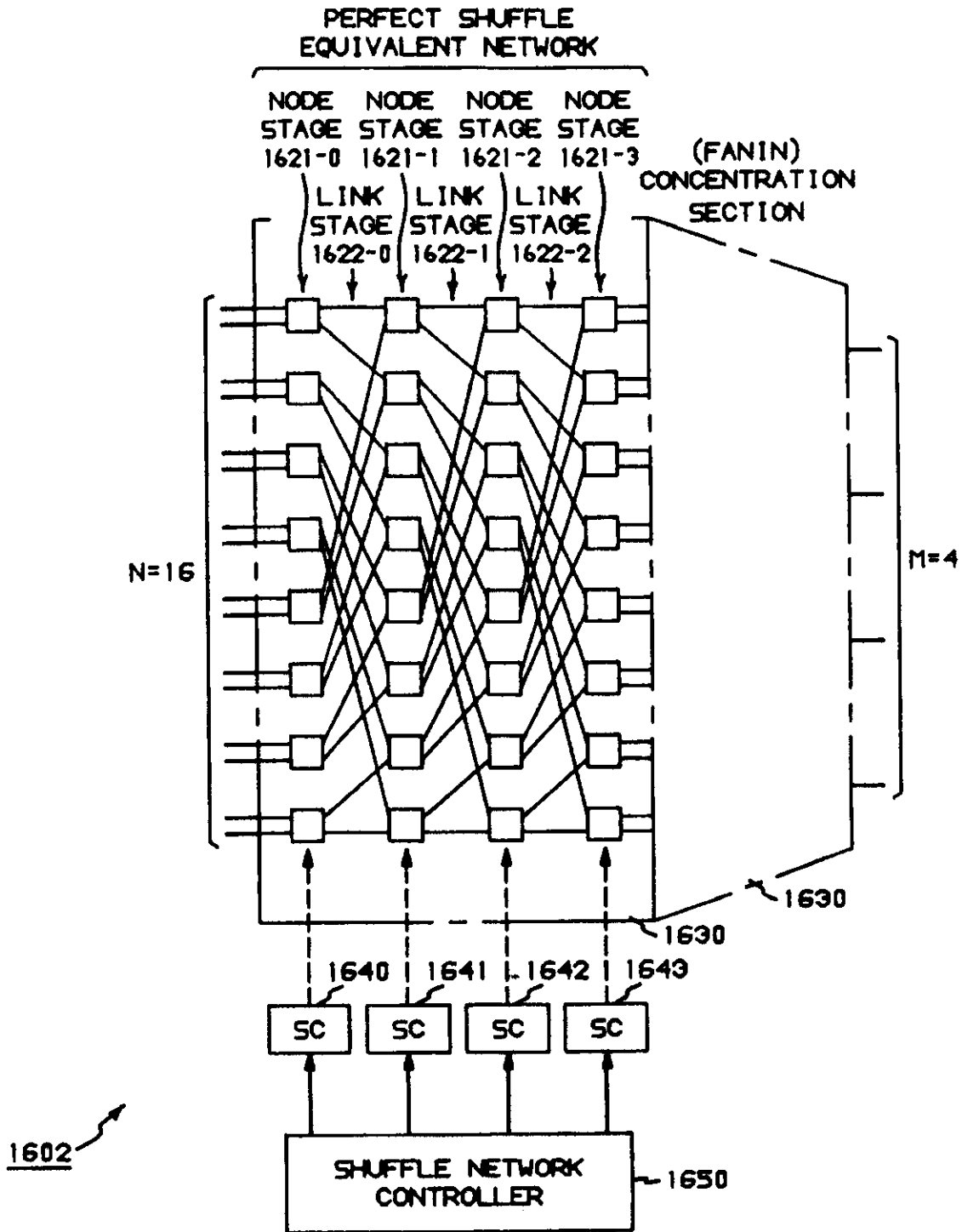

FIG. 10

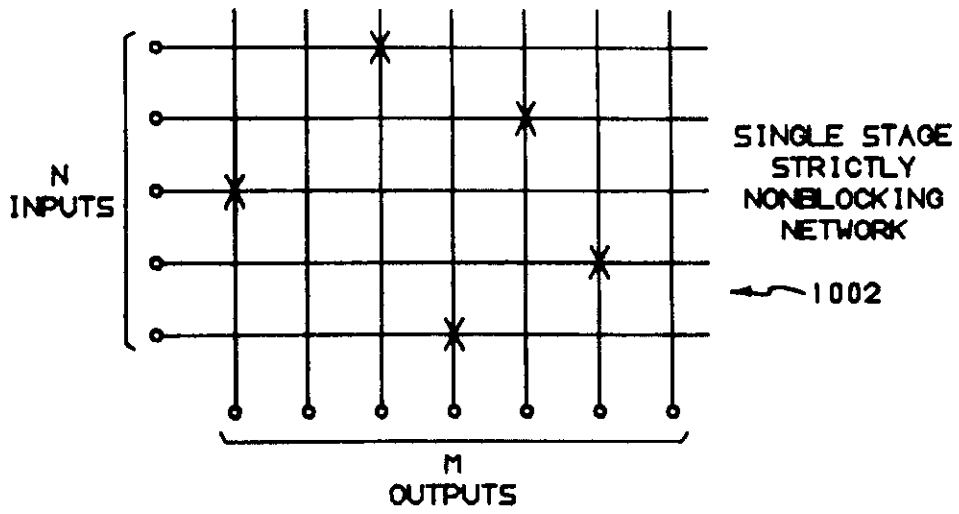

FIG. 11

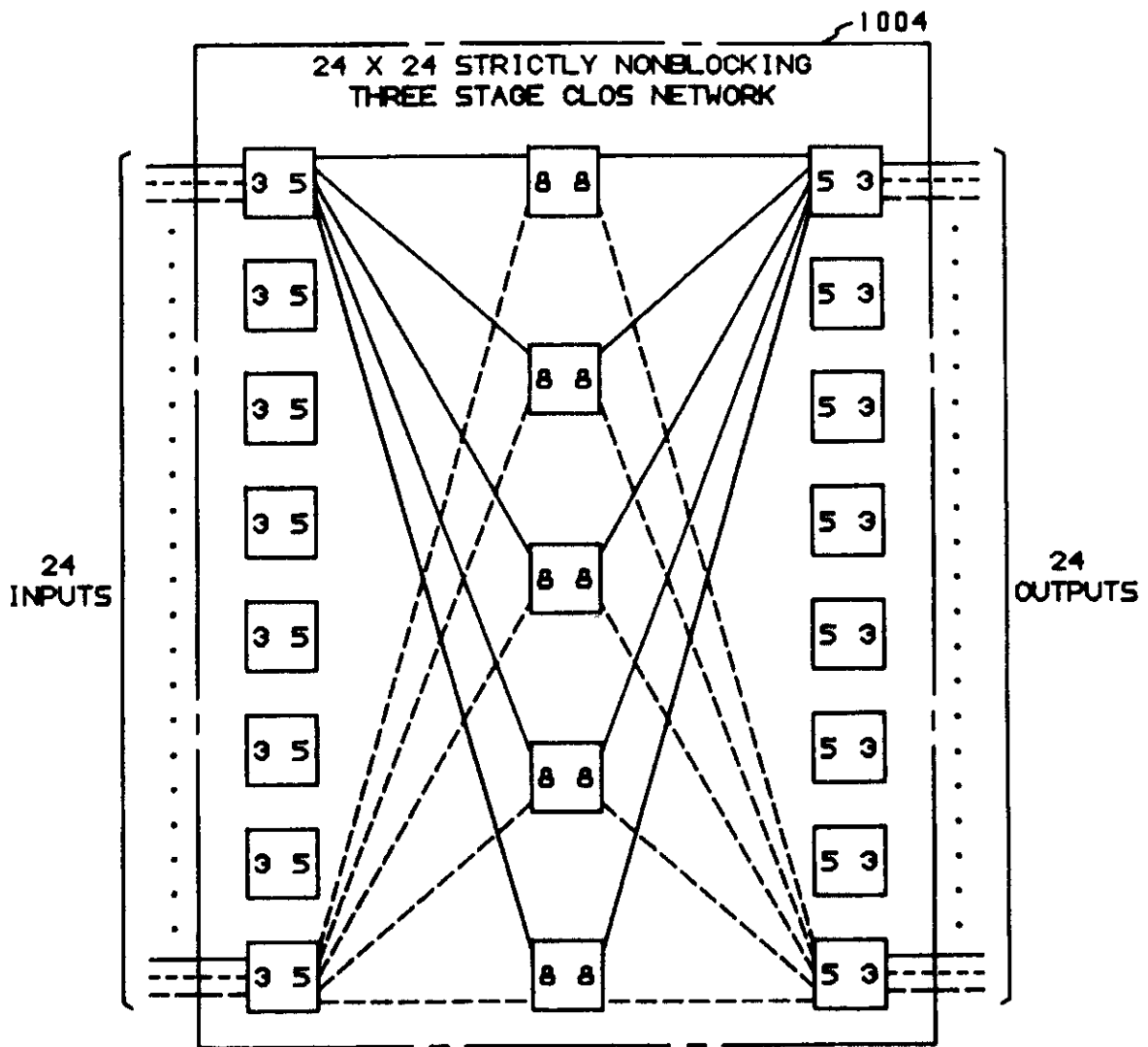
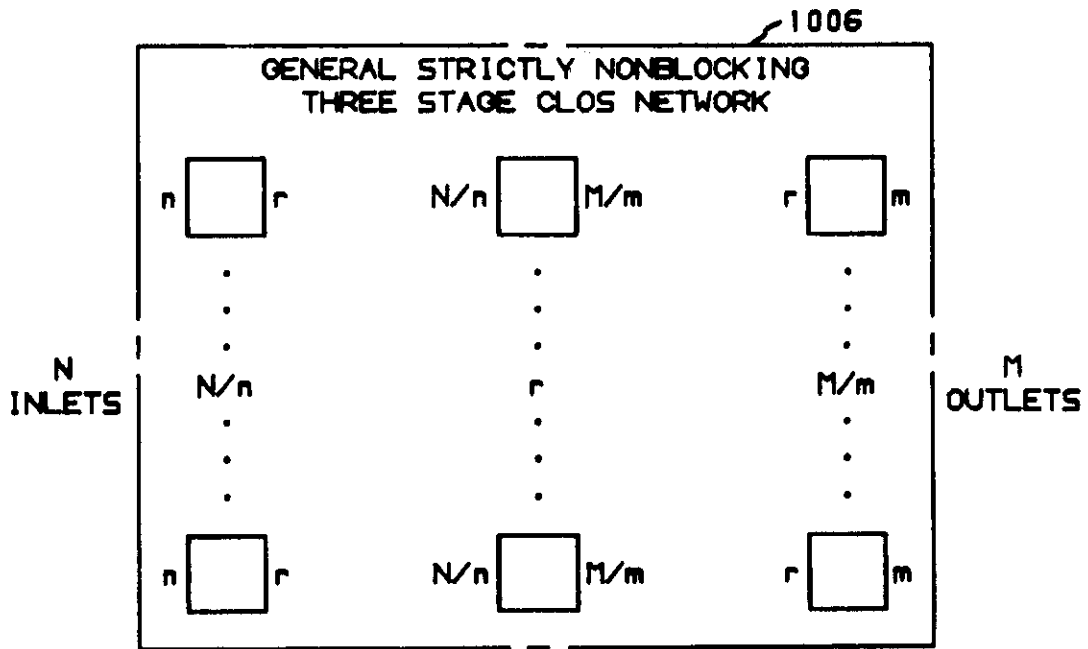

FIG. 12



**FIG. 13**

1008

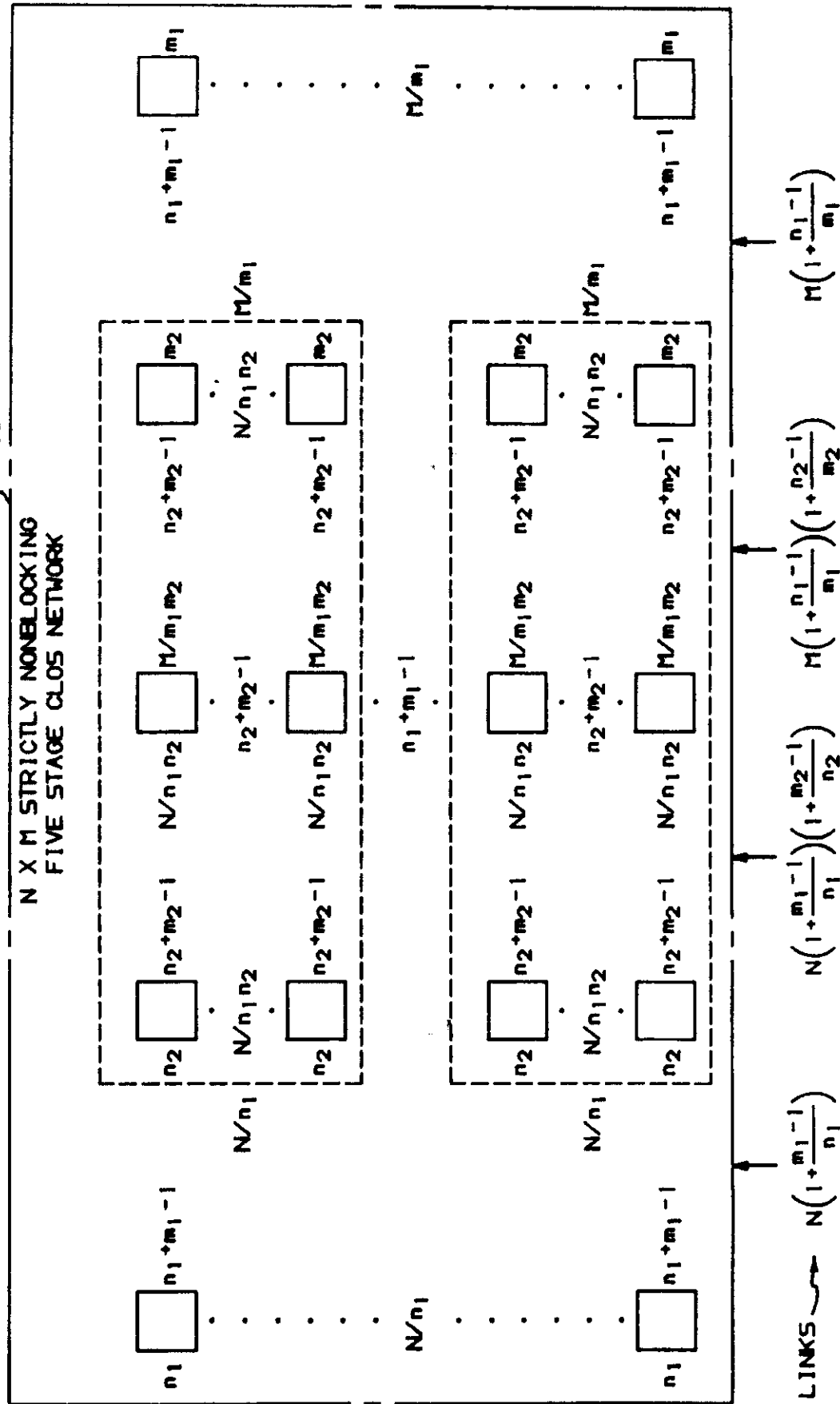
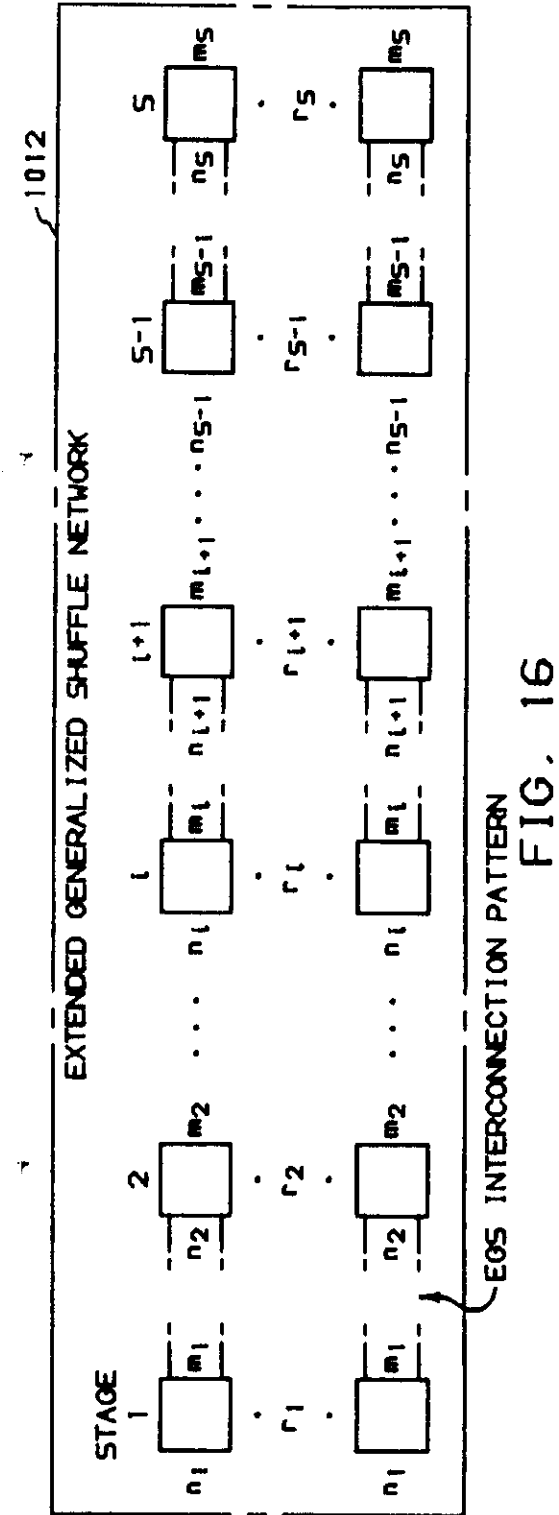
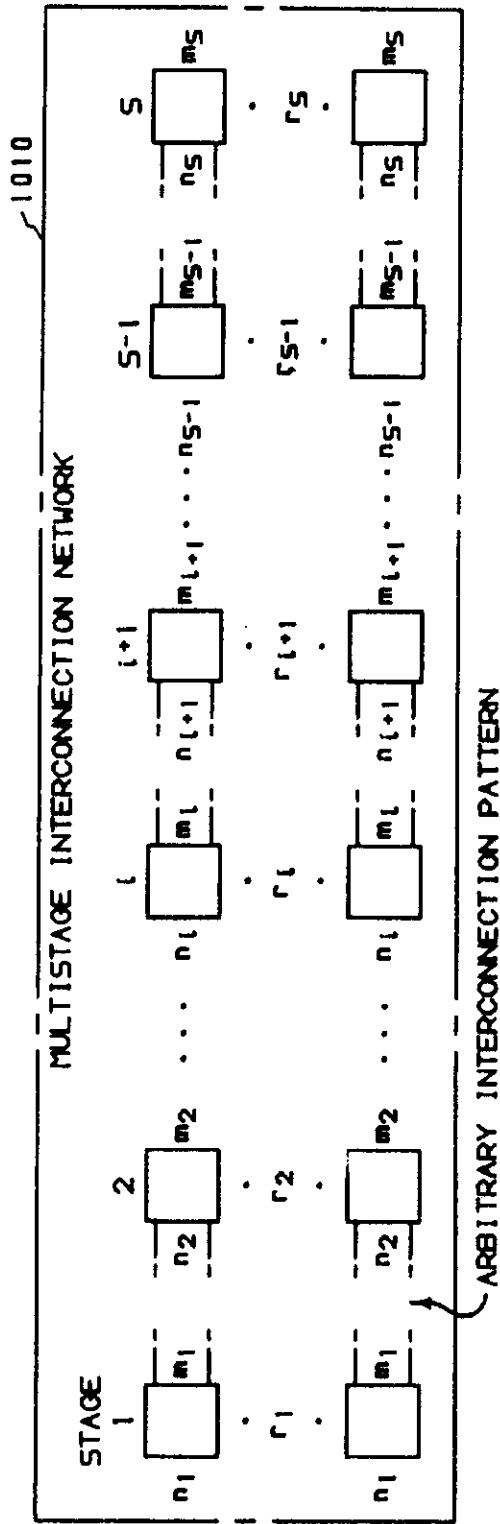

FIG. 14



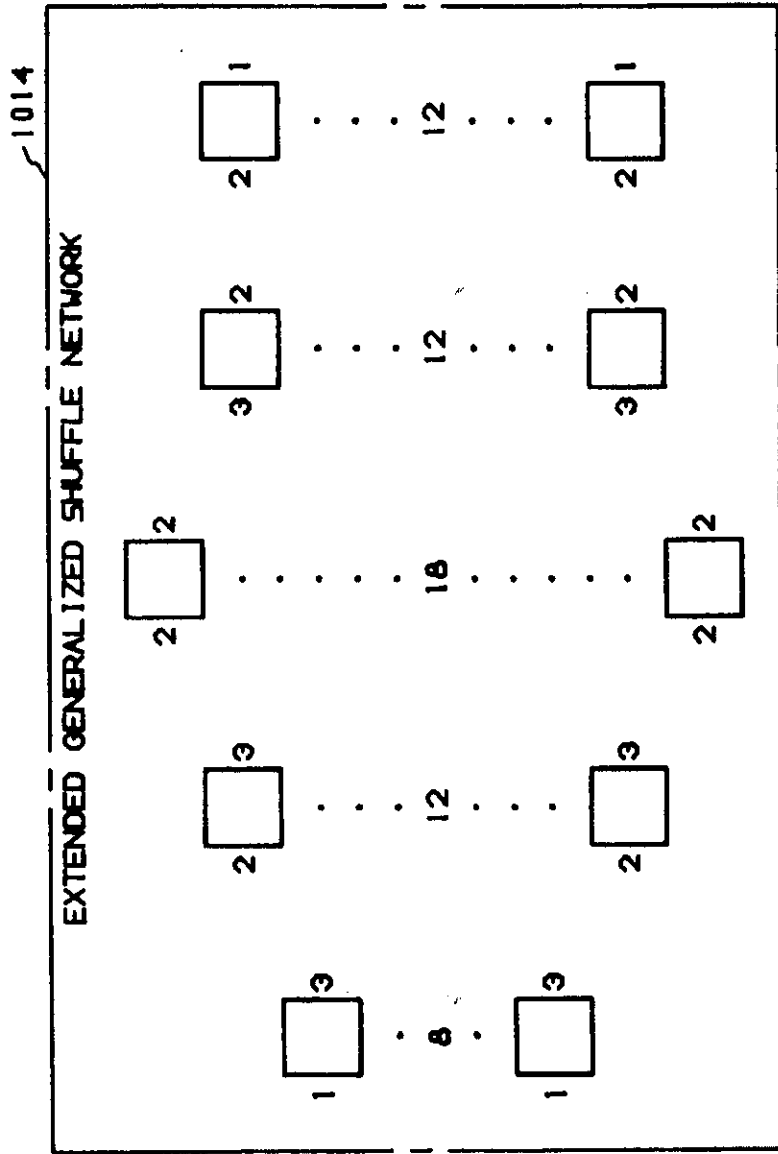

FIG. 17

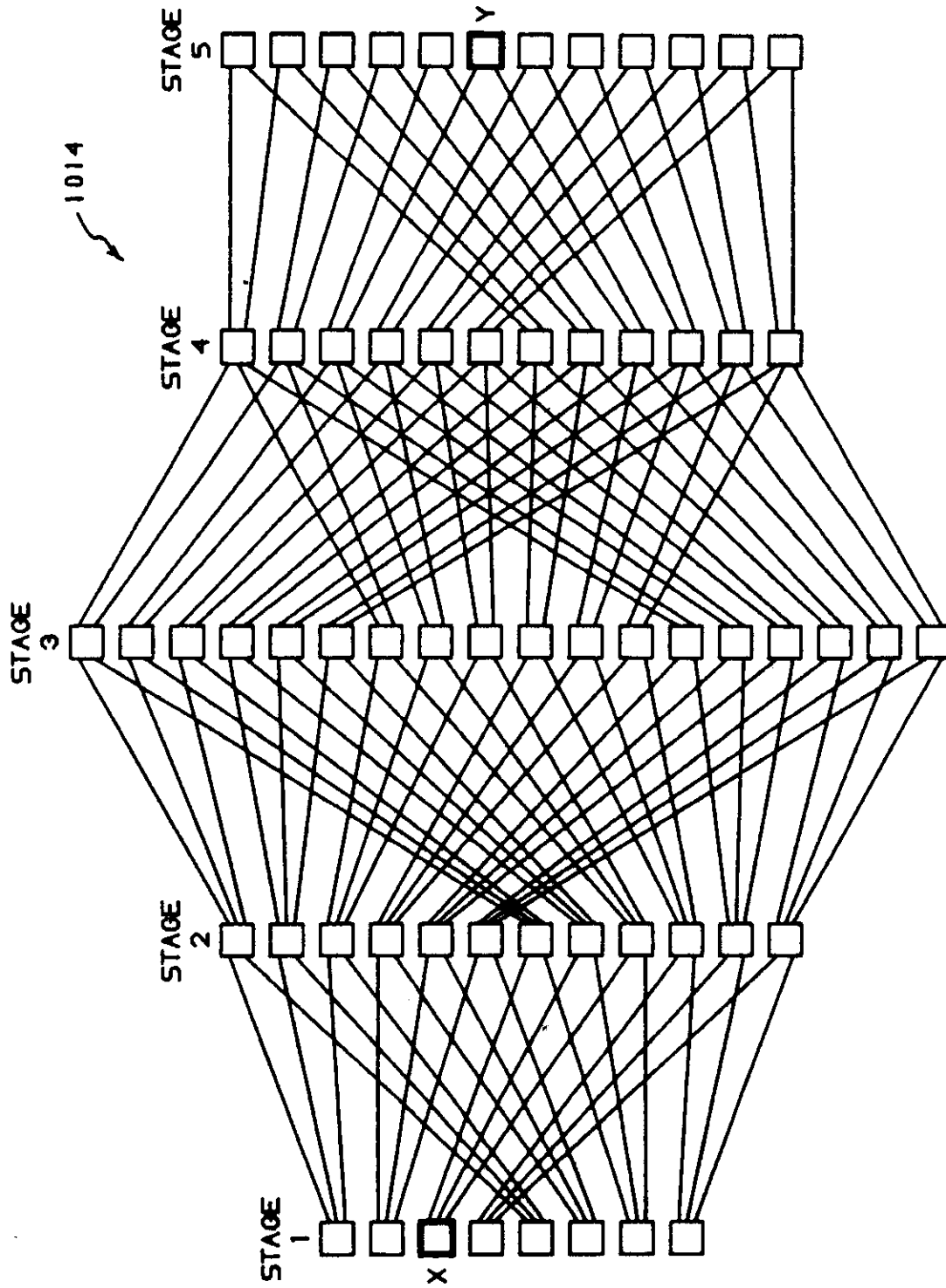

FIG. 18

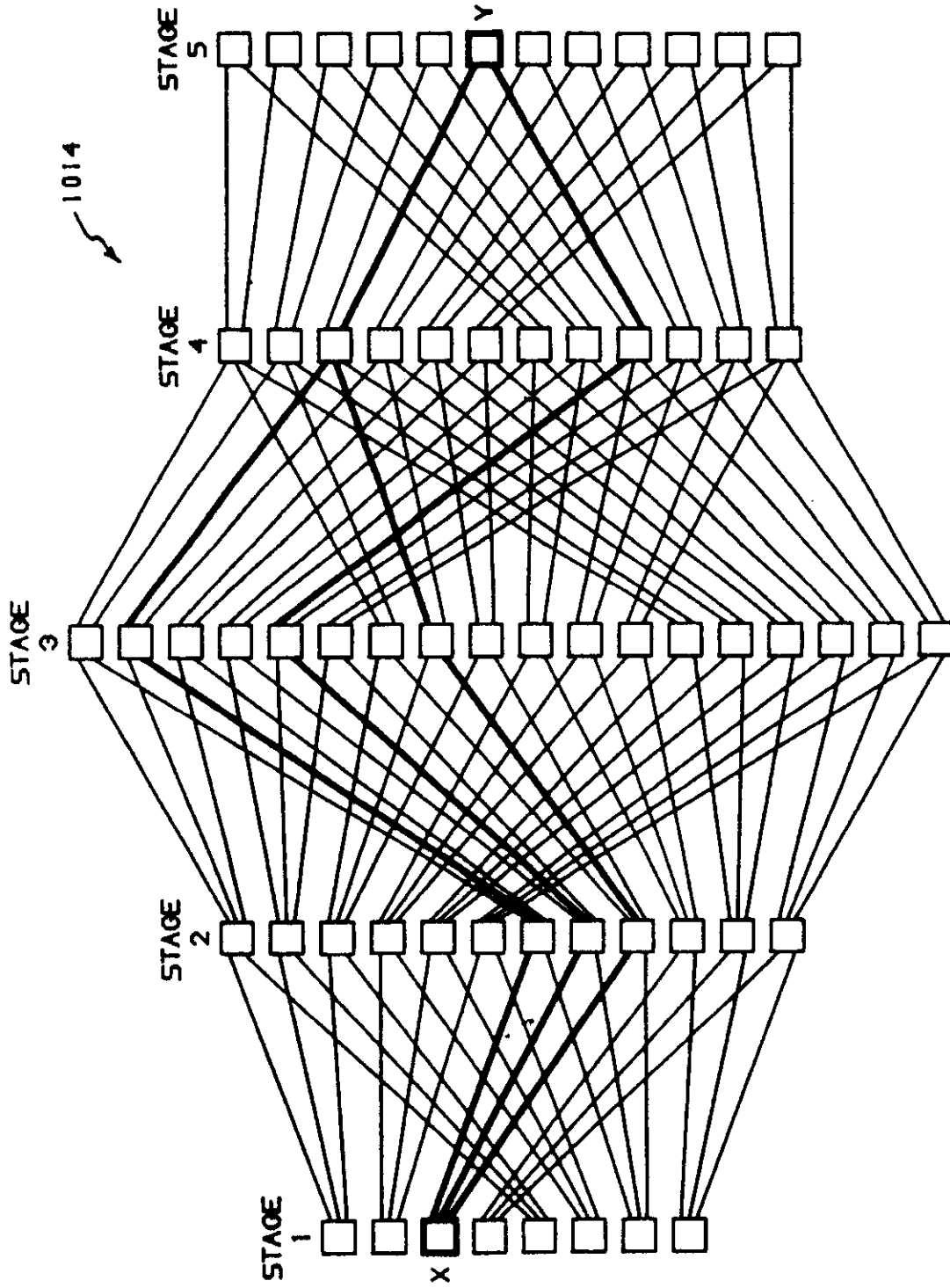

FIG. 19

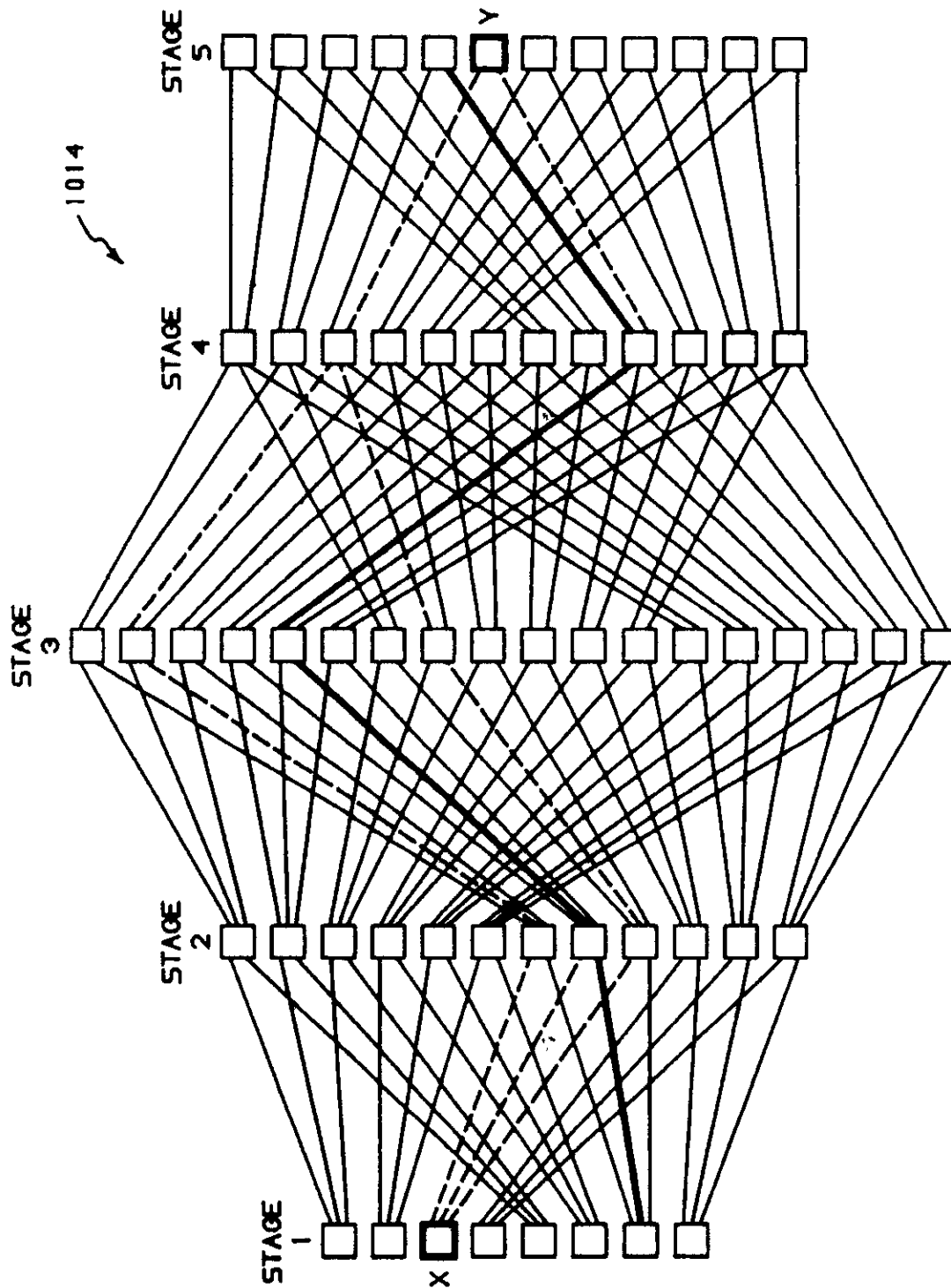

FIG. 20

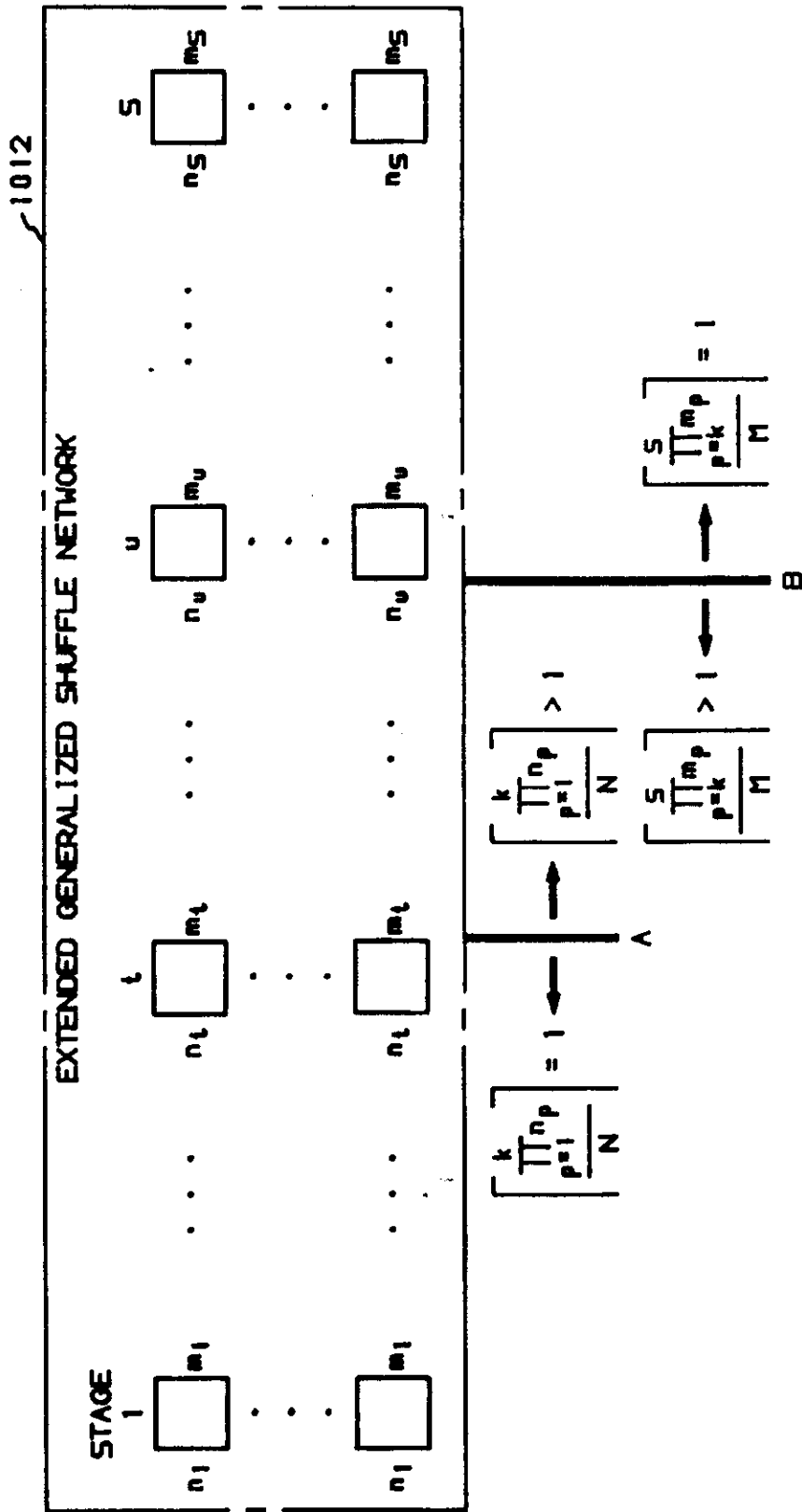

FIG. 21

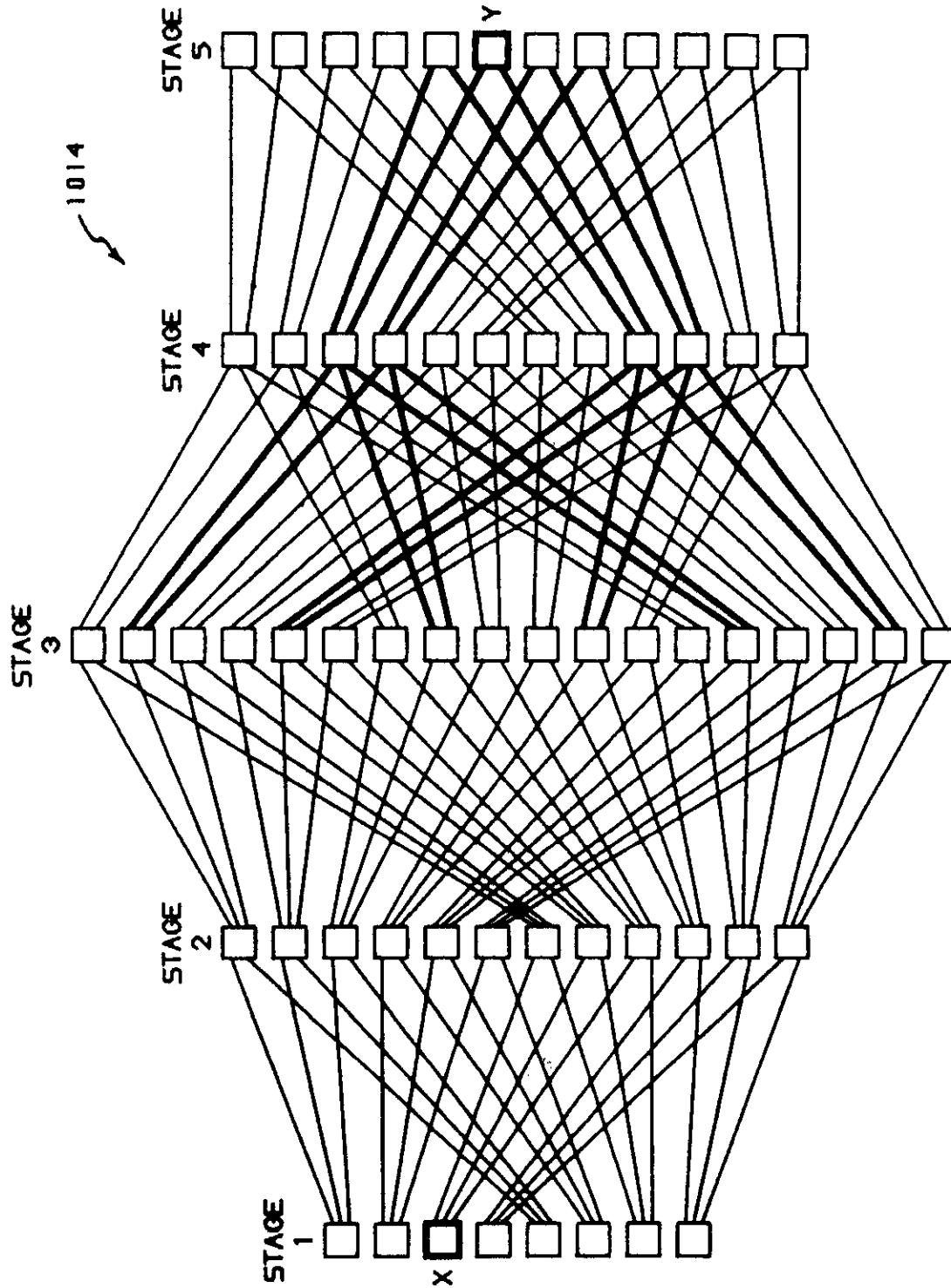

FIG. 22

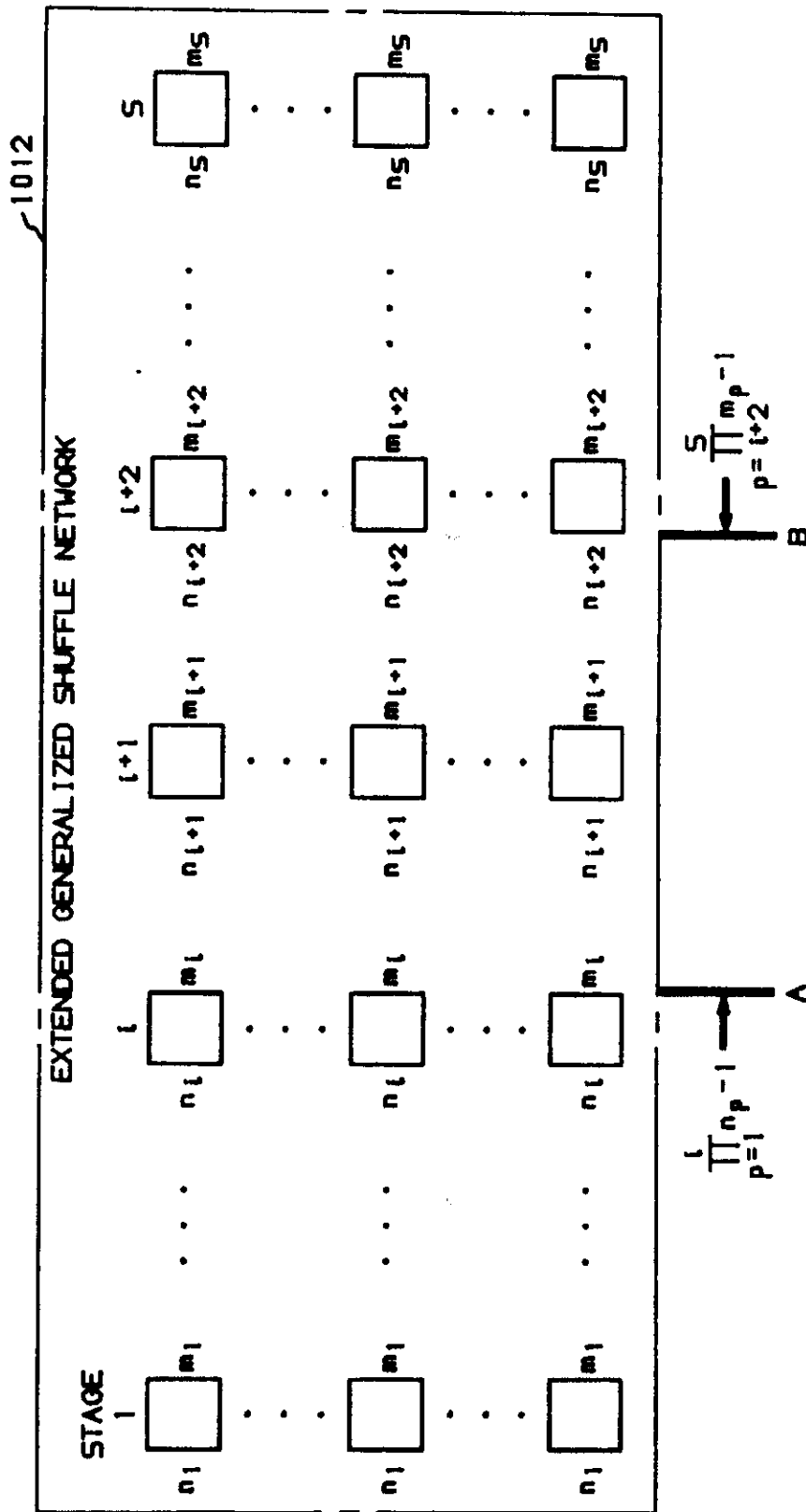

FIG. 23

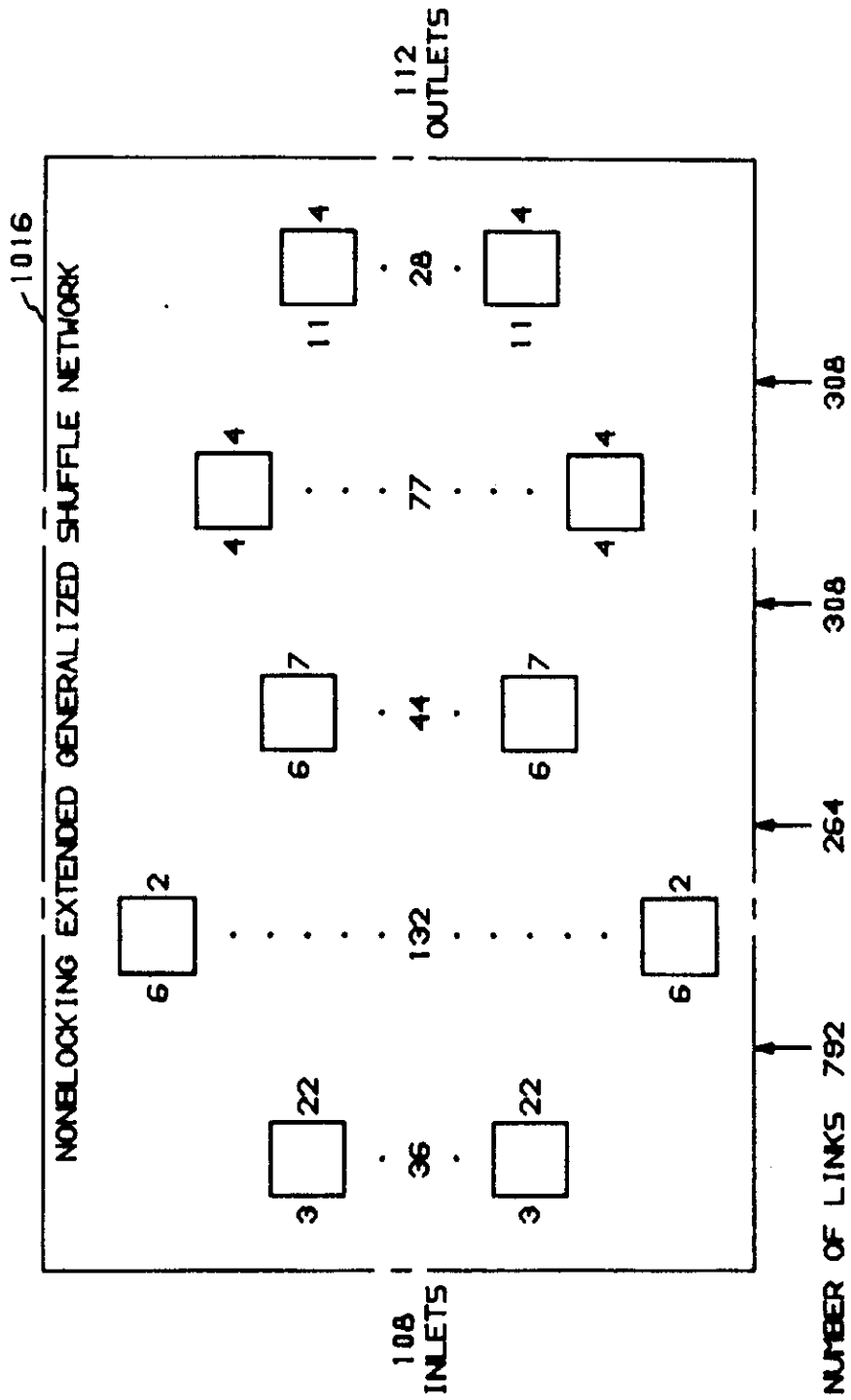

FIG. 24

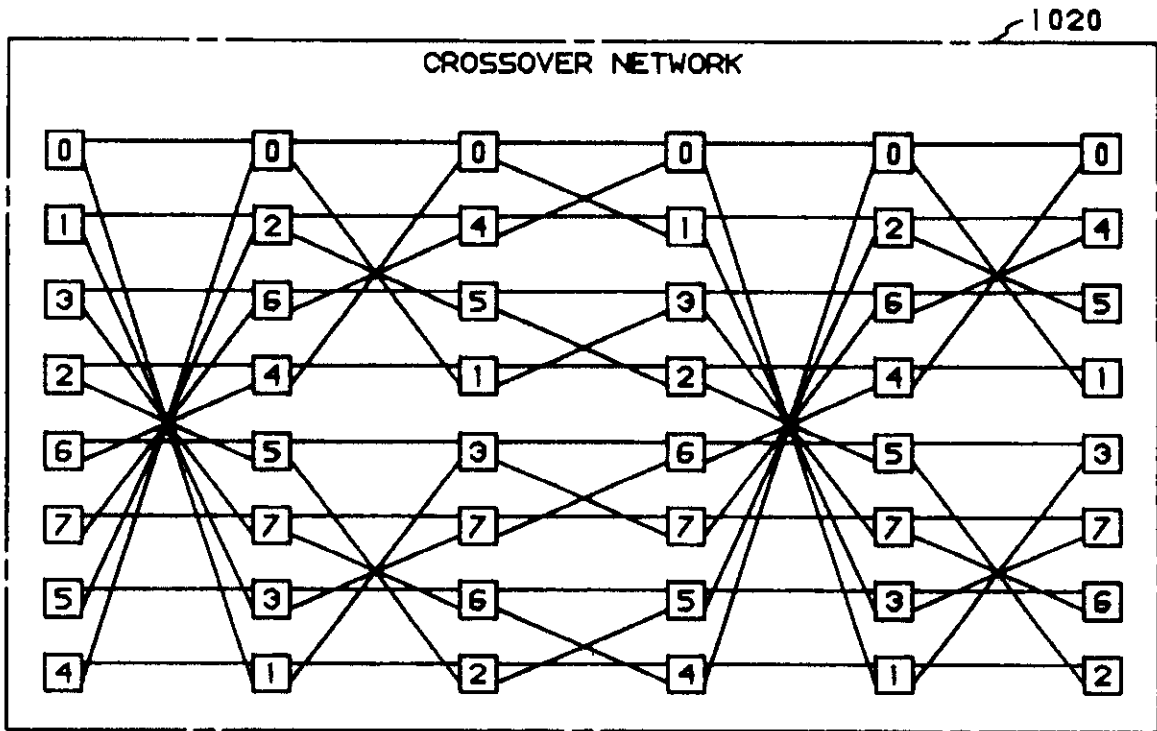

FIG. 25

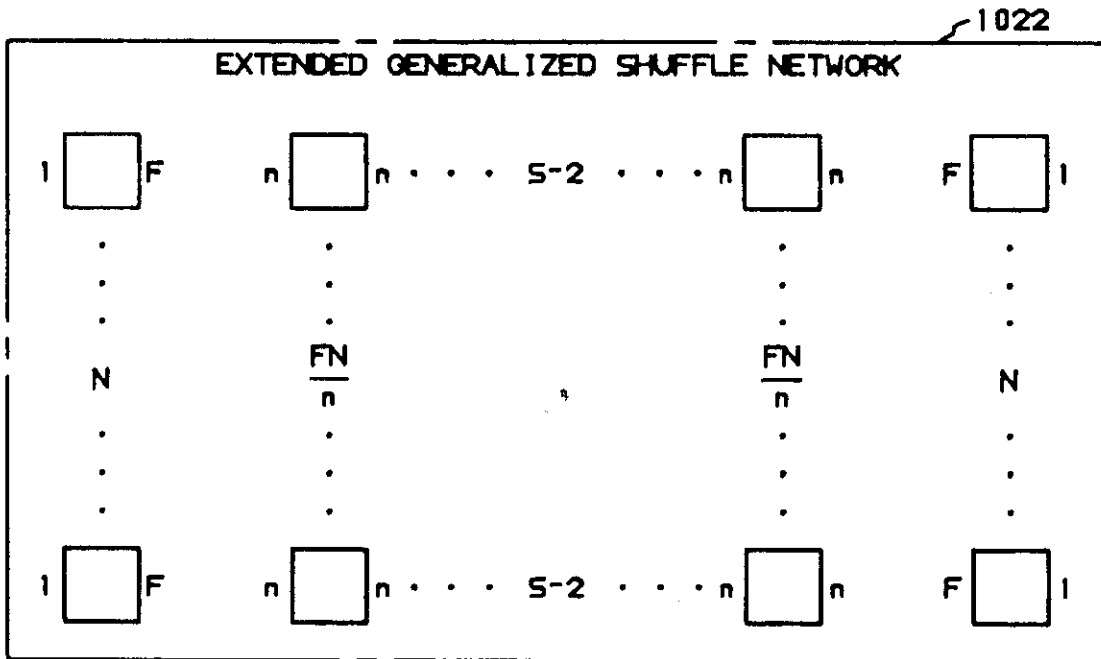

FIG. 26

FIG. 27

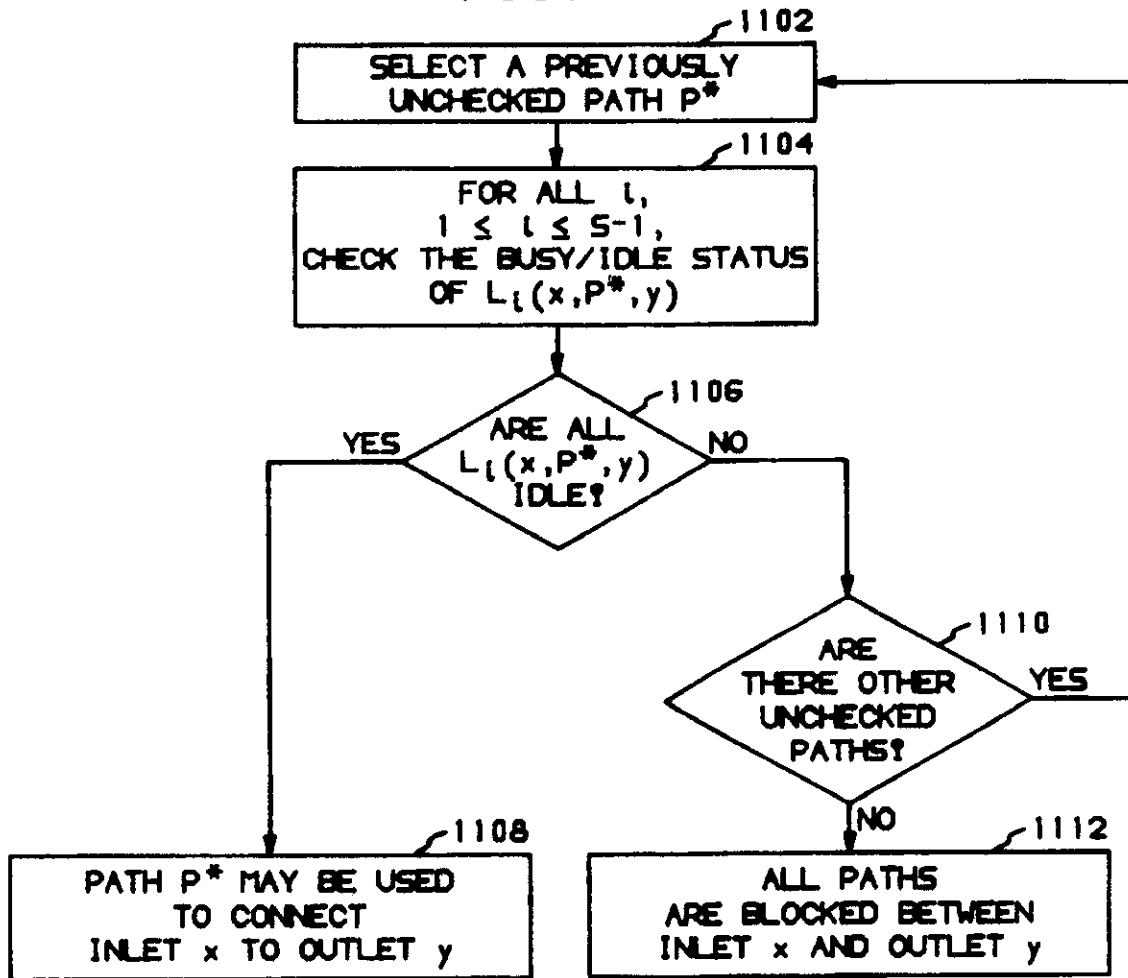
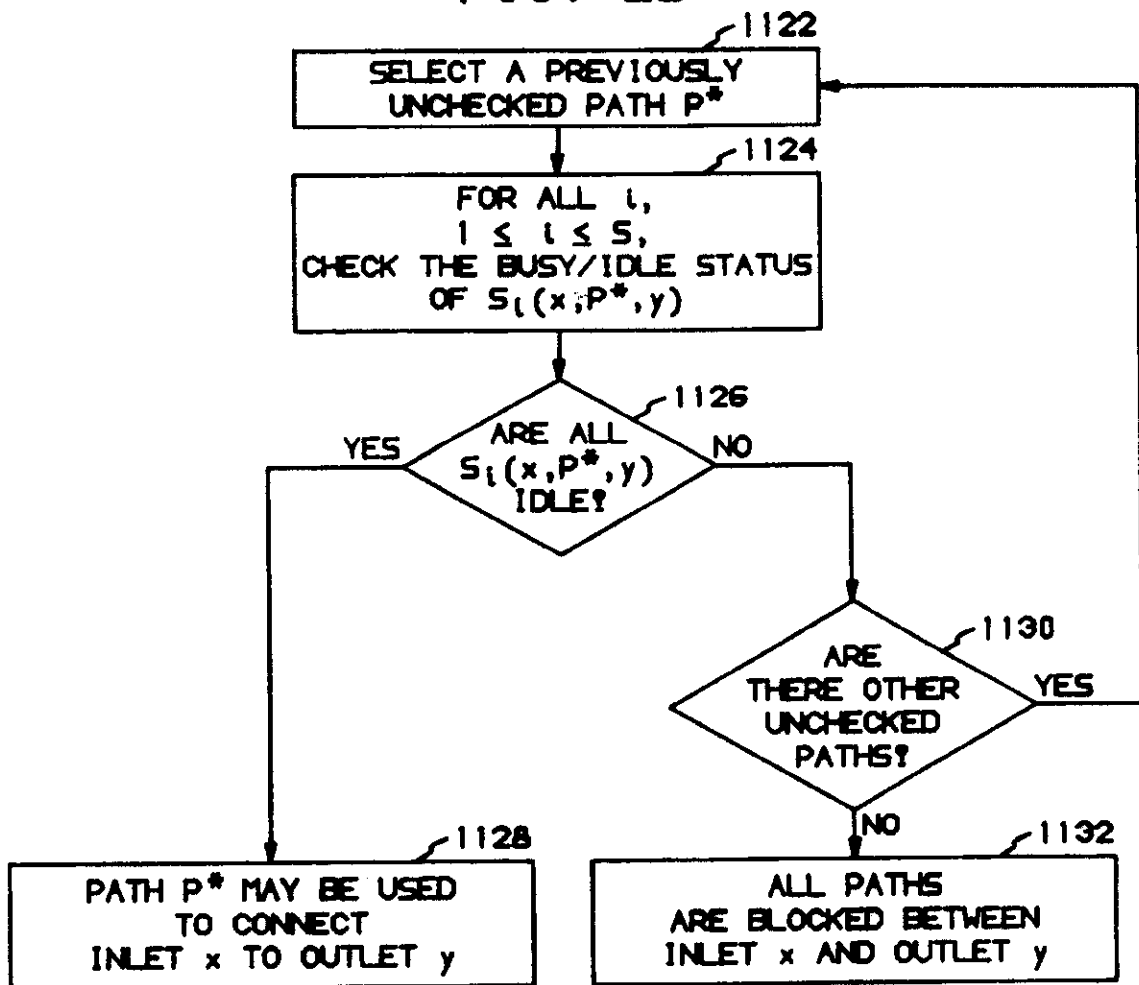

FIG. 28



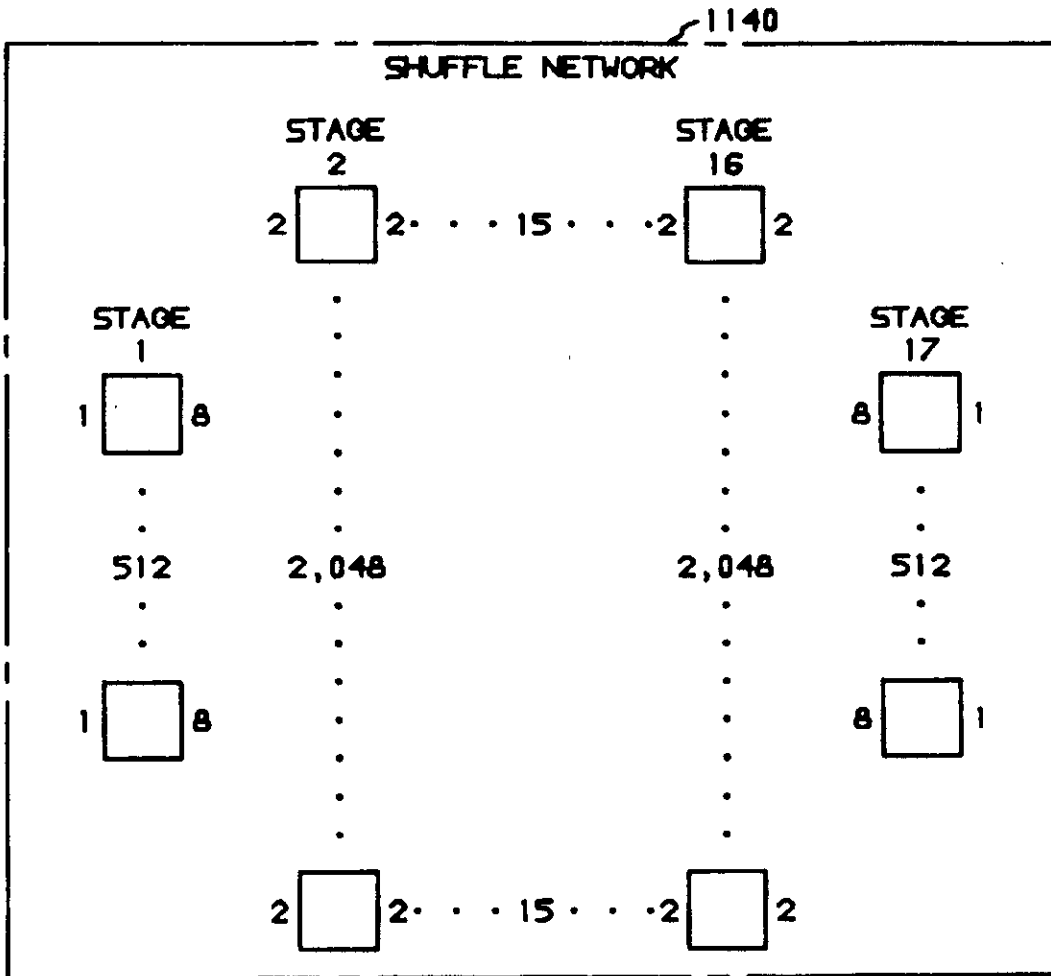

FIG. 29



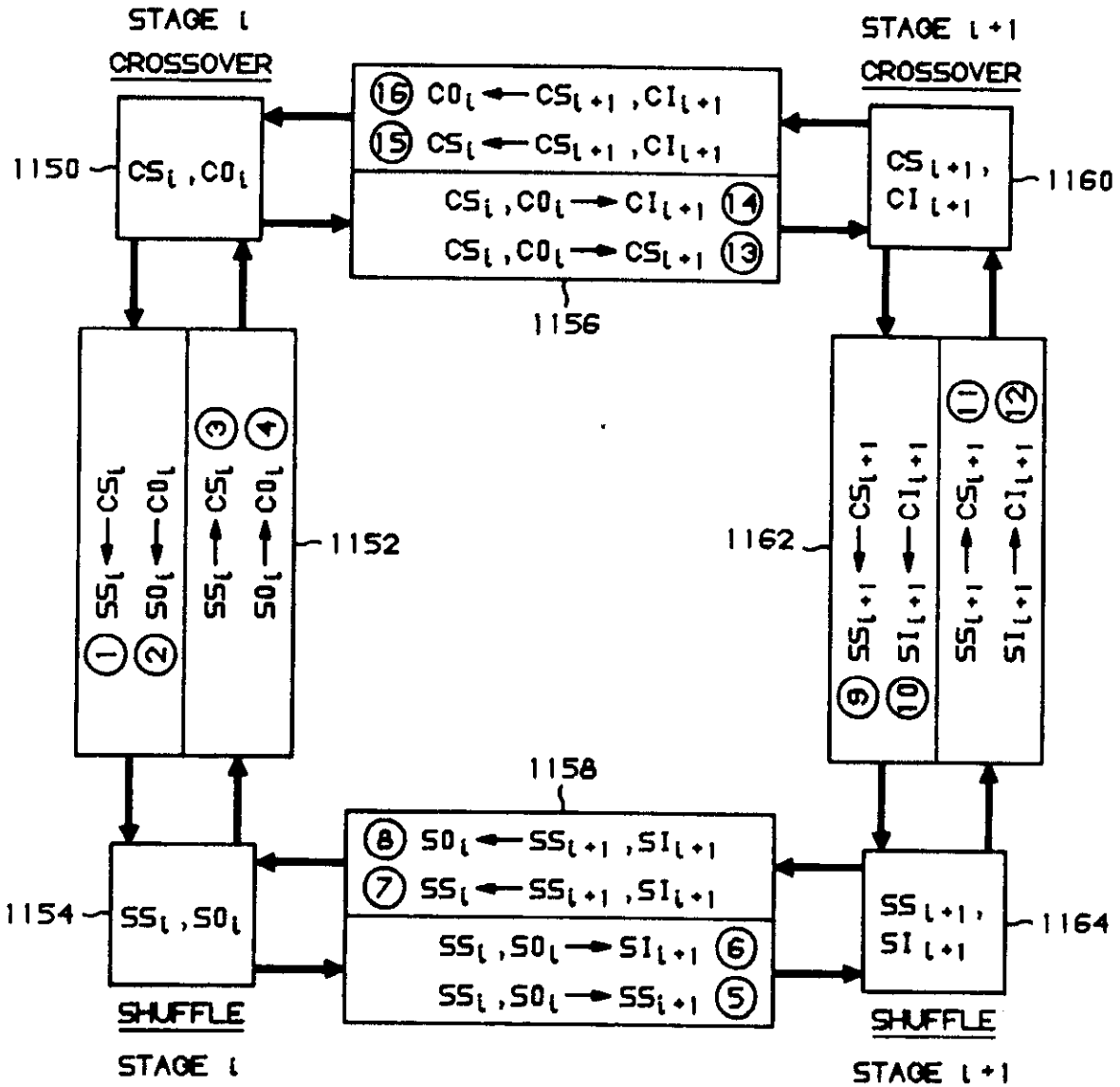
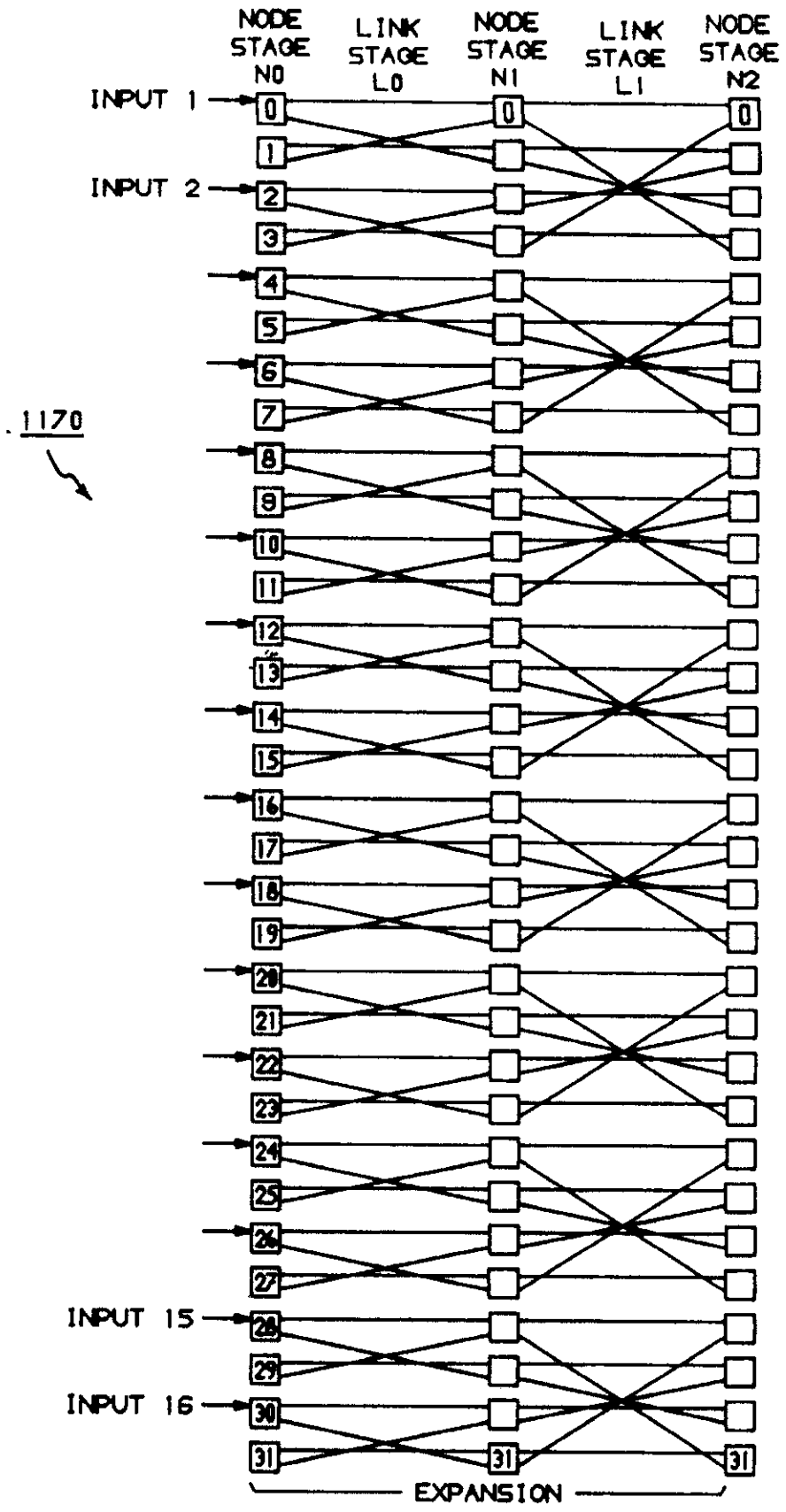

FIG. 32



16 X 16  
CROSSOVER  
NETWORK

FIG. 34	FIG. 35	FIG. 36
------------	------------	------------

FIG. 33

FIG. 34

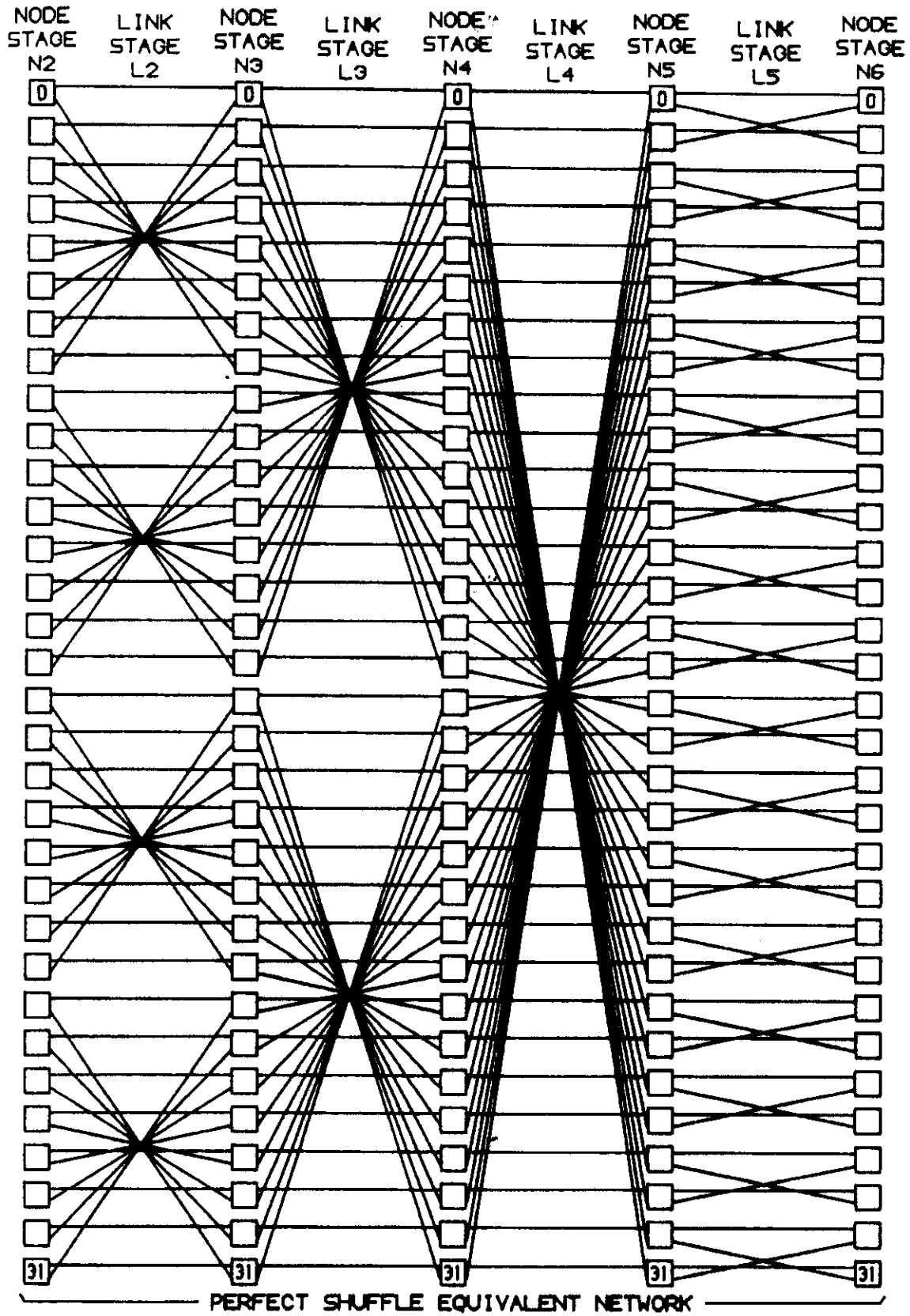

FIG. 35

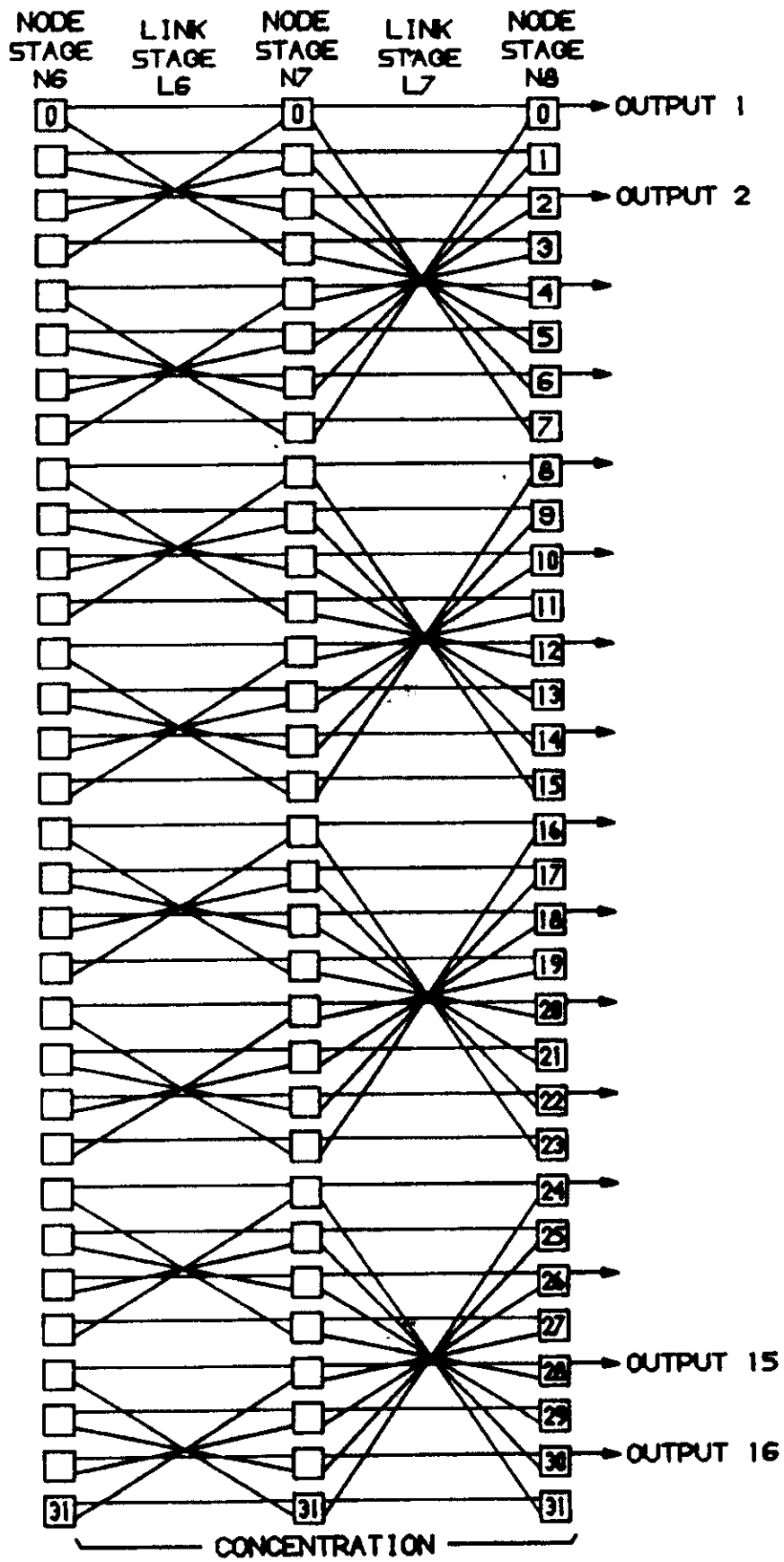

FIG. 36

RELATIVE SIZES OF NETWORKS

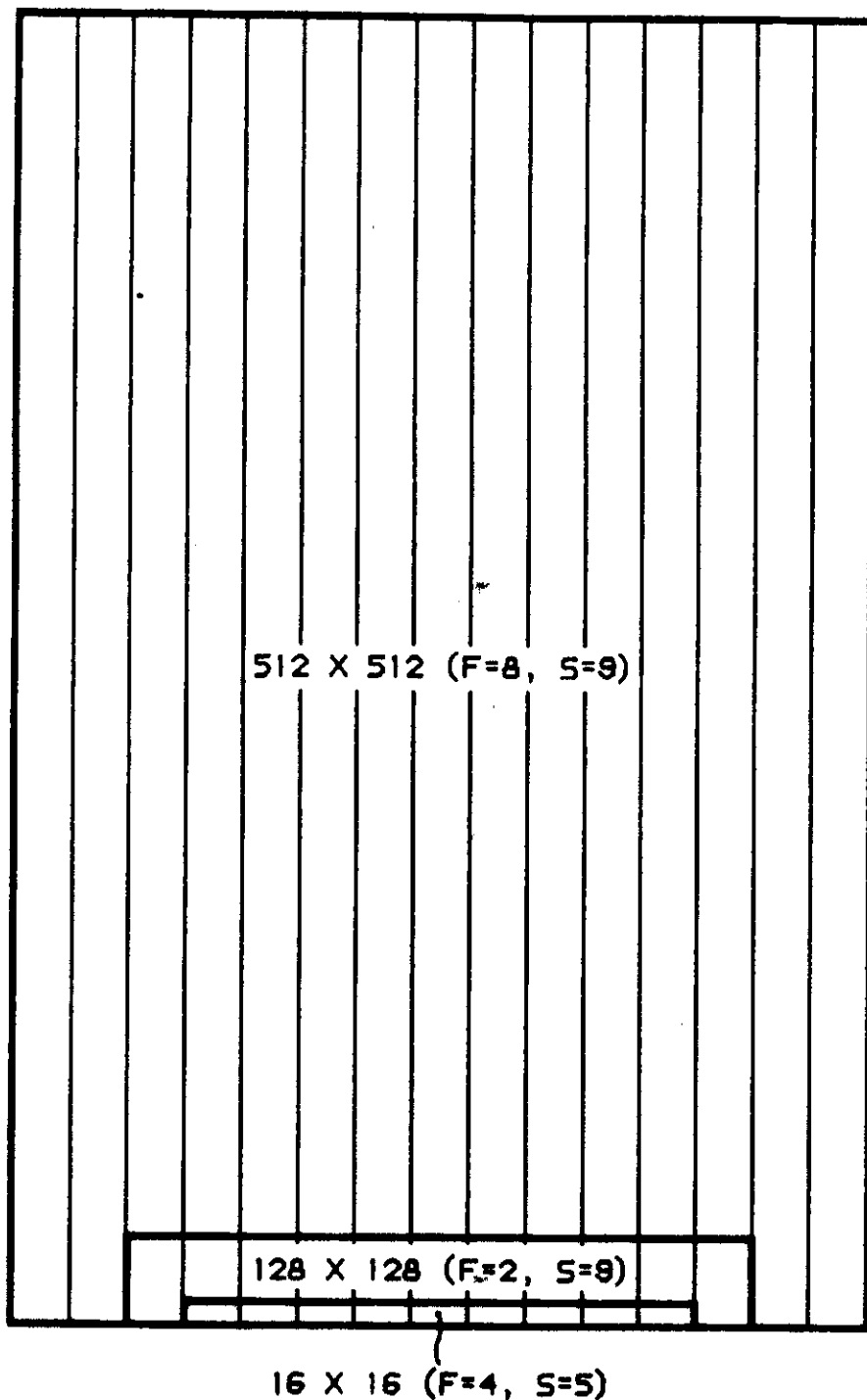

FIG. 37

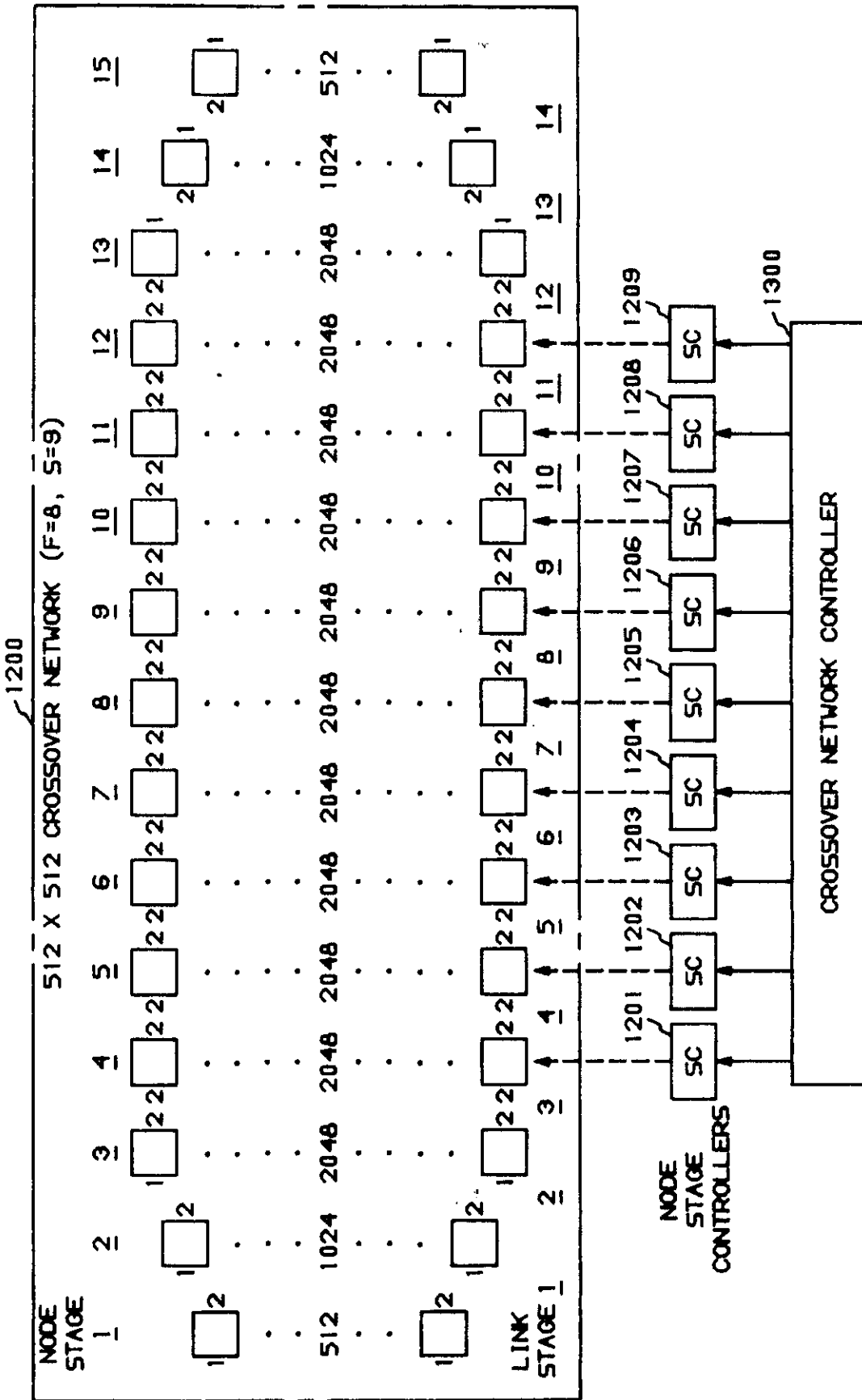

FIG. 38

FIG. 39

CROSSOVER NETWORK CONNECTION REQUEST

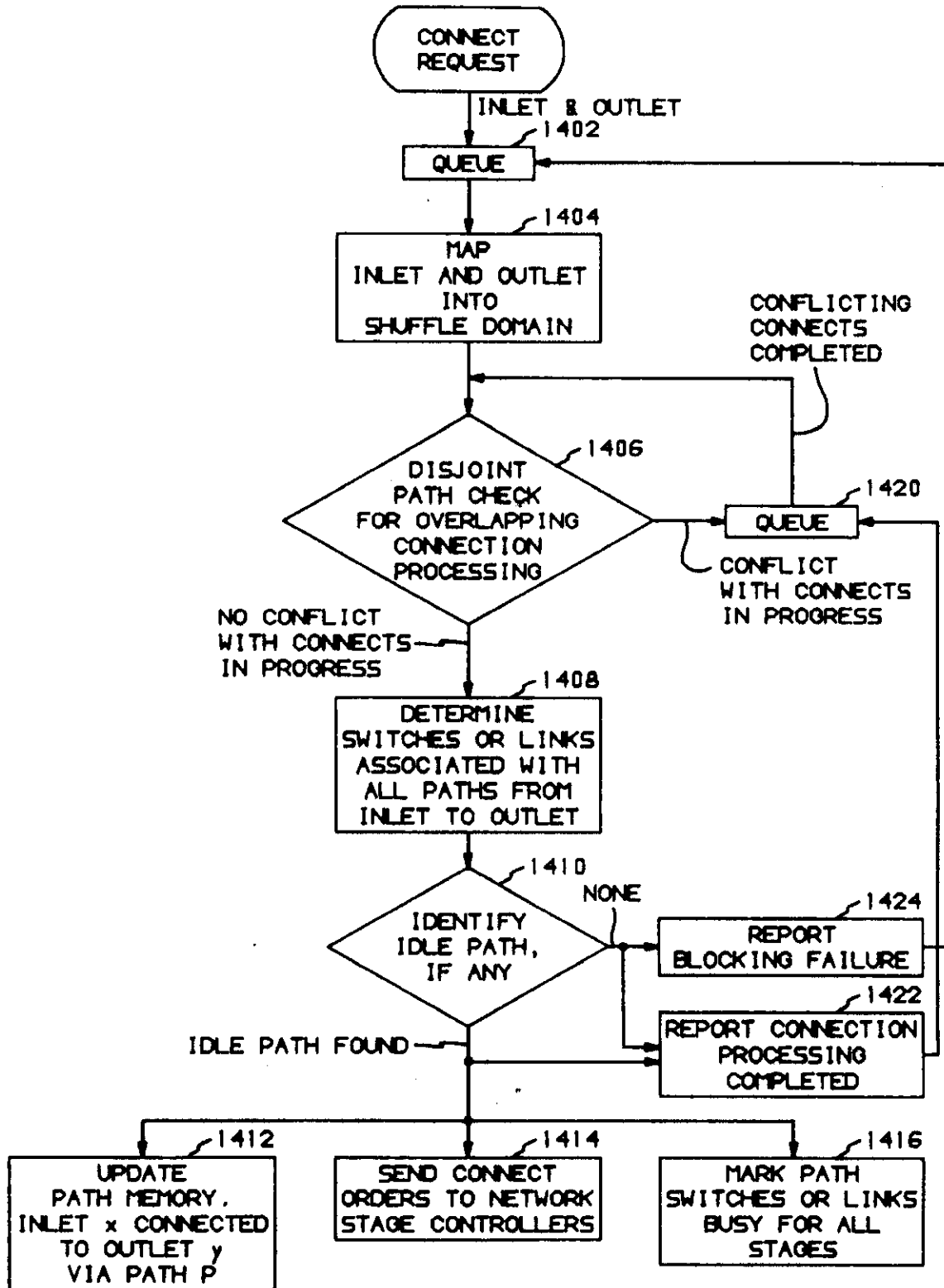
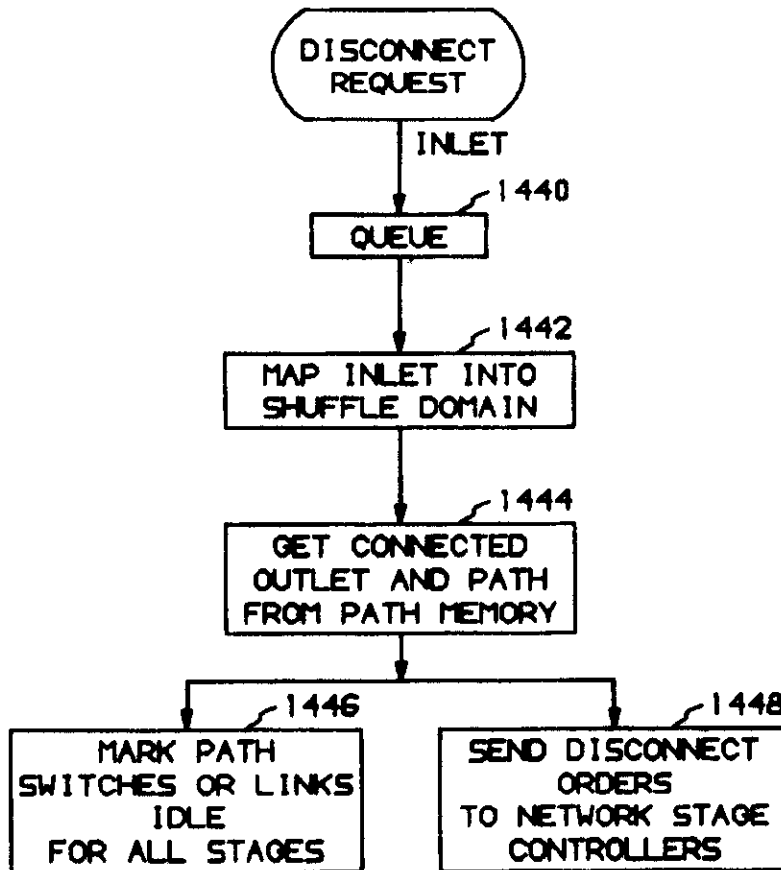
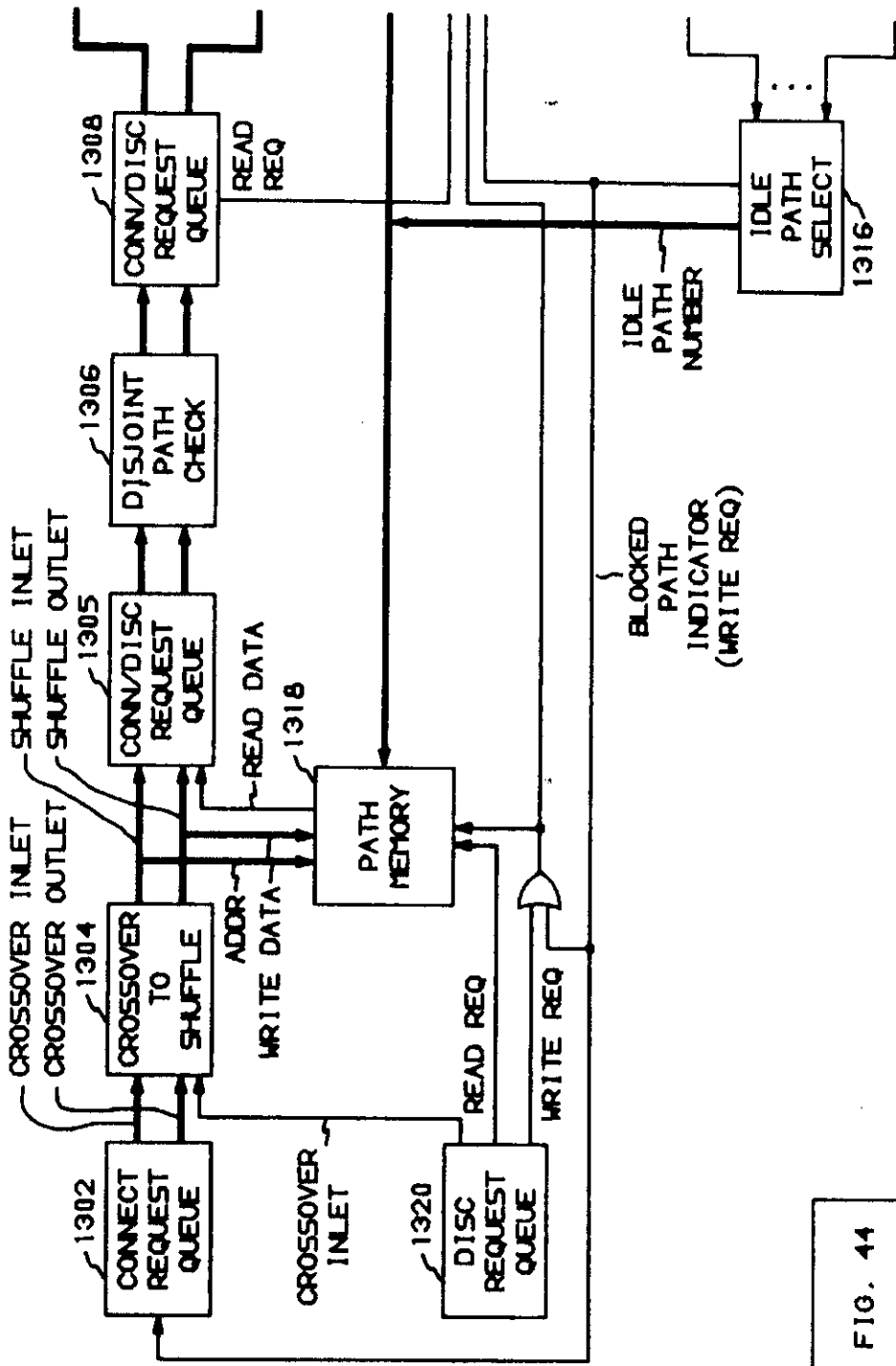

FIG. 40

CROSSOVER NETWORK  
DISCONNECT REQUEST





512 X 512  
CROSSOVER  
NETWORK  
CONTROLLER

FIG. 42	FIG. 43	FIG. 44
---------	---------	---------

FIG. 42

FIG. 41

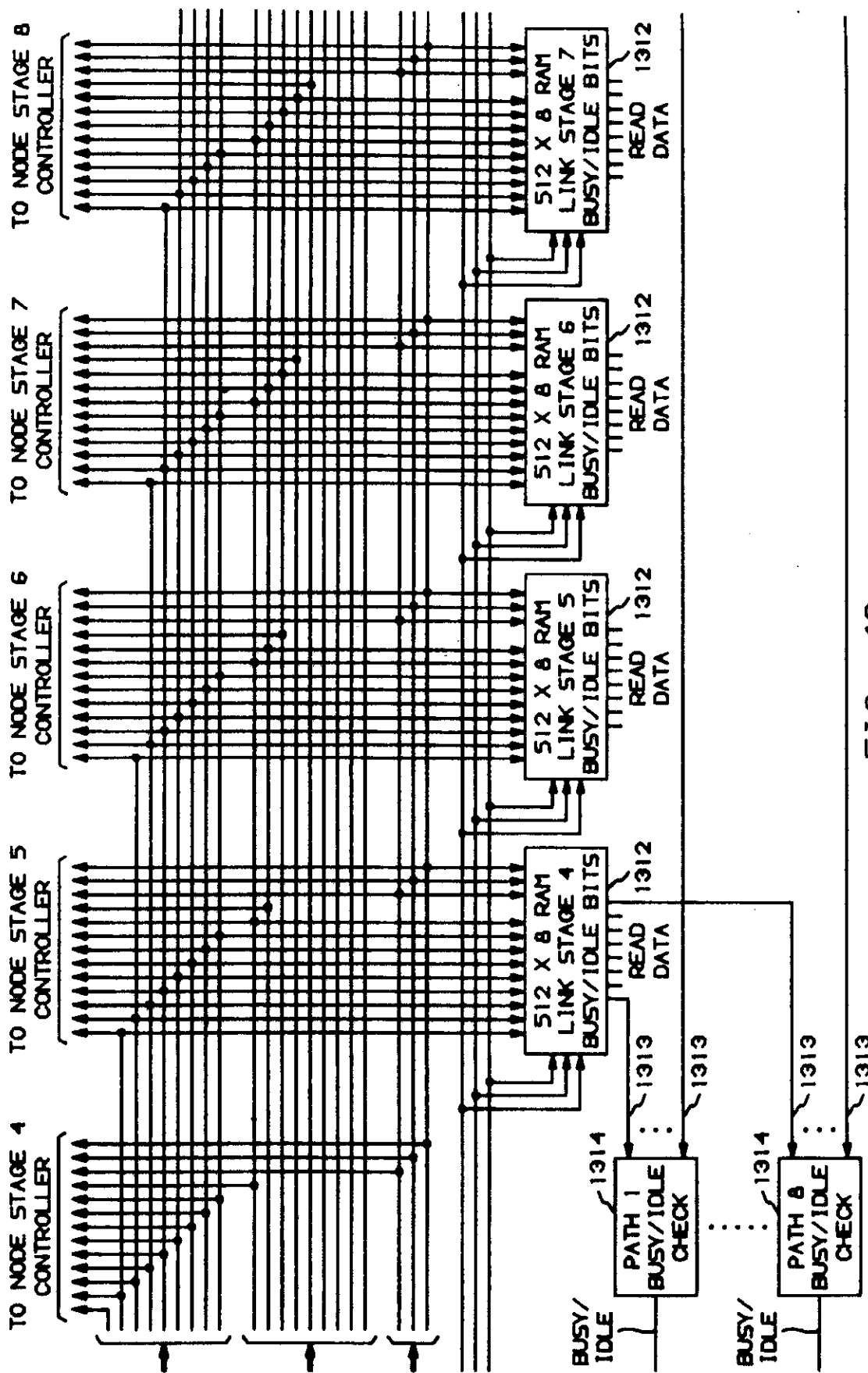

FIG. 43

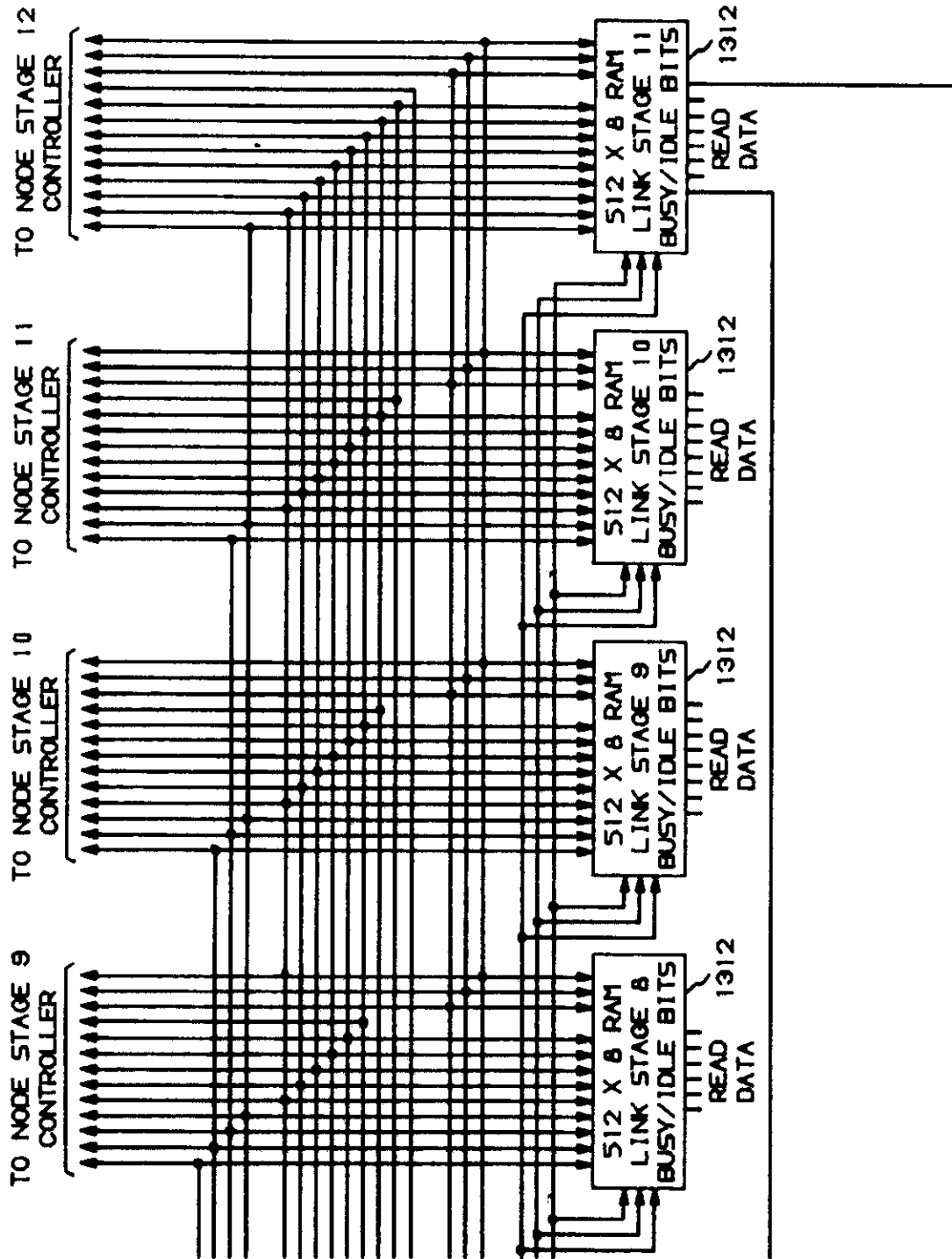

FIG. 44

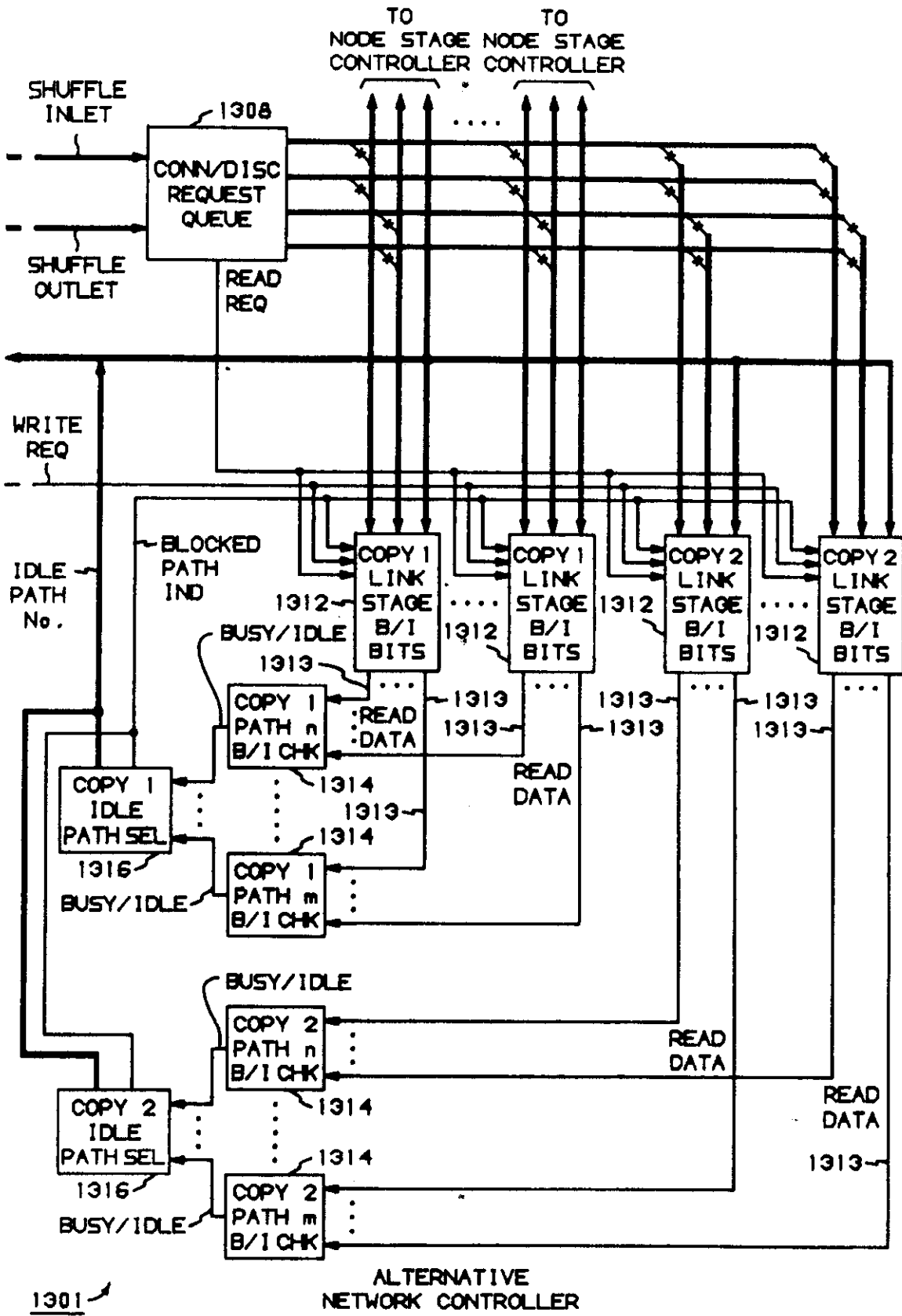

FIG. 45

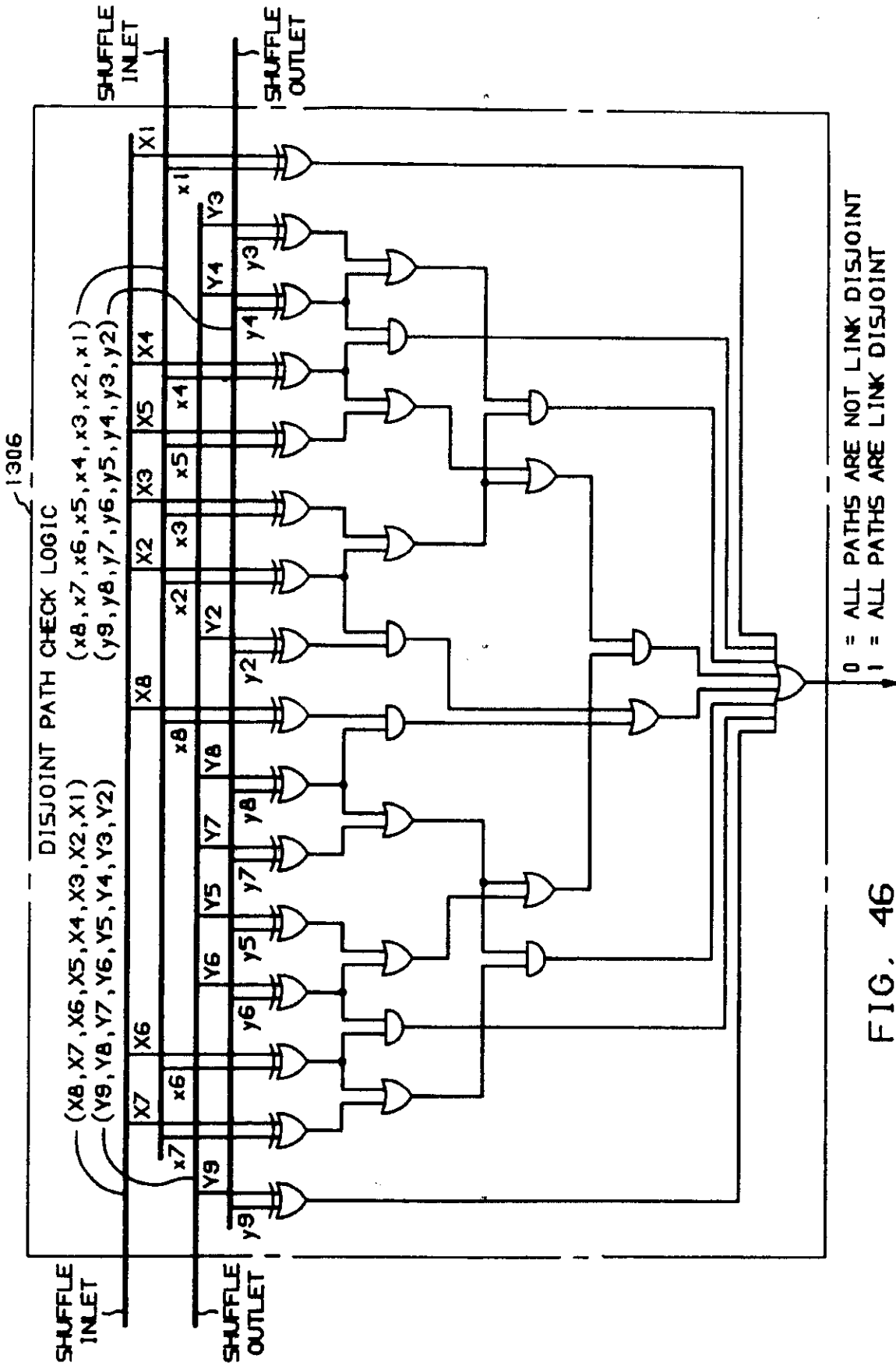

FIG. 46

$R_1$	$L_1$	$W_1$	
	$R_2$	$L_2$	$W_2$

FIG. 47

COPY 1	$R_1$	$L_1$	$W_1$		$W_3$	$W_4$
		$R_2$	$L_2$	$W_2$		
COPY 2	$R_3$	$L_3$	$W_1$		$W_2$	$W_3$
		$R_4$	$L_4$			$W_4$

FIG. 48

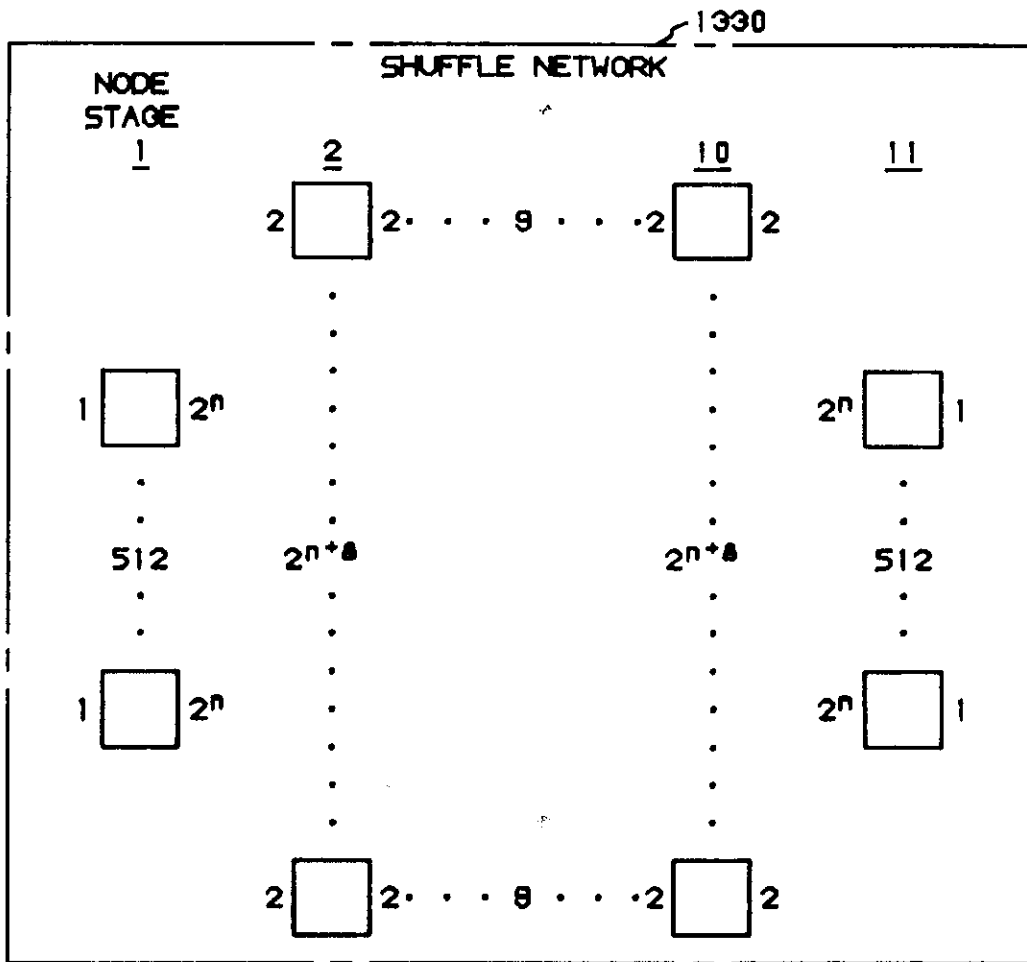

FIG. 49

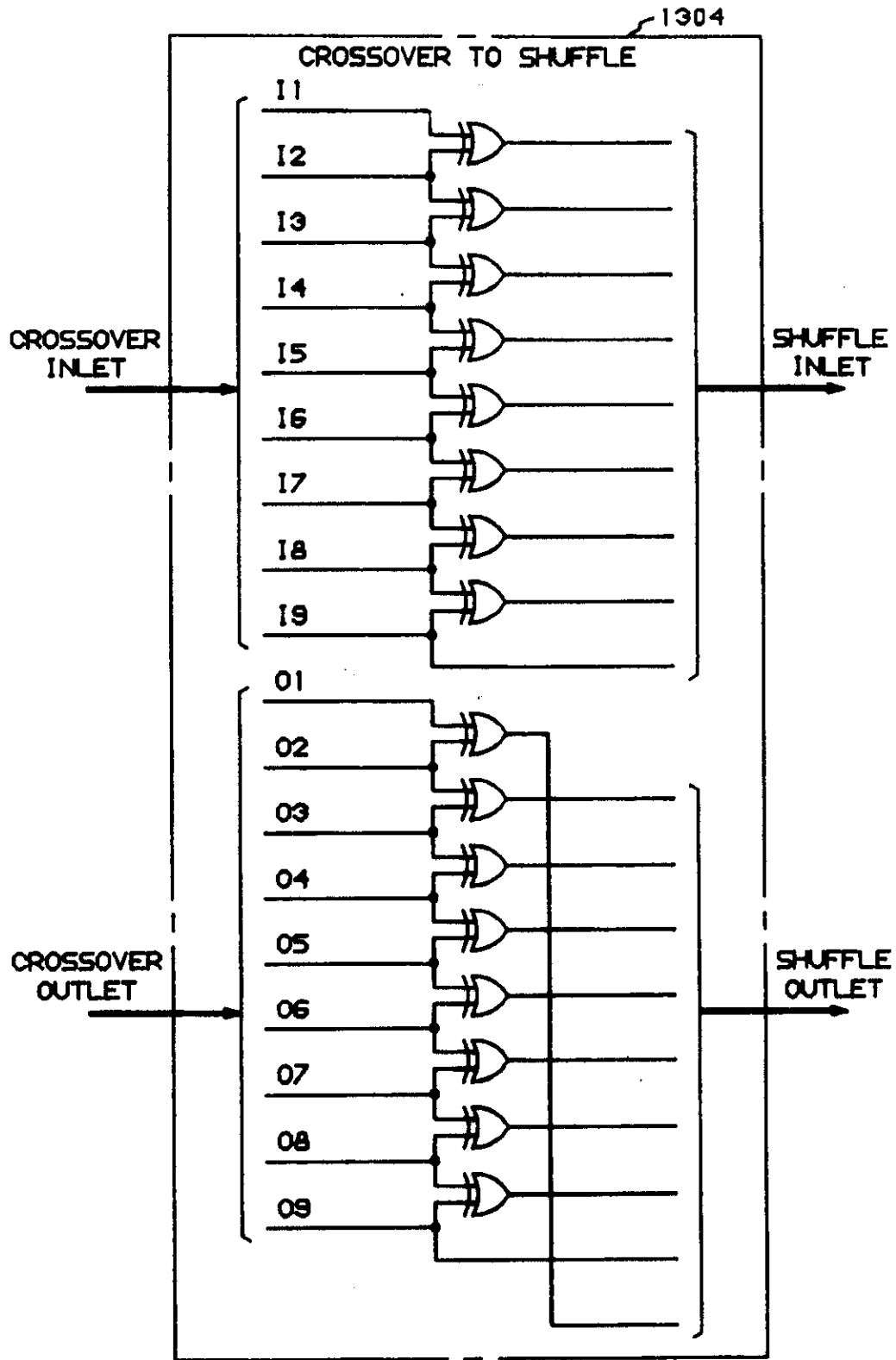

FIG. 50

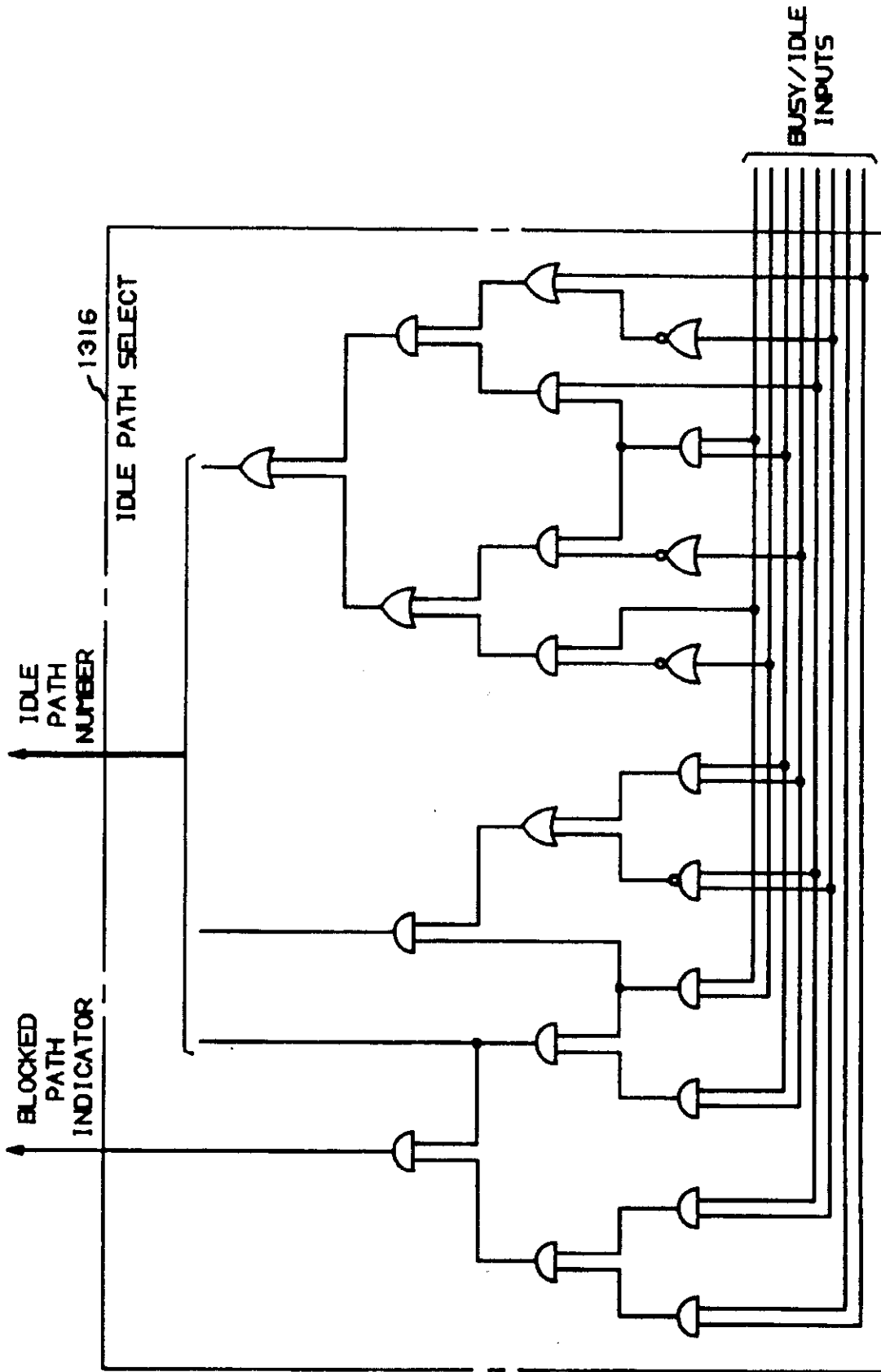
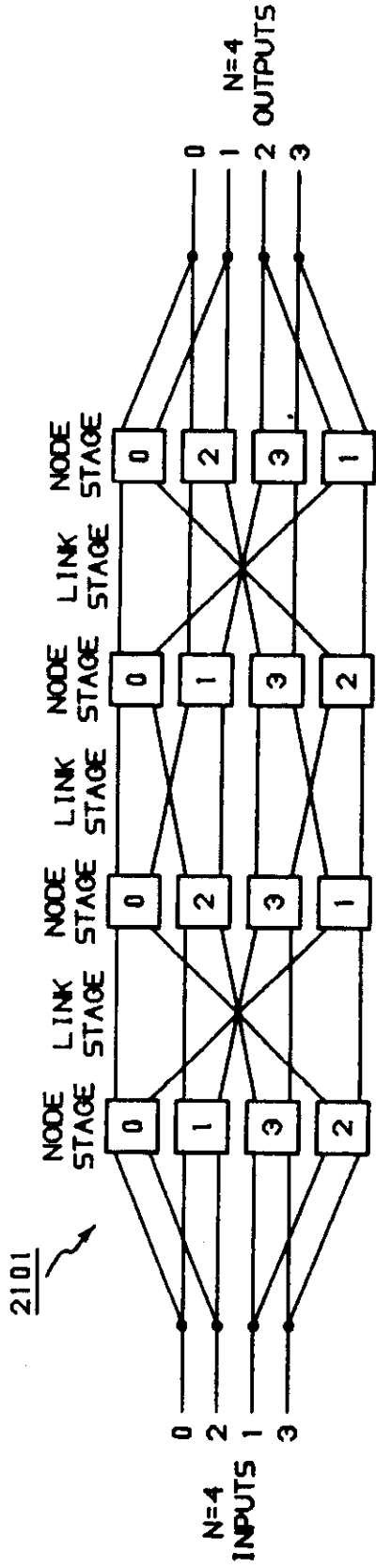
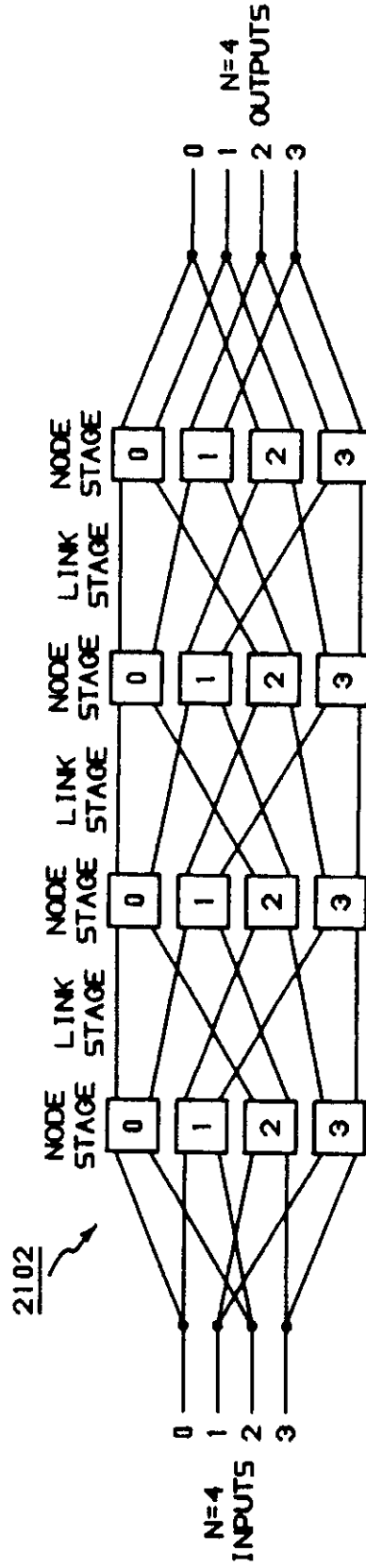

FIG. 51



CROSSOVER IMPLEMENTATION

FIG. 52



SHUFFLE IMPLEMENTATION

FIG. 53

FIG. 55

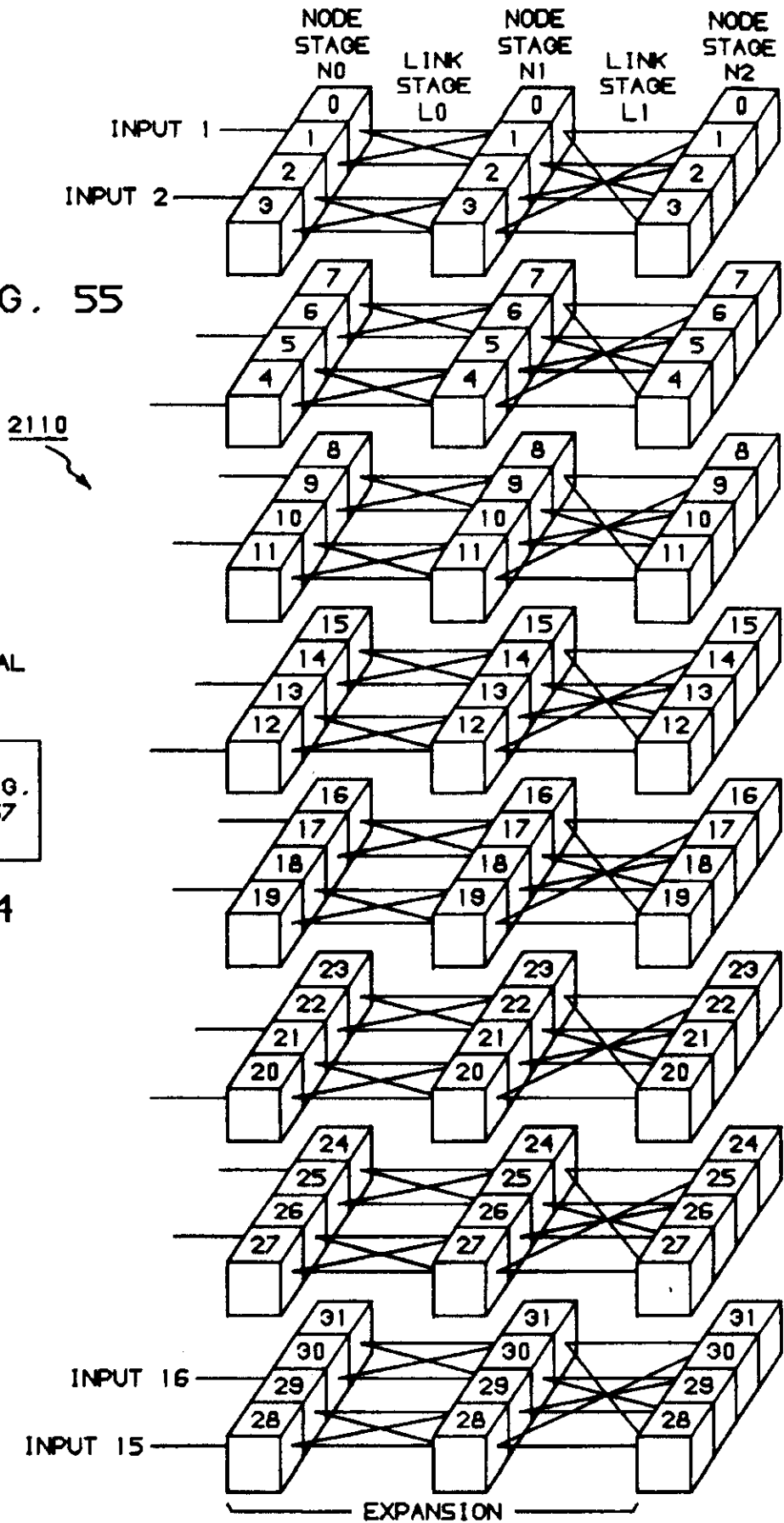

16 X 16  
3-DIMENSIONAL  
CROSSOVER  
NETWORK

FIG. 55	FIG. 56	FIG. 57
---------	---------	---------

FIG. 54

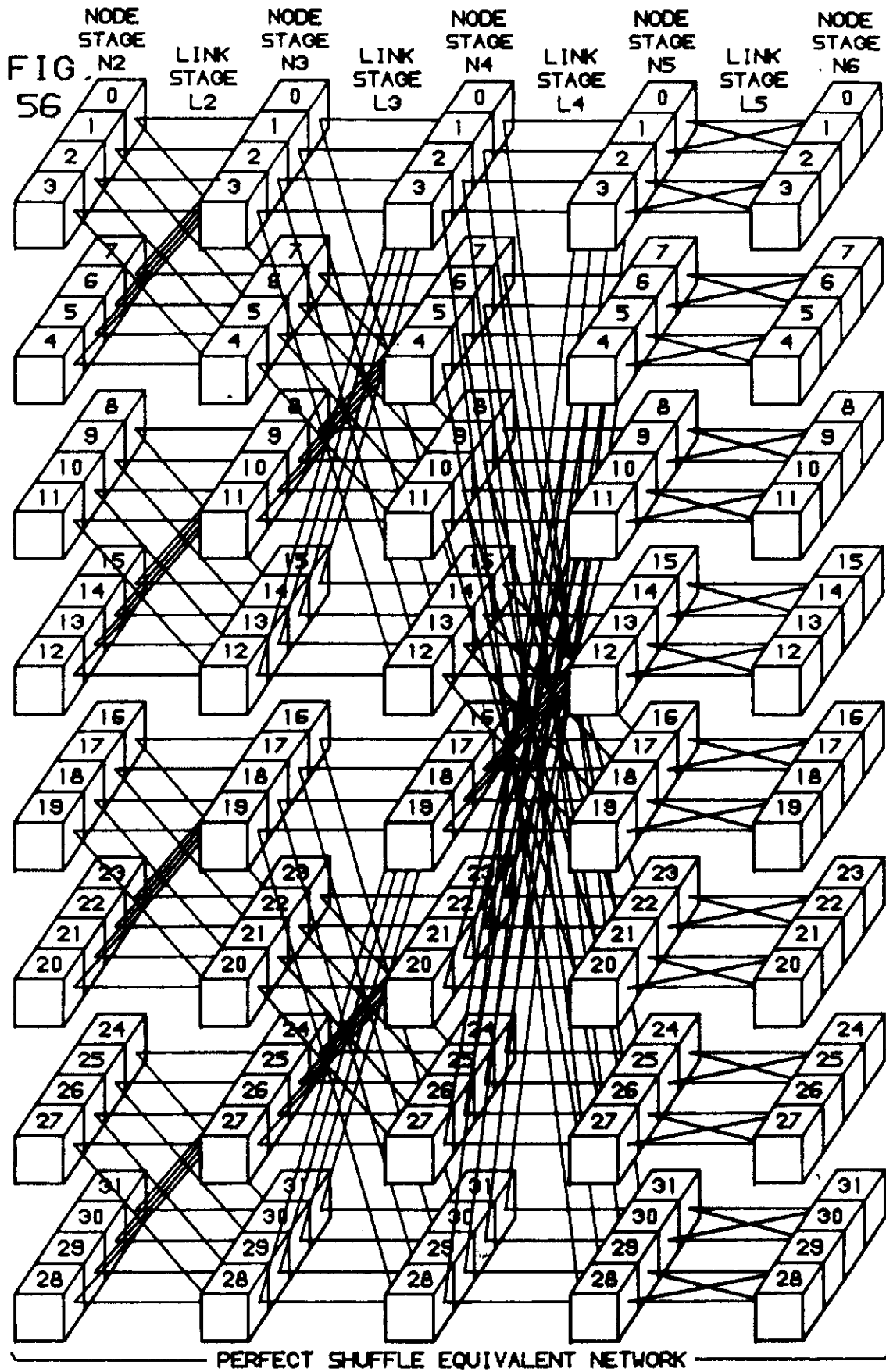

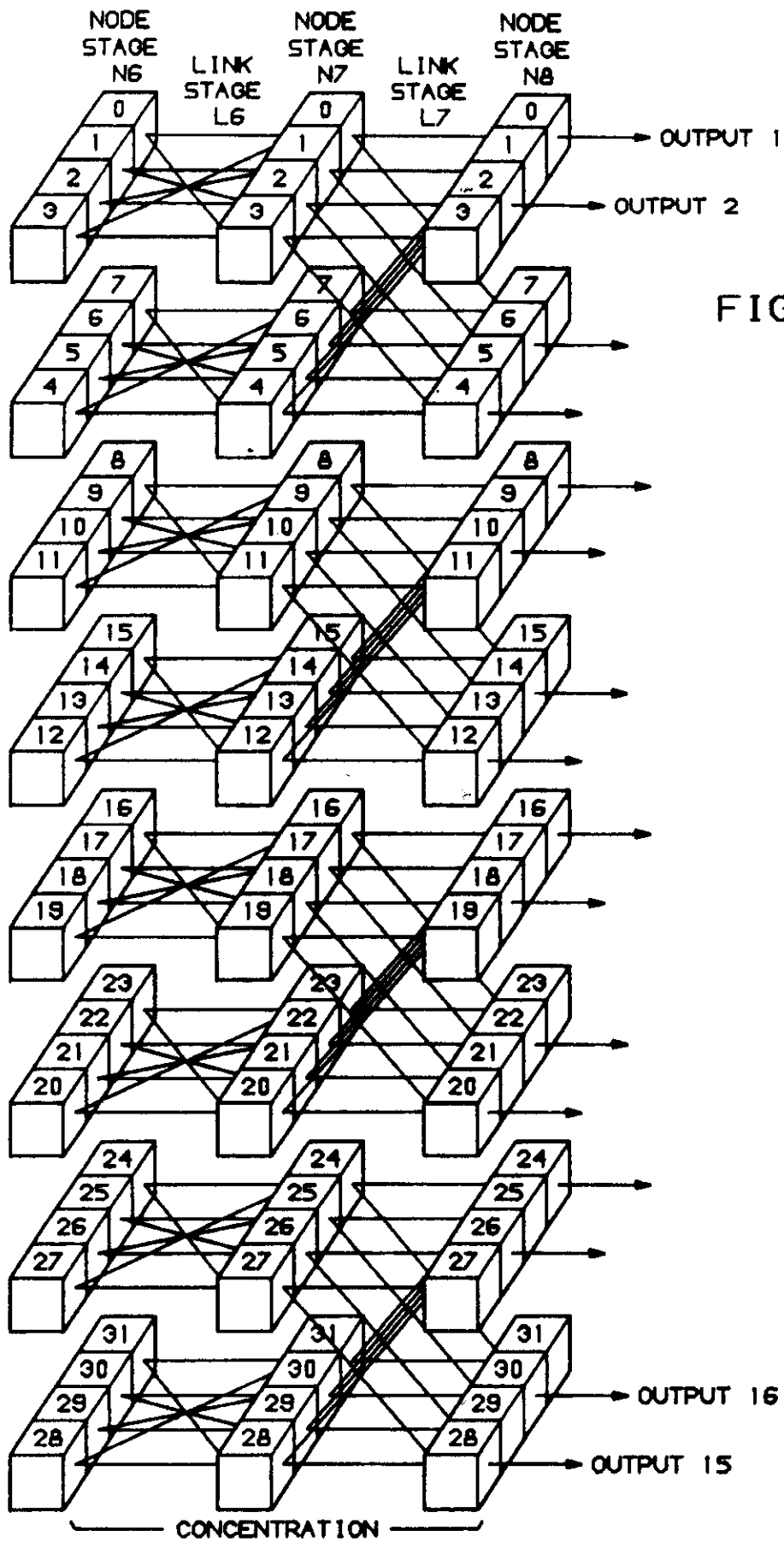
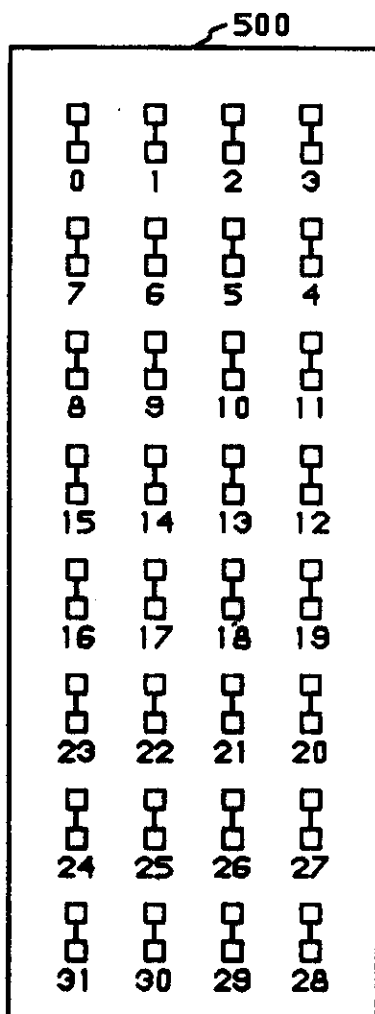

FIG. 57



S-SEED ARRAY

FIG. 58

2112

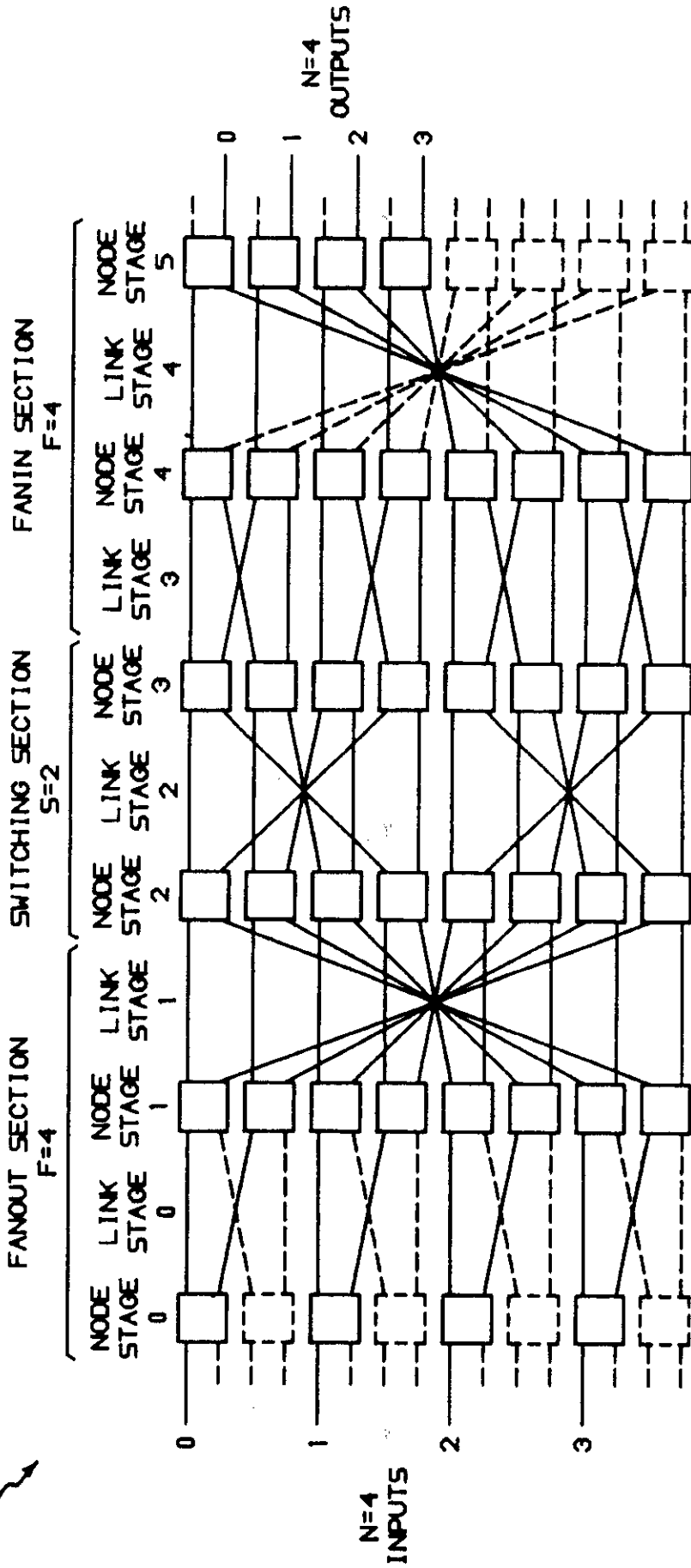

CROSSOVER IMPLEMENTATION

FIG. 59

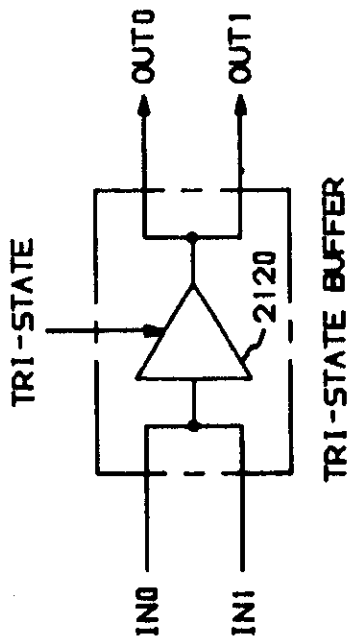
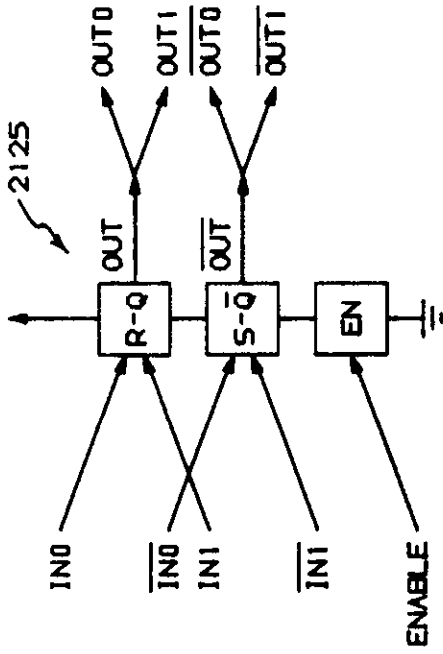

FIG. 60

TRI-STATE	IN0	IN1	OUT0	OUT1
0	HIGH IMPEDANCE	0	0	0
0	HIGH IMPEDANCE	1	1	1
0	0	HIGH IMPEDANCE	0	0
0	1	HIGH IMPEDANCE	1	1
1	DON'T CARE	DON'T CARE	HIGH IMPEDANCE	HIGH IMPEDANCE

TRUTH TABLE

FIG. 61



M-SEED IMPLEMENTATION

FIG. 63

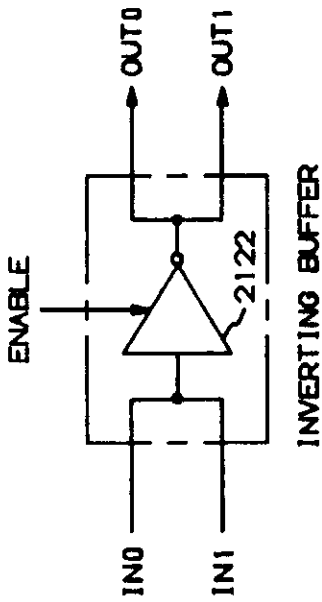

INVERTING BUFFER

FIG. 62

ENABLE	IN0	IN1	OUT0	OUT1
0	DON'T CARE	DON'T CARE	NO OPTICAL POWER	NO OPTICAL POWER
1	NO OPTICAL POWER	0	1	1
1	NO OPTICAL POWER	1	0	0
1	0	NO OPTICAL POWER	1	1
1	1	NO OPTICAL POWER	0	0

TRUTH TABLE

FIG. 64

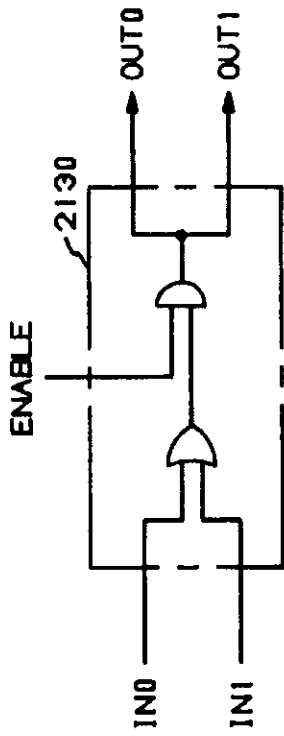

OR/AND LOGIC  
FIG. 65

ENABLE	IN0	IN1	OUT0	OUT1
0	0	0	0	0
0	0	1	0	0
0	1	0	0	0
0	1	1	0	0
1	0	0	0	0
1	0	1	1	1
1	1	0	1	1
1	1	1	1	1

TRUTH TABLE  
FIG. 66

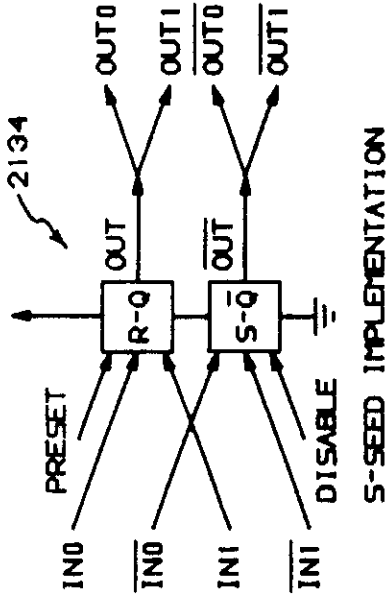

FIG. 68

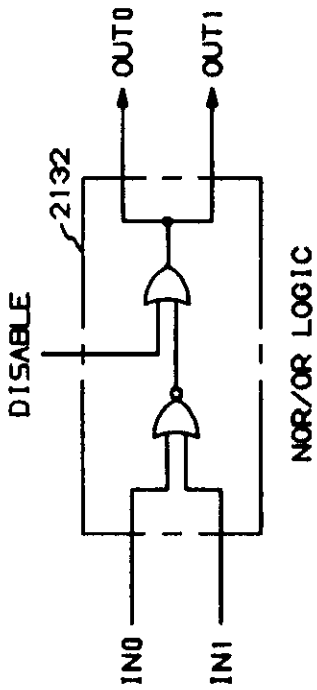

FIG. 67

DISABLE	IN0	IN1	$\overline{IN0}$	$\overline{IN1}$	P(S)	P(R)	OUT(t+1)	$\overline{OUT}(t+1)$
0	0	0	1	1	6.071	2.00	1	0
0	0	1	1	0	4.071	4.00	0	1
0	1	0	0	1	4.071	4.00	0	1
0	1	1	0	0	2.071	6.00	0	1
1	0	0	1	1	13.10	2.00	1	0
1	0	1	1	0	11.10	4.00	1	0
1	1	0	0	1	11.10	4.00	1	0
1	1	1	0	0	9.10	6.00	1	0

$$P(S) = P(\overline{IN0}) + P(\overline{IN1}) + P(DISABLE)$$

$$P(R) = P(IN0) + P(IN1)$$

TRUTH TABLE

FIG. 69

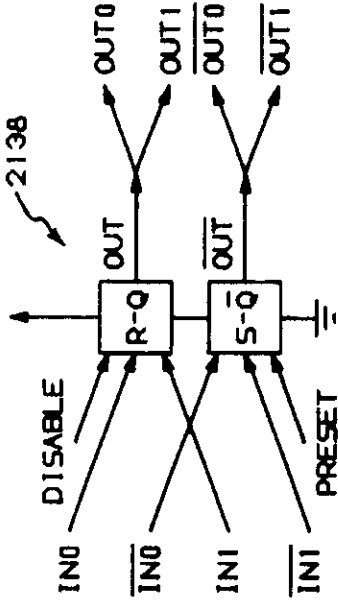

S-SEED IMPLEMENTATION

FIG. 71

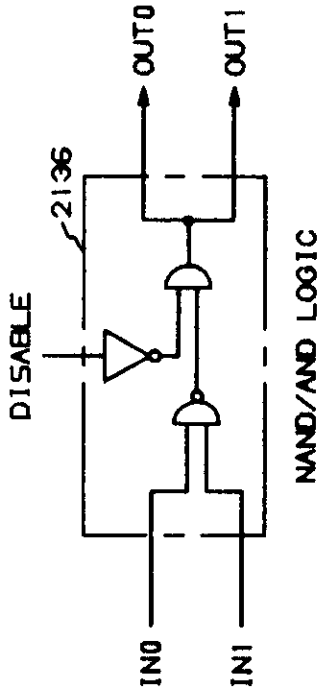

NAND/AND LOGIC

FIG. 70

DISABLE	IN0	IN1	$\overline{IN0}$	$\overline{IN1}$	P(R)	P(S)	OUT(t+1)	$\overline{OUT}(t+1)$
0	0	0	1	1	2.071	6.00	1	0
0	0	1	1	0	4.071	4.00	1	0
0	1	0	0	1	4.071	4.00	1	0
0	1	1	0	0	6.071	2.00	0	1
1	0	0	1	1	9.10	6.00	0	1
1	0	1	1	0	11.10	4.00	0	1
1	1	0	0	1	11.10	4.00	0	1
1	1	1	0	0	13.10	2.00	0	1

$$P(R) = P(IN0) + P(IN1) + P(DISABLE)$$

$$P(S) = P(\overline{IN0}) + P(\overline{IN1})$$

TRUTH TABLE

FIG. 72

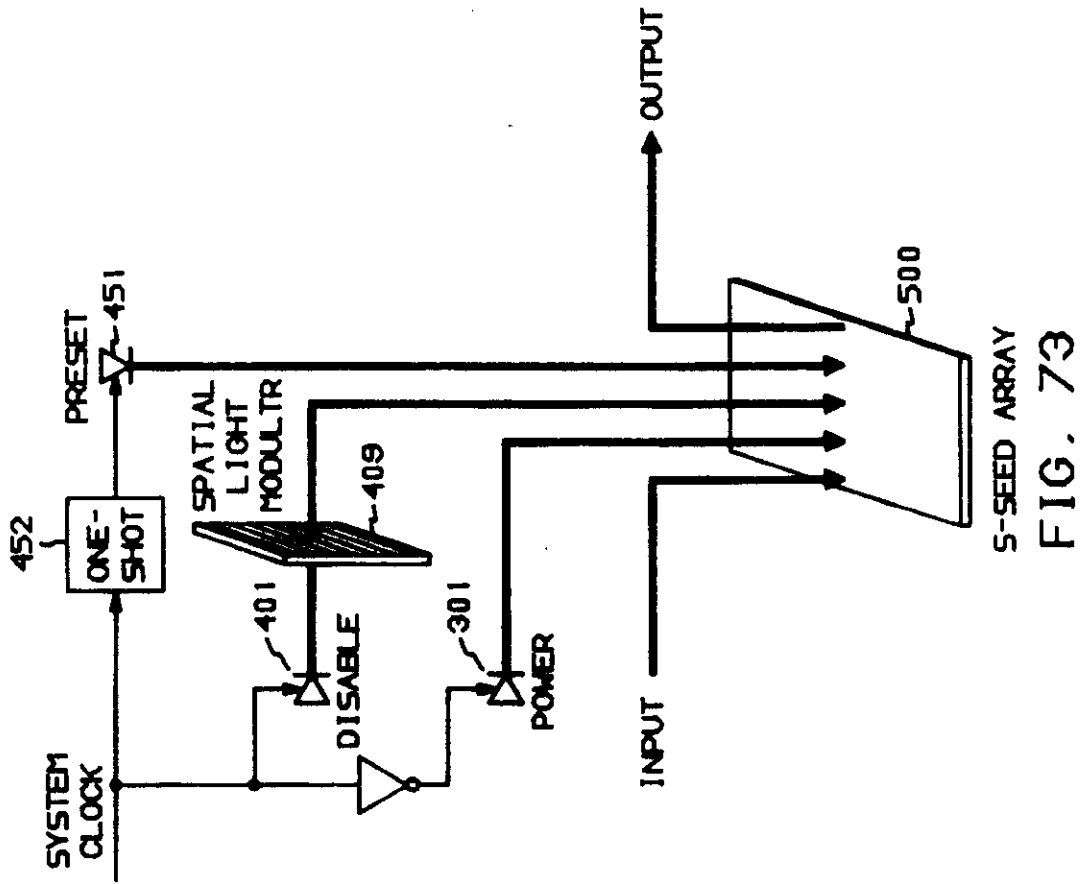

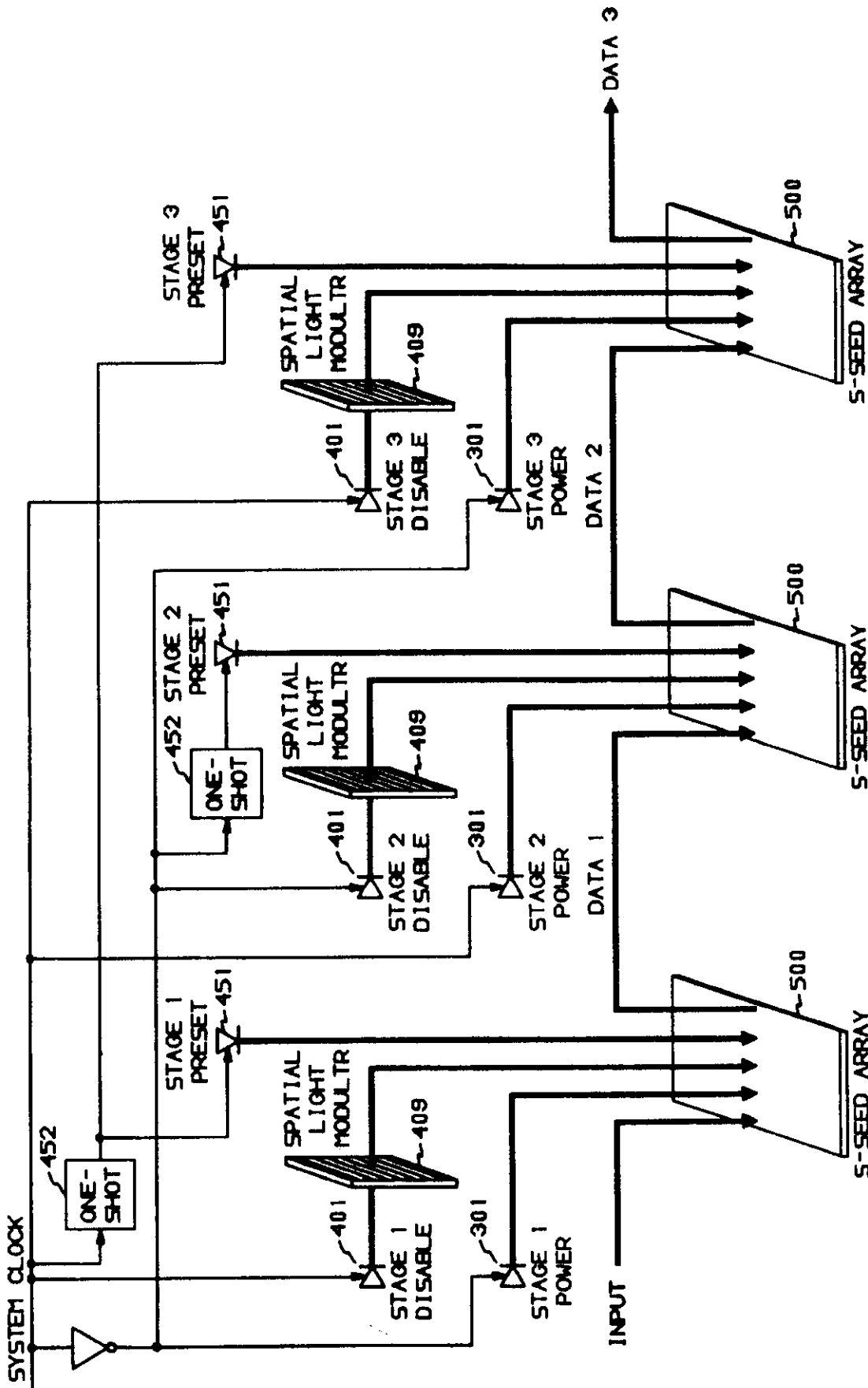

FIG. 74

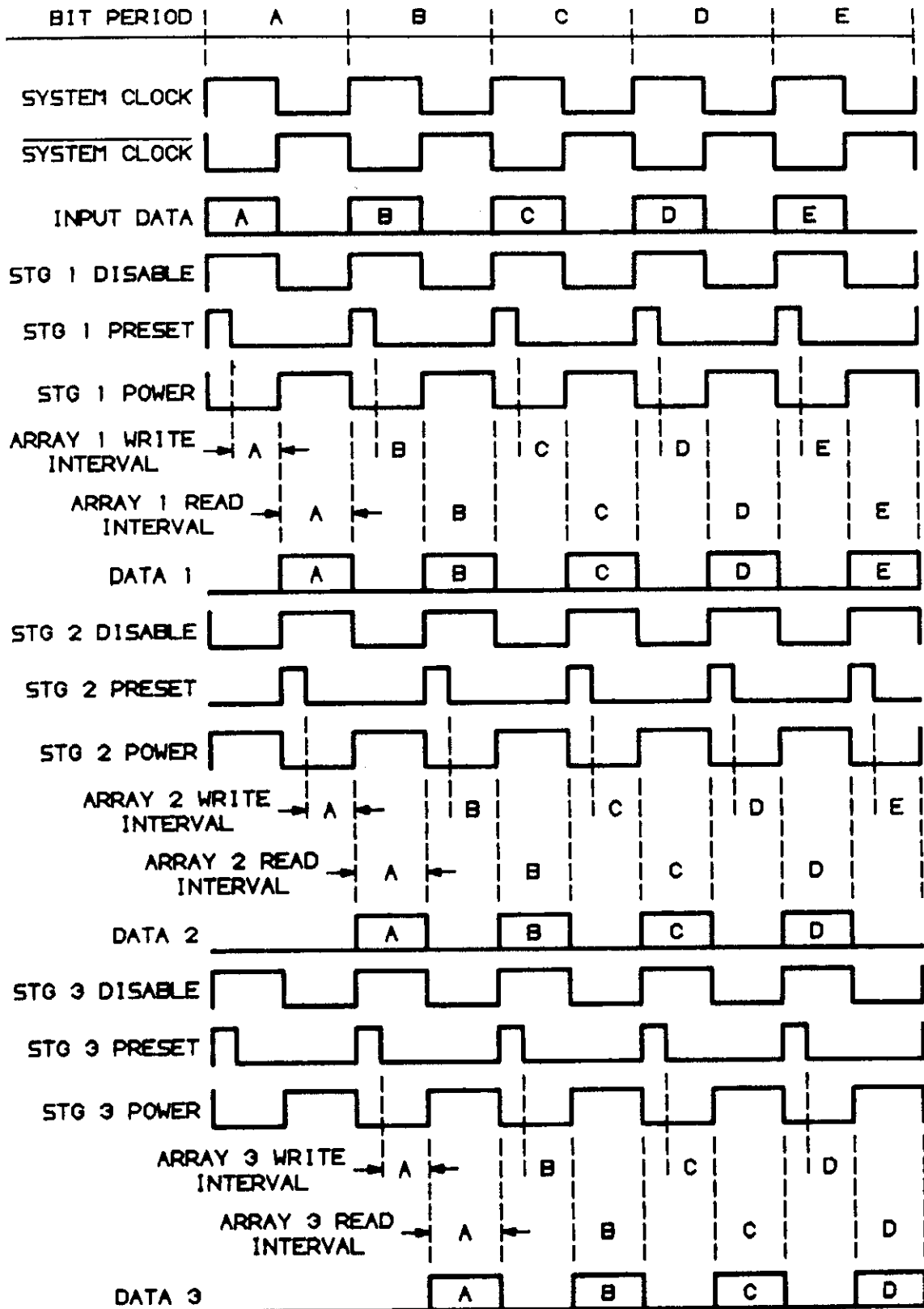
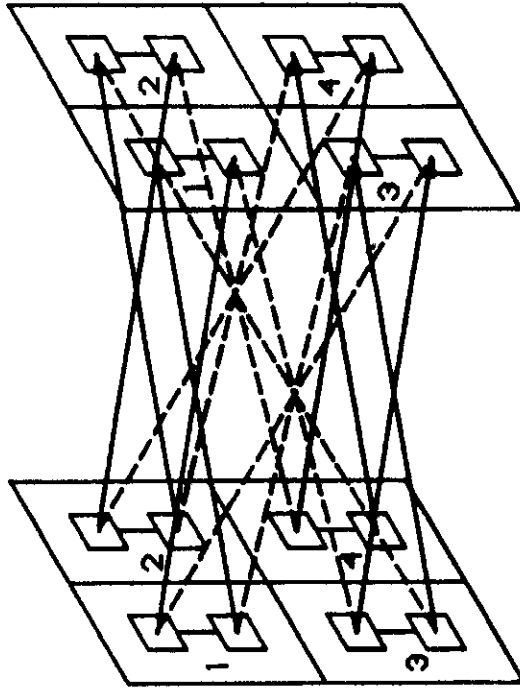
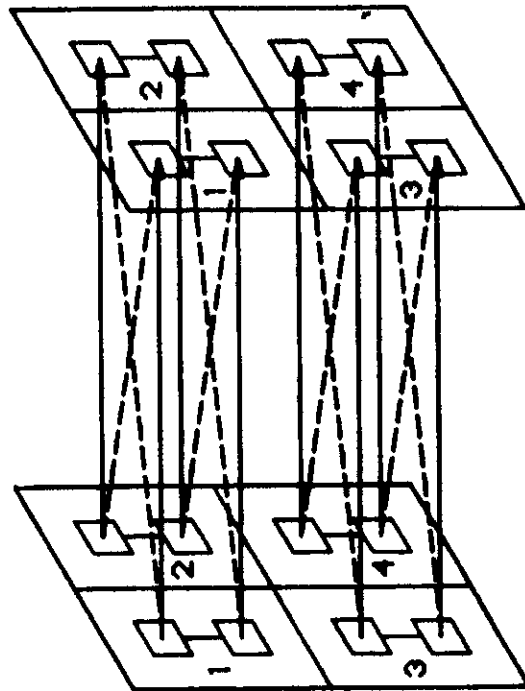

FIG. 75



VERTICAL CONNECTIONS

FIG. 77



HORIZONTAL CONNECTIONS

FIG. 76

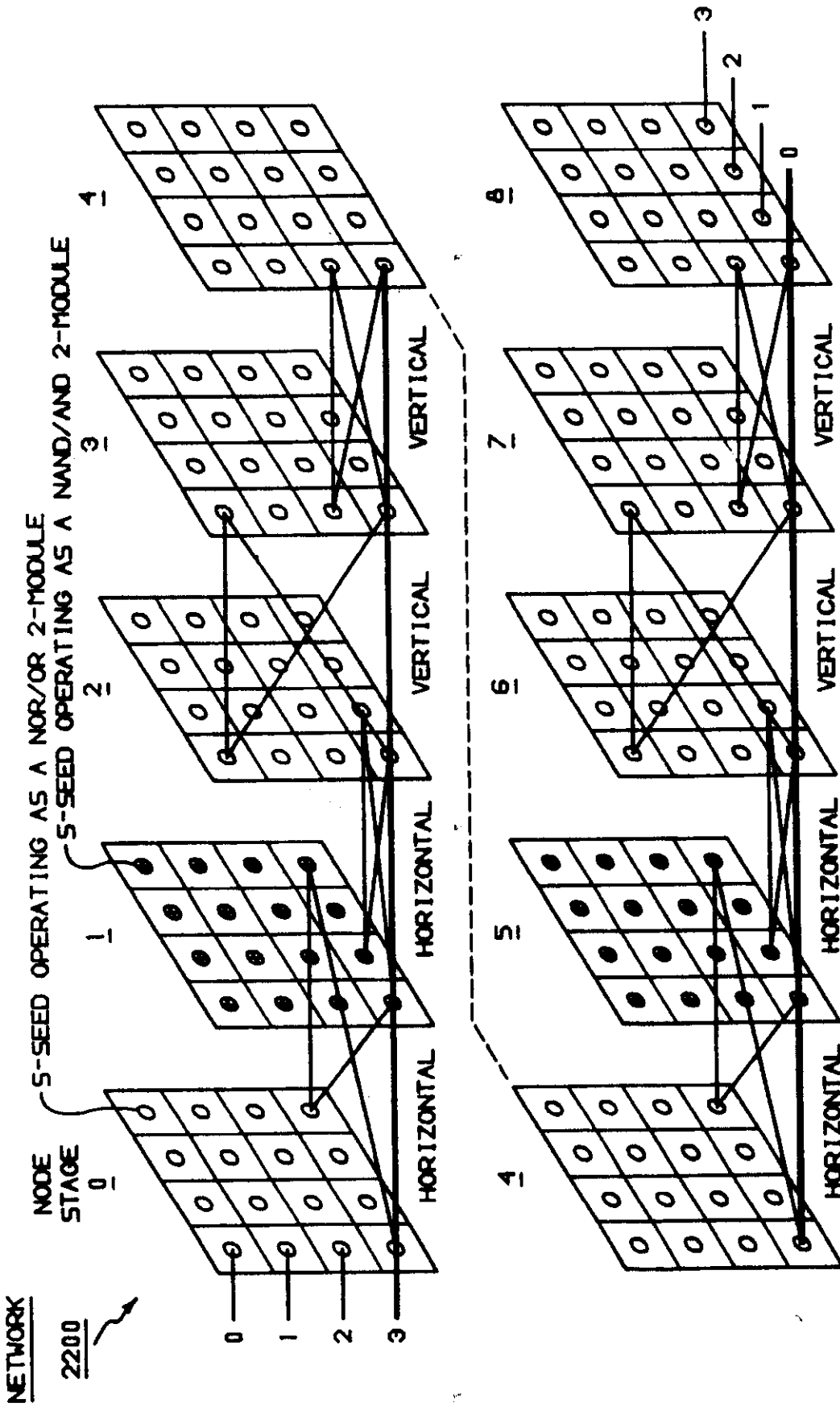

FIG. 78

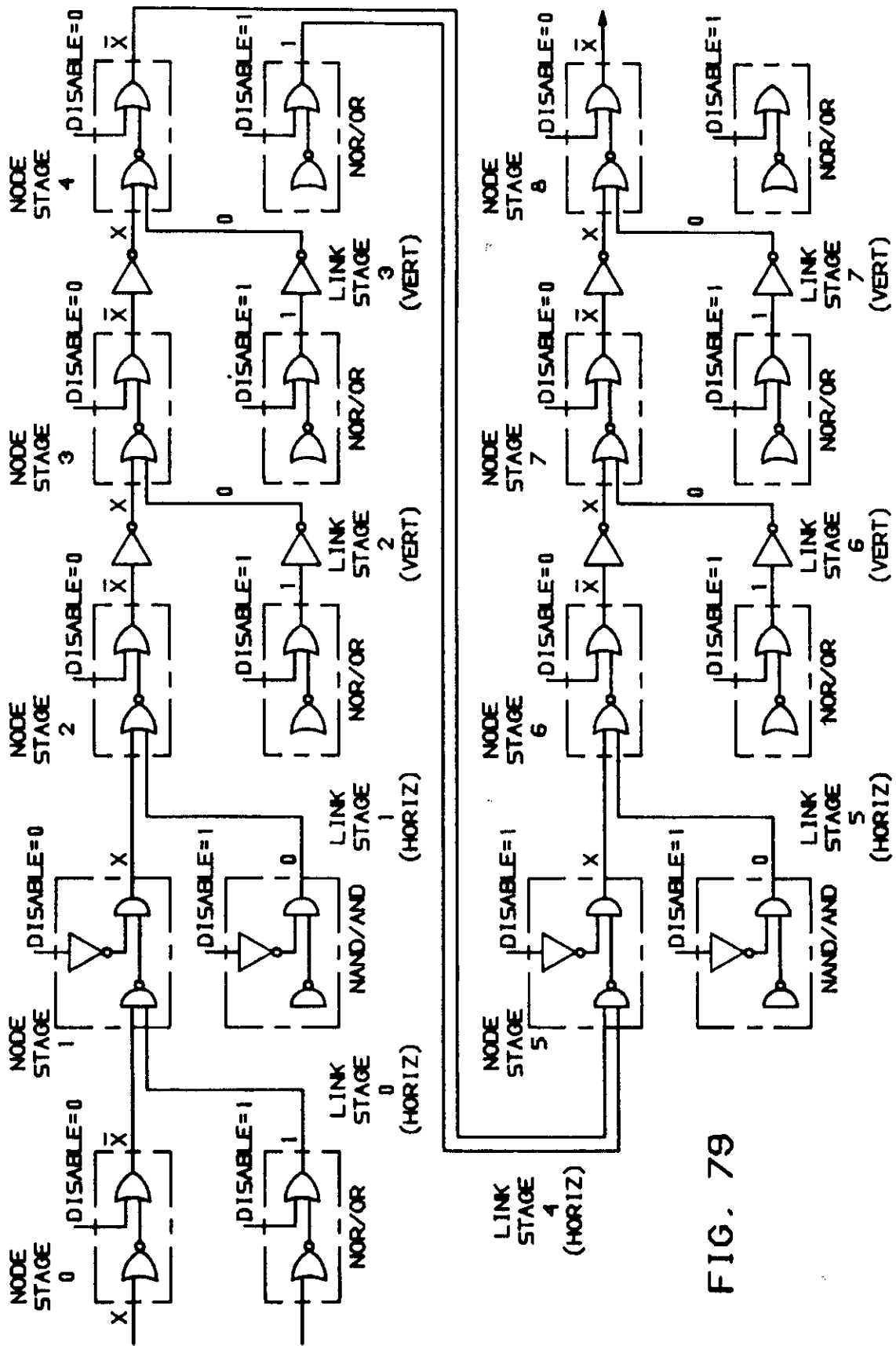

FIG. 79

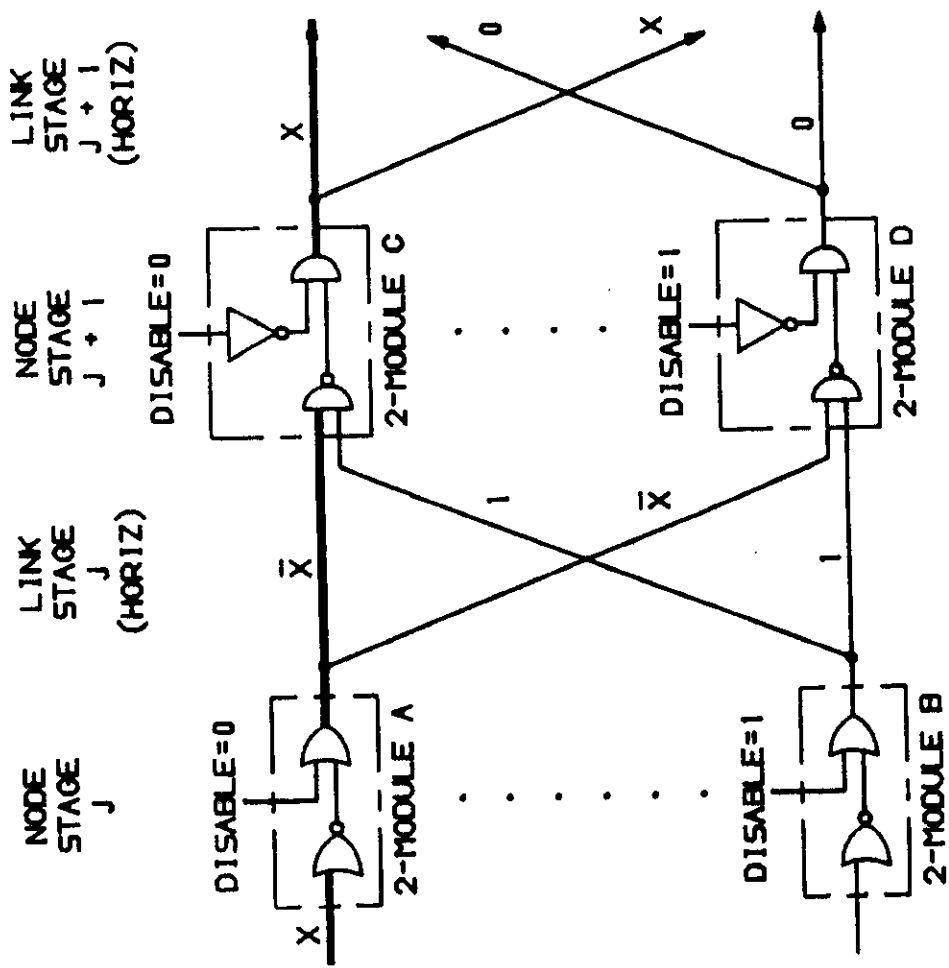

FIG. 80

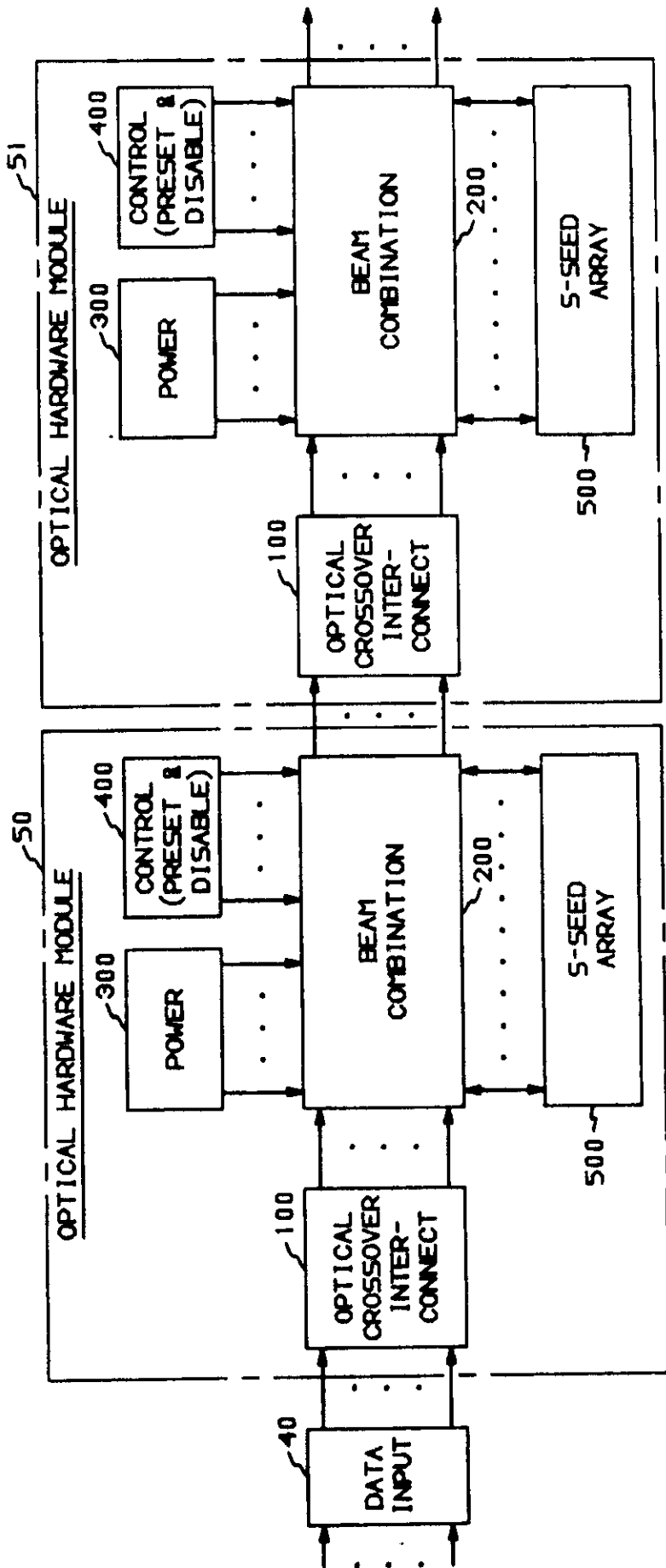

FIG. 81

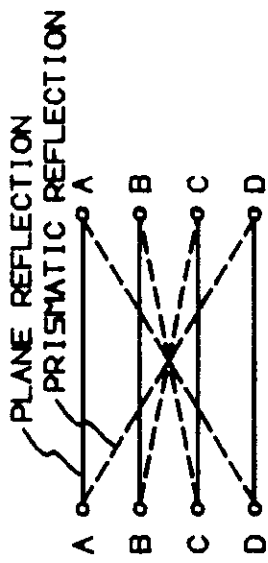

FIG. 83

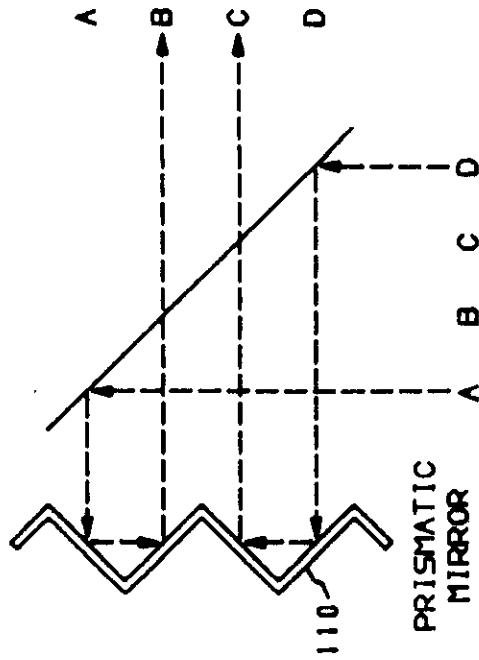

FIG. 84

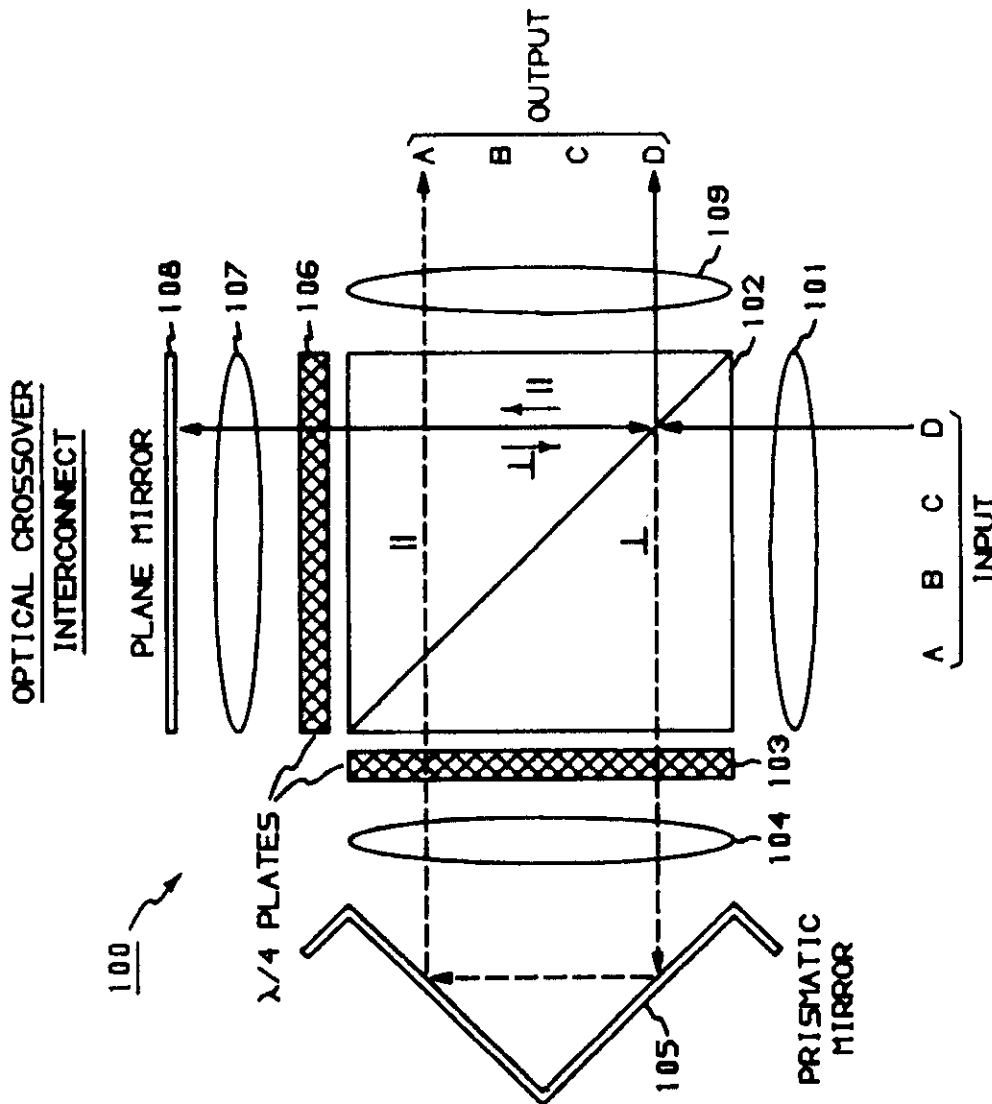

FIG. 82

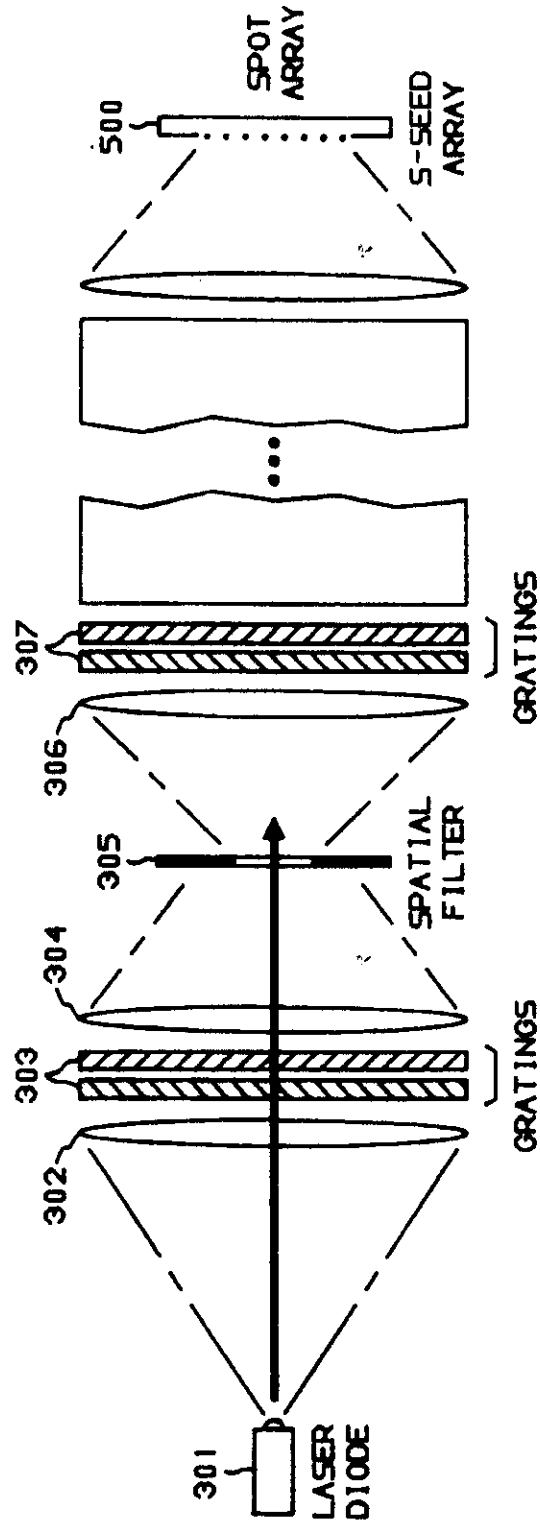

FIG. 85

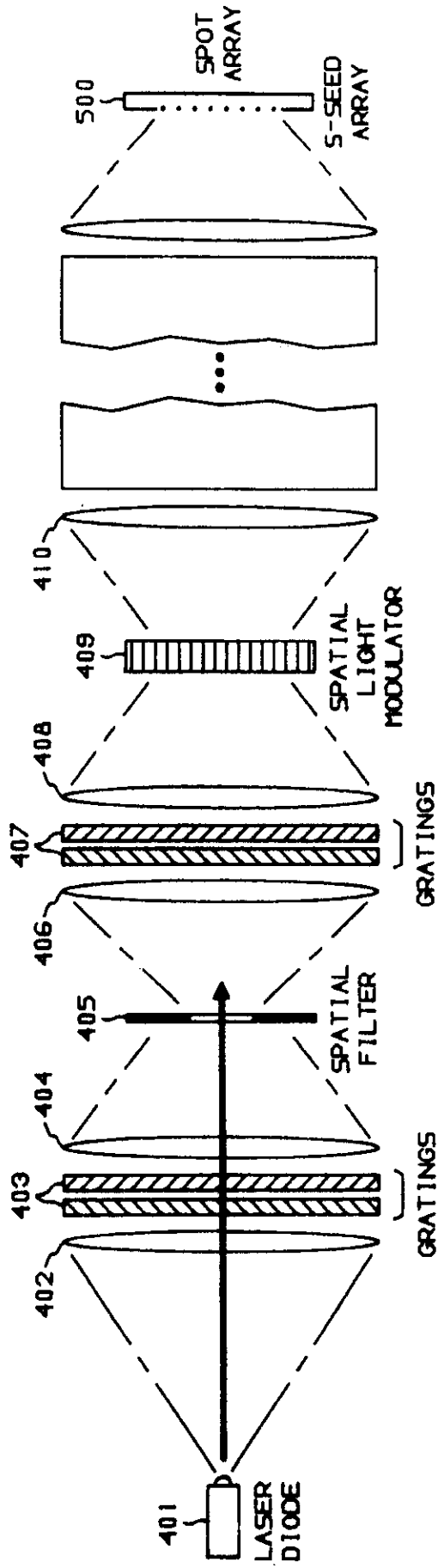
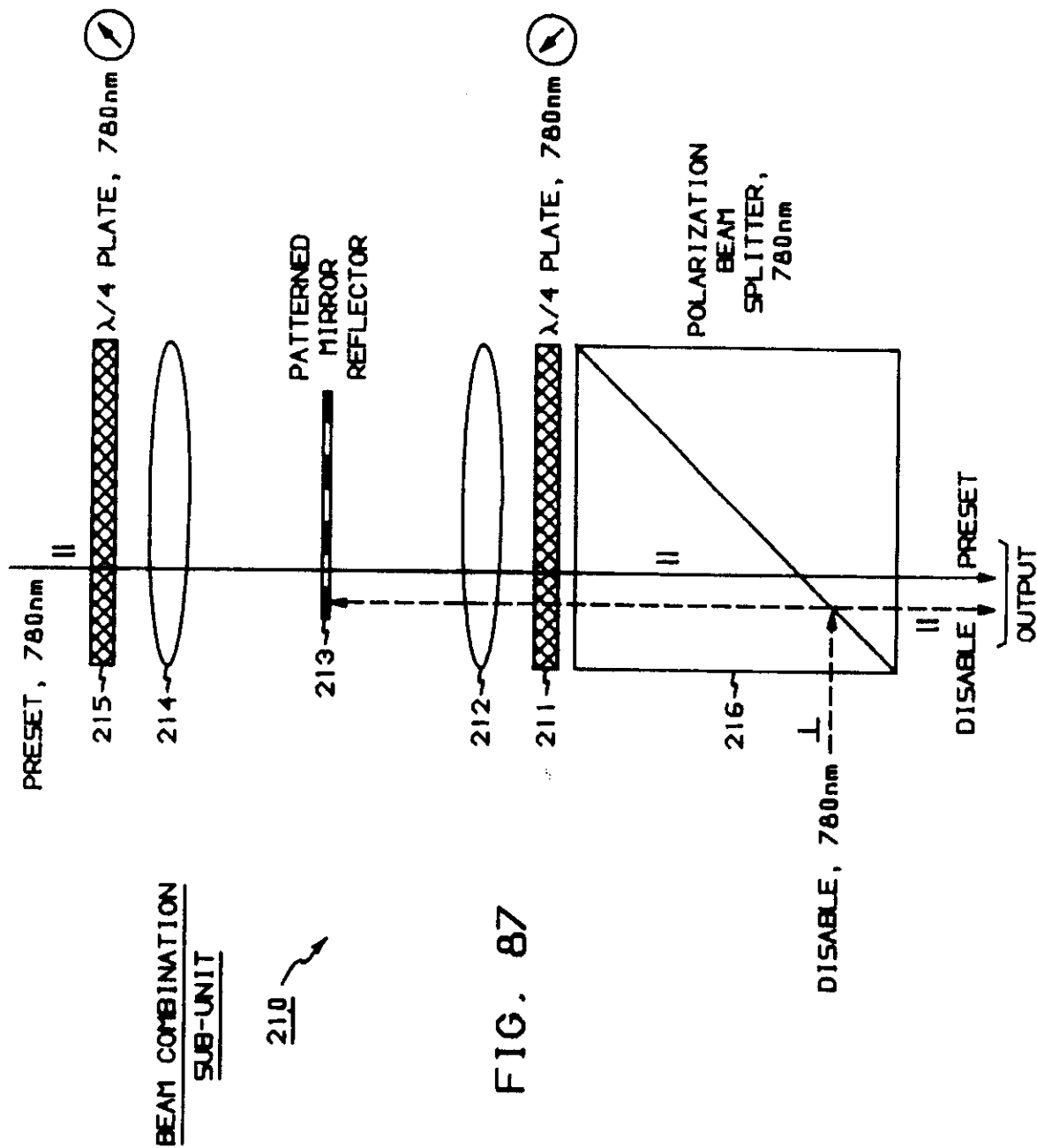

FIG. 86



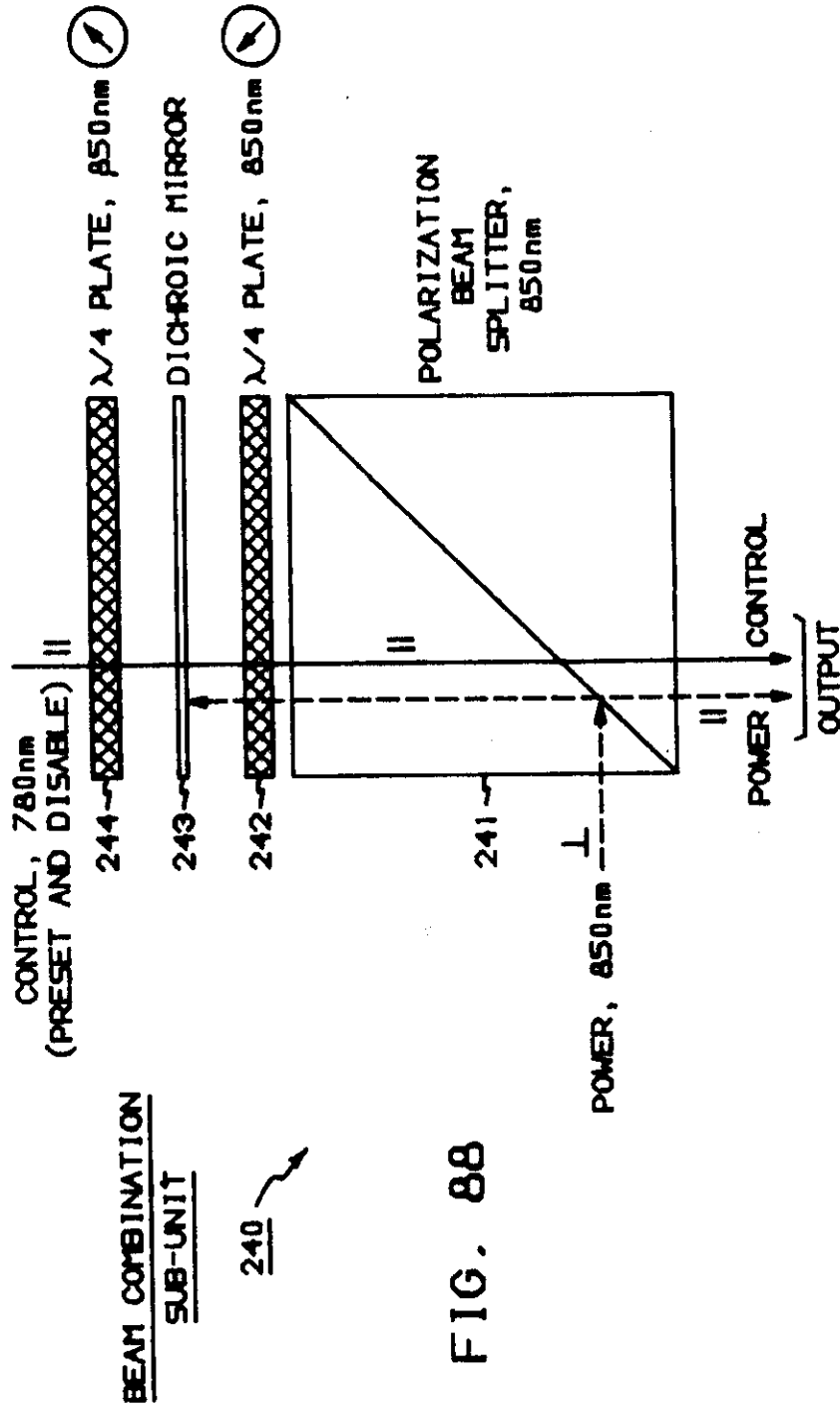

FIG. 88

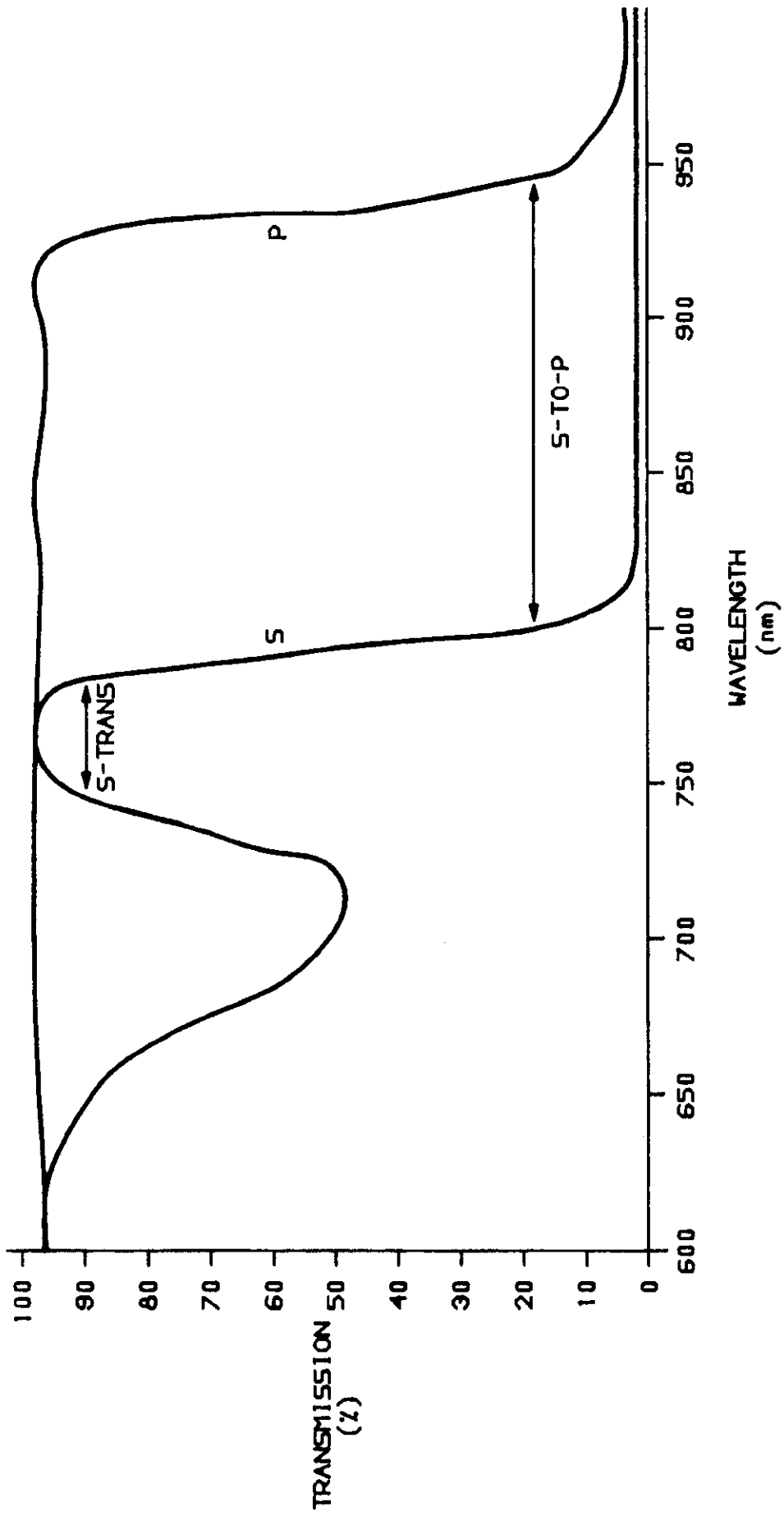
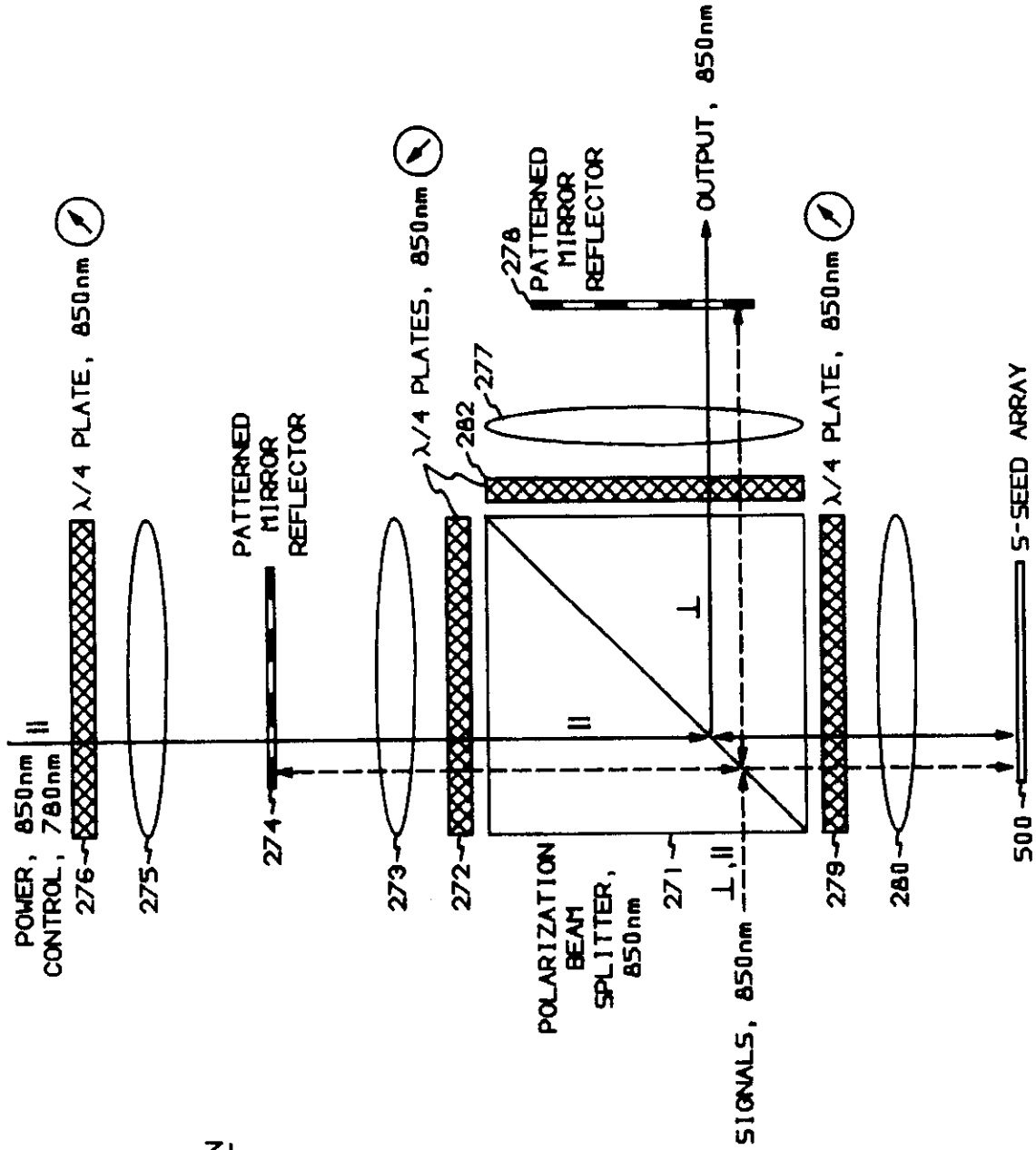

FIG. 89



BEAM COMBINATION  
SUB-UNIT

270

FIG. 90

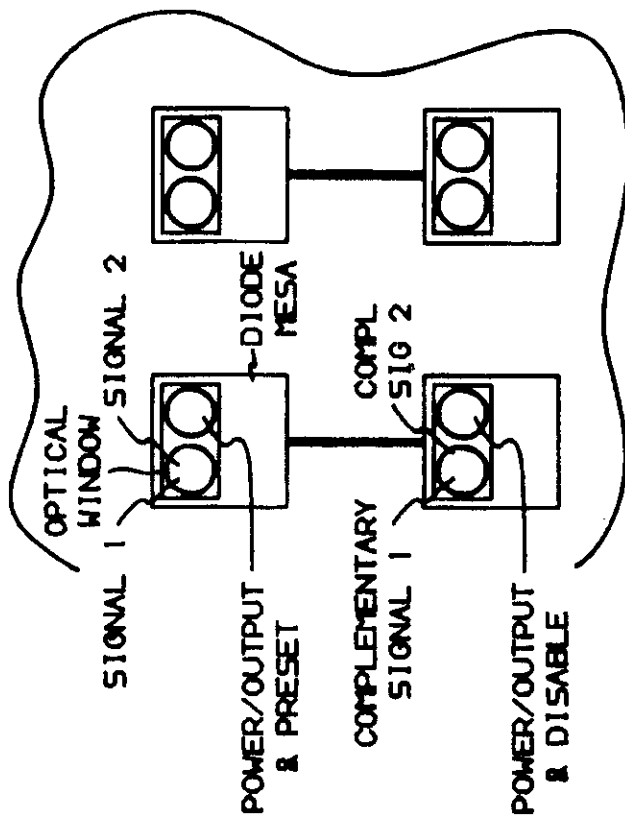

S-SEED ARRAY

FIG. 92

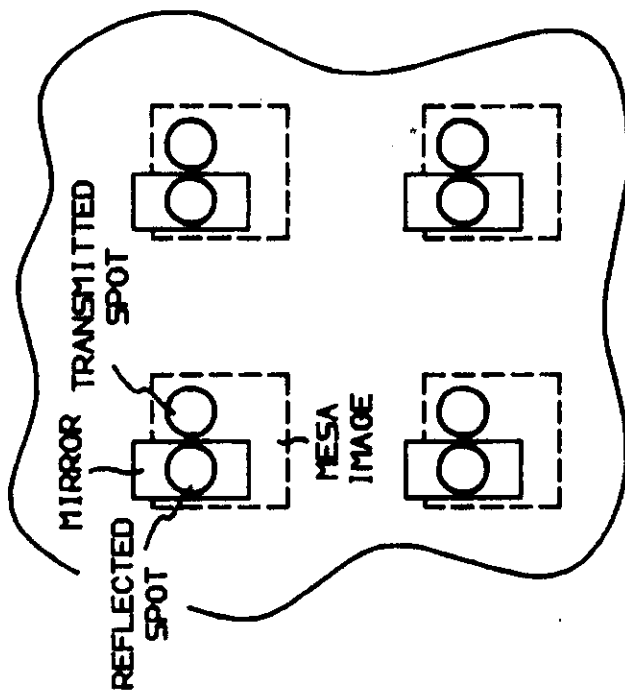

PATTERNED MIRROR REFLECTOR

FIG. 91

FIG. 93

OPTICAL HARDWARE MODULE

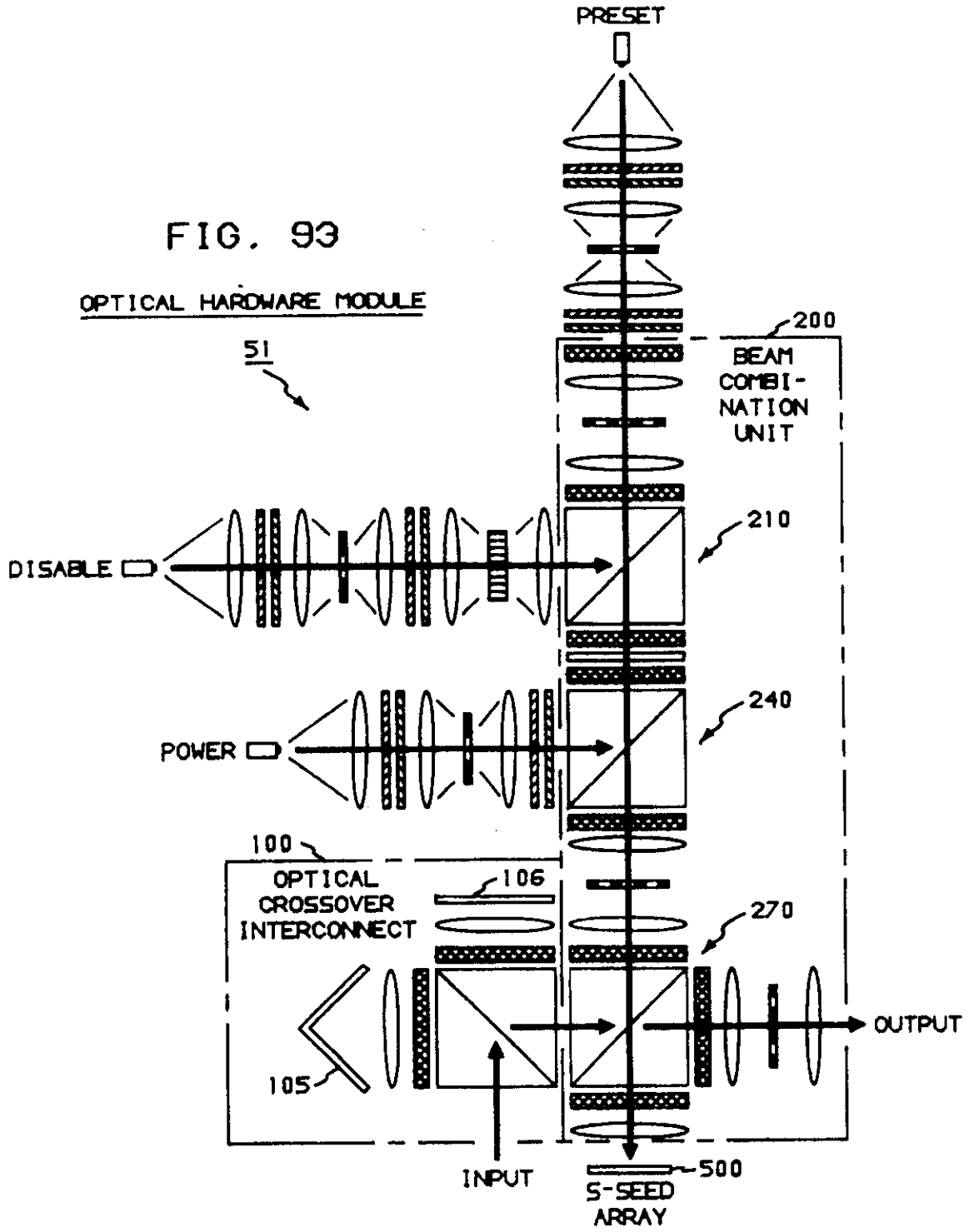

FIG. 94  
 CASCADED  
 OPTICAL HARDWARE MODULES  
 FOR 2 NODE STAGES

FIG. 95	FIG. 96
------------	------------

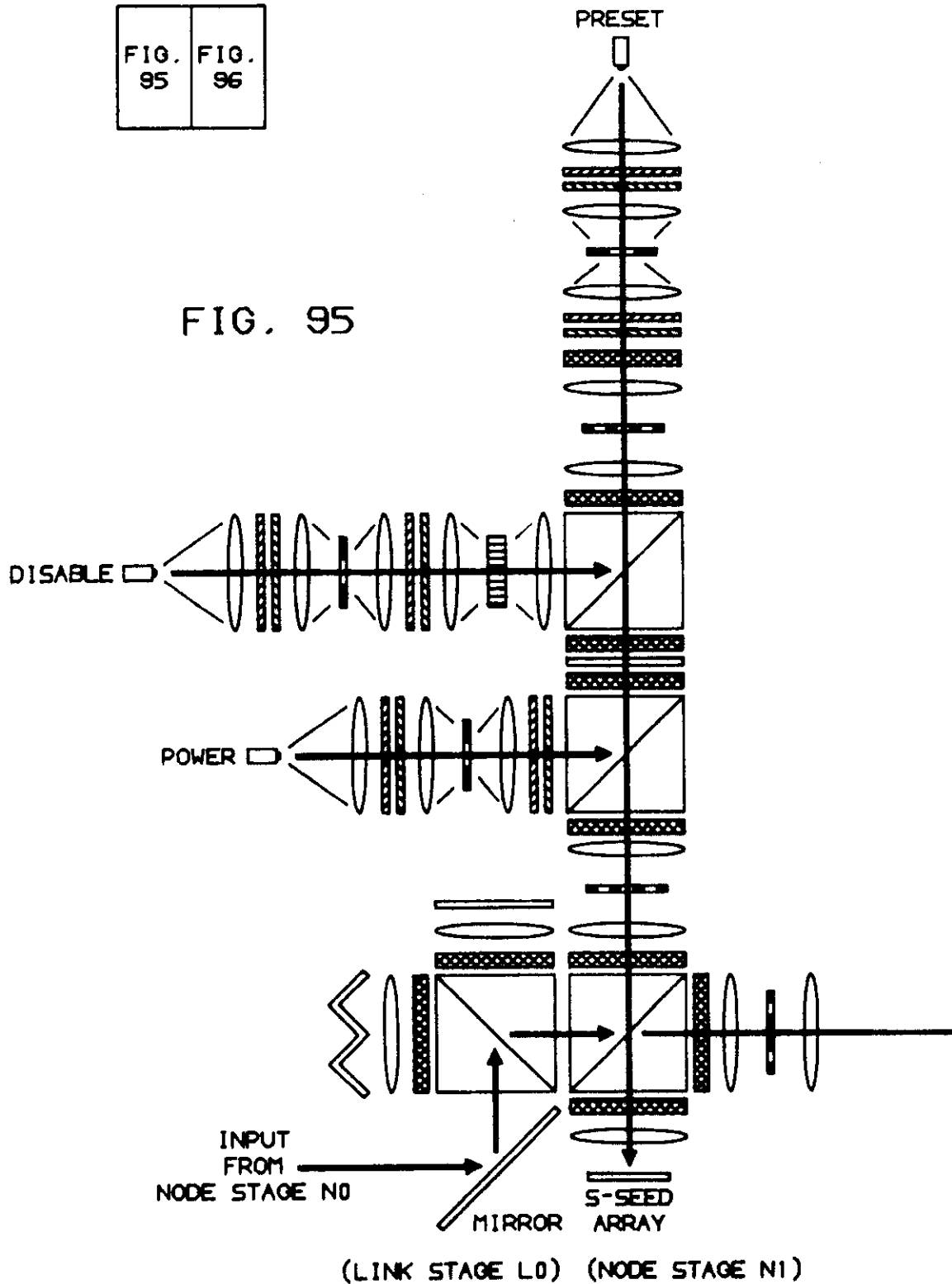

FIG. 96

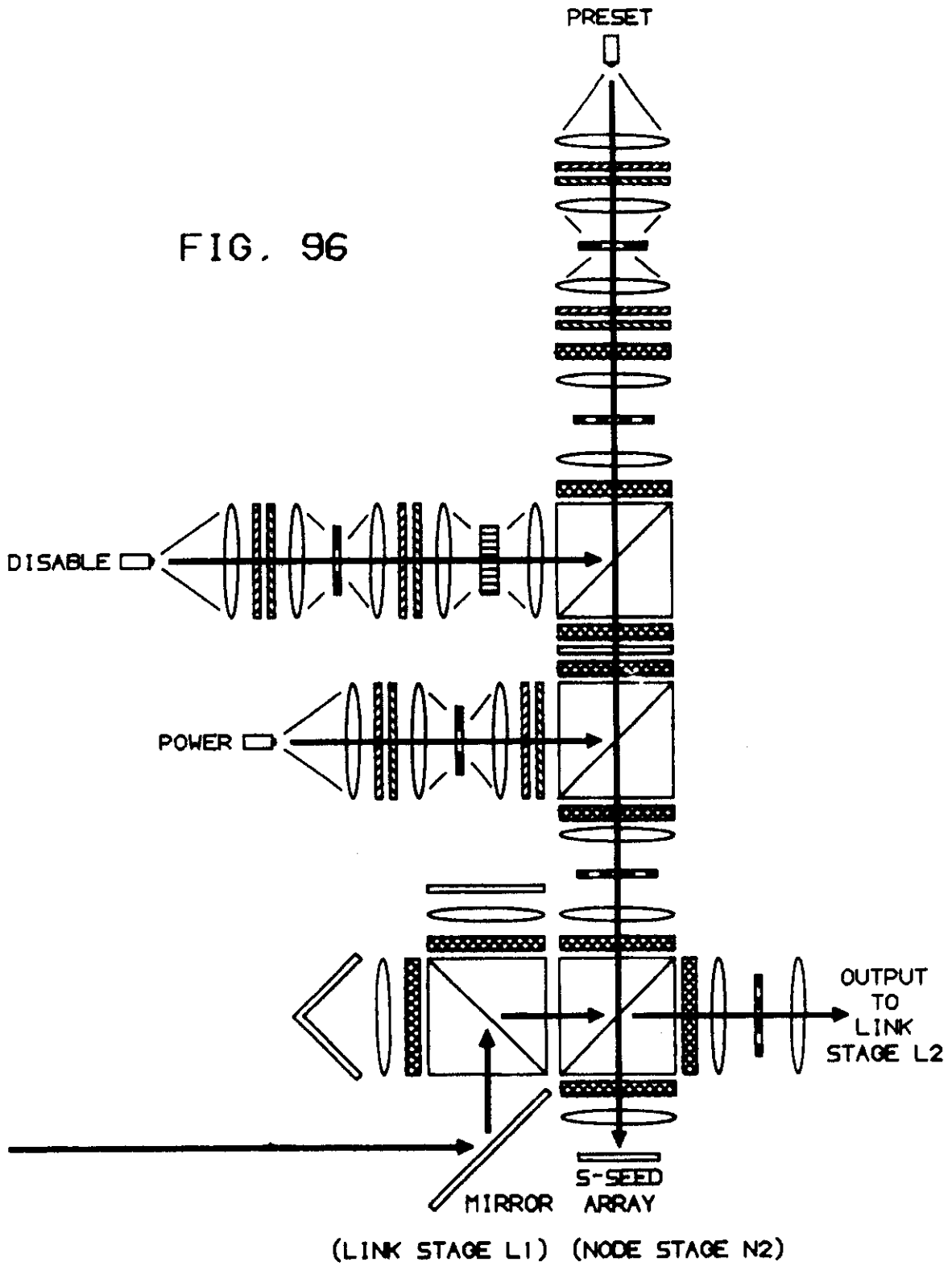
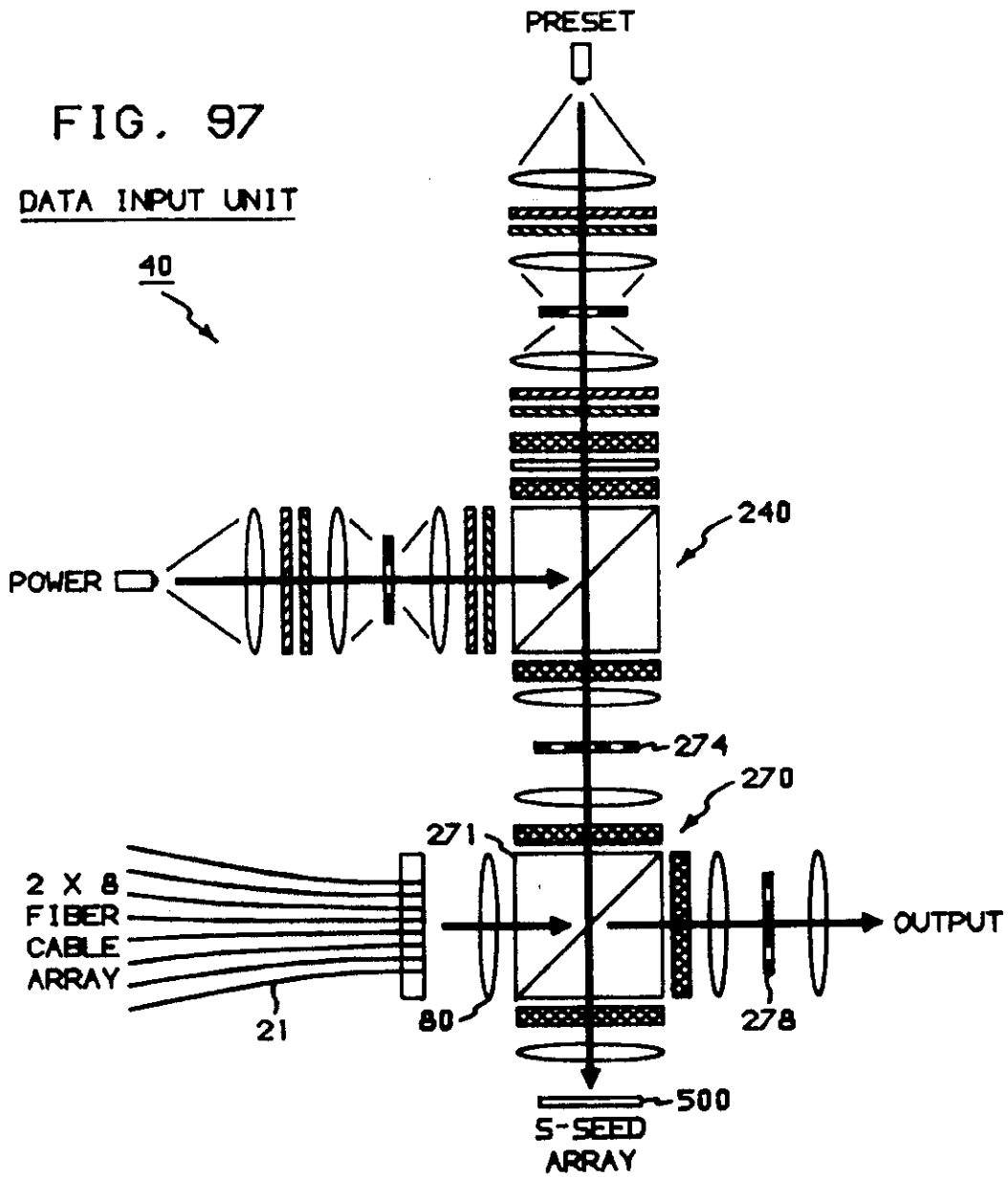

FIG. 97  
DATA INPUT UNIT



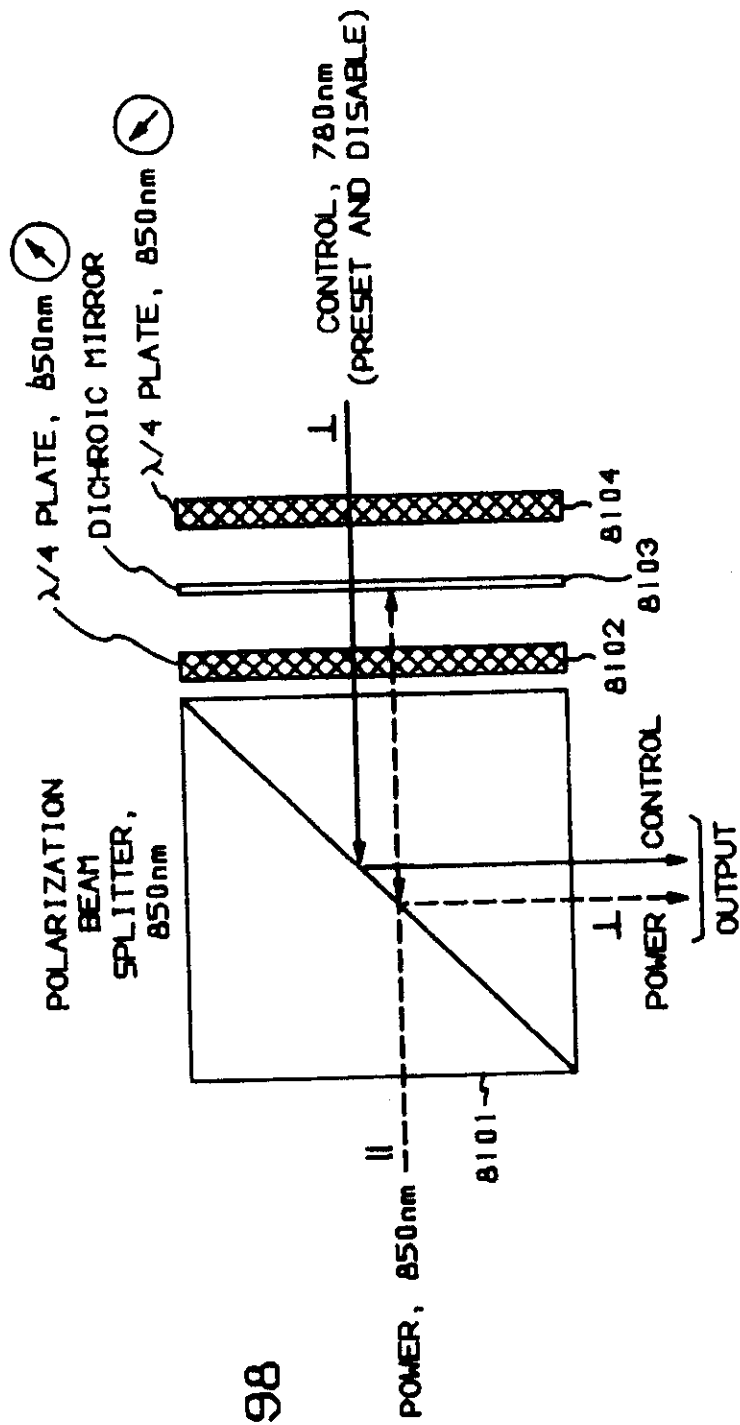

FIG. 98

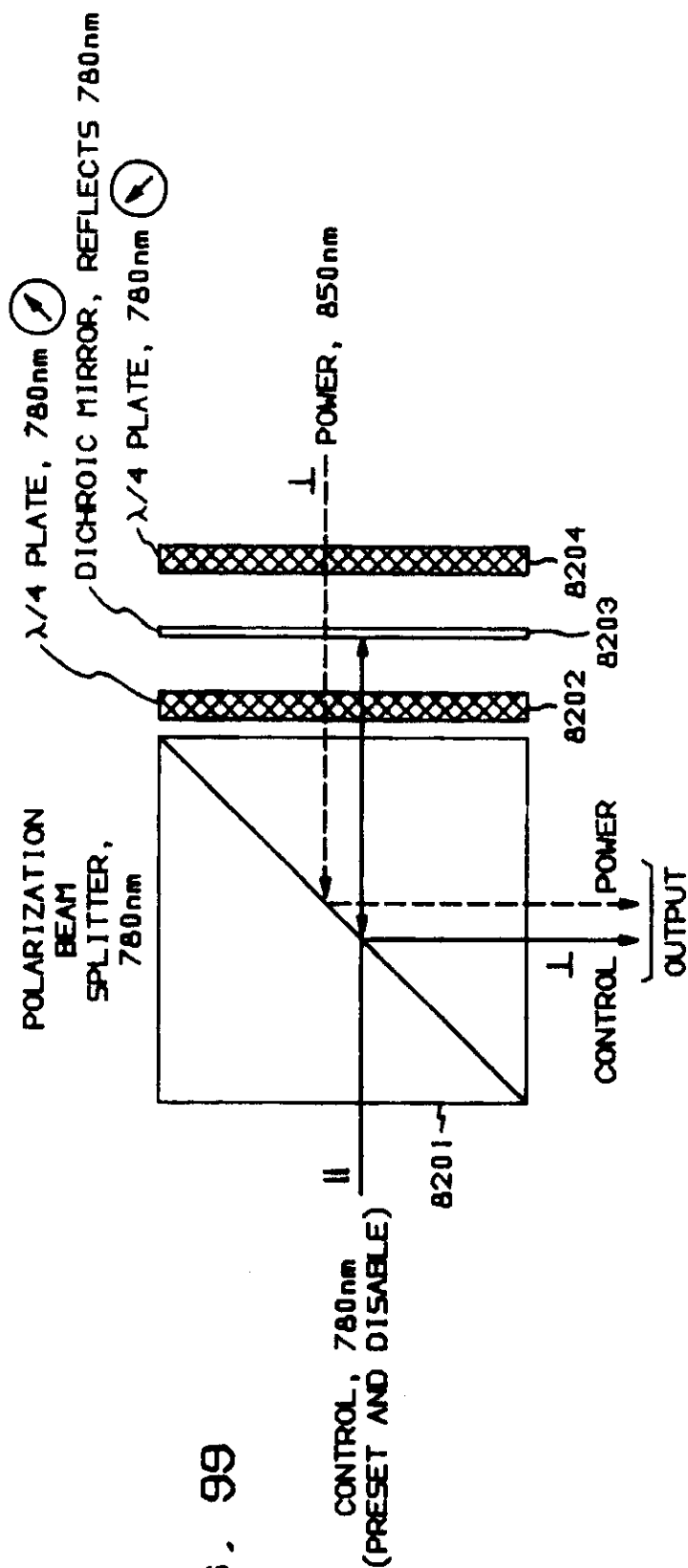

FIG. 99

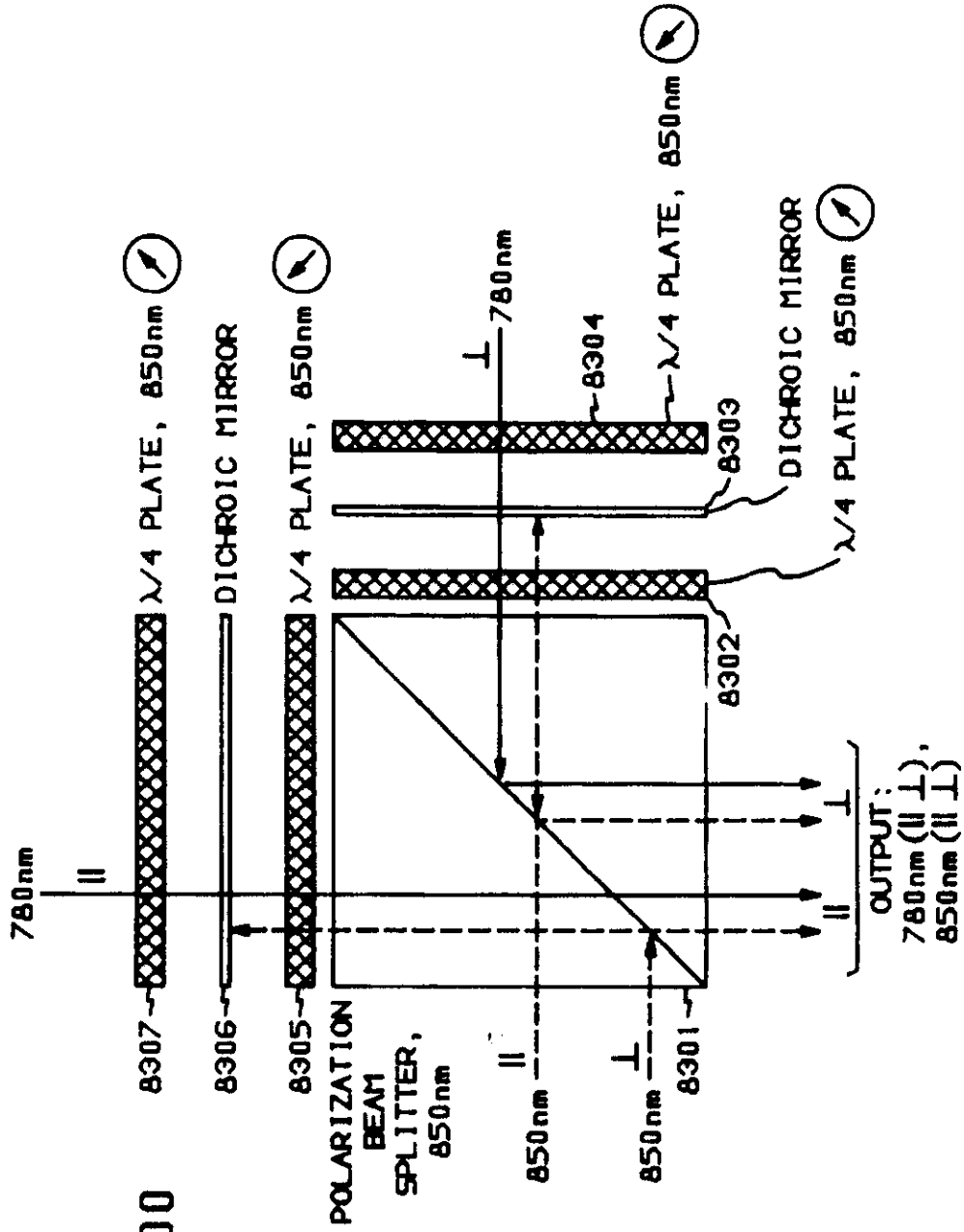

FIG. 100

REGISTER ENTRY FOR EP0397372

European Application No EP90304731.4 filing date 01.05.1990

Priority claimed:

08.05.1989 in United States of America - doc: 349281

Designated States BE DE ES FR GB IT NL

Title NETWORK TOPOLOGY FOR REDUCED BLOCKING AND PHOTONIC SYSTEM IMPLEMENTATION THEREOF.

Applicant/Proprietor

AMERICAN TELEPHONE AND TELEGRAPH COMPANY, 550 Madison Avenue, New York, NY  
10022, United States of America [ADP No. 50209329002]

Inventors

THOMAS J. CLOONAN, 7625 Bainbridge Drive, Downers Grove, Illinois 60516,  
United States of America [ADP No. 57990426001]

STEPHEN J. HINTERLONG, 1729 Richard Street, Aurora, Illinois 60505, United  
States of America [ADP No. 57990491001]

HARVARD S. HINTON, 1229 Calico Avenue, Naperville, Illinois 60565, United  
States of America [ADP No. 57990509001]

FRANK K. HWANG, 139 King George Road, Warren, New Jersey 07060, United  
States of America [ADP No. 57990517001]

JURGEN JAHNS, 194 Garden Road, Shrewsbury, New Jersey 07702, United States  
of America [ADP No. 57990525001]

JACK L. JEWELL, 12 Timberline Drive, Bridgewater, New Jersey 08807, United  
States of America [ADP No. 57990467001]

ANTHONY L. LENTINE, 36W835 Oak Road, St. Charles, Illinois 60175, United  
States of America [ADP No. 57990434001]

JR. FREDERICK B. MCCORMICK, 5905 Meadow Drive, Lisle, Illinois 60532,  
United States of America [ADP No. 57990442001]

DAVID A. B. MILLER, 64 Hance Road, Fairhaven, New Jersey 07704, United  
States of America [ADP No. 57990475001]

MILES J. MURDOCCA, R.D. Nr. 4, Box 380, Jackson, New Jersey 08527, United  
States of America [ADP No. 57990533001]

MICHAEL E. PRISE, 98 W. Highland Avenue, Atlantic Highlands, New Jersey  
07716, United States of America [ADP No. 57990483001]

GAYLORD W. RICHARDS, 7 South 560 Green Acres Drive, Naperville, Illinois  
60540, United States of America [ADP No. 57990459001]

Classified to  
H04Q

Address for Service

AT&T CORP., 32 Avenue of the Americas, New York, NY 10013-2412, United States of America [ADP No. 50209329002]

EPO Representative

CHRISTOPHER SIMON THIRSK BUCKLEY, AT&T (UK) LTD. AT&T Intellectual Property Division 5 Mornington Road, Woodford Green, Essex IG8 OTU, United Kingdom [ADP No. 50001775001]

Publication No EP0397372 dated 14.11.1990

Publication in English

Examination requested 12.12.1990

Patent Granted with effect from 03.08.1994 (Section 25(1)) with title NETWORK TOPOLOGY FOR REDUCED BLOCKING AND PHOTONIC SYSTEM IMPLEMENTATION THEREOF.

---

20.05.1994 Notification from EPO of change of Applicant/Proprietor details from AMERICAN TELEPHONE AND TELEGRAPH COMPANY, 550 Madison Avenue, New York, NY 10022, United States of America [ADP No. 50209329002] to AT&T CORP., 32 Avenue of the Americas, New York, NY 10013-2412, United States of America [ADP No. 50209329002] Entry Type 25.14 Staff ID. RD06 Auth ID. EPT

01.07.1994 Notification from EPO of change of EPO Representative details from CHRISTOPHER SIMON THIRSK BUCKLEY, AT&T (UK) LTD. AT&T Intellectual Property Division 5 Mornington Road, Woodford Green, Essex IG8 OTU, United Kingdom [ADP No. 50001775001] to CHRISTOPHER SIMON THIRSK BUCKLEY, AT&T (UK) LTD., AT&T Intellectual Property Division, 5 Mornington Road, Woodford Green, Essex IG8 OTU, United Kingdom [ADP No. 50001775001] Entry Type 25.14 Staff ID. RD06 Auth ID. EPT

16.08.1994 Notification of change of Address For Service name and address of AT&T CORP., 32 Avenue of the Americas, New York, NY 10013-2412, United States of America [ADP No. 50209329002] to AT&T (UK) LTD, 5 Mornington Road, WOODFORD GREEN, Essex, IG8 OTU, United Kingdom [ADP No. 00053413001] dated 12.08.1994. Official evidence filed on EP0397372 Entry Type 7.1 Staff ID. SA1 Auth ID. AO

\*\*\*\* END OF REGISTER ENTRY \*\*\*\*

OA80-01  
EP

OPTICS - PATENTS

02/09/94 15:16:49  
PAGE: 1

RENEWAL DETAILS

PUBLICATION NUMBER EP0397372

PROPRIETOR(S)

AT&T Corp., 32 Avenue of the Americas, New York, NY 10013-2412,  
United States of America

DATE FILED 01.05.1990

DATE GRANTED 03.08.1994

DATE NEXT RENEWAL DUE 01.05.1995

DATE NOT IN FORCE

DATE OF LAST RENEWAL

YEAR OF LAST RENEWAL 00

STATUS PATENT IN FORCE