

(Model.)

W. A. S. MURPHY.
WASHING MACHINE.

No. 260,704.

Patented July 4, 1882.

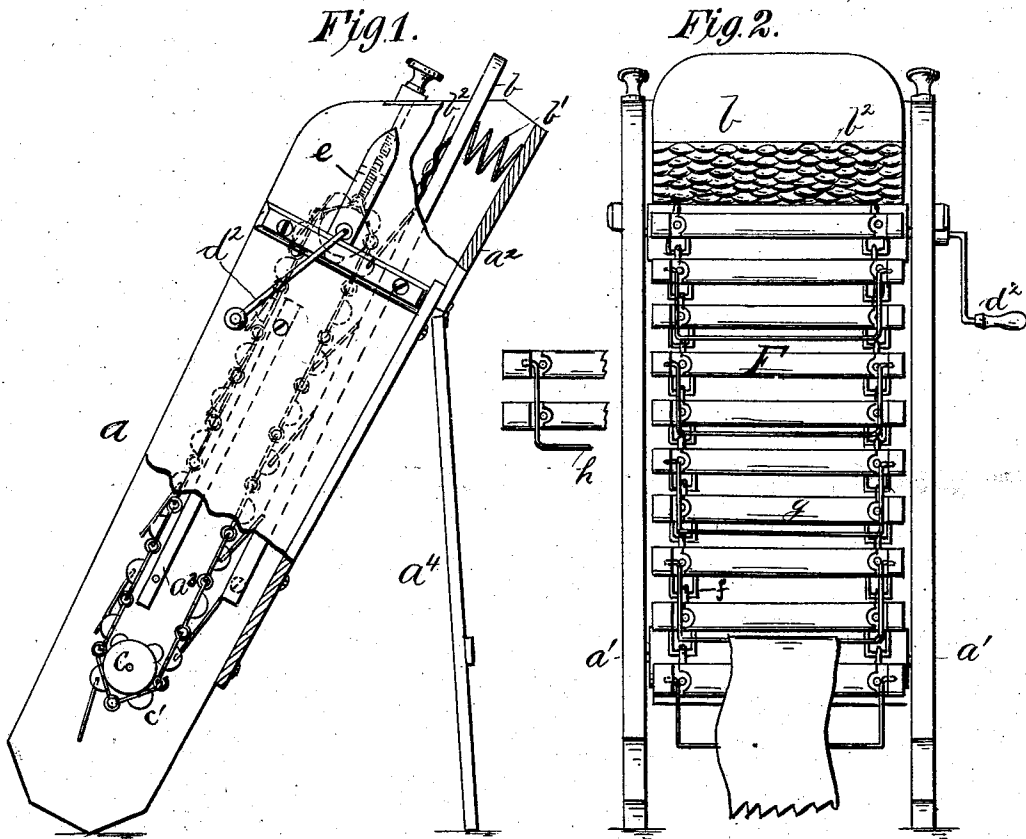

Witnesses:
Cory B. Turpin
F. W. Wheat

Inventor:
Walter A. S. Murphy
By R. S. A. Lacey
Attys:

UNITED STATES PATENT OFFICE.

WALTER A. S. MURPHY, OF CHICAGO, ILLINOIS, ASSIGNOR OF ONE-
FOURTH TO AUGUST LINDALE, OF SAME PLACE.

WASHING-MACHINE.

SPECIFICATION forming part of Letters Patent No. 260,704, dated July 4, 1882.

Application filed September 28, 1881. (Model.)

To all whom it may concern:

Be it known that I, WALTER A. S. MURPHY, a citizen of the United States, residing at Chicago, in the county of Cook and State of Illinois, have invented certain new and useful Improvements in Washing-Machines; and I do hereby declare the following to be a full, clear, and exact description of the invention, such as will enable others skilled in the art to which it

appertains to make and use the same, reference being had to the accompanying drawings, and to letters or figures of reference marked thereon, which form a part of this specification.

This invention relates to improvements in washing-machines.

It consists in the combination, with the endless rubber of a washing-machine, composed of slats having countersinks near their ends and transverse slots across said countersinks, of bails having their arms journaled below the rubbing-surface of the endless rubber and their end parallel arms arranged to drop into the transverse slots in the adjacent slats, and the cross-head to rest in the space between the next adjacent slats, as will be hereinafter fully described, and specifically pointed out in the claims.

In the drawings, Figure 1 is a side view of a machine containing my invention, with lower end of side piece cut away to show endless rubber. Fig. 2 is a front view of same.

a is the frame or casing, consisting of the side boards, *a'* *a'*, and the back board, *a*², and the guide-board *a*³.

*a*⁴ is a support hinged to the back board, *a*², and arranged to support the casing *a* in proper position.

b is a rubbing-board, the lower end of which is hinged near the lower end of the casing, while its upper end is supported by a spring, *b'*, placed between it and the back board, *a*². Part, or all, if desired, of the outer face of the rubber-board is covered with corrugated metal *b*², which provides a good rubbing-surface.

c is a roller journaled in the sides of the casing *a*. Near its lower end, *c'* *c'*, are sprocket-wheels fixed near the ends of roller *c*.

d is a roller journaled in adjustable supports *e*, fixed in the sides of casing *a*, near its top.

d' *d'* are sprocket-wheels fixed near each end of roller *d*.

*d*² is a crank fixed to one end of roller *d*, and extending through the side of the casing. It provides means of communicating motion to the roller *d*.

The roller *d*, being journaled in adjustable supports, may be set to or away from the roller *c*, as desired, so as to tighten or slacken the tension of the belt.

F is an endless rubber, composed of the slats *g*, made nearly the width of the casing *a* and the links *f*, the said slats being riveted to the said links by means of a pin projected from the top of the link and so arranged as to leave a space between them, as shown. The rivet fastening the slat to the link is countersunk in the top of the slat, as shown, and there is formed a transverse slot through the countersink, and sockets are extended horizontally from the sides of the countersink and adapted to receive the turned ends of bars *h'* of bales *h*, hereinafter described, as clearly shown in Figs. 1 and 2. The slats, being arranged with space between them, permit the water to flow readily through from inner side or below the clothing next the slats of the rubber and cleanse thoroughly and equally the inner and outer sides of the clothing looped in the bail.

h is a bail, over which the clothing to be washed is folded, and it is pivoted to one of the slats of the endless rubber. Its length is a little less than that of the slats of the endless rubber, and the ends of its arms *h'* are turned to enter the socket extended from the sides of the countersink, as shown.

In the construction of endless-belt washing-machines of the class to which this belongs, and in which loops are attached to the said endless belt, provision must be made to permit the passage of the loop between the slats and the rubbing-board without interfering with the rubbing-board.

The ends of the parallel arms of the bale are turned to enter the sockets provided in the sides of the countersink, and the arms are extended across the next adjacent slat and rest in the transverse slot across countersink and below level of said slat, and the cross or connecting arm of bail rests in the space between the first and second slats from the one to which the bale is pivoted. In using the device it is customary to fold one ordinary or several small

garments around each bail, and it will be seen that the cross-arm of bail, with articles so folded, will rest down in the space between the slats and below the rubbing-surface of same, and
 5 that no part of the bail is above the upper surface of the slats. Where the bail is pivoted to one slat and rests on top of adjacent slats, the bail will press the rubbing-board away from the slats, and the rubbing capacity will be
 20 thereby diminished. In my device I obviate this difficulty by pivoting the bail down in countersink of one slat and extending it across and resting it down in slot across adjacent slat, with cross-arm rested in space between the
 15 slats, as hereinbefore described, thereby giving the full rubbing force of the device to the garments to be cleansed.

In the operation of my device the frame or casing *a* may be placed in a tub or suds-box, with its upper end extending over the side of same, and the support *a'* resting outside of the tub or suds-box; or the whole device may be
 20 stood in the tub or suds-box, at the option of the user.

25 The operation of my device is readily understood on reference to the drawings forming a part of this specification. The clothing to be washed is looped through the bails, and mo-

tion is communicated by the crank to the roller *d*, which, by sprocket-wheels, operates the endless belt of rubbing-bars, as shown. 30

I am aware that endless belts having loops attached thereto to carry the clothing to be washed are not new, and I do not claim such as my invention. 35

Having thus described my invention, what I claim, and desire to secure by Letters Patent, is—

The combination, with the endless rubber of a washing-machine, composed of slats having countersinks near their ends and transverse slots extended across said countersinks, of a bail having its arms journaled below the rubbing-surface of the endless rubber, and having its end parallel arms arranged to drop into the
 40 transverse slots in the adjacent slats and rest below the surface of said endless rubber, substantially as set forth. 45

In testimony whereof I affix my signature, in presence of two witnesses, on this 5th day of September, 1881. 50

WALTER A. S. MURPHY.

Witnesses:

R. P. SMITH,

CHAS. M. ROGERS.