

**(12) PATENT**  
**(19) AUSTRALIAN PATENT OFFICE**

**(11) Application No. AU 199671122 B2**  
**(10) Patent No. 719408**

(54) Title  
**Systems and methods for making decorative shaped metal cans**

(51)<sup>7</sup> International Patent Classification(s)  
**B21D 051/26**

(21) Application No: **199671122**

(22) Application Date: **1996.09.17**

(87) WIPO No: **WO97/12706**

(30) Priority Data

(31) Number	(32) Date	(33) Country
<b>60/004679</b>	<b>1995.10.02</b>	<b>US</b>
<b>08/542422</b>	<b>1995.11.16</b>	<b>US</b>
<b>08/551073</b>	<b>1995.12.12</b>	<b>US</b>
<b>9603110</b>	<b>1996.02.14</b>	<b>GB</b>
<b>9604784</b>	<b>1996.03.06</b>	<b>GB</b>
<b>08/683575</b>	<b>1996.07.15</b>	<b>US</b>

(43) Publication Date : **1997.04.28**

(43) Publication Journal Date : **1997.06.19**

(44) Accepted Journal Date : **2000.05.11**

(71) Applicant(s)  
**Crown Cork and Seal Company, Inc.**

(72) Inventor(s)  
**Mark W. Hartman; Zeev W. Shore; James J. Tang; Anton A. Aschberger;  
Michael R. Gogola; William O. Irvine; Ralph J. Trnka; Richard O. Wahler;  
Robert A. Winkless; Richard Mark Orlando Golding; David A. Harvey**

(74) Agent/Attorney  
**DAVIES COLLISON CAVE, 1 Little Collins Street, MELBOURNE VIC 3000**

(56) Related Art  
**GB 2224965**  
**US 3757555**



(51) International Patent Classification :  
**B21D 51/26**

A1

(11) International Publication Number: **WO 97/12706**

(43) International Publication Date: 10 April 1997 (10.04.97)

(21) International Application Number: PCT/US96/14914

(22) International Filing Date: 17 September 1996 (17.09.96)

(30) Priority Data:

60/004,679	2 October 1995 (02.10.95)	US
08/542,422	16 November 1995 (16.11.95)	US
08/551,073	12 December 1995 (12.12.95)	US
9603110.9	14 February 1996 (14.02.96)	GB
9604784.0	6 March 1996 (06.03.96)	GB
<del>08/621,795</del>	<del>22 March 1996 (22.03.96)</del>	<del>US</del>
08/683,575	15 July 1996 (15.07.96)	US

(71) Applicant: CROWN CORK & SEAL COMPANY, INC.  
 [US/US]; 9200 Ashton Road, Philadelphia, PA 19136 (US);

*11535 South Central Avenue  
 Alsip IL 60803  
 United States of America*

(72) Inventors: HARTMAN, Mark, W.; 5 Rivers Edge, Lambertville, NJ 08530 (US). SHORE, Zeev, W.; Unit 402, 18600 Village Drive, Hazel Crest, IL 60429 (US). TANG, James, J.; 833 S. Elm Street, Palatine, IL 60067 (US). ASCHBERGER, Anton, A.; 6661 Barrett Street, Downers Grove, IL 60516 (US). GOGOLA, Michael, R.; 15421 Walnut Road, Oak Forest, IL 60452 (US). IRVINE, William, O.; 11852 Lillis Lane, Golden, CO 80403 (US). TRNKA, Ralph, J.; 8917 Mallard Road, Tinley Park, IL 60477 (US). WAHLER, Richard, O.; 646 East Pompano Lane, Palatine, IL 60067 (US). WINKLESS, Robert, A.; 10128 Kenton Avenue, Oak Lawn, IL 60453 (US). GOLDING, Richard, Mark, Orlando; 10 S. 646 Lilac Lane #212, Hinsdale, IL 60521 (US). HARVEY, David, A.; 43 Woodhill Drive, Grove, Wantage, Oxon OX12 0DE (GB).

(74) Agents: HEIST, Dale, M. et al.; Woodcock Washburn Kurtz Mackiewicz & Norris, 46th floor, One Liberty Place, Philadelphia, PA 19103 (US).

(81) Designated States: AL, AM, AT, AU, AZ, BB, BG, BR, BY, CA, CH, CN, CU, CZ, DE, DK, EE, ES, FI, GB, GE, HU, IL, IS, JP, KE, KG, KP, KR, KZ, LK, LR, LS, LT, LU, LV, MD, MG, MK, MN, MW, MX, NO, NZ, PL, PT, RO, RU, SD, SE, SG, SI, SK, TJ, TM, TR, TT, UA, UG, UZ, VN, ARIPO patent (KE, LS, MW, SD, SZ, UG), Eurasian patent (AM, AZ, BY, KG, KZ, MD, RU, TJ, TM), European patent (AT, BE, CH, DE, DK, ES, FI, FR, GB, GR, IE, IT, LU, MC, NL, PT, SE), OAPI patent (BF, BJ, CF, CG, CI, CM, GA, GN, ML, MR, NE, SN, TD, TG).

Published  
 With international search report.

(54) Title: SYSTEMS AND METHODS FOR MAKING DECORATIVE SHAPED METAL CANS

(57) Abstract

A method of manufacturing a metallic can body (24) that is shaped distinctively in order to enhance its visual presentation to consumers includes, in one embodiment, steps of providing a can body blank (10) that has a sidewall that is of a substantially constant diameter; providing a mold unit (38) that has at least one mold wall (46) that defines a mold cavity conforming a desired final shape of the can body (24); positioning the can body blank (10) within the mold cavity (46); and supplying a pressurized fluid into the mold cavity so that the can body blank (10) is forced by pressure against the mold wall (46), causing the can body blank (10) to assume the desired final shape of the can body (24). Axial compression is preferably applied to the can body blank in order to reduce internal stresses during molding of the container. A second embodiment includes steps of radially deforming the can body blank in selected areas by selected amounts to achieve an intermediate can body that is radially modified, but is still symmetrical about its axis; and superimposing a preselected pattern of mechanical deformations that have an axial component onto the intermediate can body. Related apparatus and processes are also disclosed.

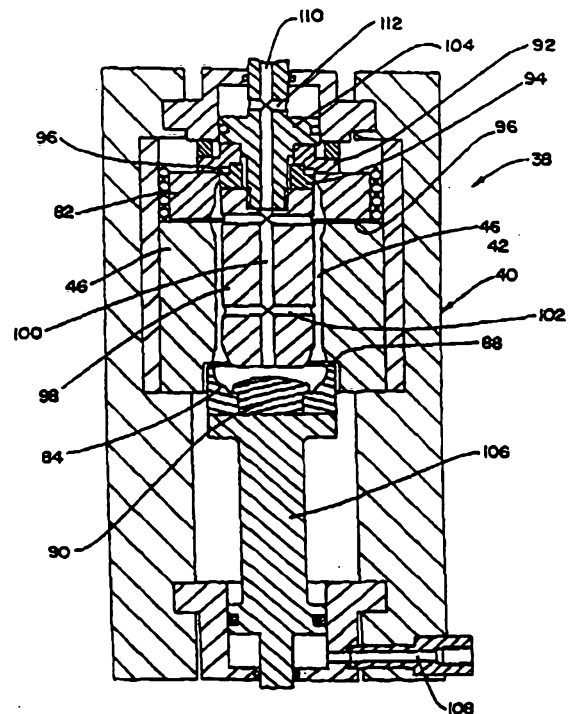

*see folio 5*  
  
*see folio 7*



# SYSTEMS AND METHODS FOR MAKING DECORATIVE SHAPED METAL CANS

## BACKGROUND OF THE INVENTION

### 1. Field of the Invention

5 This invention relates generally to the field of consumer packaging, and more specifically to metal cans, such as the steel and aluminum cans that are commonly used for packaging soft drinks, other beverages, food and aerosol products.

### 2. Description of the Prior Art and Recent Technology

10 Metal cans for soft drinks, other beverages and other materials are of course in wide use in North America and throughout the world. The assignee of this invention, Crown Cork & Seal Company of Philadelphia, is the world's largest designer and manufacturer of such cans.

The art of making and packing metal cans is constantly evolving in response to improved technology, new materials, and improved manufacturing techniques. 15 Other forces driving the evolution of technology in this area include raw material prices, the nature of new materials to be packaged and the marketing goals of the large companies that manufacture and distribute consumer products such as soft drinks.

Interest has existed for some time for a metal container that is shaped differently than the standard cylindrical can in such a distinctive way to become part of the 20 product's trade dress, or to be otherwise indicative of the source or the nature of the product. To the inventors best knowledge, however, no one has yet developed a practical technique for manufacturing such an irregularly shaped can at the volume and speed that would be required to actually introduce such a product into the marketplace.

U.S. Patent 3,224,239 to Hansson, which dates from the mid 1960's, 25 discloses a system and process for using pneumatic pressure to reshape cans. This process

utilized a piston to force compressed air into a can that is positioned within a mold. The compressed air caused the can wall to flow plastically until it assumed the shape of the mold.

Technology such as that disclosed in the Hansson patent has never, to the knowledge of the inventors, been employed with any success for the reshaping of drawn and wall ironed cans. One reason for this is that the stress that is developed in the wall of the can as it is being deformed can lead to defects that are potentially failure-inducing, e.g., localized thinning, splitting or cracking. The risk of thinning can be reduced by increasing the wall thickness of the can, but this would make shaped cans so produced prohibitively expensive. The risk of splitting and cracking can be reduced by a process such as annealing, but at the expense of reduced toughness and abuse resistance of the final product.

A need exists for an improved apparatus and process for manufacturing a shaped metal can design, that is effective, efficient and inexpensive, especially when compared to technology that has been heretofore developed for such purposes, and that reduces the tendency of a shaped can to fail as a result of thinning, splitting or cracking.

#### SUMMARY OF THE INVENTION

Accordingly, the invention advantageously provides an improved apparatus and process for manufacturing a shaped metal can that is effective, efficient and inexpensive, especially when compared to technology that has been heretofore developed for such purposes, and that provides insurance against internal stresses within the can that could cause thinning, splitting or cracking.

In order to achieve the above and other advantages of the invention, a method of manufacturing a metallic can body that is shaped distinctively in order to enhance its visual presentation to consumers, includes, according to a first aspect of the invention, steps of: (a) providing a can body blank; (b) providing a mold unit that has at least one mold wall that defines a mold cavity conforming to a desired final shape of the can body the mold unit being constructed of more than one part, at least one of the parts being movable toward another in a direction that is substantially parallel to an axis of the can body blank during operation, the mold wall including inwardly extending portions and outwardly extending portions; (c) positioning the can body blank within the mold cavity so as to precompress the can body blank with the inwardly extending portions of the mold

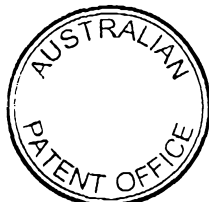

5 wall; (d) supplying a pressurized fluid into the mold cavity so that the can body blank is forced by pressure against the mold wall, causing the can body blank to assume the desired final shape of the can body, the precompression that is performed in step (c) minimizing the amount of outward deformation that is required to achieve the final shape of the can body; and (e) substantially simultaneously with step (d), moving at least one of the mold parts toward another in the axial direction.

10 According to a second aspect of the invention, a method of manufacturing a metallic can body that is shaped distinctively in order to enhance its visual presentation to consumers, includes steps of: (a) making a can body blank; (b) at least partially annealing at least a portion of the can body blank, thereby giving the annealed portion of the can body blank increased ductility; (c) providing a mold unit that has at least one mold wall that defines a mold cavity conforming to a desired final shape of the can body, the mold unit being constructed of more than one part, at least one of the parts being movable toward another in a direction that is substantially parallel to an axis of the can body blank during operation; (d) positioning the can body blank within the mold cavity; (e) supplying a pressurized fluid into the mold cavity so that the can body blank is forced by pressure against the mold wall, causing the can body blank to assume the desired final shape of the can body; and (f) substantially simultaneously with step (e), moving at least one of the mold parts toward another in the axial direction.

20 According to a third aspect of the invention, an apparatus for manufacturing a metallic can body that is shaped distinctively in order to enhance its visual presentation to consumers includes structure for making a can body blank; molding structure comprising a mold unit that has at least one mold wall that defines a mold cavity conforming a desired final shape of the can body, said mold wall comprising inwardly extending portions and outwardly extending portions, the mold unit being constructed of more than one part, at least one of the parts being movable toward another in a direction that is substantially parallel to an axis of the can body blank during operation; positioning structure for positioning the can body blank within the mold cavity so as to precompress the can body blank by the inwardly extending portions of the mold wall; fluid supply structure for supplying a pressurized fluid into the mold cavity so that the can body blank is forced by pressure against the mold wall, causing the can body blank to assume the desired final shape of the can body, the precompression minimizing the amount of outward

25

30

deformation that is required to achieve the final shape of the can body; and axial reduction structure for moving at least one of the mold parts toward another in the axial direction.

According to a fourth aspect of the invention, an apparatus for manufacturing a metallic can body that is shaped distinctively in order to enhance its visual presentation to consumers includes structure for making a can body blank; structure  
5 for at least partially annealing at least a portion of the can body blank, thereby giving the annealed portion of the can body blank increased ductility; mold structure comprising a mold unit that has at least one mold wall that defines a mold cavity conforming to a desired final shape of the can body, the mold unit being constructed of more than one part,  
10 at least one of the parts being movable toward another in a direction that is substantially parallel to an axis of the can body blank during operation; positioning structure for positioning the can body blank within the mold cavity; fluid supply structure for supplying a pressurized fluid into the mold cavity so that the can body blank is forced by pressure against the mold wall, causing the can body blank to assume the desired final  
15 shape of the can body; and axial reduction structure for moving at least one of the mold parts toward another in the axial direction..

In another aspect the invention provides a method of reshaping a hollow can body blank that is used to make a can body, comprising:

placing the can body blank into a chamber defined by a mold having three parts;  
20 supplying a pressurized fluid to the interior cavity of the hollow can body blank to expand the can body blank radially outwards onto the inner surface of the mold; and  
moving two of the mold parts towards the third from a first position in which the parts are spaced from each other by gaps which open into the mold chamber to a second position in which the gaps between the mold parts are reduced in size whilst still opening into the mold  
25 chamber.

In a further aspect the invention provides an apparatus for reshaping a hollow can body blank comprising:

a mold having three parts defining a chamber to accommodate the can body blank;  
means for supplying a pressurized fluid to the interior cavity of the hollow can body  
30 blank to expand the can body blank radially outwards onto the inner surface of the mold; and  
means for moving two of the mold parts towards the third from a first position in which the parts are spaced from each other by gaps which open into the mold chamber to a second position in which the gaps between the mold parts are reduced in size whilst still

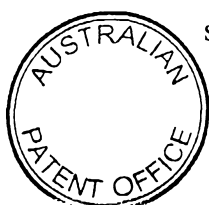

opening into the mold chamber.

In yet another aspect the invention provides a method of reshaping a two piece can into a shape having two or more enlarged regions, the method comprising:

placing the can body blank into a chamber defined by a mold having three parts spaced  
5 from each other by gaps which open into the mold chamber and each of which is at, or substantially at, the position of maximum expansion of one of the enlarged regions;

supplying a pressurized fluid to the interior cavity of the hollow can body blank to expand the can body blank radially outwards onto the inner surface of the mold; and  
moving two of the mold parts towards the third as the can is being expanded.

10

These and various other advantages and features of novelty which characterize the invention are pointed out with particularity in the claims annexed hereto and forming a part hereof. However, for a better understanding of the invention, its advantages, and the objects obtained by its use, reference should be made to the drawings which form a further part hereof, and to the accompanying descriptive matter, in which there is illustrated and described a preferred embodiment of the invention.

**BRIEF DESCRIPTION OF THE DRAWINGS**

FIGURE 1 is a cross-sectional view taken through a can body blank or pre-form that is constructed according to a preferred embodiment of the invention;

FIGURE 2 is a side elevational view of a shaped can body according to a preferred embodiment of the invention;

FIGURE 3 is a diagrammatical view of An apparatus for making a shaped can body according to a preferred embodiment of the invention;

FIGURE 4 is a fragmentary cross-sectional view through a mold unit in the apparatus depicted in FIG. 3, shown in a first condition;

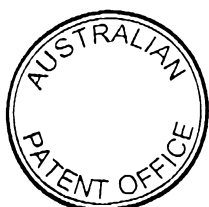

- 5 -

FIGURE 5 is a fragmentary cross-sectional view through a mold unit in the apparatus depicted in FIG. 3, shown in a second condition;

FIGURE 6 is a schematic diagram depicting a pressure supply apparatus for the mold unit depicted in FIG. 3;

5 FIGURE 7 is diagrammatical depiction of a precompression step that is performed in the apparatus as depicted in FIG. 3;

FIGURE 8 is a diagrammatical depiction of a beading step in a method that is performed according to a second embodiment of the invention;

10 FIGURE 9 is a diagrammatical depiction of a spinning step in a method that is performed according to a second embodiment of the invention; and

FIGURE 10 is a diagrammatical depiction of a knurling step that can be performed as a second step in either the second or third embodiments of the invention referred to above.

#### **DETAILED DESCRIPTION OF THE PREFERRED EMBODIMENT(S)**

15 Referring now to the drawings, wherein like reference numerals designate corresponding structure throughout the views, and referring in particular to Figures 1 and 2, a can body blank or preform 10 according to a preferred embodiment of the invention is the body of a two-piece can, which is preferably formed by the well-known drawing and ironing process. Can body blank 10 includes a substantially cylindrical sidewall surface  
20 12, a bottom 14, and necked upper portion 16. Alternatively, the upper portion of cylindrical sidewall 12 could be straight.

As is well known in this area of technology, the can body blank 10 must be washed after the drawing and ironing process, and then must be dried prior to being sent to the decorator. The drying process typically is performed at a temperature of about 250  
25 degrees Fahrenheit (which is about 121 degrees Celsius). According to one aspect of this invention, the drying is performed at a higher temperature than is ordinary to partially anneal at least selected portions of the can body blank 10. In Figure 1, a heat source 18 is schematically depicted, which is preferably part of the dryer assembly, but could be at any point in the apparatus prior to the molding unit. As will be discussed in greater detail  
30 below, can body blank 10 is preferably formed of aluminum and the partial annealing is preferably accomplished at a temperature that is substantially within the range of about 375 degrees Fahrenheit (about 190.5 degrees Celsius) to about 550 degrees Fahrenheit

- 6 -

(about 288 degrees Celsius), with a more preferred range of about 450 degrees Fahrenheit (about 232 degrees Celsius) to about 500 degrees Fahrenheit (about 260 degrees Celsius), and a most preferred temperature of about 475 degrees Fahrenheit (about 246 degrees Celsius). This is in contrast to true annealing, which would be at temperatures over 650  
5 degrees Fahrenheit (about 353 degrees Celsius). The purpose of the partial annealing is to give the can body blank 10 enough ductility to be formed into a shaped can 20, such as is shown in Figure 2 of the drawings, but greater toughness than would be possible if the can body blank were fully annealed.

Alternatively, the partial annealing could be performed in an oven such as  
10 the lacquer or decorator oven, rather than in the dryer.

Alternatively, can body blank 10 could be fabricated from steel instead of aluminum. In this case, the preferred temperature range for partial annealing would be substantially within the range of 1112 degrees Fahrenheit (600 degrees Celsius) to about 1472 degrees Fahrenheit (800 degrees Celsius). More preferably, the partial annealing  
15 would be performed at approximately 1382 degrees Fahrenheit (750 degrees Celsius).

Referring now to Figure 2, shaped can 20 is decorated and shaped distinctively in order to enhance its visual presentation to consumers. As may be seen in Figure 2, can body 20 includes a bottom 26, a shaped sidewall 22 that is shaped to substantially deviate from the standard cylindrical can body shape, such as the shape of  
20 can body blank 10. The shaped sidewall 22 includes areas, such as ribs 30 and grooves 32, where accentuation of such deviations from the cylindrical shape might be desired. According to one important aspect of the invention, decoration is provided on the external surface of the shaped sidewall 22 in a manner that will accentuate those areas of the sidewall where accentuation of the deviation from the cylindrical shape is desired. As  
25 may be seen in Figure 2, a first type of decoration, which may be a lighter color, is provided on the rib 30, while a second type of decoration 36, which may be a darker color, is provided within at least one of the grooves 32. By providing such selective decoration, and by properly registering the decoration to the deviations in the shaped sidewall 22, a synergistic visual effect can be obtained that would be impossible to obtain alone by  
30 shaping the can or by decorating the can.

- 7 -

Referring again to Figure 2, shaped sidewall 22 also has a flat area 28, where writing or a label might be applied, and is closed by a can end 24, which is applied in the traditional double seaming process.

According to the preferred method, after the partial annealing by the heat source 18 at the drying station, can body blank 10 will be transported to a decorator, where the distinctive decoration will be applied while the can body blank 10 is still in its cylindrical configuration. Markers might also be applied during the decorating process that can be used for registration of the decoration to the mold contours during subsequent forming steps, which will be described in greater detail below.

Referring now to Figure 3, An apparatus 38 is depicted which, according to the preferred embodiment of the invention, is provided to manufacture a shaped can 20 of the type that is depicted in Figure 2. As may be seen in Figures 3, 4 and 5, apparatus 38 includes a mold 40 having a mold wall 46 that defines a mold cavity 42 conforming to the desired final shape of the shaped can body 20. As is shown diagrammatically in Figure 7, the mold 40 is of the split wall type and the mold wall 46 will include inwardly extending portions 48 that are less in diameter than the diameter  $D_0$  of the cylindrical sidewall 12 of the can body blank 10 depicted by the dotted lines in Figure 7b. The mold wall 46 will also include a number of outwardly extending portions that are greater in diameter than the diameter  $D_0$  of the sidewall 12 of the can body blank 10. In other words, the inwardly extending portions 48 tend to compress the cylindrical sidewall 12 of the can body blank 10 to the position 12' shown by the solid lines in Figure 7b, while the sidewall 12 of the can body blank 10 must be expanded to conform to the outwardly extending portions 50 of the mold wall 46. Preferably, the perimeter of the cylindrical sidewall remains a constant length when compressed in this manner so the perimeter of the cylindrical compressed sidewall 12' is the same length as the circumference of the sidewall 12 of the can body blank 10.

As is best shown in Figure 3, the mold unit 40 has three die parts 82, 46 and 84 which comprise neck ring, mold side wall and base support, respectively. The die parts are separated from each other by gaps or "split lines" 86 and 88. For ease of machining, the base support die 84 is made in two parts, with a central part 90 supporting the base dome of the can body. The neck ring 82 provides simple support to the necked portion of the can body. These components together define the chamber or mold cavity 42 to receive

the can body and are machined to the desired final shape of the can body after blow forming. Vent holes 49 are provided (see Figures 4 and 5) to allow trapped air to escape during forming.

A pair of seal and support rings 92, 94 and a rubber sealing ring 96 are  
5 provided to seal the top edge of the container body. A space saving mandrel 98 passes through the center of the seal and support rings 92, 94, 96 to a position just above the base support dome 84. The mandrel 98 supplies air to the cavity of a can body within the cavity 42 via a central bore 100 and radial passages 102. The apparatus further includes an upper piston and a lower piston 104, 106 which together apply a load to both ends of the can in  
10 the mould cavity 42. Lower piston 106 is moveable upwards by structure of a pressurized air supply which is fed to the piston via passage 108. Similarly, the upper piston is moveable downwards by structure of a pressurized air supply which is fed to the piston via passages 110 and 112. In the preferred embodiment shown, the passage 110 is connected to the central bore 100 of the mandrel 98 so that the upper piston and can cavity share a  
15 common air supply. The common air supply is split for the piston 104 and cavity at the junction of the air passage 112 and the central mandrel bore 100, within the piston 104 so as to minimize losses and to maintain the same pressure supplied to the cavity and piston. Preferably, means are provided to control the flow rate of air supplied to each piston and the cavity. Cavity pressure and piston pressure can therefore be closely controlled.

20 A schematic circuit diagram which shows how air is supplied to the pistons and can cavity is shown in figure 6. In the figure, the upper piston 104 and seal and support rings 92,94 are shown schematically as a single unit 114. Likewise, the base support 84,90 and lower piston 106 are shown as a single unit 116. Units 114 and 116 and neck ring 82 are movable, whereas the side wall die 46 of the mold is shown fixed.

25 The circuit comprises two pressure supplies. Pressure supply 118 supplies pressurised air to the top piston 104 and cavity of the can within the mold cavity 42. Pressure supply 120 supplies pressurised air to the lower piston 106 only.

The two supplies each comprise pressure regulators 122,124, reservoirs 126,128, blow valves 130,132 and exhaust valves 134,136. In addition, the lower pressure  
30 supply 120 includes a flow regulator 138. Optionally, the upper pressure supply 118 may also include a flow regulator, although it is not considered essential to be able to adjust the

flow in both supplies. Reservoirs 126, 128 prevent a high drop in supply pressure during the process.

Typically, high pressure air of around 30 bar is introduced to the can cavity and to drive the top of the can. The air pressure to drive the bottom piston 106 is typically  
5 around 50 bar, depending on the piston area. The air pressure within the mold cavity 42 provides the force which is required to expand the can body blank outwards but also applies an unwanted force to the neck and base of the can which leads to longitudinal tension in the can side wall. The two pistons are thus used to drive the top and the bottom of the can, providing a force which counteracts this tension in the can side wall.

10 The pressure of the air supplied to the pistons is critical in avoiding failure of the can during forming due to either splitting or wrinkling. Splitting will occur if the tension in the can side wall is not sufficiently counteracted by the piston pressure, since the pressure in the pistons is too low. Conversely, the pressure of the air supplied should not be so high that this will lead to the formation of ripples in the side wall.

15 For this reason, preferably no stops are required to limit the stroke of the pistons. If the stroke were limited, the can might not be fully expanded against the mould wall before the pistons reached the stops. If this occurs, the tension in the can side wall would cease to be balanced by the piston pressure with a consequent risk of splitting. In effect, the contact of the expanded can with the side wall of the mould prevents further  
20 movement of the pistons.

It should be noted therefore that the balance between the can cavity pressure and the piston pressure is preferably maintained at all times throughout the forming cycle so that the rate of pressure rise in the cavity and behind the pistons should be balanced throughout the cycle, particularly when the can wall yields. The rate of  
25 pressure rise can be controlled by the flow regulator 138 or by adjusting the supply pressure via the pressure regulators 122,124.

By adjusting the can cavity pressure versus the pressure that is applied to move the mold elements 82, 46, 84 towards one another, the apparatus may be operated in one of three different ways. By minimizing application of pressure to the outer mold parts  
30 82,84, the apparatus may be operated so as to simply move the mold parts toward another without exerting any force on the can body. This will reduce the gaps 86, 88 in the mold unit 40 as the can body shrinks longitudinally during the expansion process, and will

- 10 -

reduce but not necessarily neutralize axial tensile stress created in the sidewall of the can body during expansion. Alternatively, by providing increased pressure to drive the outer mold parts toward one another, a slight longitudinal or axial force is applied to the can body which is substantially equal to the axial tensile stress in the can body sidewall, thus  
5 balancing such stress and protecting the can body from consequential weakening and possible splitting. A third mode of operation would be to provide an even greater pressure to drive the outer mold parts toward one another in order to apply an axially compressive force to the can body that would be greater than what would be necessary to cancel the tensile stress in the sidewall during operation. A net compressive force is believed to be  
10 preferable provided that such a force does not lead to the formation of wrinkles.

In order to form the can, the blow valves 130,132 are first opened. It is possible to have a short delay between the opening times of the blow valves if required to obtain a better match between the piston and cavity pressures but there will then need to be a higher rate of pressure rise for one circuit in order to maintain this balance. A delay  
15 can also be used to compensate for different pipe lengths, maintaining a pressure balance at the time of forming. The upper supply 118 is split for the piston 104 and cavity as close as possible to the piston 104 as described above in reference to Figure 3.

The apparatus is designed so that, at the latest, when each piston reaches its maximum travel the can is fully reshaped and the gaps 86, 88 are not closed up at the end.  
20 Closing of the gaps can lead to splitting of the can due to excessive tension in the side wall in the same way as does limiting movement of the pistons before full expansion has occurred. However, the final gap should not be excessive since any witness mark on the side wall becomes too apparent, although removal of sharp edges at the split lines alleviates this problem.

25 Once the shaping operation is completed, the air is exhausted via valves 134 and 136. Clearly the exhaust valves are closed throughout the actual forming process. It is important that both supplies are vented simultaneously since the compressive force applied by the pistons to balance the cavity pressure (longitudinal tension) may be greater than the axial strength of the can so that uneven exhausting leads to collapse of the can.

30 As may best be seen in Figure 4, the can body blank 10 is preferably positioned within the mold cavity 42 and its interior space is sealed into communication with a source of pressurized fluid, as described above. As may be seen in Figure 4, the

cavity 42 is designed so as to impart a slight compression to the can body blank 10 as it is inserted therein. This is preferably accomplished by forming the mold assembly elements into halves 52, 54, shown in Figure 4 that are split so as to be closeable about the can body blank prior to pneumatic expansion of the can body blank 10.

5                   As the mold halves 52, 54 close about the cylindrical sidewall 12, the inwardly extending portions 48 of the mold wall 46 thus compress or precompress the cylindrical sidewall 12 by distances up to the amount  $R_{in}$ , shown in Figure 7. After the mold has been closed and sealed and pressurized fluid is supplied into the mold cavity 46 so as to force the can body blank 10 against the mold wall 46, can body blank 10 will be  
10 forced to assume the desired final shape of the shaped can 20. The state of the shaped sidewall 22 is shown after the step in Figure 5. In this step, the cylindrical sidewall 12 of the can body blank 10 is expanded up to an amount  $R_{out}$ , again shown diagrammatically in Figure 7.

                  Preferably, the precompression that is effected by the closing of the mold  
15 halves 52, 54 is performed to deflect the sidewall 12 of the can body blank 10 radially inwardly by a distance of  $R_{in}$  that is within the range of about 0.1 to about 1.5 millimeters. More preferably, this distance  $R_{in}$  is within the range of 0.5 to about 0.75 millimeters. The distance  $R_{out}$  by which cylindrical sidewall 12 is radially expanded outwardly to form the outermost portions of the shaped sidewall 22 is preferably within the range of about 0.1 to  
20 about 5.0 millimeters. A most preferable range for distance  $R_{out}$  is about 0.5 to 3.0 millimeters. Most preferably,  $R_{out}$  is about 2 millimeters.

                  To understand the benefit that is obtained by the precompression of the cylindrical sidewall 12 prior to the expansion step, it must be understood that a certain amount of annealing or partial annealing may be useful, particularly in the case of  
25 aluminum can bodies, to obtain the necessary ductility for the expansion step. However, the more complete the annealing, the less strong and tough the shaped can 20 will ultimately be. By using the precompression to get a significant portion of the differential between the innermost and outermost portions of the pattern that is superimposed onto the final shaped can 20, the amount of actual radial expansion necessary to achieve the desired  
30 pattern is reduced. Accordingly, the amount of annealing that needs to be applied to the can body blank 10 is also reduced. The precompression step, then, allows the desired pattern to be superimposed on the shaped can 20 with a minimum of annealing and

- 12 -

resultant strength loss, thus permitting the cylindrical sidewall 12 of the can body blank 10 to be formed as thinly as possible for this type of process.

As one embodiment of the invention, the mold wall may be formed of a porous material so as to allow air trapped between the sidewall of the can body blank and the mold wall to escape during operation, although vent holes will probably still be  
5 required. One such material is porous steel, which is commercially available from AGA in Leydig, Sweden.

For purposes of quality monitoring and control, fluid pressure within the mold cavity 46 is monitored during and after the expansion process by structure of a  
10 pressure monitor 69, shown schematically in Figure 5. Pressure monitor 69 is of conventional construction. If the can body develops a leak during the expansion process, or if irregularities in the upper flange or neck of the can creates a bad seal with the gas probe, pressure within the mold cavity will drop much faster in the mold chamber 46 than would otherwise be the case. Pressure monitor 69 will sense this, and will indicate to an  
15 operator that the can body might be flawed.

In the case of steel cans, pressure within the mold chamber could be made high enough to form the can body into, for example, a beading-type pattern wherein a number of circumferential ribs are formed on the container.

A second method and apparatus for manufacturing a metallic can body that  
20 is shaped distinctively in order to enhance its visual presentation to consumers is disclosed in Figures 7 and 9 of the drawings. A third embodiment is depicted in Figures 8 and 9 of the drawings. According to both the second and third embodiments, a distinctively shaped metallic can body is manufactured by providing a can body blank, such as the can body blank 10 shown in Figure 1, that has a sidewall 12 of substantially constant diameter, then  
25 radially deforming the can body blank 10 in selective areas by selected amounts to achieve an intermediate can body 74 that is radially modified, but is still symmetrical about its axis, and then superimposing a preselected pattern of mechanical deformations onto the intermediate can body 74. Describing now the second embodiment of the invention, a beading apparatus 62 of the type that is well known in this area of technology includes an  
30 anvil 66 and a beading tool 64. A beading apparatus 62 is used to radially deform the can body blank 10 into the radially modified intermediate can body 74 shown in Figure 9. The intermediate can body 74, as may be seen in Figure 9, has no deformations thereon that

have an axial component, and is substantially cylindrical about the axis of the can body 74. A knurling tool 76 is then used to superimpose the preselected pattern of mechanical deformations, in this case ribs and grooves, onto the intermediate can body, making it possible to produce a shaped can 20 of the type that is shown in Figure 2.

5                   In the third embodiment, shown in Figures 8 and 9, a spinning unit 68 is used to deform the cylindrical sidewall 12 of the can body blank 10 radially into the intermediate can body 74. Spinning unit 68 includes, as is well known in the technology, a mandrel 70 and a shaping roller 72 that is opposed to the mandrel 70. After this process, the knurling step shown in Figure 9 is preferably performed on the so formed intermediate  
10 can body 74 in a manner that is identical to that described above.

                  Alternatively to the knurling step shown in Figure 9, the intermediate can body 74 produced by either the method shown in Figure 7 or that shown in Figure 8 could, alternatively, be placed in a pneumatic expansion die or mold unit 40 of the type that is shown in Figures 3-5. Intermediate can body 74 would then be expanded in a manner that  
15 is identical to that described above in order to achieve the shaped can 20.

                  In the second and third methods described above, the can body blank 10 is also preferably partially annealed by the heat source 18 during the drying process, but, preferably, to a lesser extent than that in the first described embodiment. Preferably, the annealing for the second and third methods described above is performed at a temperature  
20 that is within the range of about 375 degrees Fahrenheit (about 190 degrees Celsius) to about 425 degrees Fahrenheit (about 218 degrees Celsius). The methods described with reference to Figures 7 and 8 thus require less annealing than that described with respect to the previous embodiment, meaning that a stronger shaped can 20 is possible at a given weight or wall thickness, or that the weight of the shaped can 20 can be reduced with  
25 respect to that produced by the first described method. Disadvantages of the second and third methods, however, include more machinery and greater mechanical complexity, as well as more wear and tear on the cans, spoilage and possible decoration damage as a result of the additional mechanical processing and handling.

                  It is to be understood, however, that even though numerous characteristics  
30 and advantages of the present invention have been set forth in the foregoing description, together with details of the structure and function of the invention, the disclosure is illustrative only, and changes may be made in detail, especially in matters of shape, size

and arrangement of parts within the principles of the invention to the full extent indicated by the broad general meaning of the terms in which the appended claims are expressed. Alternatively, for example, can body blank 10 could be formed by alternative processes, such as a draw-redraw process, a draw-thin-redraw process, or by a three-piece welded or  
5 cemented manufacturing process.

Throughout this specification and the claims which follow, unless the context requires otherwise, the word "comprise", and variations such as "comprises" and "comprising", will be understood to imply the inclusion of a stated integer or step or group of integers or steps  
10 but not the exclusion of any other integer or step or group of integers or steps.

2  
7  
R

8  
9  
E  
4

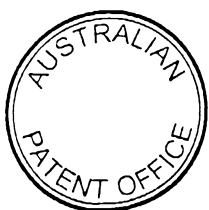

THE CLAIMS DEFINING THE INVENTION ARE AS FOLLOWS:

1. A method of reshaping a hollow can body blank that is used to make a can body, comprising:  
5 placing the can body blank into a chamber defined by a mold having three parts;  
supplying a pressurized fluid to the interior cavity of the hollow can body blank to expand the can body blank radially outwards onto the inner surface of the mold; and  
moving two of the mold parts towards the third from a first position in which the parts are spaced from each other by gaps which open into the mold chamber to a second position  
10 in which the gaps between the mold parts are reduced in size whilst still opening into the mold chamber.
2. A method according to claim 1, further comprising positioning the gaps at the points of maximum expansion of the can body blank.  
15
3. A method according to claim 1 or claim 2, further comprising applying a load to at least one end of the can body blank.
4. A method according to claim 3, comprising balancing the force exerted by the  
20 pressurized fluid on the interior of the can body blank and the load applied to the end or the ends of the can body blank.
5. A method according to claim 3, wherein said parts are moved together with a force that is sufficient to exert a net compressive force on the sidewall of the can body blank  
25 during shaping.
6. A method according to claim 1, wherein said parts are moved together with a force that is sufficient to balance forces in the sidewall of the can body blank during shaping.
- 30 7. An apparatus for reshaping a hollow can body blank comprising:  
a mold having three parts defining a chamber to accommodate the can body blank;  
means for supplying a pressurized fluid to the interior cavity of the hollow can body blank to expand the can body blank radially outwards onto the inner surface of the mold; and



means for moving two of the mold parts towards the third from a first position in which the parts are spaced from each other by gaps which open into the mold chamber to a second position in which the gaps between the mold parts are reduced in size whilst still opening into the mold chamber.

5

8. An apparatus according to claim 7, in which the gaps in the mold are position at the points of maximum expansion of the can body blank.

9. An apparatus according to claim 7 or claim 8, further comprising means for  
10 applying a load.

10. An apparatus according to claim 9, in which the means for applying a load comprises at least one piston.

11. An apparatus according to claim 10, in which the pistons are actuated by fluid  
15 pressure.

12. An apparatus according to claim 11, in which the pressurized fluid is supplied either independently or to any combination of the piston or pistons and can body blank cavity.  
20

13. An apparatus according to claim 12, in which a single pressurized fluid line supplies the piston or one of the pistons and the cavity and is split adjacent to or within the piston.

14. An apparatus according to any one of claims 7 to 13, in which contact of the  
25 expanded can body blank with the mold wall prevents further movement of the loading means whereby the loading means will not reach the limit of its movement before the can body blank is fully reshaped.

15. An apparatus according to claim 7, wherein said means for moving is  
30 constructed and arranged to move said parts together with a force that is sufficient to exert a net compressive force on the sidewall of the can body blank during shaping.



16. An apparatus according to claim 7, wherein said means for moving is constructed and arranged to move said parts together with a force that is sufficient to balance forces in the sidewall of the can body blank during shaping.

5 17. A method of reshaping a two piece can into a shape having two or more enlarged regions, the method comprising:

placing the can body blank into a chamber defined by a mold having three parts spaced from each other by gaps which open into the mold chamber and each of which is at, or substantially at, the position of maximum expansion of one of the enlarged regions;

10 supplying a pressurized fluid to the interior cavity of the hollow can body blank to expand the can body blank radially outwards onto the inner surface of the mold; and moving two of the mold parts towards the third as the can is being expanded.

15 18. A method according to claim 1 or 17 and substantially as hereinbefore described with reference to the accompanying drawings.

19. An apparatus according to claim 7 and substantially as hereinbefore described with reference to the accompanying drawings.

20 DATED this 16th day of February 2000

CROWN CORK & SEAL TECHNOLOGIES CORPORATION

By DAVIES COLLISON CAVE

25 Patent Attorneys for the Applicant

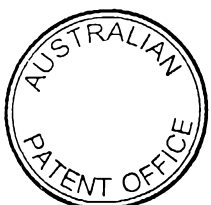

FIG. 1

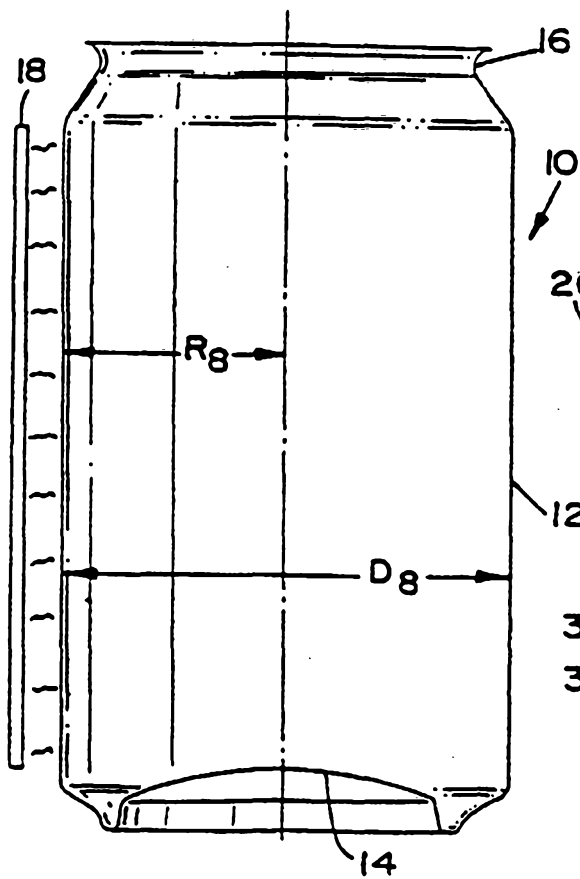

FIG. 2

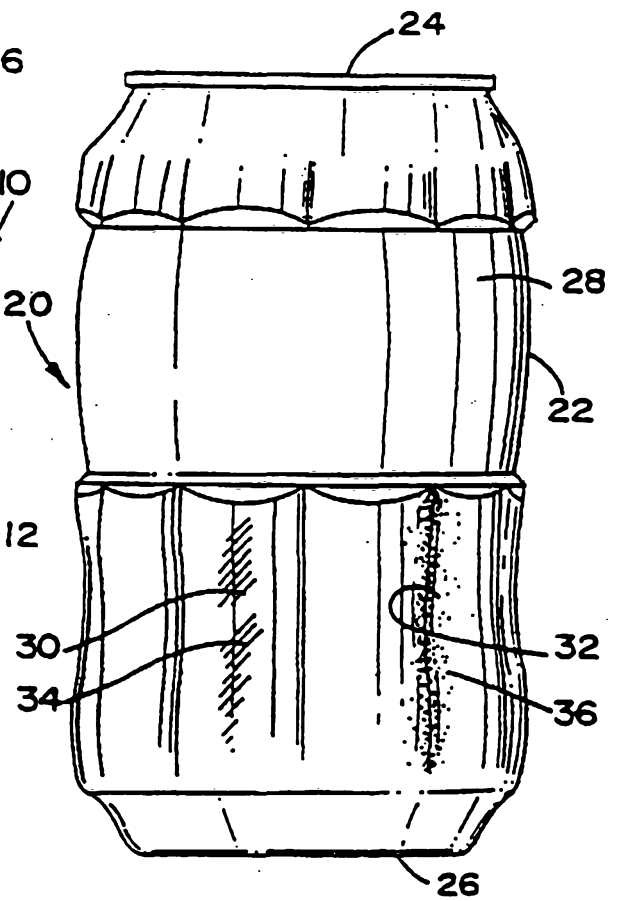

FIG. 3

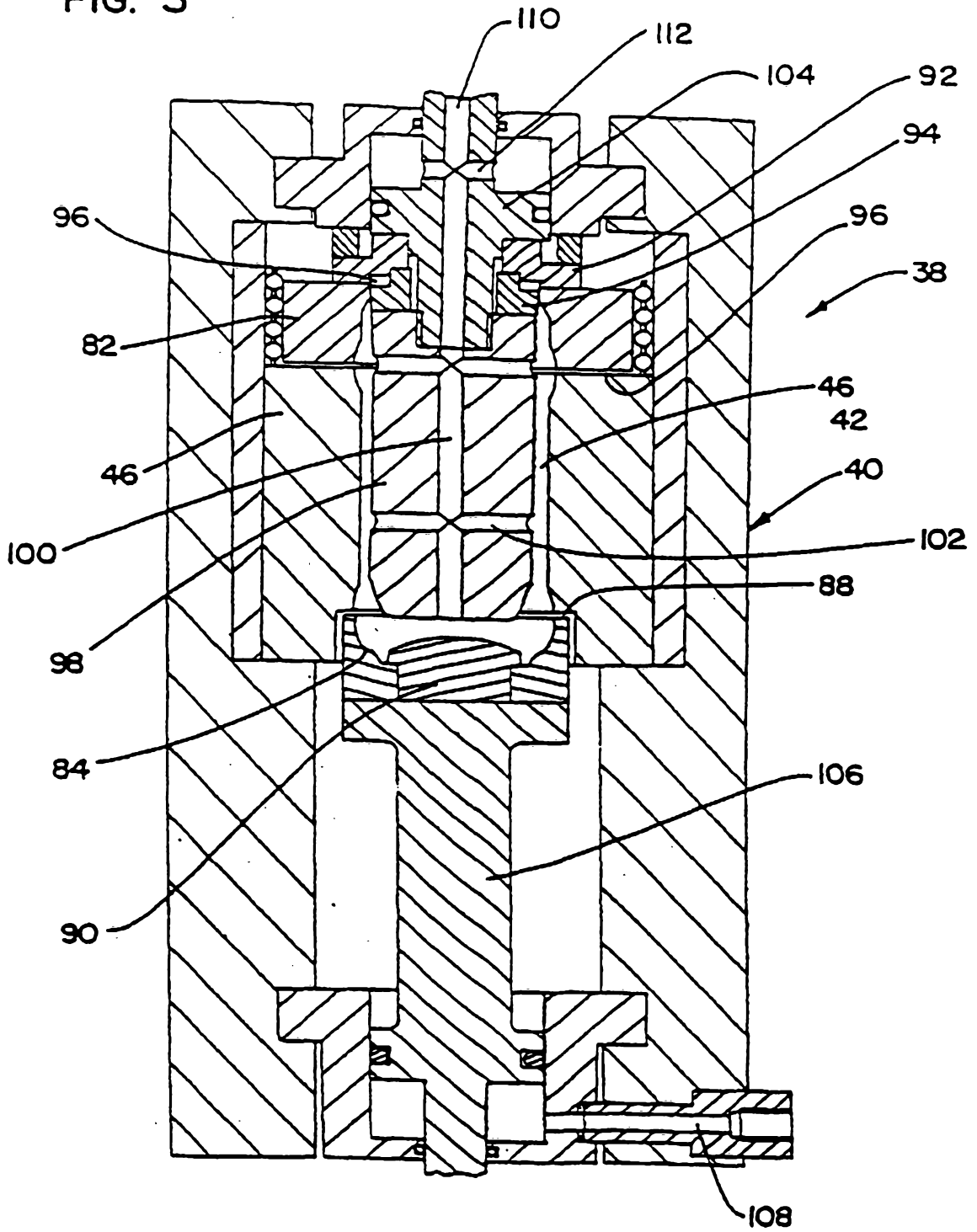

FIG. 4

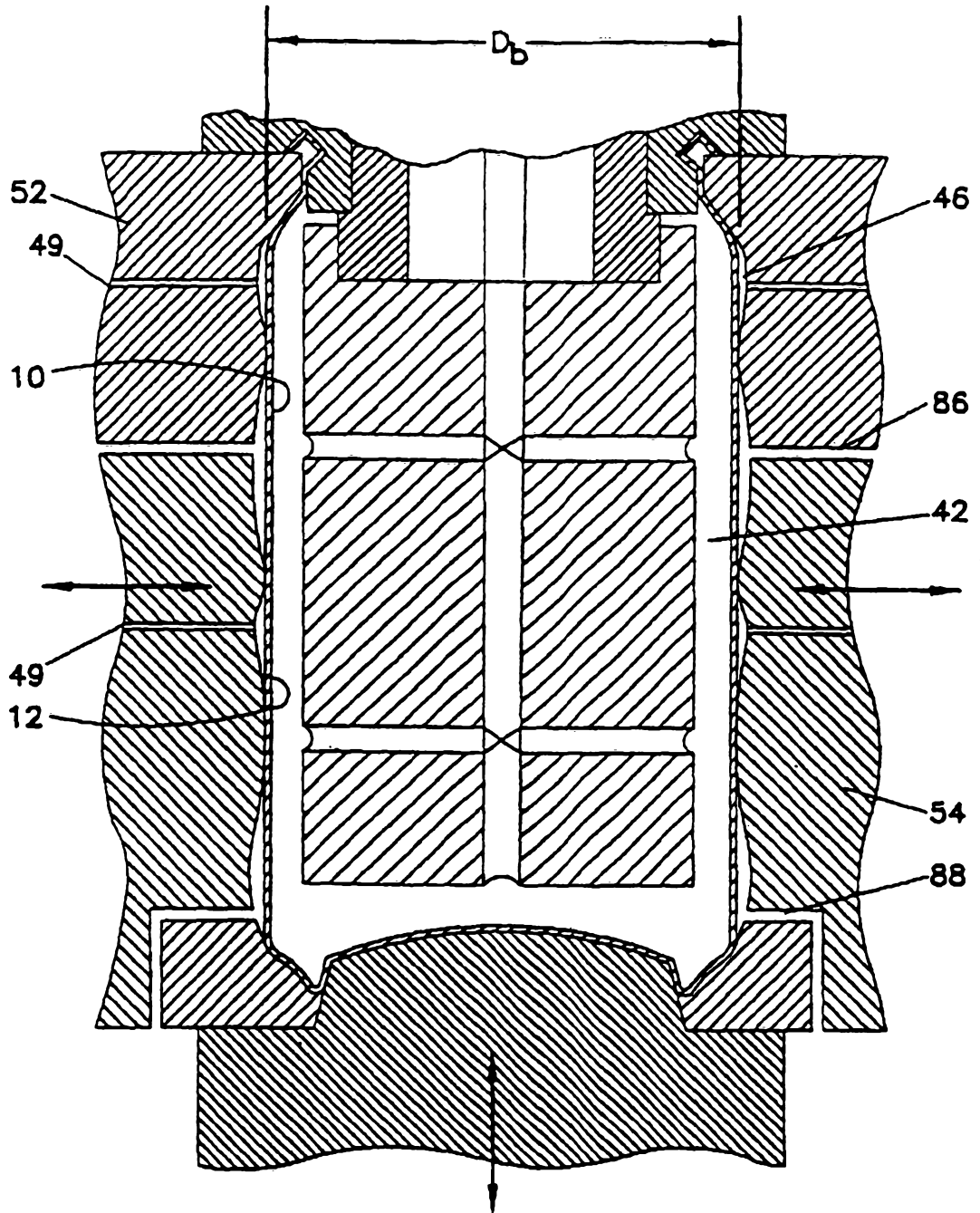
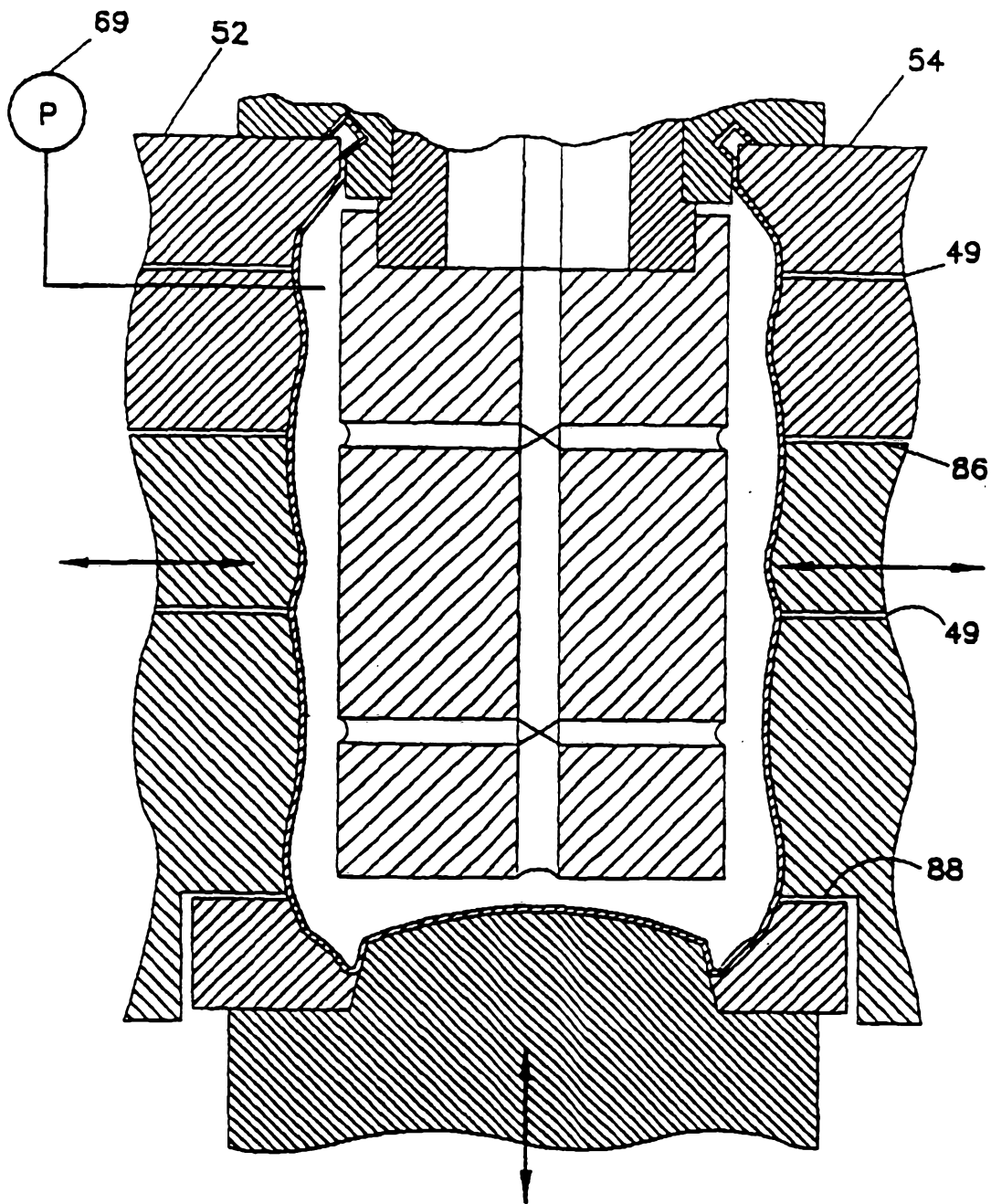

FIG. 5



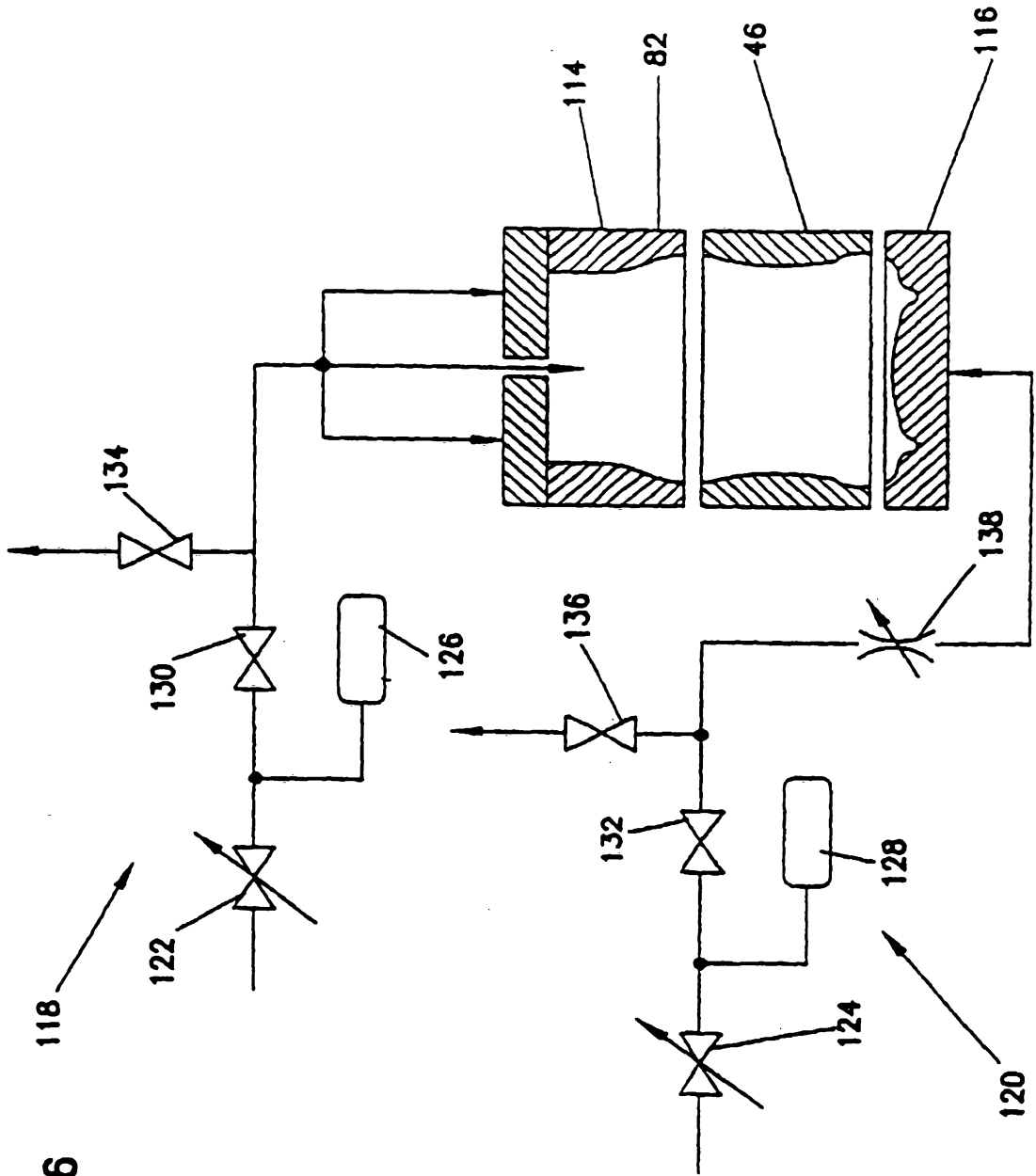

FIG. 6

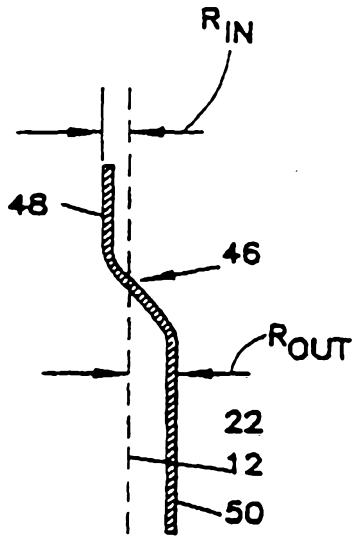

FIG. 7a

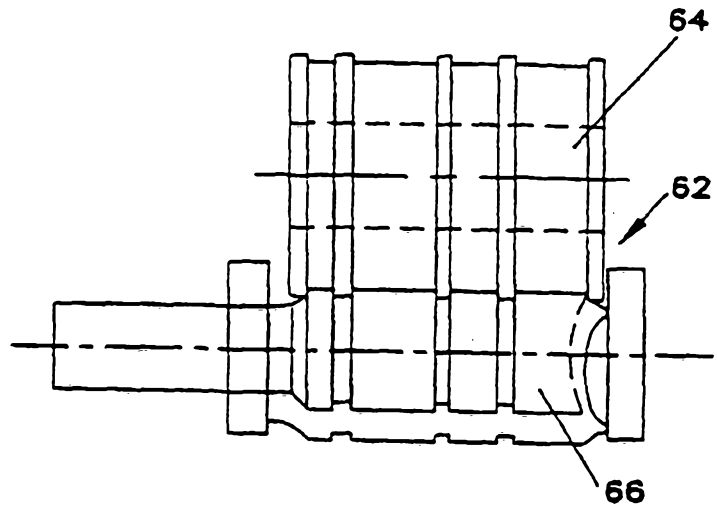

FIG. 8

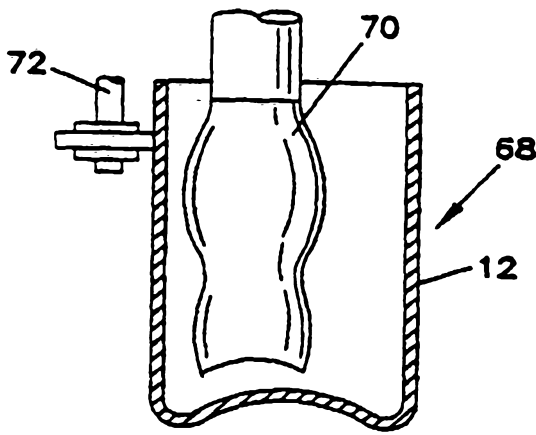

FIG. 9

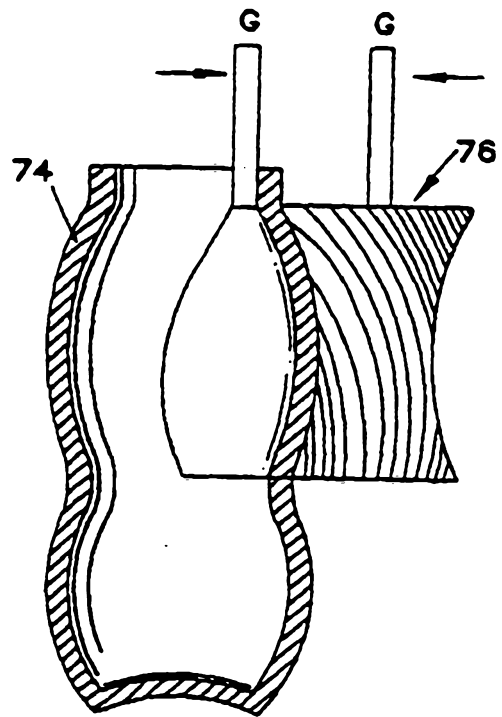

FIG. 10

FIG. 7b

