



- (51) International Patent Classification:
G01D 11/24 (2006.01) *G01D 21/02* (2006.01)
- (21) International Application Number:
PCT/US2016/052438
- (22) International Filing Date:
19 September 2016 (19.09.2016)
- (25) Filing Language: English
- (26) Publication Language: English
- (30) Priority Data:
14/871,884 30 September 2015 (30.09.2015) US
- (71) Applicant: ROSEMOUNT INC. [US/US]; 6021 Innovation Boulevard, Shakopee, MN 55379 (US).
- (72) Inventor: MCCOY, Steven, John; 19168 Poplar Circle, Eden Prairie, MN 55347 (US).
- (74) Agents: CHAMPLIN, Judson, K. et al.; Westman, Champlin & Koehler, P.A., 900 Second Avenue South, Suite 1400, Minneapolis, MN 55402-3319 (US).
- (81) Designated States (unless otherwise indicated, for every kind of national protection available): AE, AG, AL, AM, AO, AT, AU, AZ, BA, BB, BG, BH, BN, BR, BW, BY, BZ, CA, CH, CL, CN, CO, CR, CU, CZ, DE, DK, DM,

DO, DZ, EC, EE, EG, ES, FI, GB, GD, GE, GH, GM, GT, HN, HR, HU, ID, IL, IN, IR, IS, JP, KE, KG, KN, KP, KR, KW, KZ, LA, LC, LK, LR, LS, LU, LY, MA, MD, ME, MG, MK, MN, MW, MX, MY, MZ, NA, NG, NI, NO, NZ, OM, PA, PE, PG, PH, PL, PT, QA, RO, RS, RU, RW, SA, SC, SD, SE, SG, SK, SL, SM, ST, SV, SY, TH, TJ, TM, TN, TR, TT, TZ, UA, UG, US, UZ, VC, VN, ZA, ZM, ZW.

- (84) Designated States (unless otherwise indicated, for every kind of regional protection available): ARIPO (BW, GH, GM, KE, LR, LS, MW, MZ, NA, RW, SD, SL, ST, SZ, TZ, UG, ZM, ZW), Eurasian (AM, AZ, BY, KG, KZ, RU, TJ, TM), European (AL, AT, BE, BG, CH, CY, CZ, DE, DK, EE, ES, FI, FR, GB, GR, HR, HU, IE, IS, IT, LT, LU, LV, MC, MK, MT, NL, NO, PL, PT, RO, RS, SE, SI, SK, SM, TR), OAPI (BF, BJ, CF, CG, CI, CM, GA, GN, GQ, GW, KM, ML, MR, NE, SN, TD, TG).

Published:

- with international search report (Art. 21(3))
- before the expiration of the time limit for amending the claims and to be republished in the event of receipt of amendments (Rule 48.2(h))

(54) Title: PROCESS VARIABLE TRANSMITTER WITH TERMINAL BLOCK MOISTURE SENSOR

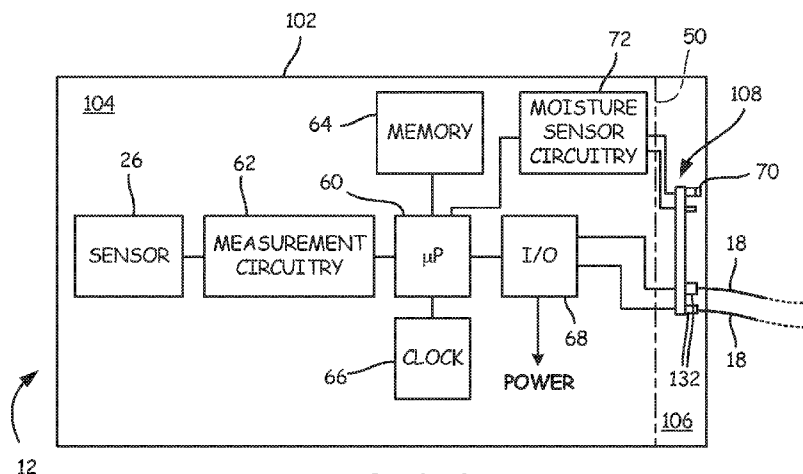

FIG. 2

(57) Abstract: A process variable transmitter (12) for use in an industrial process includes a housing (102) having a cavity formed therein. The housing has a barrier which divides the cavity into first (104) and second cavities. Measurement circuitry (62) in the first cavity (104) is configured to measure a process variable of the industrial process. A terminal block assembly (108) is located in the second cavity (106). A moisture sensor (70) has an electrical characteristic which changes based upon the presence of moisture in the second cavity (106).

WO 2017/058545 A1

PROCESS VARIABLE TRANSMITTER WITH TERMINAL BLOCK MOISTURE SENSOR

BACKGROUND

[0001] The present invention relates to industrial process control or monitoring systems. In particular, the present invention relates to process variable transmitters configured to sense process variables in such systems.

[0002] Process variable transmitters are used in industrial process control environments to monitor process variables. Such transmitters couple to a process fluid and provide measurements related to the process. Process variable transmitters can be configured to monitor one or more process variables associated with fluids in a process plant, such as slurries, liquids, vapors and gases in chemical, pulp, petroleum, gas, pharmaceutical, food and other fluid processing plants. Example monitored process variables include pressure, temperature, flow, level, pH, conductivity, turbidity, density, concentration, chemical composition or other properties of fluids. Typically, the process variable transmitters are located at remote locations, usually in a field, and send information to a centralized location such as a control room. Process variable transmitters sense process variables in a variety of applications, including oil and gas refineries, chemical storage tank farms, or chemical processing plants. In many instances, this requires the process variable transmitters to be located in a harsh environment.

[0003] Some types of process variable transmitters include a housing divided into two separate compartments. One compartment contains electrical circuitry and the other compartment contains a terminal block used to couple to a process control loop. One such configuration is shown in U.S. Patent No. 5,546,804. In such a configuration, the compartment which contains the terminal block may collect moisture due to condensation, leaks, or other sources. Such moisture may cause errors in data transmitted by the process variable transmitter and may even lead to ultimate failure of the device. One known technique to detect such moisture is by monitoring changes in electrical characteristics of the process control loop. Such techniques are shown and described in, for example, US Publication No. 2011/0010120, to Wehrs et al., entitled **PROCESS VARIABLE TRANSMITTER WITH TWO-WIRE PROCESS CONTROL LOOP DIAGNOSTICS** and assigned to Rosemount Inc.

SUMMARY

[0004] A process variable transmitter for use in an industrial process includes a housing having a cavity formed therein. The housing has a barrier which divides the cavity into first and second cavities. Measurement circuitry in the first cavity is configured to measure a process variable of the industrial process. A terminal block assembly is located in the second cavity. A moisture sensor has an electrical characteristic which changes based upon the presence of moisture in at least one of the first and second cavities.

[0005] This Summary and the Abstract are provided to introduce a selection of concepts in a simplified form that are further described below in the Detailed Description. The Summary and the Abstract are not intended to identify key features or essential features of the claimed subject matter, nor are they intended to be used as an aid in determining the scope of the claimed subject matter.

BRIEF DESCRIPTION OF THE DRAWINGS

[0006] FIG. 1 is a simplified diagram of an industrial process control system including a process variable transmitter configured to sense a process variable of the industrial process.

[0007] FIG. 2 is a simplified electrical block diagram of the process variable transmitter of FIG. 1.

[0008] FIG. 3A is a front plan view and FIG. 3B is a side cross-sectional view of one example configuration of a terminal block assembly used in the process variable transmitter of FIG. 1.

[0009] FIG. 4 is a simplified electrical schematic diagram of moisture sensor circuitry for use in sensing moisture proximate the terminal block assembly of FIGS. 3A and 3B.

[0010] FIGS. 5A and 5B are graphically representations of voltage versus time for the output of the moisture sensor circuitry of FIG. 4 when exposed to different amounts of moisture.

[0011] FIG. 6 is a perspective cross-sectional view of another configuration of the process variable transmitter of FIG. 1.

[0012] FIG. 7 is a rear perspective view of another example configuration of a terminal block assembly.

[0013] FIG. 8A is an exploded view and 8B is an assembled view of an electrical connector assembly used to electrically connect to the terminal block assembly illustrated in FIG. 7.

DETAILED DESCRIPTION OF ILLUSTRATIVE EMBODIMENTS

[0014] A process variable transmitter is provided having a housing with an internal cavity which is divided into first and second cavities. Measurement circuitry located in the first cavity is configured to measure process variable(s) and a terminal block is located in the second cavity. The terminal block is used to couple to external components such as a two-process control loop. A moisture sensor is provided in the second cavity and is configured to sense the presence of moisture in the second cavity. This information can be used to provide a diagnostic output such as a warning to an operator indicating a failure has occurred or that there is an impending failure. The diagnostic output can be sent over a process control loop or can be provided by some other output technique.

[0015] FIG. 1 is a simplified diagram of an industrial process control or monitoring system 10. System 10 includes a process variable transmitter 12 having a process variable sensor 26 arranged to sense a process variable of a process fluid. In this example, the process fluid is illustrated as contained in process piping 16. The process variable can be any property related to the process fluid such as flow rate, temperature, pressure, pH, etc. The process variable transmitter 12 couples to a two-wire process control loop 18 which carries a loop current I. In the example installation, the process variable transmitter is located at a remote location in the "field" of an industrial process and couples to a control room 20 at, for example, a centralized location through the two-wire process control loop 18. In this example, the control room 20 is illustrated as a sense resistor 22 and a voltage source 24. The transmitter 12 controls the loop current I such that the loop current is representative of the sensed process variable. For example, the loop current may range from 4 mA to 20 mA.

[0016] According to one embodiment, FIG. 2 is a simplified block diagram of process variable transmitter 12 having housing 102 with a cavity formed therein which is divided into a first (electronics) sealed cavity 104 and a second (terminal block) unsealed cavity 106 by barrier 50. A terminal block 108 is located in cavity 106. FIG. 2 illustrates the connection between terminal block 108 and two-wire process control loop 18. The two-wire process control loop 18 may be in accordance with industry standards and is used for transmitting information related to a sensed process variable by the process variable transmitter 12 as well as receiving power to power circuitry of the process variable transmitter 12. One such communication standard is a 4-20 mA communication standard in which an analog current level is used to represent a process variable. A digital signal may also be modulated onto the analog current level to transmit additional information

in accordance with the HART® Protocol. The two wire process control loop can also be used for sending information to the process variable transmitter 12. Other types of process control loops may also be used including those in accordance with a Fieldbus standard. Further, the process control loop 18 may be a wireless process control loop in which information is communicated wirelessly. One such wireless communication protocol is the WirelessHART® communication protocol in accordance with IEC 62591. The terminal block 108 is not limited to these types of connections and may include other types of electrical connections or components. Examples include a MODBUS® serial protocol connection or other types of connections for providing power and communications, in both analog and digital formats.

[0017] As illustrated in FIG. 2, the first enclosure 104 includes a microprocessor 60 coupled to the process variable sensor 26 through measurement circuitry 62. Microprocessor 60 operates in accordance with instructions stored in memory 64 which may also be used to store other information such as configuration information. Microprocessor 60 operates based upon a clock rate determined by clock 66 and communicates over the process control loop 18 using I/O circuitry 68 through terminal block 108 using connection terminals 132. I/O circuitry 68 may optionally include a power output used to power circuitry of the process variable transmitter 12. In one such configuration, power from the two-wire process control loop 18 is used to wholly power the device.

[0018] FIG. 2 also illustrated a moisture sensor 70 carried in the second enclosure 106. In the configuration illustrated in FIG. 2, the moisture sensor is carried on the terminal block 108. However, other configurations may also be employed. Moisture sensor 70 couples to moisture sensor circuitry 72 which is configured to provide an output to microprocessor 60. In operation, the moisture sensor 70 senses moisture and provides an electrical output to the moisture sensor circuitry 72. Moisture sensor circuitry may compare the output to, for example, a threshold level and responsively provide an output to microprocessor 60 providing an indication of the presence of moisture. Similarly, such a determination may also be performed by the microprocessor 60. The moisture sensor 70 may be in accordance with any appropriate technologies and a number of technologies are discussed below.

[0019] Typically, moisture accumulates near the terminal block assembly 108 at a relative slow rate such that the level of the moisture rises over time until it eventually contacts the electrical components and terminals of the terminal block 108. This causes a low impedance path (typically less than 10k ohms) between the terminals 132 and/or the housing 102. On the other hand, a dry

terminal block 108 will typically have a leakage resistance of more than 100M ohms. In one configuration, the moisture sensor 70 is positioned such that any moisture in the second compartment 106 will reach the moisture sensor 70 before it contacts terminals 132 of the terminal block assembly 108. This allows the transmitter 12 to provide a warning output indicating an impending failure. A second moisture sensor can be employed to provide an indication that additional water or other moisture has accumulated. This can be used to provide an output that a failure is imminent. This allows warnings to be sent in the form of an alarm signal before the loop 18 is compromised at which point it may be unable to reliably transmit an alarm signal. The sensor can be automatically checked on a periodic basis, or continually checked for moisture. The moisture sensor 70 can be configured as desired. For example, a single ended configuration may be employed in which a return path of any leakage current through the moisture impedance is provided through the chassis (housing) of the device. A dual ended configuration may also be employed in which two connections are made to the sensor 70 for providing a separate return path.

[0020] According to one embodiment, FIG. 3A is a front plan view and FIG. 3B is a side cross-sectional view of the terminal block assembly 108. As illustrated in FIG. 3A, the moisture sensor 70 is positioned around an outer edge of the terminal block assembly 108. In the configuration of FIG. 3A, the terminal block assembly is disc shaped and configured to fit within a cylindrical housing 102. The location of the sensors 70 should be chosen as appropriate to obtain warnings based on the presence of moisture at the desired locations to be monitored. In the examples of 3A and 3B, the sensors 70 are positioned around the outer edge of the assembly 108 and configured to surround the terminals 132. Depending on the installation configuration, the transmitter 12 may be rotated 90 degrees. As illustrated in FIG. 3A, four different sensors 70 are positioned at 90 degrees around the outer circumference of the assembly 108. In the example configuration of FIG. 3B, sensor 70 includes a longer warning sensor 70A and a shorter alarm sensor 70B. Sensor 70A is configured to contact a small amount of accumulated moisture and thereby provide an early warning that moisture is building up within the second cavity 106. Sensor 70A is positioned such that it senses moisture just prior to the moisture contacting terminals 132. Sensors 70A and 70B can comprise elongate electrodes or the like. Although the sensors 70A, B are shown as spaced apart individual components, in one configuration the electrodes are configured to span an outer circumference of the terminal block 108. For example, the electrodes may complete a circle around the outer circumference of the terminal block assembly 108.

[0021] The moisture sensor electrodes 70A and 70B couple to moisture sensor circuitry 72 shown in FIG. 2. The moisture sensor circuitry may operate in accordance with any appropriate technique to detect impedance changes due to the presence of moisture.

[0022] The impedance measurement can preferably be made with a number of assumptions. It may be assumed that the chassis ground can be at +/- 600 VDC or at a +/- 600 VDC potential. Further, 50 or 60 Hz noise may be present between the circuitry and the chassis ground. Any appropriate measurement technique may be implemented as desired. FIG. 4 shows one example configuration of moisture sensor circuitry 72. Moisture sensor circuitry 72 operates with a single moisture sensor and a second electrical circuit should be used for two sensors such as 70A, B. In the circuit of FIG. 4, field effect transistors M1, M2 and M3 can be configured to operate under the control of microprocessor 60 shown in FIG. 2. Initially, transistors M1 and M2 are off and transistor M3 is on. This causes an electrical short of the storage capacitors C4 to thereby dissipate any charge. Next, transistors M3 and M2 are turned off and transistor M1 is turned on. This causes transistor C2 to charge through the impedance due to any moisture in contact with the electrodes of the moisture sensor 70 through the return path 102 and capacitor C1. If moisture is present, a larger charge accumulated on C2 whereas a dry system will only accumulate a small charge. Transistors M3 and M1 are then turned off and transistor M2 is turned on. This causes the charge from capacitor C2 to be transferred to C4 through resistance R7. Transistors M3 and M2 are then turned off and transistor M1 is turned back on thereby charging capacitor C2 again. When M1 is on, the comparator input is high and the comparator output drives low. When M2 is on, the comparator input is pulled below the threshold V_t until C4 accumulates enough charge. The comparator output will continue to toggle high and low until the comparator input remains above V_t . Charge is accumulated on C4 due to repeating the M1, M2 sequence. This process repeats and the voltage applied to comparator U1 increases with each cycle. When this voltage is greater than a reference voltage V_T , the output from comparator U1 remains low. The comparator signal is driven high when M1 turns on. This causes the To_Counter signal to go low. When M1 turns off, and M1 turns on, the comparator signal will initially be driven to a near ground potential. This causes the To_Counter signal to toggle high. As C4 continues to charge (due to repeating the M1, M2 sequence), the voltage on the comparator will transition at the voltage threshold (about 1.25 volts) thereby toggling the To_Counter signal. By counting the toggles of the To_Counter output, the number of charging cycles will indicate the amount of moisture present. A large number of toggles will indicate a low leakage or dry condition

and a small number of toggles (cycles) represents a high leakage or wet condition. The threshold count may be adjusted by experimentation to delineate between the selected wet and dry circuit conditions. These steps can be repeated as desired to detect moisture. For example, once per minute, and may be performed along with other background tasks by the microprocessor 60.

[0023] FIG. 5A is an example output from comparator U1 when an impedance of 10M ohms is coupled to circuitry 72. The circuit does not trip until about 125 milliseconds indicating a “dry” condition. In the graph of 5B, the circuit trips at less than 20 milliseconds. This indicates a “wet” condition. The particularly timing threshold can be determined based upon testing or by some other means.

[0024] Capacitors C1 and C2 provide a charging path as well as isolate internal measurement circuits from DC voltages that may be present on the chassis of the device. This isolation eliminates potential circuit damage or errors in measurements. Resistor R7 can be used to measure circuit damage due to electrostatic discharge (ESD) or other transient sources. A return path 102 through the chassis ground or other return electronics through capacitor C1 is shown. For metal housings, the moisture will short between the chassis of the device and the sensor and the conduction path will include the device housing. However, for non-conductive configurations, for example with a plastic housing, a second electrode may be included to provide a capacitively coupled path for the charging cycle.

[0025] Once a moisture warning or alarm condition is detected, the microprocessor 70 can provide a warning output, for example by setting a warning current level on the process control loop 18 or by providing status information using a digital protocol such as HART Communications.

[0026] FIG. 6 is a partial cross-sectional view of process variable transmitter 12 including another example configuration of the terminal block assembly 108. Terminal block assembly 108 includes terminal block shroud 130 which carries connectors 132 thereon. Shroud 130 mounts into a recess formed in barrier 50. Barrier 50 also carries an electrical connector assembly 150. Moisture sensors 70 are positioned at desired locations on the housing 130 of the terminal block assembly 108 and are electrically connected to electrical conductors of the electrical connector assembly 150. As illustrated, the electrical connector assembly 150 extends through the barrier 50 and provides electrical connections between the first cavity 104 and the second cavity 106. Further, in this example configuration, the terminal block assembly 108 includes an internal cavity 152 which is arranged to provide a third cavity within the housing 102 of transmitter 12. FIG. 7 is a rear

perspective view of the terminal block assembly 108. A circuit board 138 within the shroud 130 carries a female electrical connector 164 for electrically connecting to the electrical connector assembly 150. FIG. 8A is an exploded perspective view and FIG. 8B is a perspective view of the electrical connector assembly 150. Connector assembly 150 is formed in two halves 160A, 160B with electrical conductor pins 162 carried therein. Conductor pins 162 are held in place by supports 164. Tab stops 165 are arranged to secure the electrical connector assembly 150 in position in the barrier 50.

[0027] Pursuant to an embodiment, The moisture sensing system for wet terminal block detection discussed herein operates by measuring the impedance between two points. The sensor 70 can be fabricated from two circuit board traces separated by a space. As the humidity level changes, the impedance will change. In a typical application, the warning point should be well defined and set such that water (condensing) across the sensor causes the alert. Normal high humidity should preferably not cause a warning to occur. In one configuration the sensor 70 provides a single connection point which is electrically connected to the moisture sensor circuitry 72 through the barrier 50. A return path for the electrical signal may be provided through the housing 102 in configurations where the transmitter housing 102 is formed of a metal or other conductor. Multiple sensors can be provided using any number of the conductor pins 162 of the electrical connector assembly 150.

[0028] Although the present invention has been described with reference to preferred embodiments, workers skilled in the art will recognize that changes may be made in form and detail without departing from the spirit and scope of the invention. The term “moisture” as used herein includes any liquid or gas which is conductive in nature and capable of electrically shorting electrical components. Although a two-wire process control loop 18 is specifically illustrated herein, the configurations are well suited for other communication techniques including a wireless technique. In such a configuration I/O circuitry 68 is configured for wireless communication. The moisture sensors may be carried on the terminal block assembly, mounted on an interior wall of the housing 102, or positioned at some other location within the second cavity 106 as well as positioned in the first cavity 104, or elsewhere within the device. For example, if the cover is not sufficiently tightened on the first cavity 104, moisture may enter the first cavity. The circuitry set forth herein may be used to detect such moisture. Although a passive sensor configuration is illustrated for sensor 70, sensor 70 may also employ active components. Additionally, the moisture sensor circuitry 72

may be carried within the second cavity 106, for example on the terminal block assembly 108. The impedance measurement may be made between a single electrical contact and electrical ground such as that provided by housing 102, or may be made between two individual electrical contacts. The moisture sensor may be positioned or otherwise calibrated to sense different levels of moisture and thereby provide an early warning a final alert. Further, although only two fixed levels of alerts are specifically discussed, a continuous output may also be provided as well as any number of discrete outputs indicating an amount of moisture which is present related to the amount of moisture present in the cavity 106. In one configuration, the moisture sensor is positioned proximate a screw carried on the terminal block which is used for connecting the terminal block to a conductor. In one aspect, a moisture detection circuit is provided which does not disturb other transmitter electronics due to interference from outside sources. Such interference may be due to DC offset voltages or low frequency noise, such as 50 or 60Hz noise. The isolation is provided to block this interference. In one specific configuration, capacitors are used to provide this isolation.

WHAT IS CLAIMED IS:

1. A process variable transmitter for use in an industrial process, comprising:
 - a housing having a cavity formed therein, the housing including a barrier which divides the cavity into first and second cavities;
 - measurement circuitry in the first cavity configured to measure a process variable of the industrial process; and
 - a terminal block assembly in the second cavity;
 - a moisture sensor configured to sense the presence of moisture in at least one of the first and second cavities and having an electrical characteristic which varies based upon moisture in the at least one of the first and second cavities.
2. The process variable transmitter of claim 1 wherein the moisture sensor is positioned in the first cavity.
3. The process variable transmitter of claim 1 wherein the moisture sensor is positioned in the second cavity.
4. The process variable transmitter of claim 1 wherein the moisture sensor is mounted on the terminal block in the second cavity.
5. The process variable transmitter of claim 1 wherein the moisture sensor is configured to measure an impedance between a conductor and a return path.
6. The process variable transmitter of claim 5 wherein the return path comprises the housing.
7. The process variable transmitter of claim 1 wherein the moisture sensor comprises first and second electrical conductors having an impedance formed therebetween which changes based upon a presence of moisture.
8. The process variable transmitter of claim 1 including electrical circuitry configured to monitor the electrical characteristic of the moisture sensor.
9. The process variable transmitter of claim 8 wherein the electrical characteristic comprises impedance.
10. The process variable transmitter of claim 8 wherein the electrical circuitry provides a toggled output.
11. The process variable transmitter of claim 10 wherein a number of toggles is related to an amount of moisture present in the at least one of the first and second cavities.

12. The process variable transmitter of claim 10 including a microprocessor configured to detect moisture based upon the toggled output.
13. The process variable transmitter of claim 1 including electrical circuitry configured to compare the electrical characteristic of the moisture sensor with a threshold.
14. The process variable transmitter of claim 1 including a plurality of moisture sensors.
15. The process variable transmitter of claim 14 wherein the plurality of moisture sensors are positioned at an angular offset with respect to one another.
16. The process variable transmitter of claim 15 wherein the angular offset comprises 90 degrees.
17. The process variable transmitter of claim 1 including electrical conductors which extend through the barrier of the housing to the moisture sensor.
18. The process variable transmitter of claim 1 including an output circuitry configured to provide a warning output.
19. The process variable transmitter of claim 18 wherein the warning output is provided on a two wire process control loop.
20. The process variable transmitter of claim 1 wherein the terminal block is configured to couple to a two wire process control loop.
21. The process variable transmitter of claim 18 wherein the warning output is indicative of an impending failure due to detected moisture.
22. The process variable transmitter of claim 1 wherein the moisture sensor is configured to sense a presence of moisture at a first position and further including a second moisture sensor configured to sense a presence of moisture at a second position.
23. The process variable transmitter of claim 1 wherein the moisture sensor comprises an electrical trace carried on a circuit board.
24. The process variable transmitter of claim 1 wherein the moisture sensor is positioned proximate a screw on the terminal block assembly.
25. The process variable transmitter of claim 1 including isolation circuitry to isolate the measurement circuitry from the interference received through the moisture sensor.
26. The process variable transmitter of claim 25 wherein the isolation circuitry comprises a capacitor.

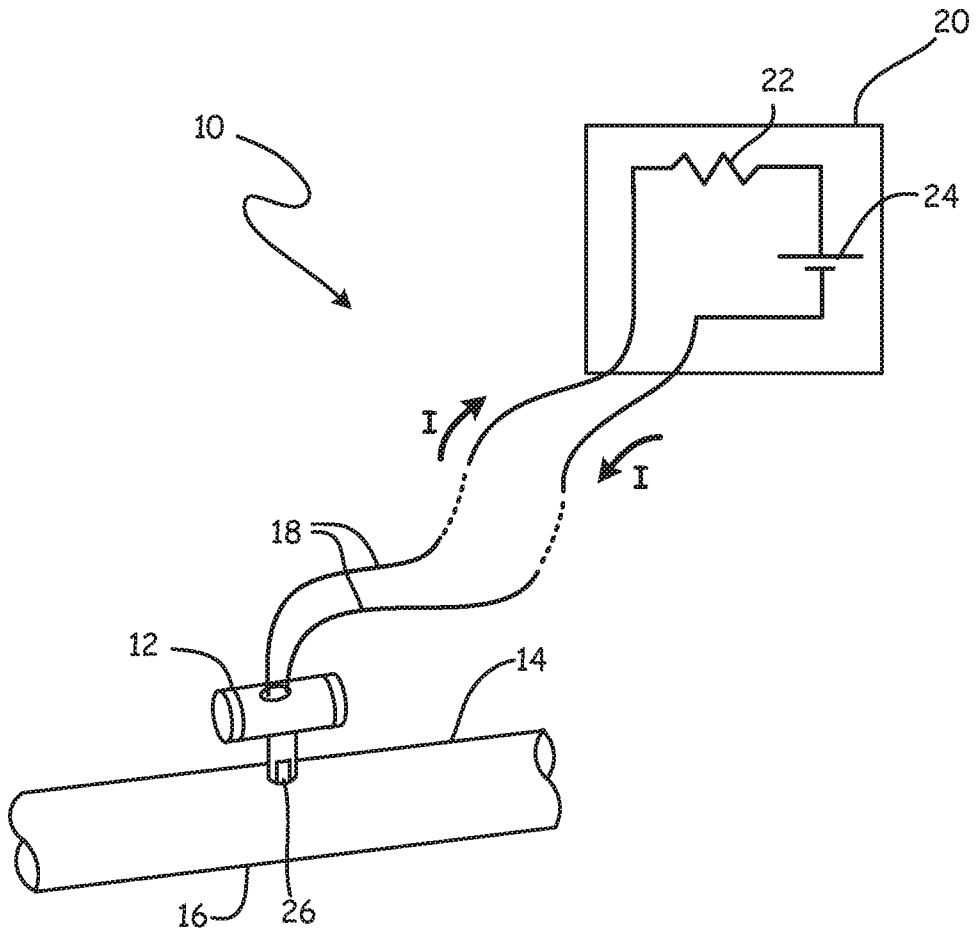

FIG. 1

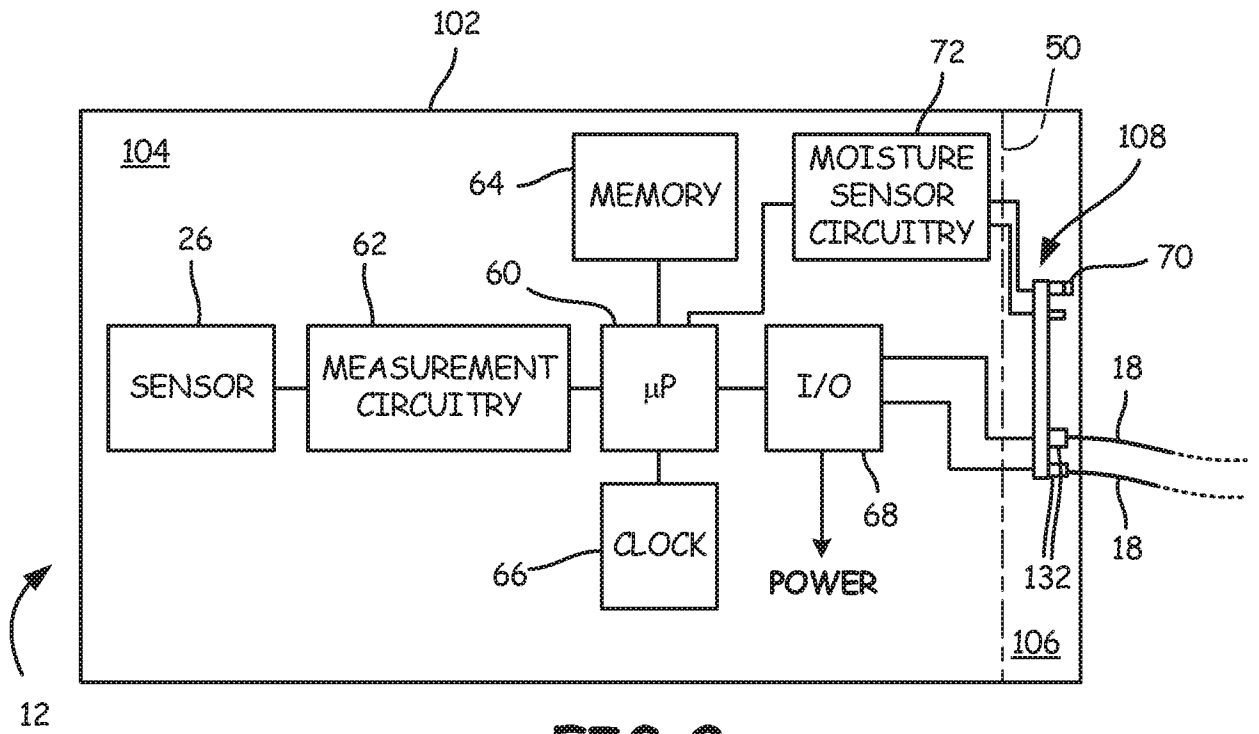
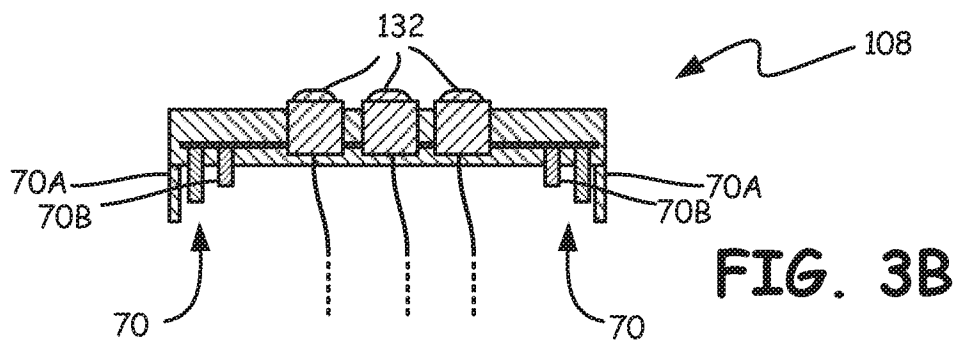
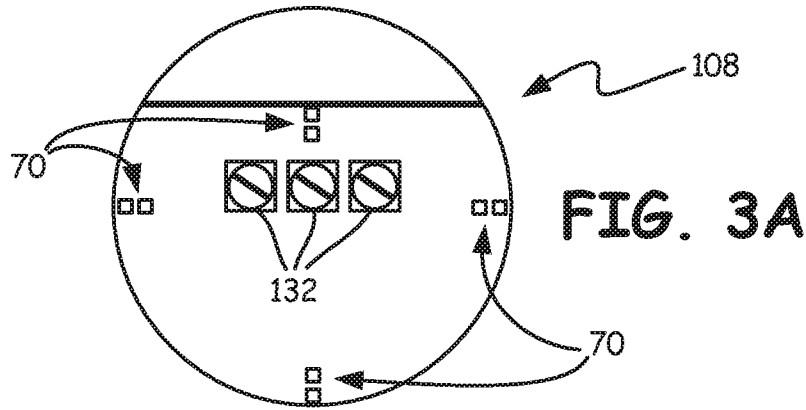

FIG. 2



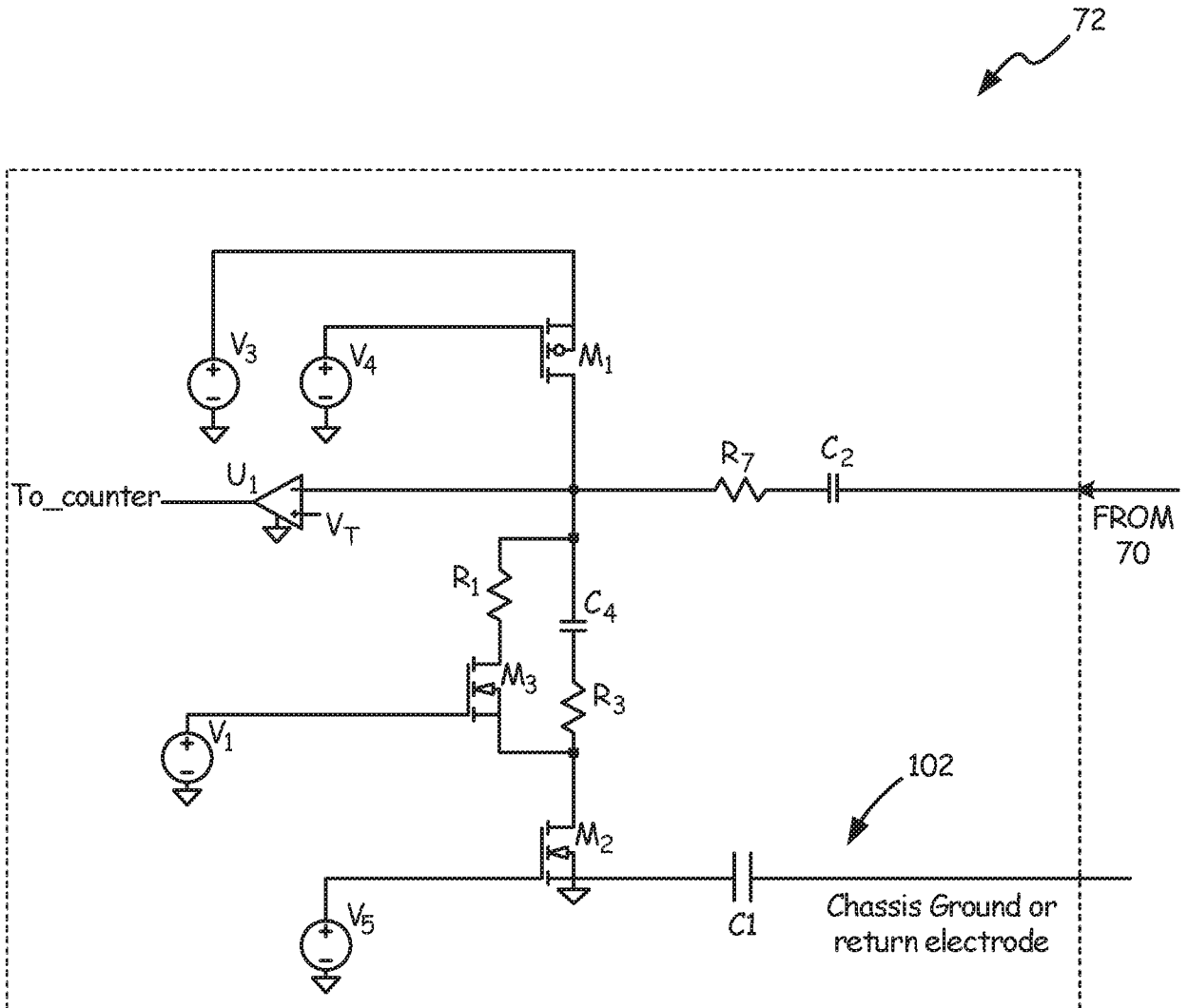
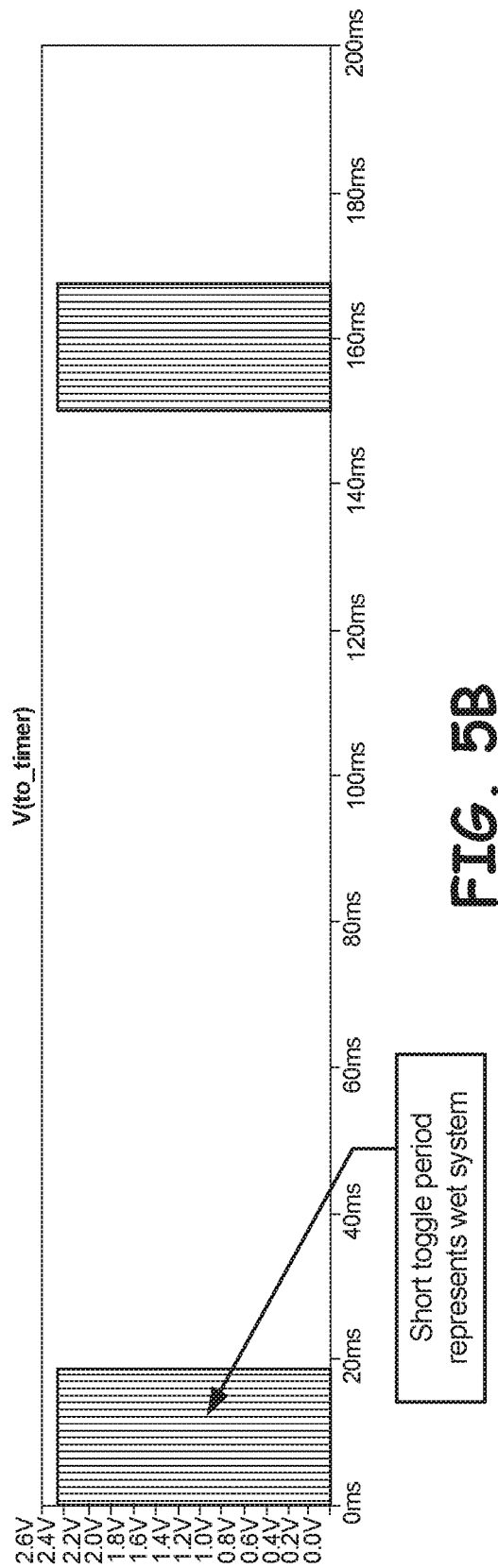
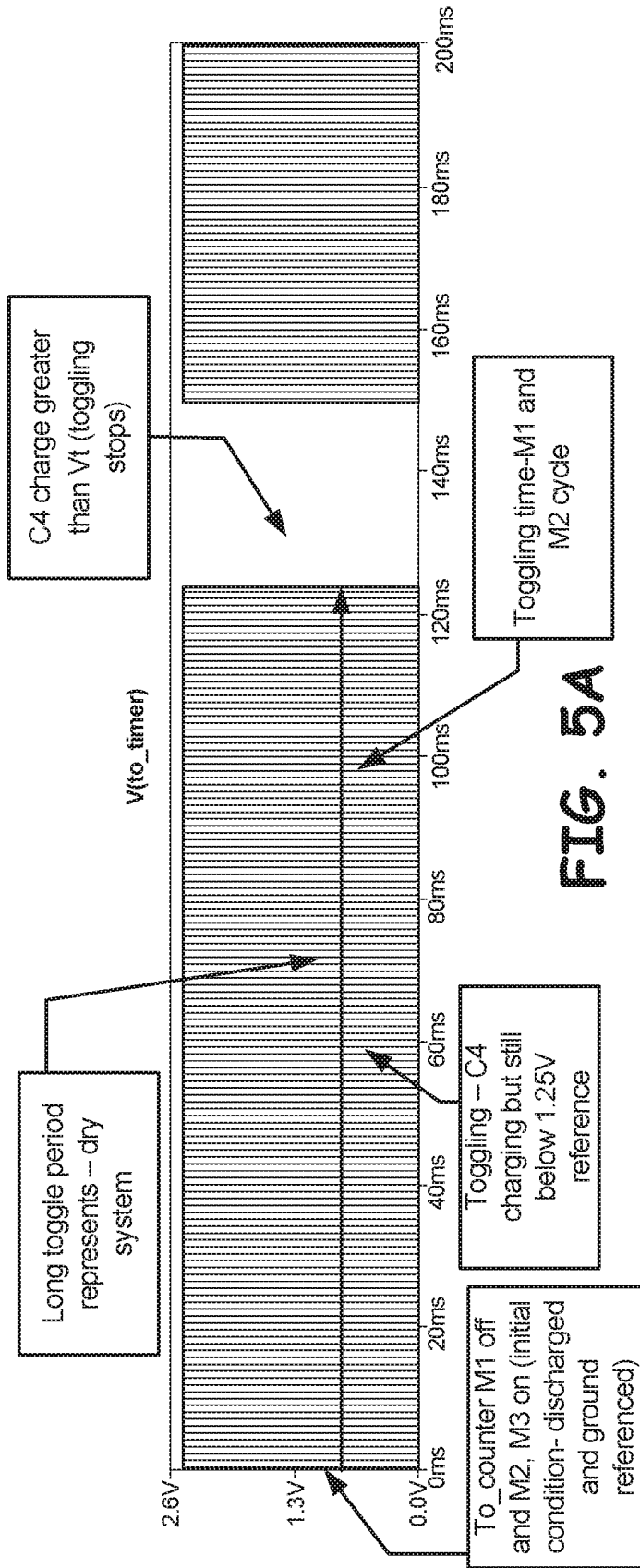

FIG. 4



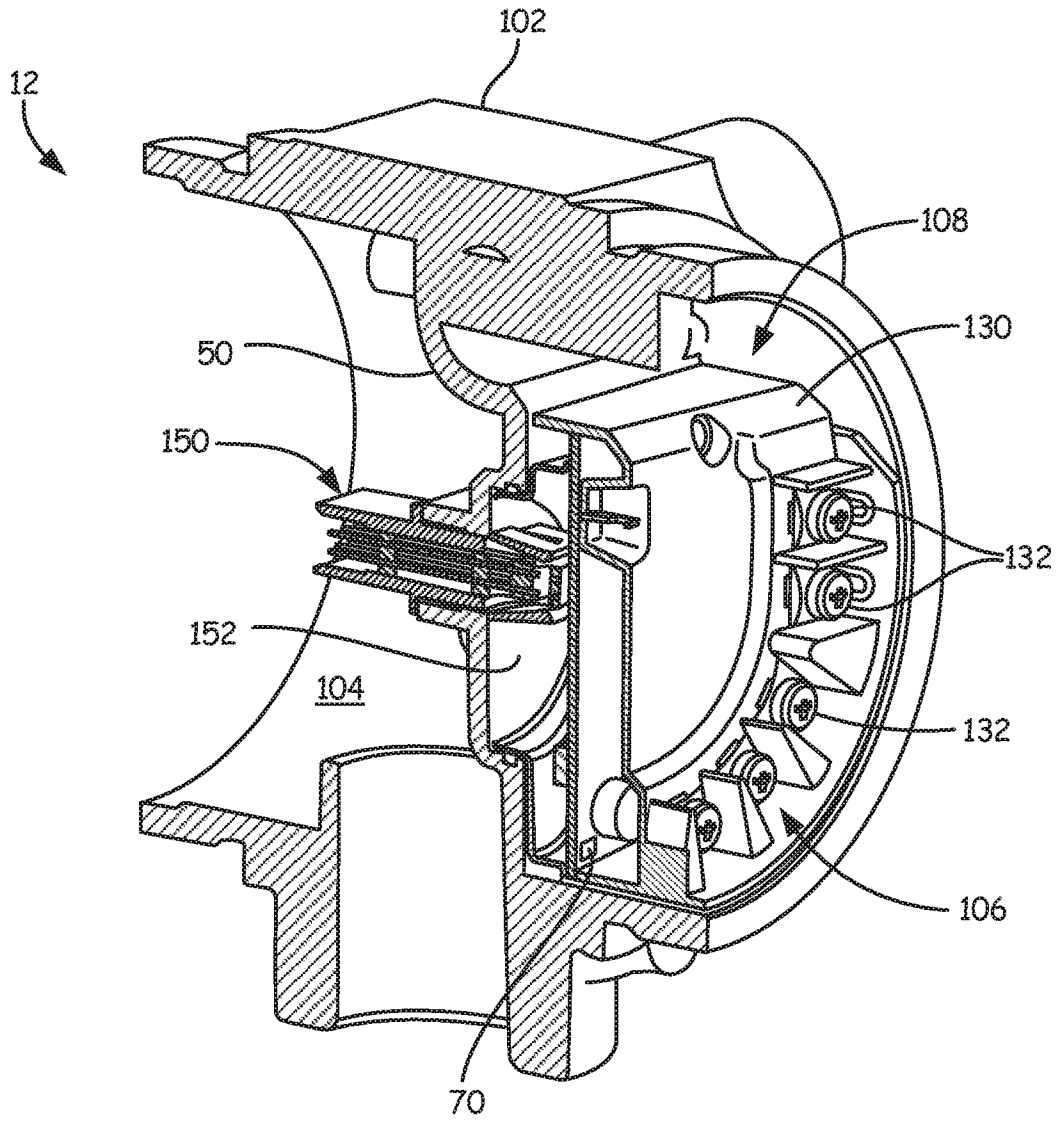

FIG. 6

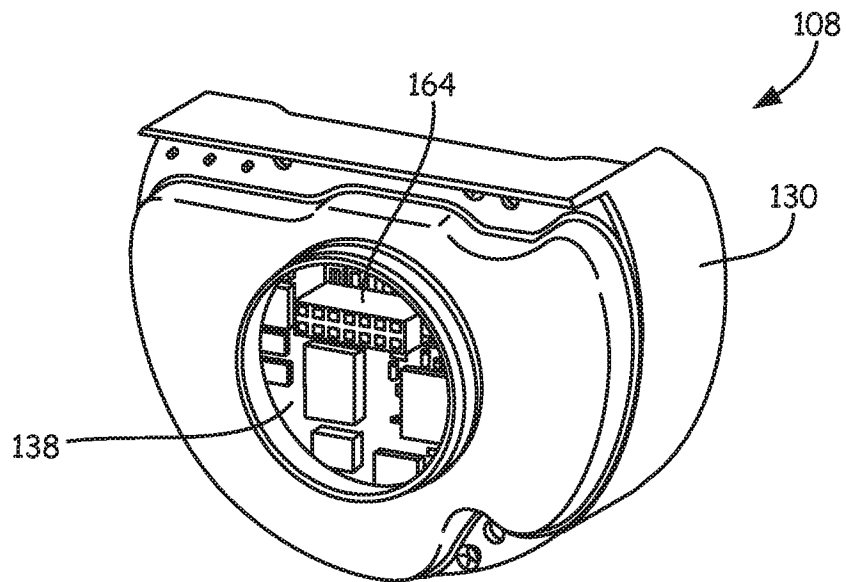

FIG. 7

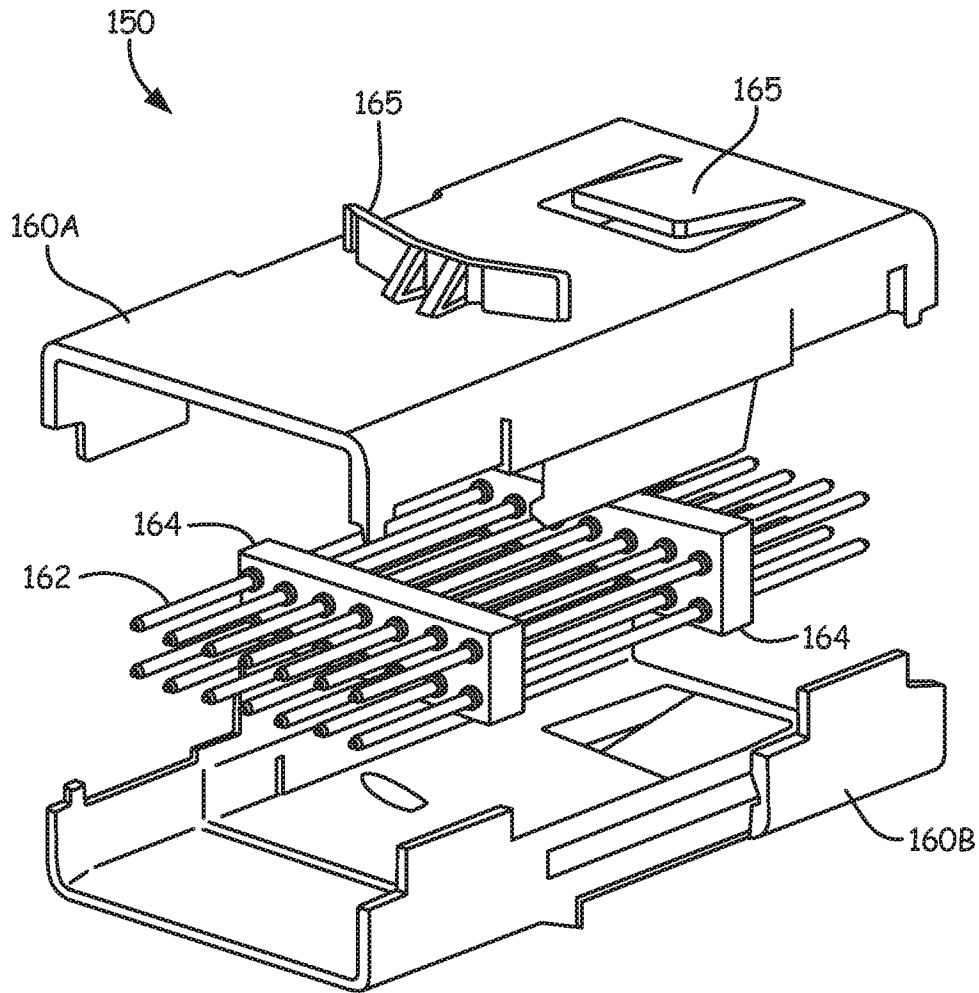

FIG. 8A

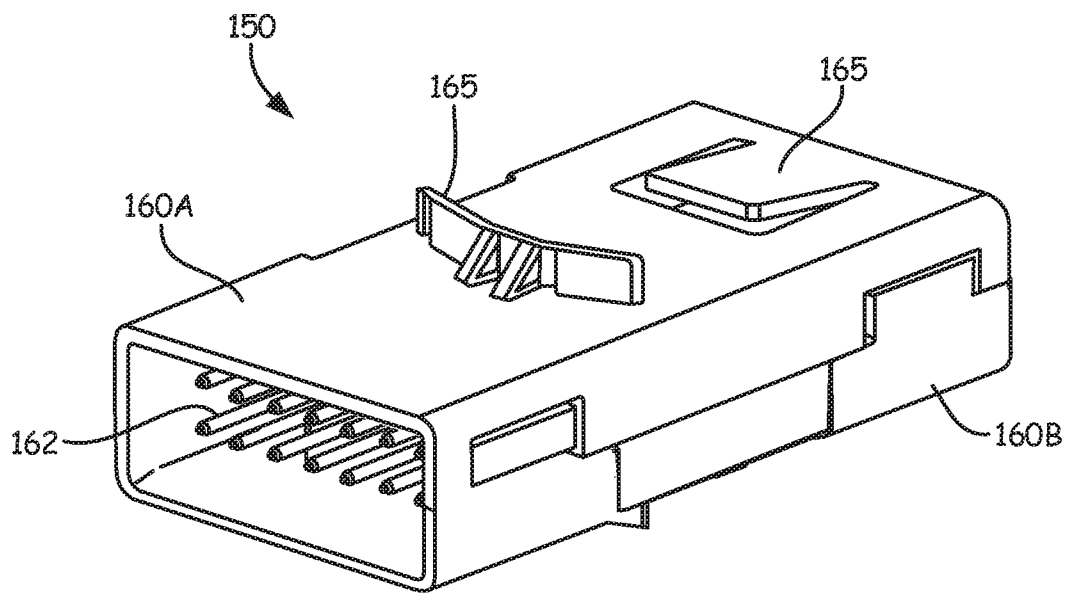

FIG. 8B

INTERNATIONAL SEARCH REPORT

International application No
PCT/US2016/052438

A. CLASSIFICATION OF SUBJECT MATTER
INV. G01D11/24 G01D21/02
ADD.
According to International Patent Classification (IPC) or to both national classification and IPC

B. FIELDS SEARCHED
Minimum documentation searched (classification system followed by classification symbols)
G01D
Documentation searched other than minimum documentation to the extent that such documents are included in the fields searched

Electronic data base consulted during the international search (name of data base and, where practicable, search terms used)
EPO-Internal, WPI Data

C. DOCUMENTS CONSIDERED TO BE RELEVANT

Category*	Citation of document, with indication, where appropriate, of the relevant passages	Relevant to claim No.
X	US 6 701 274 B1 (ERYUREK EVREN [US] ET AL) 2 March 2004 (2004-03-02)	1-4,8, 13,17, 23,24
Y	Abstract, Desc. col. 6 / l. 34-67, p. 8 / l. 37-45, Fig. 5	9-12, 14-16,22
X	DE 10 2011 088302 A1 (ENDRESS & HAUSER GMBH & CO KG [DE]) 13 June 2013 (2013-06-13)	1-4,8, 17,23,24
Y	Abstract, Desc. [0021], [0025], [0028], Fig. 1	9-12, 14-16,22
X	WO 2014/203553 A1 (HITACHI AUTOMOTIVE SYSTEMS LTD [JP]) 24 December 2014 (2014-12-24)	1-4,8, 17,23,24
Y	Abstract, Desc. p. 6 / l. 25-35, p. 7 / l. 11-18, Fig. 2, 3	9-12, 14-16,22
	----- -/--	

Further documents are listed in the continuation of Box C.

See patent family annex.

* Special categories of cited documents :

- "A" document defining the general state of the art which is not considered to be of particular relevance
- "E" earlier application or patent but published on or after the international filing date
- "L" document which may throw doubts on priority claim(s) or which is cited to establish the publication date of another citation or other special reason (as specified)
- "O" document referring to an oral disclosure, use, exhibition or other means
- "P" document published prior to the international filing date but later than the priority date claimed

- "T" later document published after the international filing date or priority date and not in conflict with the application but cited to understand the principle or theory underlying the invention
- "X" document of particular relevance; the claimed invention cannot be considered novel or cannot be considered to involve an inventive step when the document is taken alone
- "Y" document of particular relevance; the claimed invention cannot be considered to involve an inventive step when the document is combined with one or more other such documents, such combination being obvious to a person skilled in the art
- "&" document member of the same patent family

Date of the actual completion of the international search

17 February 2017

Date of mailing of the international search report

06/03/2017

Name and mailing address of the ISA/

European Patent Office, P.B. 5818 Patentlaan 2
NL - 2280 HV Rijswijk
Tel. (+31-70) 340-2040,
Fax: (+31-70) 340-3016

Authorized officer

Reim, Klaus

INTERNATIONAL SEARCH REPORT

International application No
PCT/US2016/052438

C(Continuation). DOCUMENTS CONSIDERED TO BE RELEVANT		
Category*	Citation of document, with indication, where appropriate, of the relevant passages	Relevant to claim No.
X	US 2005/211466 A1 (KAYSER RALPH [CH]) 29 September 2005 (2005-09-29)	1-4,8, 17,23,24
Y	Abstract, Desc. [0021]-[0023], Fig. 1, 3	9-12, 14-16,22
Y	----- Hygrosens: "ELEKTROLYTHISCHER FEUCHTESENSOR EFS-10", 31 August 2006 (2006-08-31), XP055346068, Retrieved from the Internet: URL: http://www.mikrocontroller.net/attachment/42166/EFS10.pdf [retrieved on 2017-02-15]	9-12
A	Page 1 - characteristics section / l. 1-32, Page 3 electronic circuit example / l. 1-21	1-4, 14-16,22
Y	----- US 2007/103170 A1 (DEHART SCOTT A [US]) 10 May 2007 (2007-05-10)	10,12
A	Abstract, Desc. [0008], Fig. 1	1-4,8,9, 11, 14-16,22
Y	----- WO 2014/191619 A1 (VAISALA OYJ [FI]) 4 December 2014 (2014-12-04)	14-16,22
A	Abstract, Desc. p. 1 / l. 3-4, p. 6 / l. 17-19, p. 7 / l. 16-18, Figs. 2a, 2b, 3b	1-4,8-13

INTERNATIONAL SEARCH REPORT

International application No.
PCT/US2016/052438

Box No. II Observations where certain claims were found unsearchable (Continuation of item 2 of first sheet)

This international search report has not been established in respect of certain claims under Article 17(2)(a) for the following reasons:

1. Claims Nos.:
because they relate to subject matter not required to be searched by this Authority, namely:

2. Claims Nos.:
because they relate to parts of the international application that do not comply with the prescribed requirements to such an extent that no meaningful international search can be carried out, specifically:

3. Claims Nos.:
because they are dependent claims and are not drafted in accordance with the second and third sentences of Rule 6.4(a).

Box No. III Observations where unity of invention is lacking (Continuation of item 3 of first sheet)

This International Searching Authority found multiple inventions in this international application, as follows:

see additional sheet

1. As all required additional search fees were timely paid by the applicant, this international search report covers all searchable claims.

2. As all searchable claims could be searched without effort justifying an additional fees, this Authority did not invite payment of additional fees.

3. As only some of the required additional search fees were timely paid by the applicant, this international search report covers only those claims for which fees were paid, specifically claims Nos.:

1-4, 8-17, 22-24

4. No required additional search fees were timely paid by the applicant. Consequently, this international search report is restricted to the invention first mentioned in the claims; it is covered by claims Nos.:

Remark on Protest

- The additional search fees were accompanied by the applicant's protest and, where applicable, the payment of a protest fee.
- The additional search fees were accompanied by the applicant's protest but the applicable protest fee was not paid within the time limit specified in the invitation.
- No protest accompanied the payment of additional search fees.

FURTHER INFORMATION CONTINUED FROM PCT/ISA/ 210

This International Searching Authority found multiple (groups of) inventions in this international application, as follows:

1. claims: 1-4, 17, 23, 24

A process variable transmitter, solving the problem of monitoring moisture in the second cavity close by the terminal block, thereby surveilling the terminal block.

2. claims: 5-7

A process variable transmitter, solving the problem of enhancing the measurement accuracy of the moisture sensor.

3. claims: 8-13

A process variable transmitter, solving the problem of enhancing the efficiency of the electronic circuit.

4. claims: 14-16, 22

A process variable transmitter, solving the problem of measuring moisture at different locations.

5. claims: 18-21

A process variable transmitter, solving the problem of indicating critical moisture levels inside the process variable transmitter.

6. claims: 25, 26

A process variable transmitter, solving the problem of enhancing the measurement quality of the measurement circuitry.

INTERNATIONAL SEARCH REPORT

Information on patent family members

International application No PCT/US2016/052438

Patent document cited in search report	Publication date	Patent family member(s)	Publication date
US 6701274	B1	02-03-2004	
		AU 7075500 A	26-03-2001
		CN 1371475 A	25-09-2002
		DE 60016422 D1	05-01-2005
		DE 60016422 T2	03-11-2005
		EP 1206689 A1	22-05-2002
		JP 3515558 B2	05-04-2004
		JP 2003508742 A	04-03-2003
		US 6701274 B1	02-03-2004
		WO 0116571 A1	08-03-2001
DE 102011088302	A1	13-06-2013	
		CN 104040302 A	10-09-2014
		DE 102011088302 A1	13-06-2013
		EP 2791631 A1	22-10-2014
		US 2015016075 A1	15-01-2015
		WO 2013087388 A1	20-06-2013
WO 2014203553	A1	24-12-2014	
		CN 105393114 A	09-03-2016
		DE 112014002928 T5	10-03-2016
		JP 2015004609 A	08-01-2015
		US 2016139071 A1	19-05-2016
		WO 2014203553 A1	24-12-2014
US 2005211466	A1	29-09-2005	NONE
US 2007103170	A1	10-05-2007	NONE
WO 2014191619	A1	04-12-2014	
		CN 105229463 A	06-01-2016
		EP 3004868 A1	13-04-2016
		US 2016084811 A1	24-03-2016
		WO 2014191619 A1	04-12-2014