

C. KENDALL.
Feather Renovator.

No. 132,838.

Patented Nov. 5, 1872.

Fig: 1

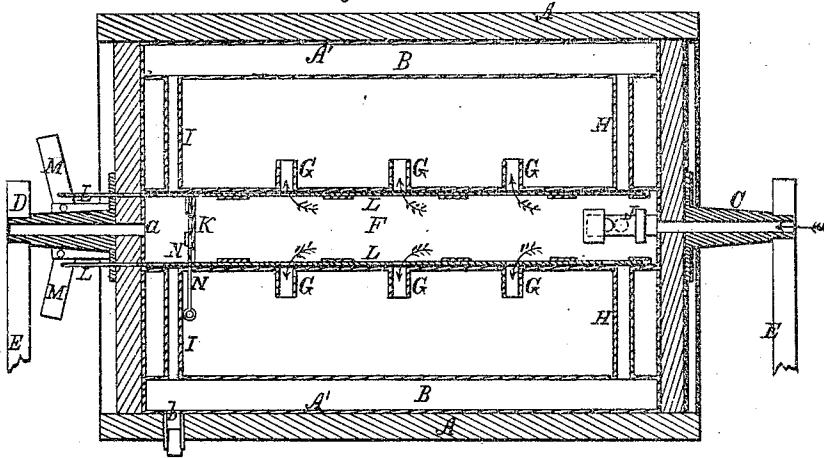

Fig: 2

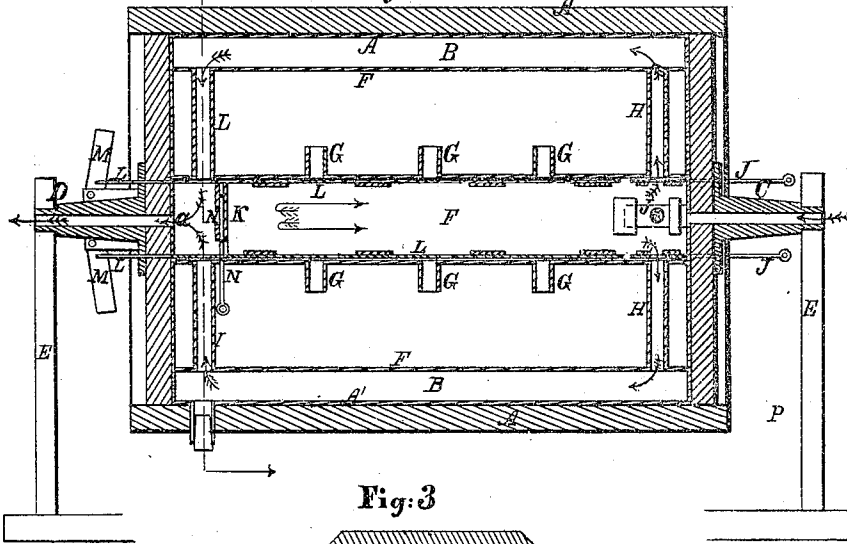
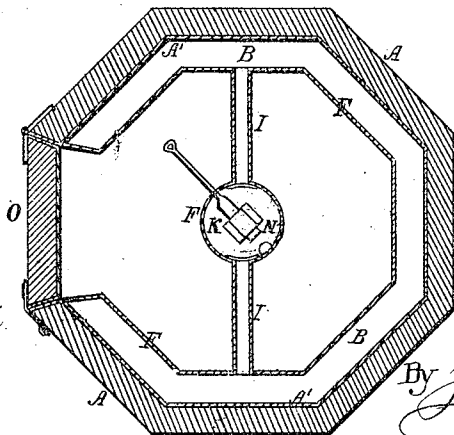

Fig: 3



Witnesses:

Westhaguer
Eugene C. Adams

Inventor:

Charles Kendall

By *Johnson, Mauere & Co*
his Attorneys.

UNITED STATES PATENT OFFICE.

CHARLES KENDALL, OF BELOIT, WISCONSIN.

IMPROVEMENT IN FEATHER-RENOVATORS.

Specification forming part of Letters Patent No. 132,838, dated November 5, 1872.

To all whom it may concern:

Be it known that I, CHARLES KENDALL, of Beloit, in the county of Rock and State of Wisconsin, have invented a new and useful Improvement in Renovators and Driers for Feathers, Hair, and Moss, of which the following is a specification:

My invention relates to machines for renovating and drying feathers and other similar material; and the invention, which forms the subject-matter of this patent, consists in providing the central steam-jet cylinder with a partition near one end thereof, in combination with branch tubes arranged at the opposite ends of said central cylinder and on opposite sides of its partition, one set of said branch tubes forming a communication with an outer heating-chamber at one end of said inner cylinder, and the other set forming an outlet from said outer heating-chamber with the exit end of the central cylinder; the object of which arrangement is to convert the renovator into a drier and have a free and uninterrupted flow at the same time of the steam not only into the inner cylinder from one end to the other, but directly from it into and through the outer chamber, from one end of which it escapes from the two heating and drying chambers, thereby producing a renovator by the steam-jets from the inner cylinder, and a drier from both the inner and outer chambers, as will be hereinafter more fully explained.

In the accompanying drawing, Figure 1 represents a horizontal section of a renovator and drier embracing my invention as adapted for renovating; Fig. 2 represents a similar section of the same as adapted for drying; and Fig. 3, a transverse section of the same, showing the valved partition of the inner cylinder.

The renovator and drier consist of a cylindrical or other shaped case, A, having an outer or surrounding drying-chamber, B, supported upon tubular bearings C D at each end thereof, upon a frame, E, so as to be revolved thereon, and an inner sheet-metal central cylinder, F, for receiving steam direct from the boiler for renovating and drying. The inner lining A' of the surrounding chamber B is made of sheet metal to form an inner heat-radiating surface, and the outer case is of wood to hold the heat to the inner lining. The central cyl-

inder F is provided with a series of jet-tubes, G, to admit the steam into the feathers for renovation. The inlet end of this cylinder F has three branch tubes, H, which communicate with the surrounding chamber B, and the exit-end thereof has two branch tubes, I, also communicating with said surrounding chamber. The first series of tubes, H, are provided with valves J for closing the communication between the inner and outer chambers F B when renovating, as shown in Fig. 1, and the second series, I, form a perpetual communication with these chambers and the exit-opening a of the hollow bearing D, and which are only open to the perpetual communication for the free escape of the steam from the boiler when the valves J of the first-named branch tubes are open, as shown in Fig. 2 of the drawing. To effect this the central cylinder F is provided with a partition, K, located between the exit-tubes I from the surrounding chamber and the inner jet-tubes G, so that the central cylinder is always closed at one end to the incoming steam, and put in communication at the other end with the surrounding chamber B by opening the valves J only when the feathers have been sufficiently renovated and require to be dried, in which case the jet-tubes G are closed by interior slides L operated by hand-levers M at the exit-bearing D of the case, as shown in Fig. 2. The inlet and outlet tubular bearings C D of the revolving case are secured to the heads thereof so as to form a direct communication with the central cylinder, but not through it, the special feature of my invention necessitating the circulation of the drying-steam or hot air within the entire length of and from said central cylinder at one end only into one end of the surrounding chamber B, and out at the other end thereof through the same central tube F at which it first entered, thus passing into one end and out of the other, but not in the same direct line, by which arrangement I am enabled to obtain an interior and an outer heating-surface surrounding the material by one and the same current of steam direct from the boiler. The partition K for the central tube F is provided with a valve, N, to let out therefrom the condensed steam, which passes off through the tubes I into the outer chamber B, from whence

it passes through the opening *b*. By this arrangement the water in the central cylinder may be blown out by steam direct from the boiler when the partition-valve *N* is open and the cylinder otherwise closed. The water from the surrounding case is let out by removing a plug in the outer case. The outer case has a door, *O*, for filling and removing the material when treated, and the case is held in position for the purpose by means of a hook, *P*, from the frame.

Having described my invention, I claim—

1. In a feather renovator and drier, the central cylinder *F*, provided with a partition, *K*,

at one end, in combination with the branch tubes *H I*, the surrounding chamber *B*, and the inlet and outlet hollow bearing *C D*, as and for the purpose described.

2. The renovator and drier herein described, having all its parts constructed and arranged for joint operation, as set forth and shown in the drawing.

In testimony whereof I have hereunto set my hand this 2d day of October, A. D. 1872.

CHARLES KENDALL.

Witnesses:

R. TATTERSHALL,
L. W. KENDALL.