

W. B. QUARTON.

FEEDING-BELT AND PARTITION FOR CORN-SHELLERS.

No. 170,897.

Patented Dec. 7, 1875.

Fig. 1.

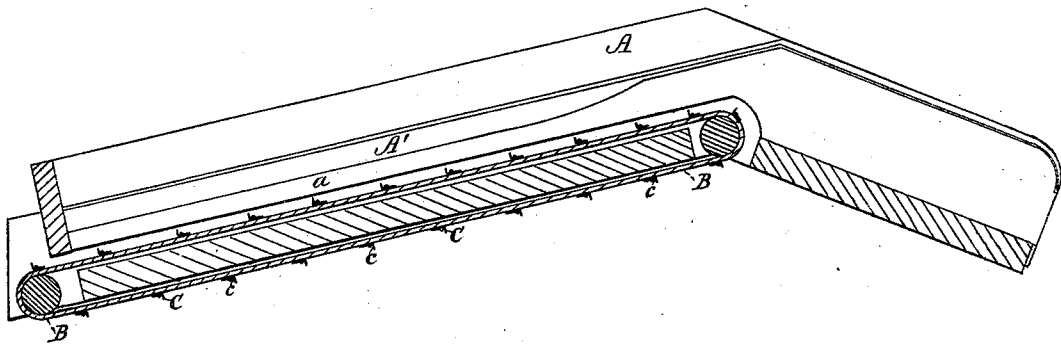
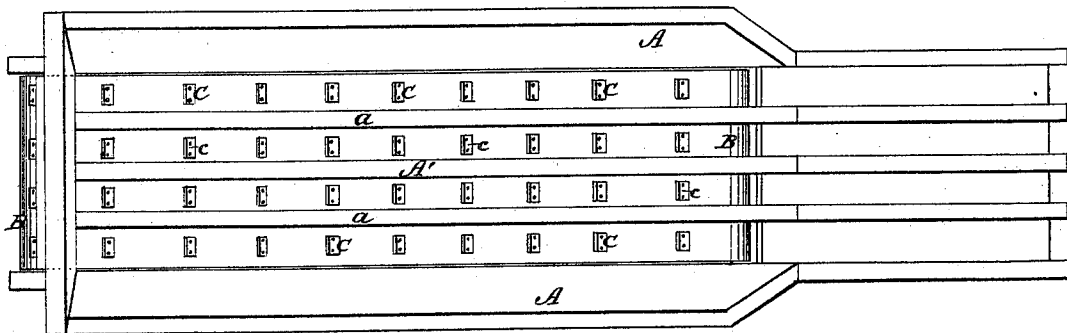

Fig. 2.



WITNESSES:

*Wm. Hollingsworth*  
*John C. Kemou*

INVENTOR:

*Wm. B. Quarton*

BY

*Wm. F. L.*

ATTORNEYS.

# UNITED STATES PATENT OFFICE.

WILLIAM B. QUARTON, OF FREMONT, IOWA.

IMPROVEMENT IN FEEDING-BELTS AND PARTITIONS FOR CORN-SHELLERS.

Specification forming part of Letters Patent No. 170,897, dated December 7, 1875; application filed June 25, 1875.

*To all whom it may concern:*

Be it known that I, WILLIAM B. QUARTON, of Fremont, in the county of Mahaska and State of Iowa, have invented a new and Improved Corn-Sheller; and I do hereby declare that the following is a full, clear, and exact description of the same, reference being had to the accompanying drawing, forming a part of this specification, in which—

Figure 1 is a longitudinal sectional elevation; Fig. 2, a plan view.

The invention relates to a corn-sheller having four or more feeding holes or throats that receive ears independently; and consists in improving the feeder for such a machine, as hereinafter will first be described in connection with the drawing, and then pointed out in the claims.

A represents a feed-box for a quadruple sheller, which is usually provided with four independent belts, and separated into as many channel-ways for the corn. The dividers *a*, that are now employed for this purpose, are about half an inch high above the belts. This allows the corn to fall backward as it ascends, so that the inside belts or channels do not feed so fast as the outside ones. I place between the two inner channels a divider, *A'*, that is four inches high, and which entirely obviates the difficulty.

With this improvement the machine is found to shell about fifteen bushels per hour more than before.

If the machine has a feeder with six channels, there will be required two of my dividers, and so on in proportion.

The independent belts—one for each channel—will sometimes catch and slip, while dirt, trash, and snow will also work in on the pulleys, above and below, as well as between, the belts, thus making it difficult to operate the feeder. In order to overcome this objection I make a broad belt, *B*, passing under all the channels, as shown in the drawing.

By means of my partitions *A'*, which are of uniform and unvarying height, higher than the intervening partition, and located al-

ternately with the lower partitions, it will be seen that the corn cannot be supported transversely upon the feeder, and the ears are compelled to arrange themselves longitudinally, and in such a manner as to be always in the range of the buckets and in position to be carried up.

The buckets *C*, that transfer the corn, are now riveted on the belts, about an inch, or an inch and a half, from the turn or bend *c* of the metal forming the bucket. This allows them, when turning the pulley at the top, to project some distance, and catch the ear of corn as it passes over, thereby stopping the belt. To obviate this objection I rivet the buckets to the belt, close up to the turn or bend of the metal, by means of which arrangement the buckets are made to project a less distance in turning the pulley, and the chances of catching the ends of the ears of corn and the stoppage of the belt diminished accordingly.

I am aware of the fact that a feeder for a corn-sheller has been constructed in which the partitions are all alike, and of greater height at the top than at the bottom; but with this construction the ears of corn, which are dumped in promiscuously at the lower end from a basket, are very slow to arrange themselves in longitudinal direction, and a large number of buckets go up empty, and the feeding capacity is proportionally limited.

Having thus described my invention, what I claim as new is—

1. The combination, with a corn-sheller feeder, of the partitions *A'*, of greater height than the intervening partitions, and alternating in position with the same, so as to divide the channels into sets of two each, substantially as and for the purpose described.

2. The combination, in a feeder, with the series of dividers, forming channels, of a single broad subjacent belt, *B*, as and for the purpose set forth.

WILLIAM B. QUARTON.

Witnesses:

S. W. POKKLINGTON,  
R. T. NEWELL.