

*J. D. James, Jr.*

*Seaming Metal Roofs.*

*N<sup>o</sup> 100,414.*

*Patented Mar. 1, 1870.*

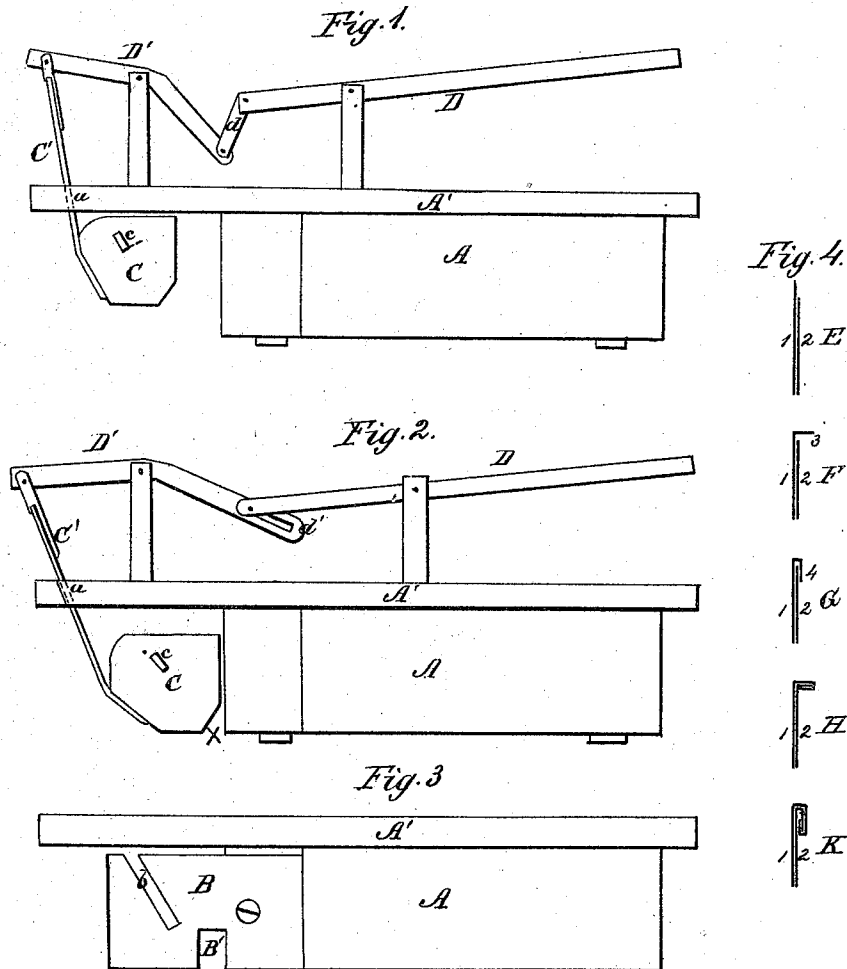

*Witnesses:*

*Edwin James*

*Alf. Holmead Jr.*

*Inventor:*

*J. Dawson James, Jr.*

*per J. E. F. Holmead*

*Attorney.*

# United States Patent Office.

JOHN DAWSON JAMES, JR., OF WASHINGTON, DISTRICT OF COLUMBIA, ASSIGNOR TO HIMSELF, ADOLF BODE, AND JACOB D. C. OUTWATER, OF NEWARK, NEW JERSEY.

Letters Patent No. 100,414, dated March 1, 1870.

## IMPROVEMENT IN MACHINES FOR SEAMING METAL ROOFS.

The Schedule referred to in these Letters Patent and making part of the same.

To all whom it may concern:

Be it known that I, JOHN DAWSON JAMES, JR., of Washington city, and District of Columbia, have invented certain new and useful Improvements in Machines for Seaming Metal Roofs; and I do hereby declare that the following is a full, clear, and exact description of the same, reference being had to the accompanying-drawing and to the letters of reference marked thereon making part of this specification, in which—

Figure 1 is a side view, with the guide-plate removed, the swage-head being raised.

Figure 2 is a side view, with the guide-plate removed, the swage-head being down.

Figure 3 is a side view, with the guide-plate in position.

Figure 4 illustrates the different stages through which the tin passes in forming the seam-joint.

The object of my present invention, like the tongs for which I have filed an application for Letters Patent, the same bearing even date herewith, is to facilitate the operation of roofing, dispensing entirely with the immense manual labor which the grooving-iron and mallet, as now used, require, and also to protect the tin from all breakage caused by uneven blows from the mallet, or its cutting at the points of indentation caused by the blow.

My improved swage and tongs accomplish the entire work, the latter pressing the tin in such position as readily to accommodate itself to the action of the swage, which, by simply depressing a lever, completes the joint.

The nature of my invention consists in securing in or forming with a suitable base-block or frame two guide or bearing-plates.

These plates are provided with vertical grooves, that fit over the seams and angular slots, in which work projecting pins on the swage or hammer-head, and which direct the movement of the same, causing it, in its fall, to meet the metal at the desired point, and pressing it, as the swage descends, to such position as to complete the seam-joint.

The swage has attached to it a plate-handle, which is slightly curved, so as to afford the desired sweep.

The swage or hammer is attached to a compound lever, which works on suitable fulcrum-pins or arms secured on the upper face of the base-block.

This device, like the tongs, is equally as well adapted for the working of copper and other metals as tin.

To enable others skilled in the art to make and use my invention, I will now proceed to describe its construction and operation.

A is the base-block or frame, and may be constructed of any suitable metal or wood. This block may be of any desired dimensions. I usually make it, say, twelve by fourteen inches.

The face-plate A' of the block projects beyond its main surface, as clearly shown in the drawing.

B B are two metallic guide-plates. These plates may be attached to the block by screws, as shown in fig. 3; or, when the block is made of cast metal, they may be cast with it.

These plates are formed with two slots—a vertical slot, B', and an inclined slot, b. This slot B' enables the instrument to be properly set and adjusted over the seams, so that the swage, by its falling pressure, can form the joint.

In the inclined slot b work the guide-pins c c.

These pins c c are secured to the swage or hammer-head C, and, projecting laterally therefrom, pass through the slots b b. The swage or hammer-head C is made of metal or other suitable material, and substantially in the form shown in figs. 1 and 2. This swage may be of any desired dimensions. I usually make it, say, from ten to twelve inches across its face.

C' is the handle of the swage, and is slightly curved in form.

This handle passes through a slot, a, in the front of the face-plate A' of the block or base, and is either cast with the swage or otherwise secured thereto.

D is a straight, and D', a bent or curved lever.

These levers are connected by a link, d, or the lever D' may be slotted, as shown at d', fig. 2, and the lever D secured therein by bolt.

The outer end of the lever D' is secured to the swage-handle C', and by which means the swage C is operated, and the necessary pressure applied.

The operation is as follows:

The seams are turned up, as shown at 1 2, E, fig. 4. 1, 2, 3, F, fig. 4, represent the condition of the seams after they are pressed by my improved tongs, or after the flange 3 has been turned down or formed by grooving-iron and mallet. This is the stage of the process at which the swage is first applied, the instrument being in the position shown in fig. 1, the vertical slot B' fitting over the seams, as shown at G, when, by simply depressing the lever, the swage C is carried to the position shown at X, fig. 2, acting on the flange 3, and, by its movement, forcing the same down in position, as shown at 4, G, thus completing the first seam-joint.

H and K, fig. 4, are a mere repetition of the process just described as necessary to the formation of the first seam-joint, H representing the condition

of the seams after the second application of tongs, and K after the second application of the swage.

Having thus fully described my invention,

What I claim therein as new, and desire to secure by Letters Patent of the United States, is—

The base-block A, having slotted guide-plates B B, swage C, and handle C', when the same are connected with a system of leverage, as shown, the whole

being combined and arranged to operate substantially as described.

In testimony whereof I have signed my name to this specification in the presence of two subscribing witnesses.

Witnesses:

EDWIN JAMES,  
FRED. KOONES.

J. D. JAMES, JR.