



91362

#42

1346

(74)

:

(54)

가

가

가

가

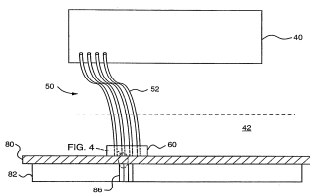

가 가

가

가  
(DUTs; devices-under-test)

I/O

가  
DUT 가  
DUT 가  
DUT 가  
(12) (14) (16) (18)  
가 (DIB, )  
1GHz 50 .50 가  
가  
1 GHz  
, 1 GHz  
( ) , 1024-  
1024 가  
, 6 DUT 6 가 0.150  
DIB  
DUT DUT DIB  
가 Saito 5,944,548  
가  
가  
가  
(distal extremities)

(distal tip)

가

DIB

(DIB)

DIB

가

1

2

3

4

2

4

5

2

50

(

)

(DIB)

가

2)  
2), 3

4

1

(50)

(5

(56, 57; 4)  
(54; 4)

(58)

9)

, Suhner Multiflex Corp.

가

, Multiflex 86

(5

(52)

(proximal end)

( )

( )

3)

(52)

(60; 2

( 2)

4

(54)

( )

(62)

(80)

(63)  
(65)

가

(70) (62) (ESD; eletro-static-discharge) (54) (56)  
 가 (72), (73), (74) 1 2 (80) Littelfuse Inc., Des Plaines, IL  
 4 (84) (80) (82) 가 (86) Fuji Poly, Inc. 가  
 ) Shin-Etsu Corp. .001 mm .004 x .004 mm (72,73,74)  
 (62) (82) ( )  
 5 (50) 100  
 102 104  
 가 106 가 110  
 4 108 112 11  
 116 , ESD (54) (56)  
 (deposit) . ESD  
 118, 120 122  
 가 50 가 가  
 2 (80) ( )  
 DUTs 가 DUTs  
 가  
 가  
 가  
 DIB  
 가

(57)

1.

가 ;

2.

1

3.

1

1

2

4.

가 ;

가

가 ;

5.

4

6.

가 ;

가

가 ;

6 7. , - - , ;

6 8. , - -

6 9. ,

10. - - , ;

ESD 11. , ;

가 , ;

;

;

;

1

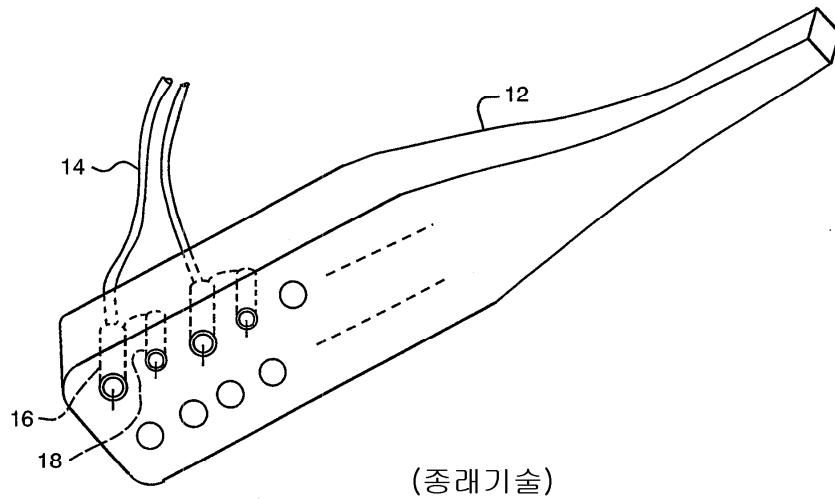

2

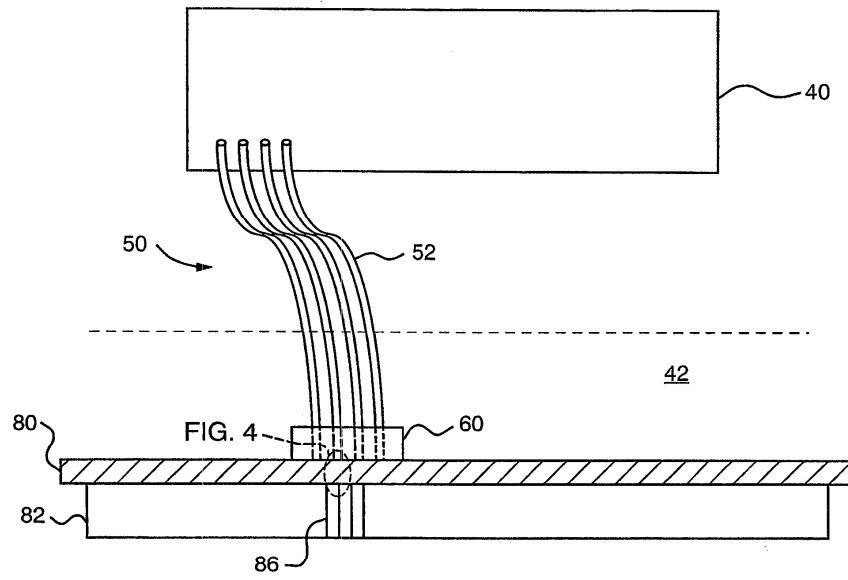

3

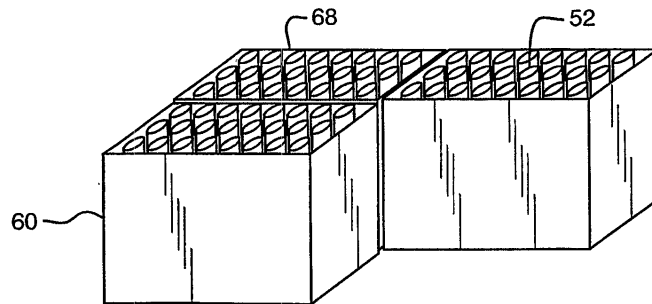



4

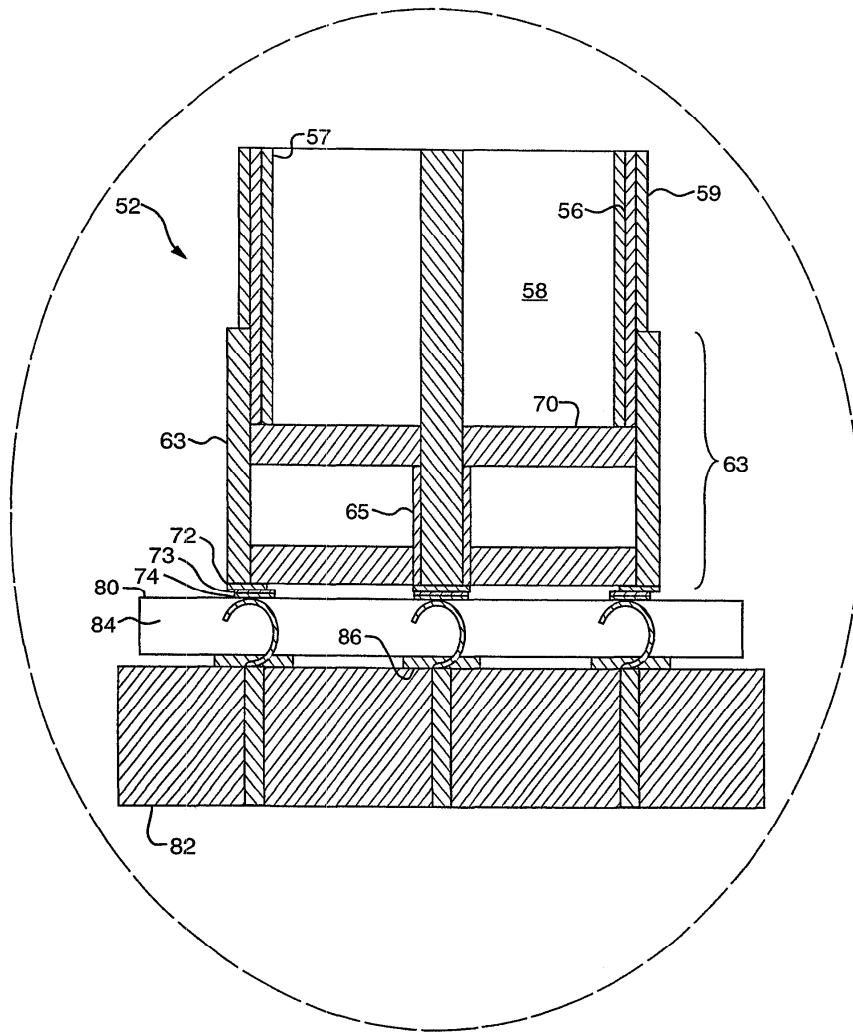

5

