



US00D596962S

(12) **United States Design Patent**
Okamoto et al.

(10) **Patent No.:** **US D596,962 S**

(45) **Date of Patent:** **** Jul. 28, 2009**

(54) **CONSTANT-TEMPERATURE INCUBATOR**

D516,925 S * 3/2006 Roher et al. D10/50

* cited by examiner

(75) Inventors: **Yasutoshi Okamoto**, Osaka (JP);
Akihiro Mochizuki, Osaka (JP)

Primary Examiner—Antoine D Davis
(74) *Attorney, Agent, or Firm*—Rabin & Berdo, PC

(73) Assignee: **Sanyo Electric Co., Ltd.**, Osaka (JP)

(57) **CLAIM**

(**) Term: **14 Years**

The ornamental design for a constant-temperature incubator, as shown and described.

(21) Appl. No.: **29/309,644**

(22) Filed: **Sep. 18, 2008**

DESCRIPTION

(30) **Foreign Application Priority Data**

Apr. 28, 2008 (JP) 2008-010845
Apr. 28, 2008 (JP) 2008-010847

FIG. 1 is a perspective view of a first embodiment of a constant-temperature incubator showing our new design;

FIG. 2 is a front elevation view of FIG. 1;

FIG. 3 is a rear elevation view of FIG. 1;

FIG. 4 is a top plan view of FIG. 1;

FIG. 5 is a bottom plan view of FIG. 1;

FIG. 6 is a right side view of FIG. 1;

FIG. 7 is a left side view of FIG. 1;

FIG. 8 is a perspective view of a second embodiment of a constant-temperature incubator showing our new design;

FIG. 9 is a front elevation view of FIG. 8;

FIG. 10 is a rear elevation view of FIG. 8;

FIG. 11 is a top plan view of FIG. 8;

FIG. 12 is a bottom plan view of FIG. 8;

FIG. 13 is a right side view of FIG. 8; and,

FIG. 14 is a left side view of FIG. 8.

(51) **LOC (9) Cl.** **10-04**

(52) **U.S. Cl.** **D10/50**

(58) **Field of Classification Search** D10/49-50;
236/5, 46 R-46 F, 47, 49.3, 51, 84, 94; 340/7.21-7.24,
340/7.32, 825.6, 825.72, 539.1, 539.14, 539.21,
340/539.26, 426.21, 584.589, 870.17; 455/420,
455/226.1

See application file for complete search history.

(56) **References Cited**

U.S. PATENT DOCUMENTS

D402,569 S * 12/1998 Papic et al. D10/50
D434,338 S * 11/2000 Odom et al. D10/49
D505,344 S * 5/2005 Roher et al. D10/50

1 Claim, 10 Drawing Sheets

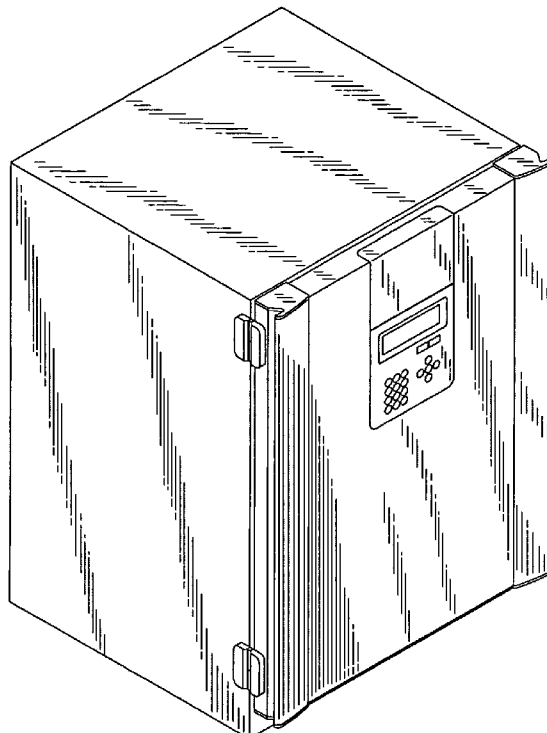

FIG. 1

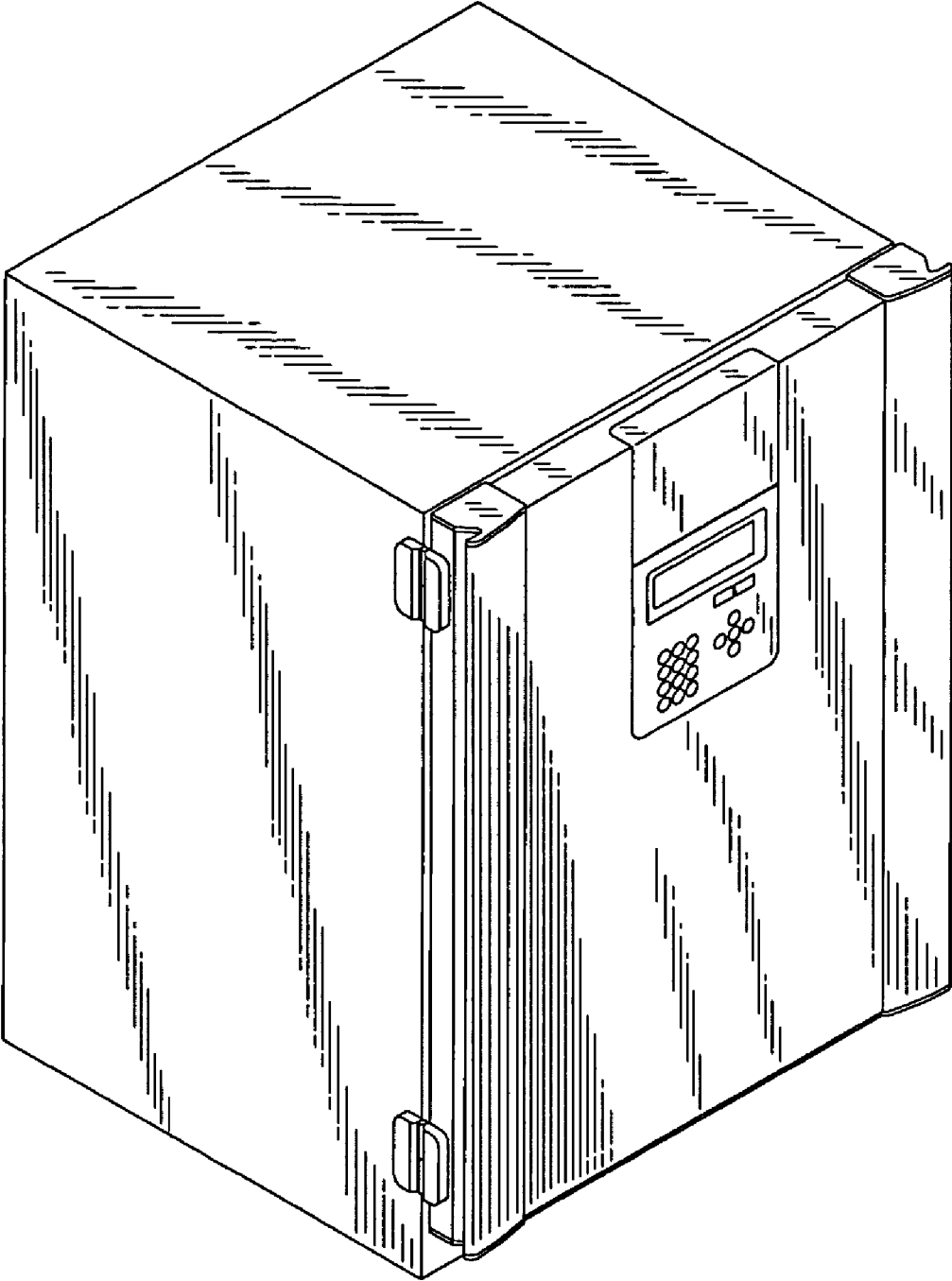

FIG. 2

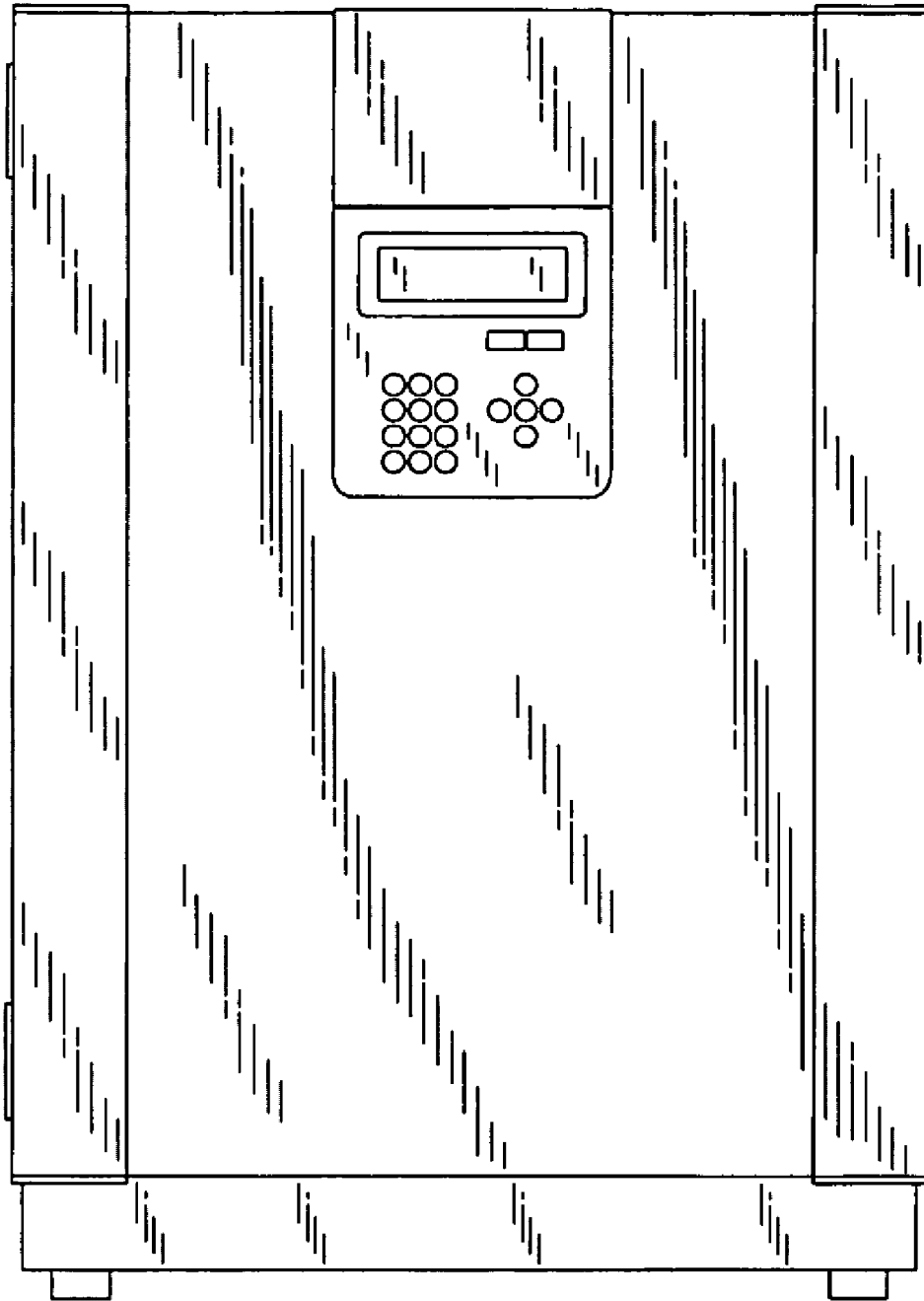

FIG. 3

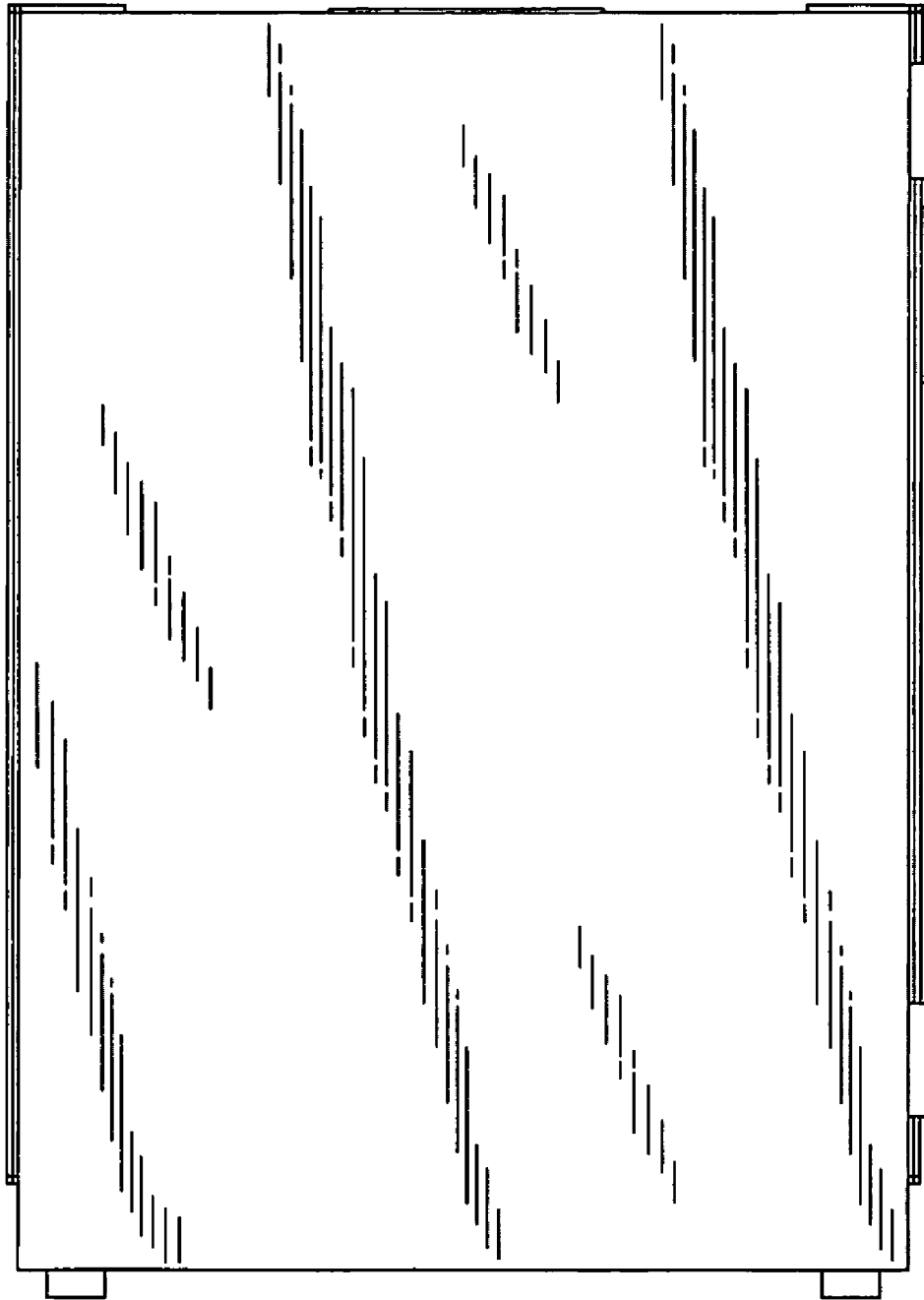

FIG. 4

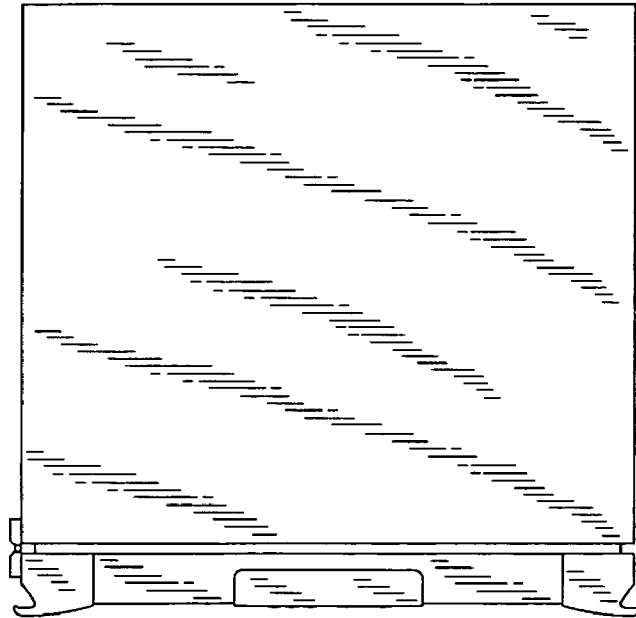

FIG. 5

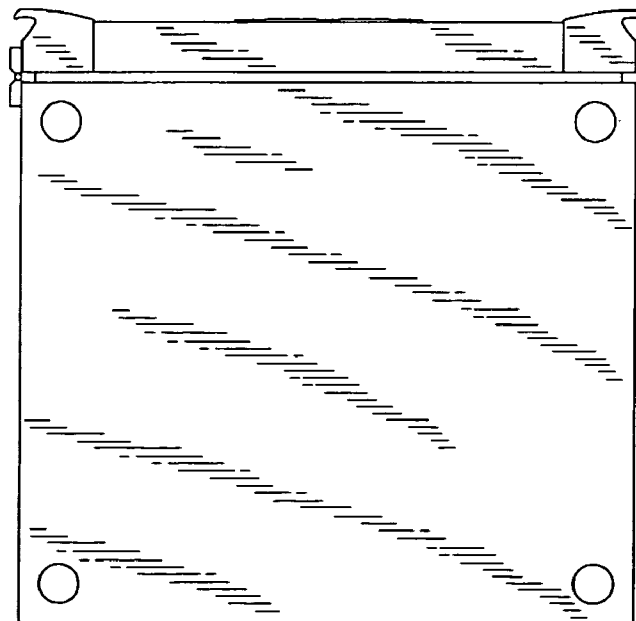

FIG. 6

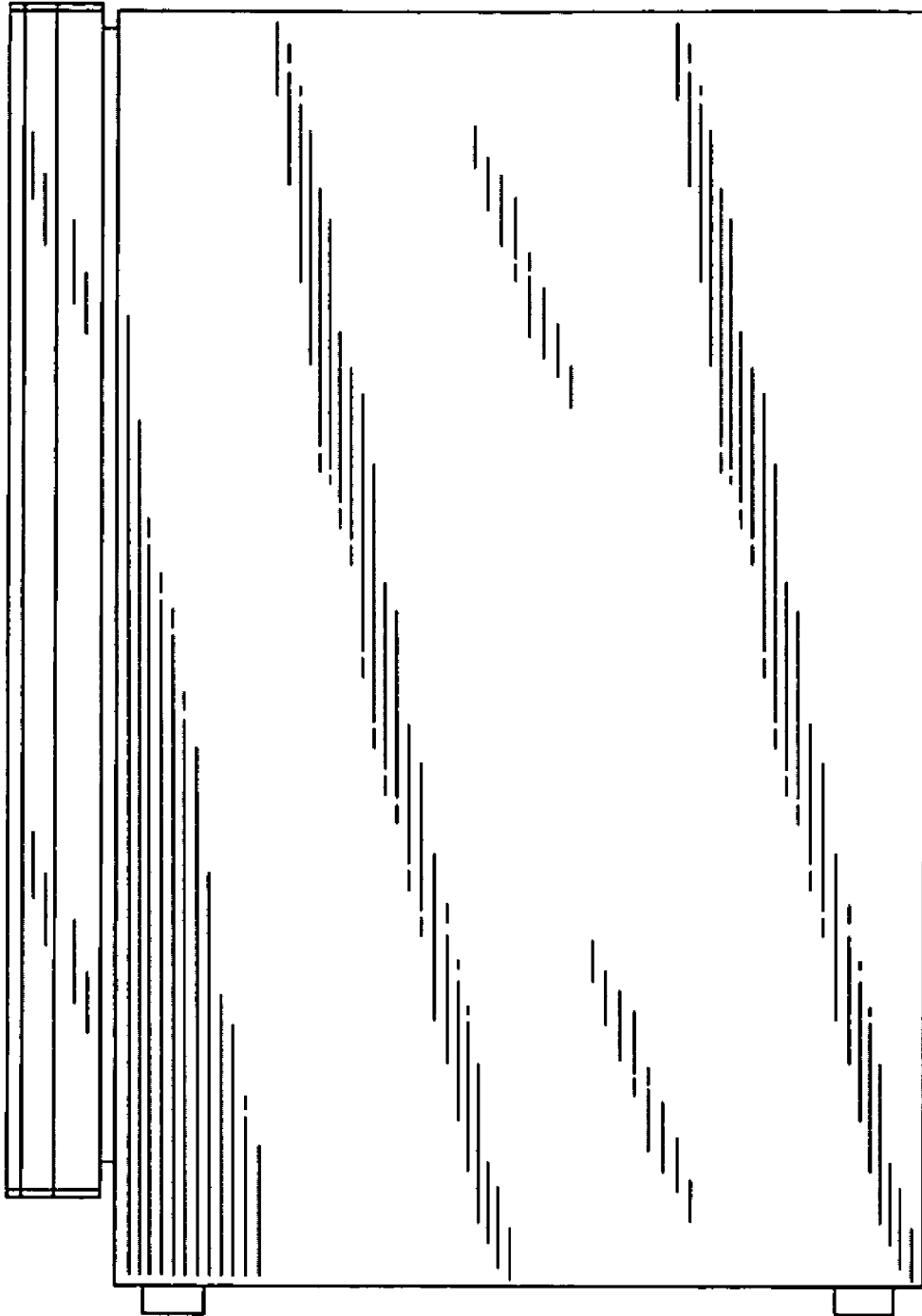

FIG. 7

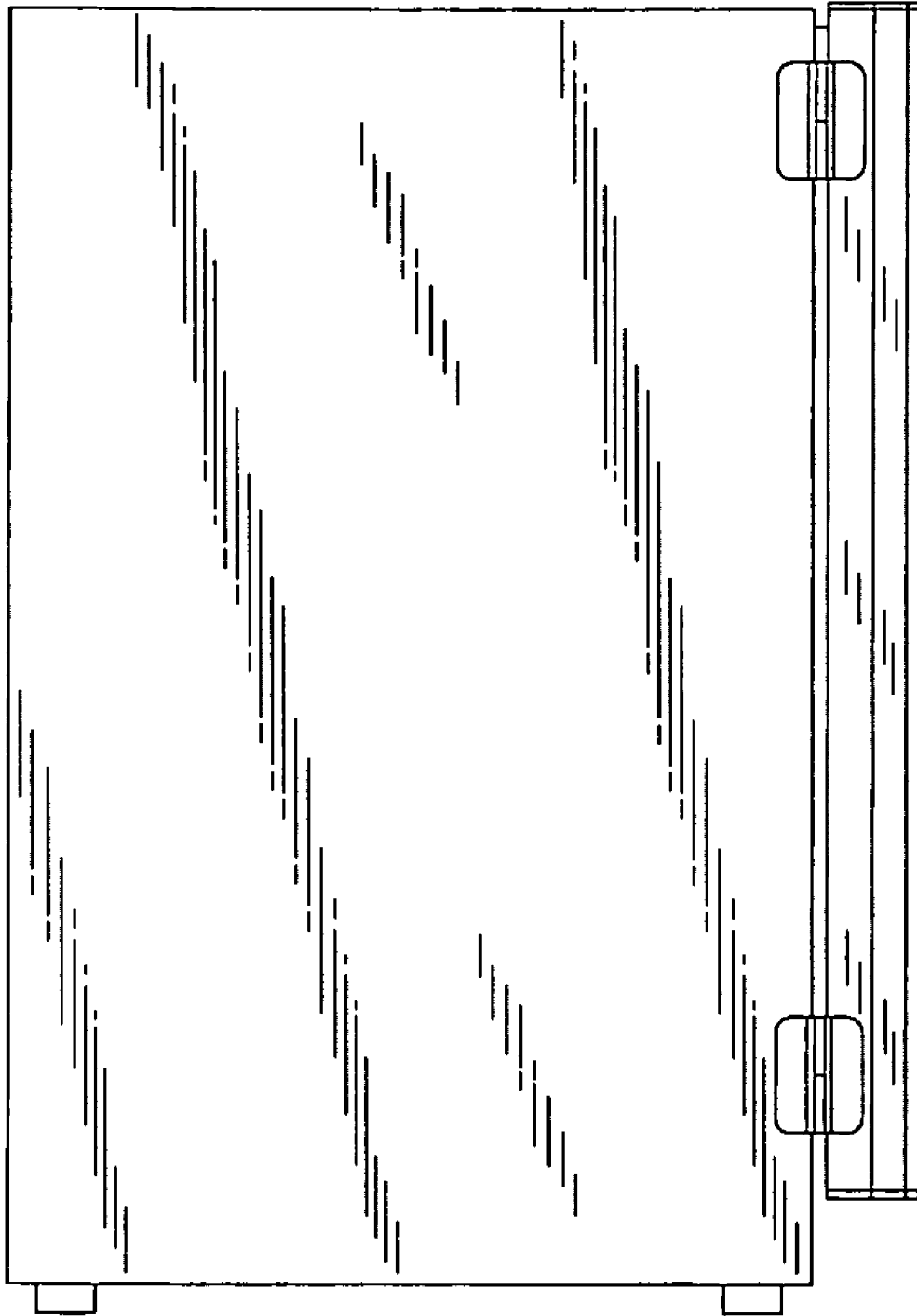

FIG. 8

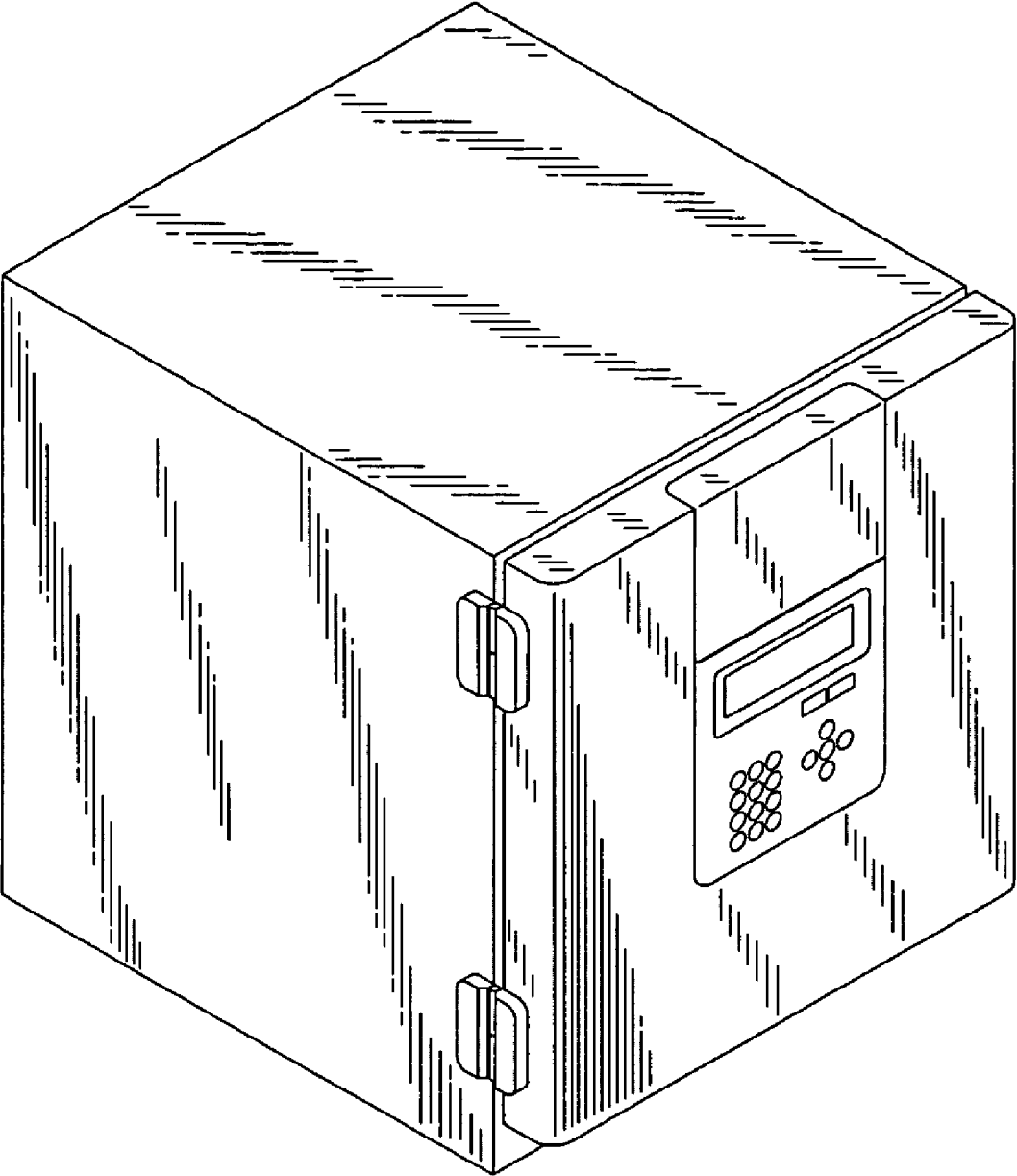

FIG. 9

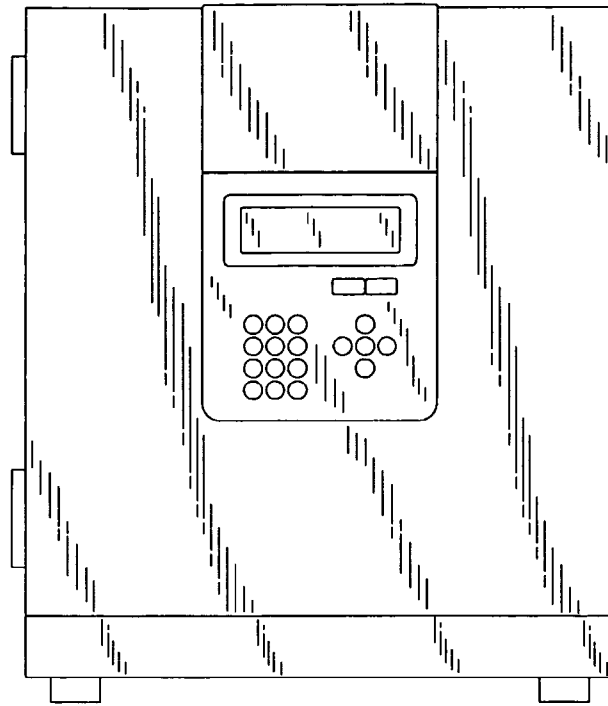

FIG. 10

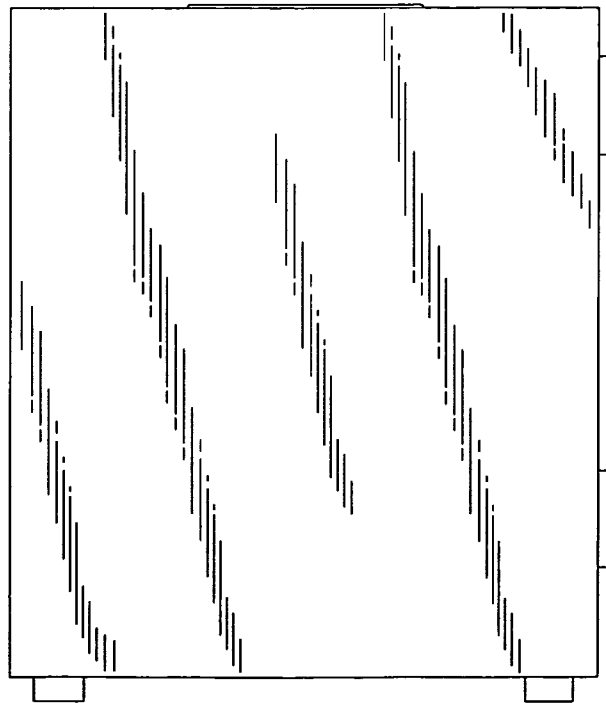

FIG. 11

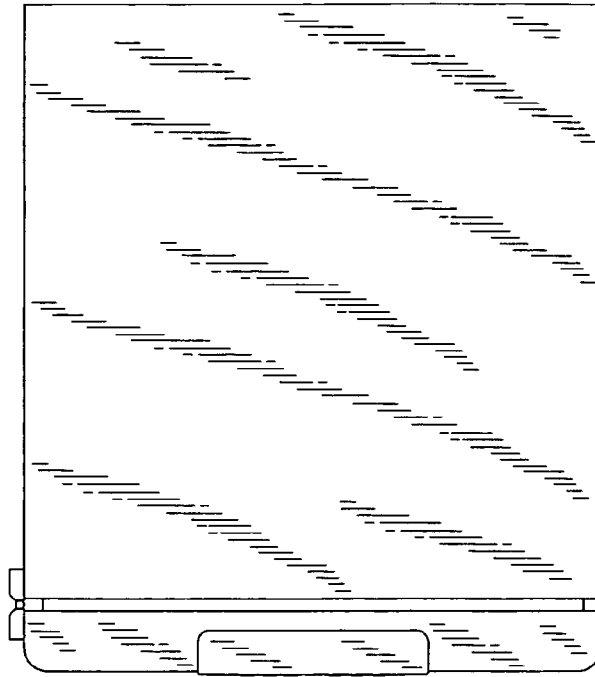

FIG. 12

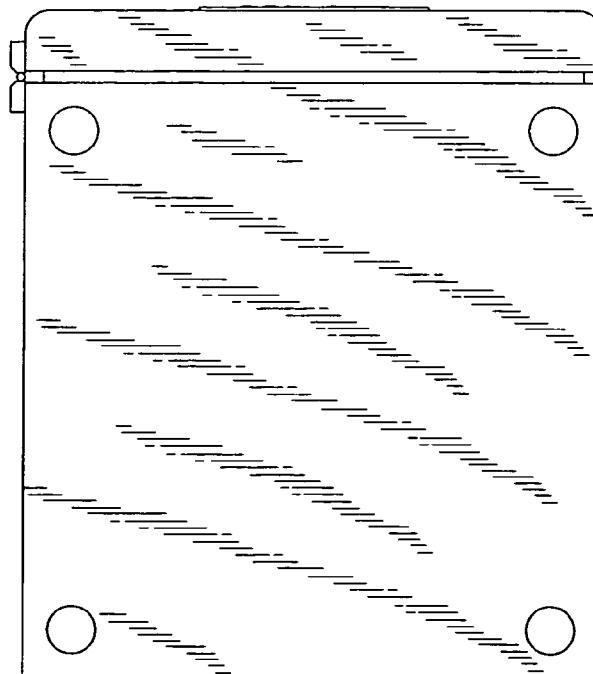

FIG. 13

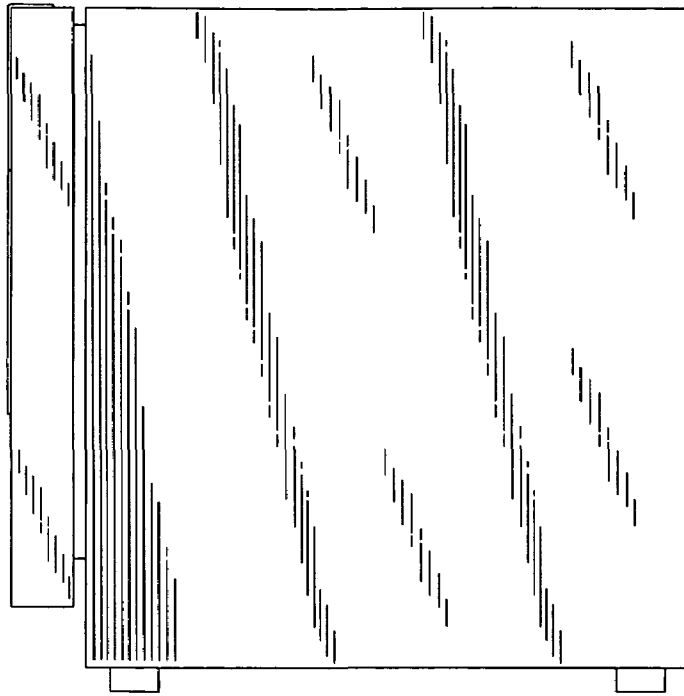

FIG. 14

