



INTERNATIONAL APPLICATION PUBLISHED UNDER THE PATENT COOPERATION TREATY (PCT)

<p>(51) International Patent Classification ⁶ : G06K 9/36, H04N 5/78, H03M 7/40</p>	<p>A1</p>	<p>(11) International Publication Number: WO 97/42593 (43) International Publication Date: 13 November 1997 (13.11.97)</p>
<p>(21) International Application Number: PCT/US97/07213 (22) International Filing Date: 29 April 1997 (29.04.97) (30) Priority Data: 08/642,742 3 May 1996 (03.05.96) US (60) Parent Application or Grant (63) Related by Continuation US 08/642,742 (CIP) Filed on 3 May 1996 (03.05.96) (71) Applicant (for all designated States except US): INTEL CORPORATION [US/US]; 2200 Mission College Boulevard, P.O. Box 58119, Santa Clara, CA 95052-8119 (US). (72) Inventors; and (75) Inventors/Applicants (for US only): LIU, Christina, K. [US/US]; 5915 Claremont Avenue, Oakland, CA 94618 (US). GOLDSTEIN, Judith, A. [US/US]; 2858 S.W. Clematis Court, Hillsboro, OR 97123 (US). NGUYEN, Yung, D. [US/US]; 17708 N.W. Reindeer Drive, Portland, OR 97229 (US).</p>	<p>(74) Agents: MURRAY, William, H. et al.; Suite 3600, 1600 Market Street, Philadelphia, PA 19103 (US). (81) Designated States: AL, AM, AT, AU, AZ, BA, BB, BG, BR, BY, CH, CN, CU, CZ, DE, DK, EE, ES, FI, GB, GE, HU, IL, IS, KE, KG, KP, KR, KZ, LC, LK, LR, LS, LT, LU, LV, MD, MG, MK, MN, MW, MX, NO, NZ, PL, PT, RO, RU, SD, SE, SG, SI, SK, TJ, TM, TR, TT, UA, UG, US, UZ, VN, YU, ARIPO patent (GH, KE, LS, MW, SD, SZ, UG), Eurasian patent (AM, AZ, BY, KG, KZ, MD, RU, TJ, TM), OAPI patent (BF, BJ, CF, CG, CI, CM, GA, GN, ML, MR, NE, SN, TD, TG). Published <i>With international search report.</i></p>	

(54) Title: VIDEO TRANSCODING WITH INTERIM ENCODING FORMAT

(57) Abstract

A method, apparatus, and storage medium for processing video data. According to one embodiment, data encoded in a first high level encoding format is partially decoded (503). The partially decoded data is encoded in accordance with a second high level encoding format (505).

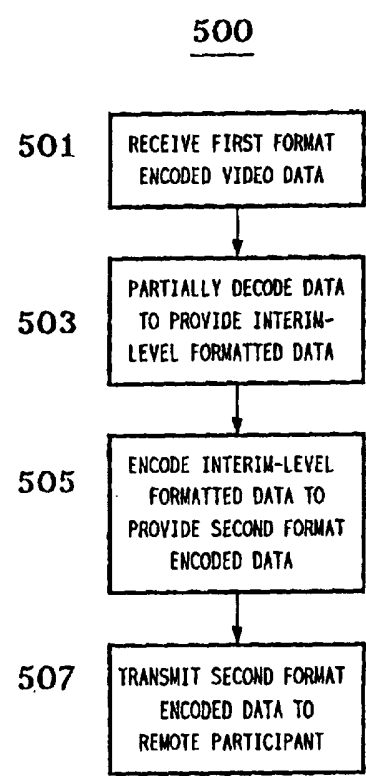

FOR THE PURPOSES OF INFORMATION ONLY

Codes used to identify States party to the PCT on the front pages of pamphlets publishing international applications under the PCT.

AL	Albania	ES	Spain	LS	Lesotho	SI	Slovenia
AM	Armenia	FI	Finland	LT	Lithuania	SK	Slovakia
AT	Austria	FR	France	LU	Luxembourg	SN	Senegal
AU	Australia	GA	Gabon	LV	Latvia	SZ	Swaziland
AZ	Azerbaijan	GB	United Kingdom	MC	Monaco	TD	Chad
BA	Bosnia and Herzegovina	GE	Georgia	MD	Republic of Moldova	TG	Togo
BB	Barbados	GH	Ghana	MG	Madagascar	TJ	Tajikistan
BE	Belgium	GN	Guinea	MK	The former Yugoslav Republic of Macedonia	TM	Turkmenistan
BF	Burkina Faso	GR	Greece			TR	Turkey
BG	Bulgaria	HU	Hungary	ML	Mali	TT	Trinidad and Tobago
BJ	Benin	IE	Ireland	MN	Mongolia	UA	Ukraine
BR	Brazil	IL	Israel	MR	Mauritania	UG	Uganda
BY	Belarus	IS	Iceland	MW	Malawi	US	United States of America
CA	Canada	IT	Italy	MX	Mexico	UZ	Uzbekistan
CF	Central African Republic	JP	Japan	NE	Niger	VN	Viet Nam
CG	Congo	KE	Kenya	NL	Netherlands	YU	Yugoslavia
CH	Switzerland	KG	Kyrgyzstan	NO	Norway	ZW	Zimbabwe
CI	Côte d'Ivoire	KP	Democratic People's Republic of Korea	NZ	New Zealand		
CM	Cameroon			PL	Poland		
CN	China	KR	Republic of Korea	PT	Portugal		
CU	Cuba	KZ	Kazakstan	RO	Romania		
CZ	Czech Republic	LC	Saint Lucia	RU	Russian Federation		
DE	Germany	LI	Liechtenstein	SD	Sudan		
DK	Denmark	LK	Sri Lanka	SE	Sweden		
EE	Estonia	LR	Liberia	SG	Singapore		

VIDEO TRANSCODING WITH INTERIM ENCODING FORMAT

BACKGROUND OF THE INVENTION

Field of the Invention

The present invention relates to the processing of video data, and, in particular, to
5 converting between different video encoding formats.

Description of the Related Art

This invention relates to signal processing which is often used to encode data signals
into an encoded bitstream and to decode such encoded bitstream to reconstruct the original
data signals. Such encoded data signals are often video image signals representative of video
10 pictures. Video pictures may be still images or may be part of a plurality of successive
pictures of video signal data that represent a motion video. As used herein, "picture" and
"video picture" may interchangeably refer to signals representative of an image as
hereinabove described.

Video formats are typically utilized to standardize ways of encoding video data. In
15 general, video data which is at the pixel level is encoded in accordance with a particular video
format that specifies the manner of encoding the video data. Such encoding may include
compressing the video data or other types of encoding. Encoded video data is encoded at a
high-level format and may thus be referred to herein as high-level video data. Video data at
the pixel or bitmap level is in a format suitable for display on a monitor or for other data
20 processing, and may be considered to be in a relatively low-level format in comparison to the
relatively high-level format at which the data is typically encoded. Video data in its high-
level, encoded format requires less storage and communications bandwidth, but is not directly
usable for processing or display, and is thus decoded before displaying the data.

Different video formats are used to represent images in computer-based image
25 processing systems. For example, one such standard is the H.261 video standard
(International Telecommunication Union (ITU), Recommendation H.261 (03/93), "Video
codec for audiovisual services at p x 64 kbits"). Often all the various elements or nodes of
a network of interconnected computers operate in a compatible video format such as H.261.
However, there may be multiple video formats, which are incompatible with each other.

Thus, for a computer configured to process (i.e., decode and encode) video data in one video format, it is unable to process video data encoded in accordance with a second format.

There is, therefore, a need for methods and apparatuses that address problems arising from incompatibilities in high-level video encoding formats.

5

SUMMARY

There is provided herein a method, apparatus, and storage medium for processing video data. According to one embodiment of the invention, data encoded in a first high level encoding format is partially decoded. The partially decoded data is encoded in accordance with a second high level encoding format.

BRIEF DESCRIPTION OF THE DRAWINGS

These and other features, aspects, and advantages of the present invention will become more fully apparent from the following description, appended claims, and accompanying drawings in which:

5 Fig. 1 is a computer system for producing encoded video signals from captured video signals, according to a preferred embodiment of the present invention;

 Fig. 2 is a computer-based decoding system for decoding the encoded video signals encoded by the encoding system of Fig. 1, according to a preferred embodiment of the present invention;

10 Fig. 3 is a networked computer system for performing transcoding, in accordance with a preferred embodiment of the present invention;

 Fig. 4 shows the transcoder of a PC of the networked computer system of Fig. 3 in further detail, in accordance with a preferred embodiment of the present invention;

 Fig. 5 is a flow chart of the method of operation of the transcoder of Fig. 4; and

15 Fig. 6 shows the architecture of a video subsystem for implementing the transcoder of Fig. 4, in accordance with a preferred embodiment of the present invention.

DESCRIPTION OF THE PREFERRED EMBODIMENT

The present invention provides for compatibility between different video encoding formats. In each high-level video format, video data at the bitmap level may be encoded in accordance with its particular high-level video encoding format. Similarly, encoded video data may be decoded in accordance with the applicable video format to provide bitmap video data suitable, for example, for display on a monitor. In order to convert encoded video data of a first video format into encoded video data of a second video format, the encoded video data is decoded to an interim-level format that lies between the encoded level and the bitmap level, and which is common to both video formats. For example, the interim-level format may be subsampled YUV-formatted video data. The interim-level video data is then encoded in accordance with the second video format.

Systems for Encoding of Captured Video Signals and Decoding of Encoded Video Signals

This section describes an exemplary encoding system to illustrate the encoding of captured video signals to produce encoded video signals, and an exemplary decoding system to illustrate the decoding of encoded video signals to produce bitmap-level video signals.

Referring now to Fig. 1, there is shown a computer system 100 for producing encoded video signals from captured video signals, according to a preferred embodiment of the present invention. This encoding is performed in accordance with the standards of a particular video format, as will be appreciated. Analog-to-digital (A/D) converter 102 of computer system 100 receives analog video signals from a video source. The video source may be any suitable source of analog video signals such as a video camera or VCR for generating local analog video signals or a video cable or antenna for receiving analog video signals from a remote source. A/D converter 102 separates the analog video signal into constituent components and digitizes the analog components into digital video component data (e.g., in one embodiment, 24-bit RGB component data). Such RGB video data is at the relatively lower bitmap or pixel level as previously described, since RGB data is in a form suitable for display on a monitor and for other processing such as image processing that operates on unencoded video data.

Capture processor 104 captures the digital 3-component video data received from converter 102. Capturing may include one or more of color conversion (e.g., RGB to YUV), scaling, and subsampling. Each captured video frame is represented by a set of three two-dimensional component planes, one for each component of the digital video data. In one

embodiment, capture processor 104 captures video data in a subsampled YUV format, such as YUV9 (i.e., YUV 4:1:1), which is discussed in further detail hereinbelow.

5 Capture processor 104 selectively stores the captured data to memory device 112 and/or mass storage device 120 via system bus 114. Those skilled in the art will understand that, for real-time encoding, the captured data are preferably stored to memory device 112, while for non-real-time encoding, the captured data are preferably stored to mass storage device 120. For non-real-time encoding, the captured data will subsequently be retrieved from mass storage device 120 and stored in memory device 112 for encode processing by host processor 116. As will be appreciated, in video conferencing systems (which use on-line, 10 real-time encoding and decoding), each PC system may receive and decode encoded signals received from the PC systems of one or more remote participants (or "endpoints" of a data conference) to play the decoded video signals locally. In other situations, encoding may be done off-line.

During encoding, host processor 116 reads the captured bitmaps from memory device 15 112 via high-speed memory interface 110 and generates an encoded video bitstream that represents the captured video data. Depending upon the particular encoding scheme implemented, host processor 116 applies a sequence of compression steps to reduce the amount of data used to represent the information in the video images. Many video compression schemes divide images into blocks of pixels for compression purposes. The 20 resulting encoded video bitstream is then stored to memory device 112 via memory interface 110. Host processor 116 may copy the encoded video bitstream to mass storage device 120 for future playback and/or transmit the encoded video bitstream to transmitter 118 for real-time transmission to a remote receiver (not shown in Fig. 1).

Referring now to Fig. 2, there is shown a computer system 200 for decoding the 25 encoded video bitstream encoded by computer system 100 of Fig. 1, according to a preferred embodiment of the present invention. In computer system 200, the video bitstream to be decoded has been encoded in accordance with a particular high-level video encoding format, and is decoded by decoding system in accordance with this video encoding format. The encoded video bitstream is either read from mass storage device 212 of decoding system 200 or received by receiver 210 from a remote transmitter, such as transmitter 118 of Fig. 1. The 30 encoded video bitstream is stored to memory device 214 via system bus 206. Decoding system 200 decodes the encoded bitstream.

Host processor 208 accesses the encoded video bitstream stored in memory device 214 via high-speed memory interface 216 and decodes the encoded video bitstream for display. Decoding the encoded video bitstream involves undoing the encoding implemented by encoding system 100 of Fig. 1. Thus, as will be appreciated, host processor 208 converts high-level format, i.e. encoded, video data to low-level video data, such as RGB data. Host processor 208 stores the resulting decoded video data to memory device 214 via memory interface 216 from where the decoded video data are transmitted to display processor 202 via system bus 206. Alternatively, host processor 208 transmits the decoded video data directly to display processor 202 via system bus 206. Display processor 202 processes the decoded video data for display on monitor 204. The processing of display processor 202 includes digital-to-analog conversion of the decoded video data.

In some video encoding formats, RGB data is converted to subsampled YUV data and is then compressed or otherwise encoded. During decoding, the encoded video data first yields subsampled YUV data, which may then be converted to RGB data. This RGB data may be converted from digital to analog by display processor 202 for display on a monitor. Thus, as will be understood, the subsampled YUV level may be considered to be an interim-level encoding format, that lies between the high-level video encoding format of the fully-encoded video signals and the bitmap-level video signals, such as RGB signals, that are suitable for display on a monitor. Decoding from a high-level video encoding format to an interim-level format may be considered to be "partial decoding," and encoding from an interim-level format to a high-level video encoding format may be considered to be "partial encoding," as will be appreciated by those skilled in the art.

When the video data has been partially decoded to provide subsampled YUV data, the interim-level video data may be upsampled (e.g., from YUV9 to YUV24) or scaled as necessary, before being further decoded to a bitmap-level format (e.g., from YUV24 to RGB24). Depending upon the particular embodiment, each of these processing steps may be implemented by either host processor 208 or display processor 202.

Referring again to Fig. 1, encoding system 100 is preferably a microprocessor-based personal computer (PC) system with a special purpose video-processing plug-in board. In particular, A/D converter 102 may be any suitable means for decoding and digitizing analog video signals. Capture processor 104 may be any suitable processor for capturing digital video component data as subsampled frames. In a preferred embodiment, A/D converter 102

and capture processor 104 are contained in a single plug-in board capable of being added to a microprocessor-based PC system.

Host processor 116 may be any suitable means for controlling the operations of the special-purpose video processing board and for performing video encoding. Host processor 5 116 is preferably a general-purpose microprocessor manufactured by Intel Corporation, such as an i486™, Pentium®, or Pentium® Pro processor. System bus 114 may be any suitable digital signal transfer device and is preferably a peripheral component interconnect (PCI) bus. Memory device 112 may be any suitable computer memory device and is preferably one or more dynamic random access memory (DRAM) devices. High-speed memory interface 110 10 may be any suitable means for interfacing between memory device 112 and host processor 116. Mass storage device 120 may be any suitable means for storing digital data and is preferably a computer hard drive. Transmitter 118 may be any suitable means for transmitting digital data to a remote receiver. Those skilled in the art will understand that the encoded video bitstream may be transmitted using any suitable means of transmission such as 15 telephone line, RF antenna, local area network, or wide area network.

Referring again to Fig. 2, decoding system 200 is preferably a microprocessor-based PC system similar to the basic PC system of encoding system 100. In particular, host processor 208 may be any suitable means for decoding an encoded video bitstream and is preferably a general purpose microprocessor manufactured by Intel Corporation, such as an 20 i486™, Pentium®, or Pentium® Pro processor. System bus 206 may be any suitable digital data transfer device and is preferably a PCI bus. Mass storage device 212 may be any suitable means for storing digital data and is preferably a CD-ROM device or a hard drive. Receiver 210 may be any suitable means for receiving the digital data transmitted by transmitter 118 of encoding system 100. Display processor 202 and monitor 204 may be any suitable devices for 25 processing and displaying video images (including the conversion of digital video data to analog video signals) and are preferably parts of a PC-based display system having a PCI graphics board and a 24-bit RGB monitor.

In a preferred embodiment, encoding system 100 of Fig. 1 and decoding system 200 of Fig. 2 are two distinct computer systems. In an alternative preferred embodiment of the 30 present invention, a single computer system comprising all of the different components of systems 100 and 200 may be used to encode and decode video images. Those skilled in the

art will understand that such a combined system may be used to display decoded video images in real-time to monitor the capture and encoding of video stream.

In alternative embodiments of present invention, the video encode processing of an encoding system and/or the video decode processing of a decoding system may be assisted by a pixel processor or other suitable component(s) to off-load processing from the host processor by performing computationally intensive operations.

Transcoding

As mentioned previously, different color formats are used to represent images in computer-based image processing systems. Standard computer monitors use a red-green-blue (RGB) color format for displaying image and graphics signals. For example, in RGB24 format, each image pixel is represented by three 8-bit component values representing the colors red, green, and blue, respectively. As will be appreciated, the RGB24 format supports 2^{24} different colors. Such an RGB format may be considered to be a low-level, or bitmap-level, format, since video data in this format is suitable for display on a monitor or for other data processing.

In the 3-component YUV color system, Y represents the luminance component and U and V represent chrominance components. In some high-level encoding formats, such as H.261, YUV-encoded data represents an interim-level format between RGB data and encoded data. One such YUV format is the YUV9 (or YUV4:1:1) format. In YUV9, each (4x4) block of image pixels is represented by a (4x4) block of 8-bit Y components, a single 8-bit U component, and a single 8-bit V component. Thus, the U and V components are said to be subsampled. As will be appreciated, each (4x4) block of pixels of the Y-component plane corresponds to a single pixel in the U-component plane and a single pixel in the V-component plane. As a result, each (4x4) pixel block is represented by $(16 \times 8 + 8 + 8)$ or 144 bits, for an average of 9 bits per pixel. Thus, the name YUV9. As will be understood, other subsampling ratios can yield other YUV formats, such as YUV12 or YUV24. Those skilled in the art will appreciate that YUV n -format data may be resampled to translate to YUV m -format data, where necessary. For example, YUV9-format data may be upsampled to provide YUV24-format data, and YUV24-format data may be subsampled to provide YUV9-format data.

Video data that is to be displayed or otherwise processed by a computer system is typically received or stored in a high-level video encoding format, such as H.261. Before displaying such video data on a monitor, for example, the computer system typically decodes the data to provide RGB data which may then be displayed on a monitor or otherwise processed. As explained above, this decoding reverses the encoding that would convert RGB video signals into the high-level video format signals.

There can arise a need for a computer system to convert a high-level format to another high-level format. Such conversion between high-level video encoding formats may be referred to herein as transcoding. Referring now to Fig. 3, there is shown a networked computer system 300 for illustrating the transcoding of the present invention, in accordance with a preferred embodiment of the present invention. System 300 comprises PCs 310, 320, and 330. PC 310 is coupled to PC 320 via bus or line 311 and PC 330 is coupled to PC 320 via line 331. PC 310 is compatible with a first high-level encoding format, Format 1, and PC 330 is compatible with a Format 2, as illustrated by captions in Fig. 3. Thus, PC 310 is configured to receive and send video data encoded in accordance with Format 1; PC 330 is configured to receive and send video data encoded in accordance with Format 2. For example, one of these Formats may be the H.261 standard, while the other is incompatible with H.261. As will be appreciated, PCs 310, 320, 330 may be computer systems similar in configuration to encoding system 100 and decoding system 200 described previously.

To transmit video data between PCs 310 and 330 it is transcoded by transcoder 320 of PC 320. Referring now to Fig. 4, there is shown the transcoder of PC 320 in further detail, in accordance with a preferred embodiment of the present invention. Transcoder 321 comprises Format 1 partial decoder 410, Format 1 partial encoder 415, Format 2 partial decoder 420, and Format 2 partial encoder 425. These encoders and decoders are referred to as "partial" because they encode to or from an interim-level format such as YUV9, as explained hereinabove.

Referring now to Fig. 5, there is shown a flow chart 500 of the method of operation of transcoder 321 of Fig. 4. First, transcoder 321 receives video data encoded at a first format (step 501). For example, Format 1 encoded video data is received by Format 1 partial decoder 410 from PC 310 via line 311. Format 1 partial decoder 410 partially decodes this first format data to generate data at an interim format (step 503), such as YUV9 formatted data, rather than fully decoding the encoded data to provide pixel-level data such as RGB

data. The YUV9 data generated by decoder 410 is input to Format 2 partial encoder 425, which is configured to encode starting from YUV9 data rather than from RGB data, and to output Format 2 encoded data (step 505). This encoded data may be transmitted to a remote node compatible with Format to, such as PC 330 via line 331 (step 507).

5 Thus, transcoder 321 converts or transcodes Format 1 encoded data to Format 2 encoded data. As will be appreciated, decoder and encoder 420, 415 may be used similarly to transcode Format 2 encoded data to Format 1 encoded data. As will be understood, one advantage of using such partial decoders and encoders in a transcoder scheme is the savings achieved in the encoding and decoding to and from the low-level format that need not be
10 performed for purposes of transcoding.

As will be understood, in one embodiment, partial decoders 410, 420 and partial encoders 415, 425 may be implemented in hardware, such as on separate PC plug-in boards containing appropriate processors and circuitry. In alternative preferred embodiments, partial
15 decoders 410, 420 and partial encoders 415, 425 may be embodied in software running on one or more programmable or special-purpose processors within a computer system such as PC 320.

Capture Engine and Playback Engine Architecture

A video subsystem architecture that may be implemented on a computer system having encoding and decoding systems such as encoding and decoding systems 100 and 200, and that
20 may be utilized to implement transcoder 321 is described hereinbelow. The present video subsystem provides for capture, encoding, and transmission of local video data to remote endpoints on the network; for receipt, decoding, and displaying of encoded video data received from remote endpoints; and for the receipt of encoded data from an endpoint, transcoding of this encoded data, and retransmission of this transcoded data to other
25 endpoints.

Referring now to Fig. 6, there is shown the architecture of a video subsystem 600, in accordance with a preferred embodiment of the present invention. Video subsystem 600 comprises capture engine 610, and playback engine 620. As will be understood, the function of a video subsystem such as video subsystem 600 is, in general, to capture and compress
30 local data; and receive, decompress and display compressed video data. The function of a capture engine such as capture engine 610 is, in general, to compress (i.e., encode) local

video data captured in raw digital form. The function of a playback engine is, in general, to decompress and provide for display compressed video received from either a remote endpoint or local compressed data received from capture engine 610. Capture engine 610 thus comprises buffer 616 and compressor 614, and playback engine 620 comprises decompressor 624 and buffer 626.

In one mode of operation, capture engine 610 receives captured digital data on line 611. This data may be generated by a video source such as a local video camera and converted from analog to digital by an A/D converter such as A/D converter 102 of encoding system 100. The data thus received by capture engine 610 is digitized but not yet encoded; for example, the data may be RGB video data. Alternatively, the data may be partially-encoded YUV data. Capture engine stores a set of data (e.g., a video frame) in buffer 616. Compressor 614 then encodes the data in buffer 616, for example by compressing it. The encoded data may be then transmitted to remote endpoints via line 613 and also transmitted to playback engine 620 so that the local video data may be displayed in a local video window on monitor 635. Thus, in this mode of operation, video subsystem 600 may act as a "front end" in a video conference, capturing and encoding local video and transmitting it to other endpoints of the conference.

Video subsystem 600 may also function as a "back end" in a video conference. In this mode of operation, encoded data such as compressed video frame data is received by playback engine 620 from a remote endpoint. The encoded data is decoded by decompressor 624 decompressing it. The encoded data may be either fully or only partially decoded, and is then stored in buffer 626. This data may then may then be displayed on monitor 635 after being suitably converted to analog signals by a display processor such as display processor 202 of decoding system 200, which is described hereinabove with reference to Fig. 2.

The above modes may be modified to allow video subsystem 600 to operate in a "transcoding mode" to transcode data in accordance with the functions of transcoder 321. Thus, encoded data may be received from one remote endpoint which is encoded in Format 1, transcoded to Format 2, and retransmitted to another endpoint.

As will be appreciated, Format 1 encoded data is received by playback engine 620 from a remote endpoint, as in the back end mode described above. The Format 1 encoded data is decoded by decompressor 624 partially decoding it, representing Format 1 partial

decoder 410 of Fig. 4. After the data is partially decoded to yield YUV or other interim level format data, it is stored in buffer 626.

5 Next, capture engine 610 is notified by playback engine 620 that transcoder mode is initiated. Once notified, capture engine 610 copies the partially decoded YUV data stored in buffer 626 into its own buffer 616. Thus, instead of receiving data in buffer 616 from a source such as a video camera, buffer 616 receives interim format data (e.g. YUV data) from playback engine 620. Then, as in the front end mode described above, compressor 614 encodes the data in buffer 616 in accordance with Format 2, representing Format 2 partial encoder 425 of Fig. 4. The encoded data may be then transmitted to remote endpoints via
10 line 613.

* * *

As will be understood, the present invention can be embodied in the form of computer-implemented processes and apparatuses for practicing those processes. The present invention can also be embodied in the form of computer program code embodied in tangible media,
15 such as floppy diskettes, CD-ROMs, hard drives, or any other computer-readable storage medium, wherein, when the computer program code is loaded into and executed by a computer, the computer becomes an apparatus for practicing the invention. The present invention can also be embodied in the form of computer program code, for example, whether stored in a storage medium, loaded into and/or executed by a computer, or transmitted over
20 some transmission medium, such as over electrical wiring or cabling, through fiber optics, or via electromagnetic radiation, wherein, when the computer program code is loaded into and executed by a computer, the computer becomes an apparatus for practicing the invention. When implemented on a general-purpose microprocessor, the computer program code segments configure the microprocessor to create specific logic circuits.

* * *

25 It will be understood that various changes in the details, materials, and arrangements of the parts which have been described and illustrated above in order to explain the nature of this invention may be made by those skilled in the art without departing from the principle and scope of the invention as recited in the following claims.

CLAIMS

What is claimed is:

- 1 1. A method for processing video data, the method comprising the steps of:
2 (a) providing data encoded in a first high level encoding format;
3 (b) partially decoding the data; and
4 (c) encoding the partially decoded data in accordance with a second high level
5 encoding format.
- 1 2. The method of claim 1, wherein the first high level encoding format is
2 incompatible with the second high level encoding format.
- 1 3. The method of claim 1, wherein the first and second high level encoding formats
2 include first and second video data compression formats, respectively.
- 1 4. The method of claim 1, wherein step (b) comprises the step of partially decoding
2 the data to provide data encoded in an interim level encoding format.
- 1 5. The method of claim 4, wherein the interim level encoding format is a YUV
2 encoding format.
- 1 6. The method of claim 4, wherein:
2 data encoded in one of the first and second high level encoding formats is not in a
3 form suitable for display on a monitor without further decoding;
4 for the first high level encoding format, the interim level encoding format lies
5 hierarchically between the first high level encoding format and a bitmap level
6 format;
7 for the second high level encoding format, the interim level encoding format lies
8 hierarchically between the second high level encoding format and the bitmap
9 level format; and
10 data in the bitmap level format is in a form suitable for display on a monitor without
11 further decoding.
- 1 7. The method of claim 6, wherein:

2 the bitmap level format is an RGB format; and
3 the interim level encoding format is a YUV encoding format.

1 8. An apparatus for processing video data, the apparatus comprising:
2 (a) means for providing data encoded in a first high level encoding format;
3 (b) means for partially decoding the data; and
4 (c) means for encoding the partially decoded data in accordance with a second high
5 level encoding format.

1 9. The apparatus of claim 8, wherein the first high level encoding format is
2 incompatible with the second high level encoding format.

1 10. The apparatus of claim 8, wherein the first and second high level encoding
2 formats include first and second video data compression formats, respectively.

1 11. The apparatus of claim 8, wherein means (b) comprises means for partially
2 decoding the data to provide data encoded in an interim level encoding format.

1 12. The apparatus of claim 11, wherein the interim level encoding format is a YUV
2 encoding format.

1 13. The apparatus of claim 11, wherein:
2 data encoded in one of the first and second high level encoding formats is not in a
3 form suitable for display on a monitor without further decoding;
4 for the first high level encoding format, the interim level encoding format lies
5 hierarchically between the first high level encoding format and a bitmap level
6 format;
7 for the second high level encoding format, the interim level encoding format lies
8 hierarchically between the second high level encoding format and the bitmap
9 level format; and
10 data in the bitmap level format is in a form suitable for display on a monitor without
11 further decoding.

1 14. The apparatus of claim 13, wherein:

2 the bitmap level format is an RGB format; and
3 the interim level encoding format is a YUV encoding format.

1 15. A storage medium encoded with machine-readable computer program code storage
2 medium for processing video data, the storage medium comprising:

- 3 (a) means for causing a computer to provide data encoded in a first high level
4 encoding format;
5 (b) means for causing the computer to partially decode the data; and
6 (c) means for causing the computer to encode the partially decoded data in accordance
7 with a second high level encoding format.

1 16. The storage medium of claim 15, wherein the first high level encoding format is
2 incompatible with the second high level encoding format.

1 17. The storage medium of claim 15, wherein the first and second high level encoding
2 formats include first and second video data compression formats, respectively.

1 18. The storage medium of claim 15, wherein means (b) causes the computer to
2 partially decode the data to provide data encoded in an interim level encoding format.

1 19. The storage medium of claim 18, wherein the interim level encoding format is a
2 YUV encoding format.

1 20. The storage medium of claim 18, wherein:
2 data encoded in one of the first and second high level encoding formats is not in a
3 form suitable for display on a monitor without further decoding;
4 for the first high level encoding format, the interim level encoding format lies
5 hierarchically between the first high level encoding format and a bitmap level
6 format;
7 for the second high level encoding format, the interim level encoding format lies
8 hierarchically between the second high level encoding format and the bitmap
9 level format; and
10 data in the bitmap level format is in a form suitable for display on a monitor without
11 further decoding.

- 1 21. The storage medium of claim 20, wherein:
2 the bitmap level format is an RGB format; and
3 the interim level encoding format is a YUV encoding format.
- 1 22. An apparatus for processing video data, comprising:
2 (a) a first format partial decoder; and
3 (b) a second format partial encoder; wherein:
4 the first format partial decoder partially decodes data encoded in a first high level
5 encoding format; and
6 the second format partial encoder encodes the partially decoded data in accordance
7 with a second high level encoding format.
- 1 23. The apparatus of claim 22, wherein the first high level encoding format is
2 incompatible with the second high level encoding format.
- 1 24. The apparatus of claim 22, wherein the first and second high level encoding
2 formats include first and second video data compression formats, respectively.
- 1 25. The apparatus of claim 22, wherein the first format partial decoder partially
2 decodes the data to provide data encoded in an interim level encoding format.
- 1 26. The apparatus of claim 25, wherein the interim level encoding format is a YUV
2 encoding format.
- 1 27. The apparatus of claim 25, wherein:
2 data encoded in one of the first and second high level encoding formats is not in a
3 form suitable for display on a monitor without further decoding;
4 for the first high level encoding format, the interim level encoding format lies
5 hierarchically between the first high level encoding format and a bitmap level
6 format;
7 for the second high level encoding format, the interim level encoding format lies
8 hierarchically between the second high level encoding format and the bitmap
9 level format; and

10 data in the bitmap level format is in a form suitable for display on a monitor without
11 further decoding.

1 28. The apparatus of claim 27, wherein:
2 the bitmap level format is an RGB format; and
3 the interim level encoding format is a YUV encoding format.

1 29. The apparatus of claim 22, further comprising:
2 (c) a second format partial decoder; and
3 (d) a first format partial encoder; wherein:
4 the second format partial decoder partially decodes data encoded in a second high level
5 encoding format; and
6 the first format partial encoder the partially decoded data in accordance with a first
7 high level encoding format.

FIG. 1. ENCODING SYSTEM

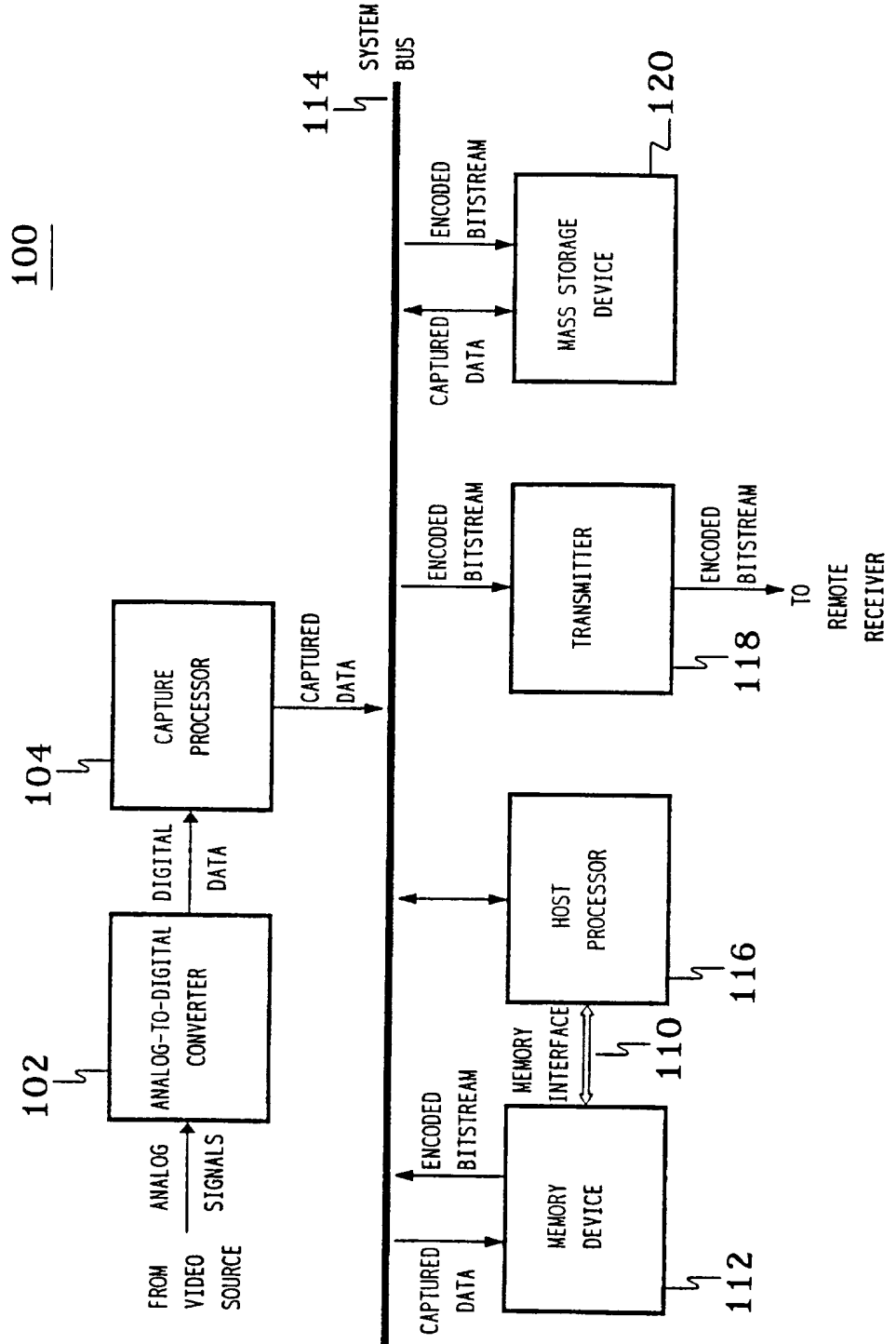

FIG. 2. DECODING SYSTEM

200

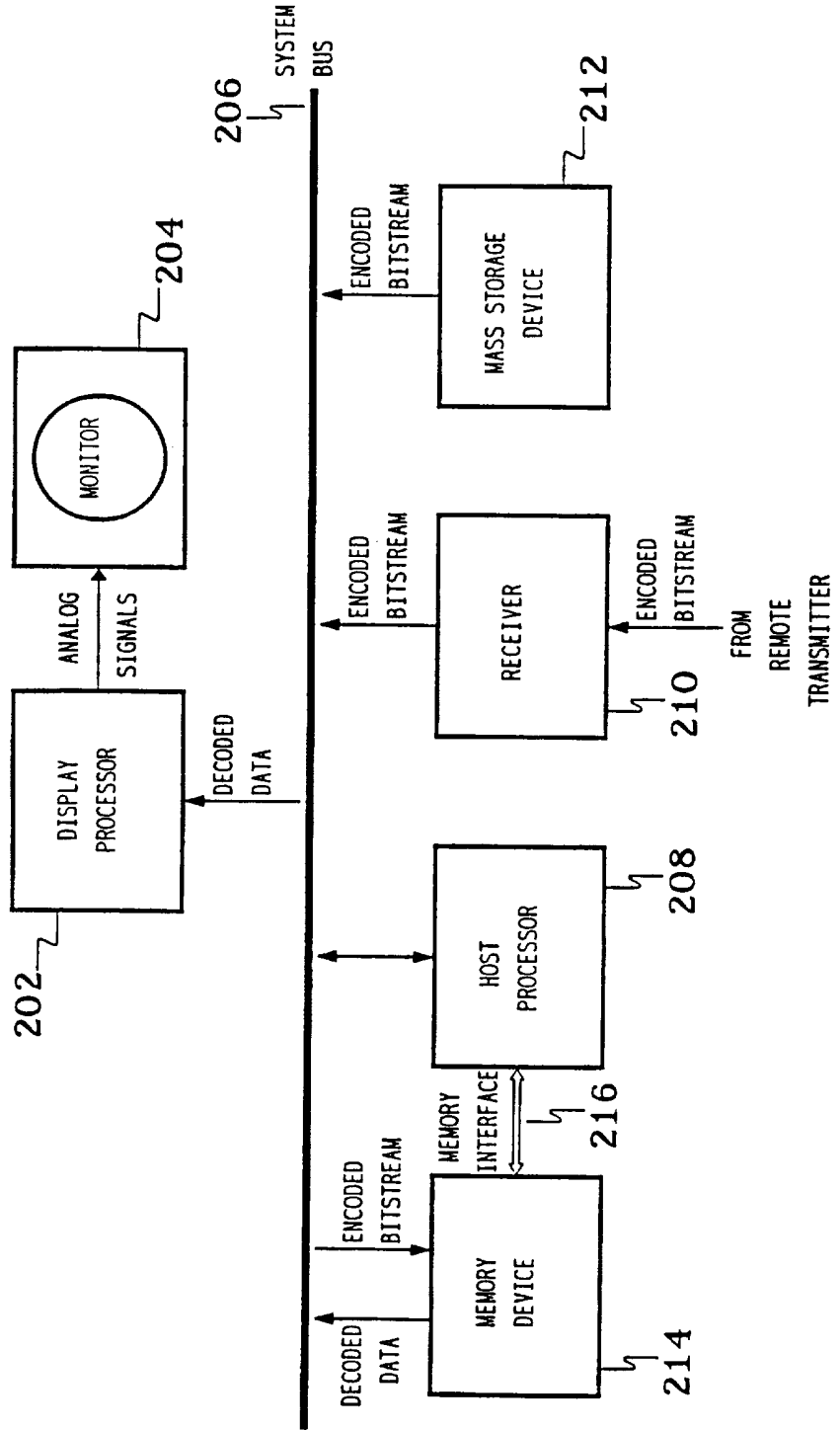

FIG. 3

300

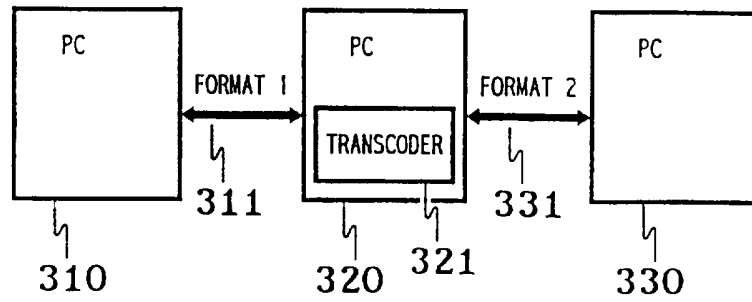

FIG. 4

321

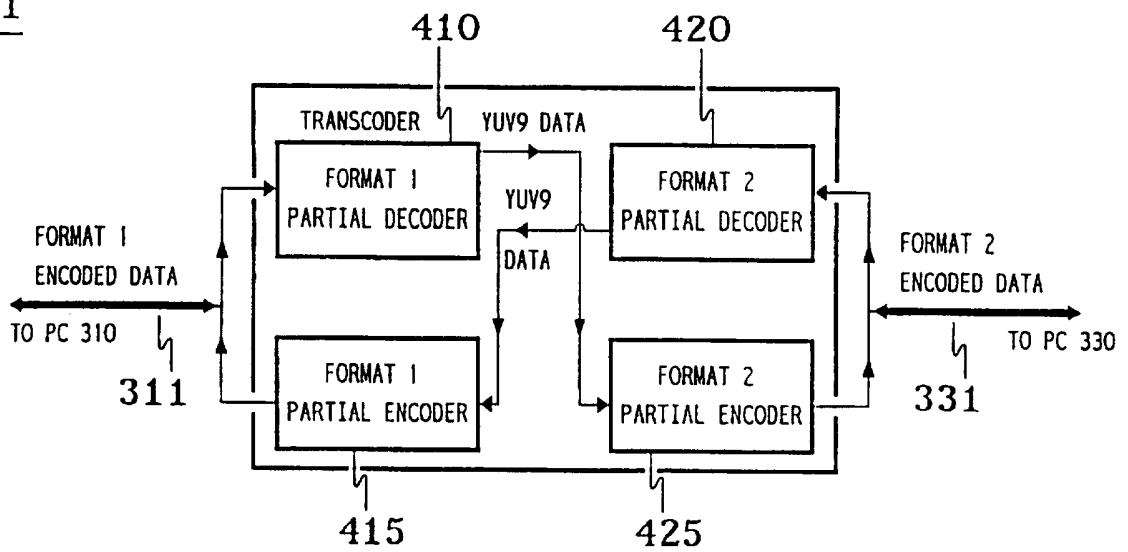

FIG. 5

500

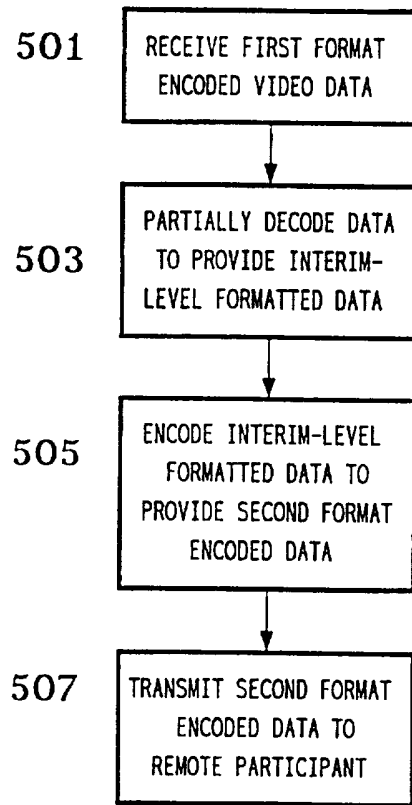
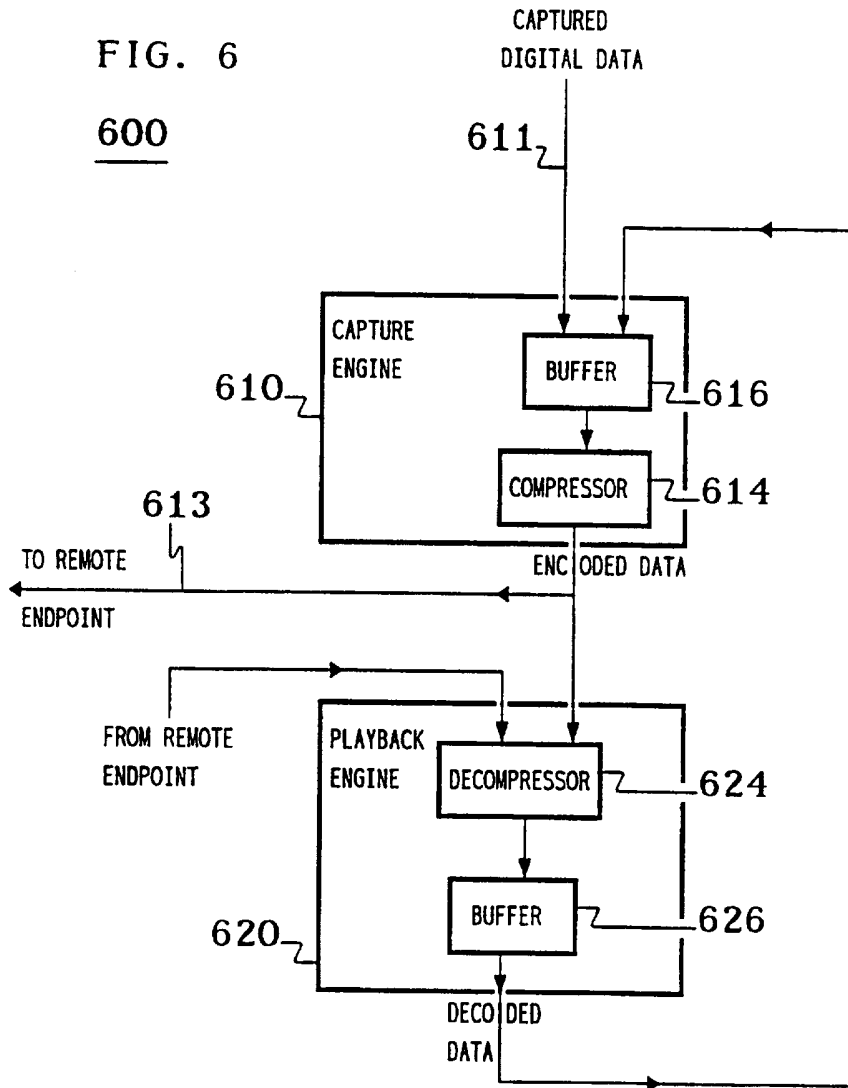

FIG. 6

600



INTERNATIONAL SEARCH REPORT

International application No.
PCT/US97/07213

A. CLASSIFICATION OF SUBJECT MATTER IPC(6) :G06K 9/36; H04N 5/78; H03M 7/40 US CL :382/232, 240; 386/81; 341/67 According to International Patent Classification (IPC) or to both national classification and IPC		
B. FIELDS SEARCHED Minimum documentation searched (classification system followed by classification symbols) U.S. : 382/232, 240; 386/81; 341/67 Documentation searched other than minimum documentation to the extent that such documents are included in the fields searched NONE Electronic data base consulted during the international search (name of data base and, where practicable, search terms used) APS		
C. DOCUMENTS CONSIDERED TO BE RELEVANT		
Category*	Citation of document, with indication, where appropriate, of the relevant passages	Relevant to claim No.
X, P ---- Y	US, A, 5,589,993 (NAIMPALLY) 31 December 1996, col. 12, lines 58-61; col. 13, lines 5-11	1-5, 8-12, 22-26 and 29 ----- 6-7, 13-21 and 27-28
Y	US, A, 5,220,325 (ACKLAND ET AL.) 15 June 1993, col. 4, lines 60-63; col. 8, lines 20-24	6-7, 13-21 and 27-28
<input type="checkbox"/> Further documents are listed in the continuation of Box C. <input type="checkbox"/> See patent family annex.		
* Special categories of cited documents: *A* document defining the general state of the art which is not considered to be of particular relevance *E* earlier document published on or after the international filing date *L* document which may throw doubts on priority claim(s) or which is cited to establish the publication date of another citation or other special reason (as specified) *O* document referring to an oral disclosure, use, exhibition or other means *P* document published prior to the international filing date but later than the priority date claimed *T* later document published after the international filing date or priority date and not in conflict with the application but cited to understand the principle or theory underlying the invention *X* document of particular relevance; the claimed invention cannot be considered novel or cannot be considered to involve an inventive step when the document is taken alone *Y* document of particular relevance; the claimed invention cannot be considered to involve an inventive step when the document is combined with one or more other such documents, such combination being obvious to a person skilled in the art *&* document member of the same patent family		
Date of the actual completion of the international search 21 JUNE 1997		Date of mailing of the international search report 29 JUL 1997
Name and mailing address of the ISA/US Commissioner of Patents and Trademarks Box PCT Washington, D.C. 20231 Facsimile No. (703) 305-3230		Authorized officer ANH HONG DO <i>Joni Hall</i> Telephone No. (703) 308-6720