



- (51) International Patent Classification:
B63C 9/02 (2006.01)
- (21) International Application Number:
PCT/IN2014/000090
- (22) International Filing Date:
12 February 2014 (12.02.2014)
- (25) Filing Language: English
- (26) Publication Language: English
- (30) Priority Data:
435/MUM/2013 13 February 2013 (13.02.2013) IN
- (72) Inventors; and
- (71) Applicants : GUPTA, Ravi [IN/IN]; 473-E, 1st Floor, Hardev Puri, Gautam Nagar, New delhi 110049 (IN). PATEL, Yogendra Singh [IN/IN]; Ugly Road, VPO Keolari, Dist., Seoni, Jabalpur Madhya Pradhesh (IN).
- (74) Agent: CHUG, Neha; Premier Registration Service, 8/1 Rajinder Nagar, New Delhi 110060 (IN).
- (81) Designated States (unless otherwise indicated, for every kind of national protection available): AE, AG, AL, AM, AO, AT, AU, AZ, BA, BB, BG, BH, BN, BR, BW, BY,

BZ, CA, CH, CL, CN, CO, CR, CU, CZ, DE, DK, DM, DO, DZ, EC, EE, EG, ES, FI, GB, GD, GE, GH, GM, GT, HN, HR, HU, ID, IL, IN, IR, IS, JP, KE, KG, KN, KP, KR, KZ, LA, LC, LK, LR, LS, LT, LU, LY, MA, MD, ME, MG, MK, MN, MW, MX, MY, MZ, NA, NG, NI, NO, NZ, OM, PA, PE, PG, PH, PL, PT, QA, RO, RS, RU, RW, SA, SC, SD, SE, SG, SK, SL, SM, ST, SV, SY, TH, TJ, TM, TN, TR, TT, TZ, UA, UG, US, UZ, VC, VN, ZA, ZM, ZW.

(84) Designated States (unless otherwise indicated, for every kind of regional protection available): ARIPO (BW, GH, GM, KE, LR, LS, MW, MZ, NA, RW, SD, SL, SZ, TZ, UG, ZM, ZW), Eurasian (AM, AZ, BY, KG, KZ, RU, TJ, TM), European (AL, AT, BE, BG, CH, CY, CZ, DE, DK, EE, ES, FI, FR, GB, GR, HR, HU, IE, IS, IT, LT, LU, LV, MC, MK, MT, NL, NO, PL, PT, RO, RS, SE, SI, SK, SM, TR), OAPI (BF, BJ, CF, CG, CI, CM, GA, GN, GQ, GW, KM, ML, MR, NE, SN, TD, TG).

Published:
— without international search report and to be republished upon receipt of that report (Rule 48.2(g))

(54) Title: ROUNDED LIFE BOAT

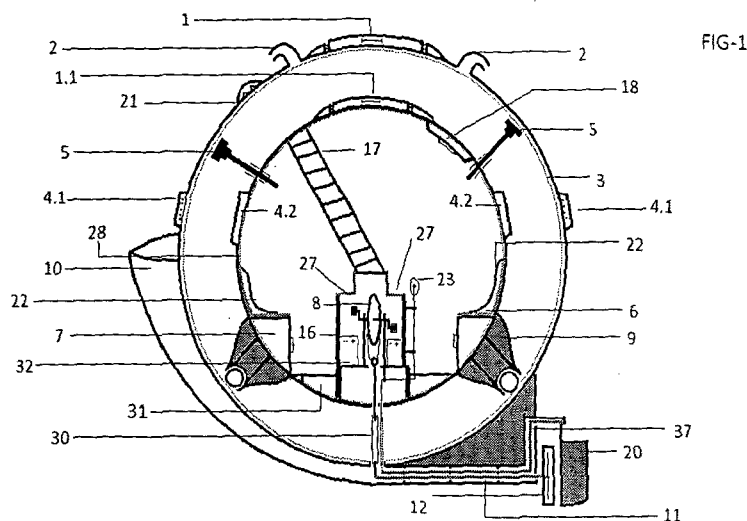

(57) Abstract: The invention provides a rounded life boat which can neither sink nor topple during any type of sea or river emergency. It contains oxygen cylinders, water and food for 'x' persons. It can be operated by paddle. It contains a propulsion system. The walls of the inner and outer ball structures are made of fiber glass or light metal materials. The outer ball structure of the invention protects the persons sitting inside the inner ball structure from any type of sea impacts. The inner and outer ball structures are independent from each other in order to prevent the inner ball structure from any type of sea impact. The inner and outer ball structures are separated from bearings made of steel. This invention is capable of carrying all essential material during the extreme sea emergency.



WO 2014/125503 A2

ROUNDED LIFE BOAT

FIELD OF THE INVENTION

The present invention relates to the field of Life Boats.

More particularly, the invention relates to the field of life boat during emergency.

Even more particularly, the invention provides a rounded life boat which can neither
5 sink nor topple even in extreme conditions.

BACKGROUND OF THE INVENTION

Life boats are used for the purposes of rescue during emergency situation on high seas or river. There are already various kinds of life boats available in the maritime industries which are used for the purposes of saving life in sea during emergency.

10 There have been much evident ship drowning in high seas and rivers and passengers were not saved due to lack of life boats, either the life boat are less in number or the ship does not have enough space to accommodate more number of life boats. Ships also do not accommodate life boats due to the shape of the life boat and its space consuming capacity.

15 Although ships comprises of life boats in enough numbers but some life boats does not survive in high waves in seas and rivers. Sea having high waves drowns the life boat due to its small and open structure and hence results into the drowning of the persons on the life boat. Some life boats are not able to survive for more days because either they are based on air pump which loses its air eventually. Life boats are
20 normally either made of tube like structure or in shape of small boats to carry 4 to 5 persons. Normally the ship are able to accommodate such life boats which are small in size and consumes less space but that again results into carrying less number of persons with high amount of risk. Some life boats does not have capacity to store

water and food for a longer period because either they are open in structure which make a way for sea water to enter and spoil the reserved food or water.

Therefore it is very important to provide solutions which can solve the above problems in innovative manner. The present invention aims to provide solution for 5 the above mentioned problems, and provide a better secured, efficient, cost effective and less space consuming life boat for the maritime security in high seas and rivers.

Reference may be made to Application number KR20120011204 20120203, by AHN CHANG MYEON et. al., dated 13.08.2013, titled "LIFEBOAT". In this invention a lifeboat is provided to connect an opening on the top of cover part to a lift suit by 10 using a connection device, thereby stably connecting the life suit with the lift boat even in a case where the life boat is shaken by wave. CONSTITUTION: A lifeboat includes a hull, a cover part, a connection device, and a slope guide plate. The cover part covers the top of the hull, has an opening that is connected with a life suit so that an escapee can enter a cabin inside the cover part. The connection device connects the 15 life suit to the opening. The slope guide plate is installed at the lower portion of opening inside the cover part in order to reduce the falling impact of escapee.

Reference may also be made to Application number KR20130068292 20130614, by KIM JONG MOON, dated 29.08.2013, titled "LIFEBOAT FOR RADIO CONTROL". This invention relates to a remote-controlled boat with a life ring is 20 provided to reduce the volume of a boat body by remote-controlling the boat, thereby facilitating the handling and transportation of the boat to quickly rescue drowning people. CONSTITUTION: A remote-controlled boat comprises a heat sensor, a life ring, an air bag module, an electric reel, a housing, and an inflator. The heat sensor is installed in a stem of a boat body. The heat sensor detects the body temperature of 25 drowning people and transmits the detected signal to a control part by which a rudder makes the boat body face the drowning people. The life ring is loaded on a groove formed on a deck of the boat body. The air bag module is arranged on the deck of the

boat body and deploys an air bag according to the control signal of the control part. The electric reel is arranged in a stern of the boat body and winds a rescuing wire. The housing is installed on the deck of the boat body and has a discharge port for guiding the deployed air bag. The inflator is installed inside the discharge port of the
5 housing and supplies gas to the air bag.

Further reference may be made to Application number TW20130203032U 20130208, by CHIU CHING-HUA et. al., dated 21.06.2013, titled "Remote life-saving apparatus". This invention relates to a remote life-saving apparatus includes a life-saving boat and a remote. A propelling device is mounted under the bottom of the
10 life-saving boat. A controlling module and a power device are mounted inside the life-saving boat. The remote can remote-operate the controlling module of the life-saving boat by electric wave, and changes the moving direction of the life-saving boat. In a bad weather condition or a critical situation, a lifeguard is able to remote-operate the remote for saving a drowning people. Reducing the risk that the lifeguard
15 dies for saving people in a bad saving-situation.

Reference may be made to Application number KR20130028983 20130319, by LEE JUN GU, dated 15.07.2013, titled "SAFETY ENHANCED TRANSPARENCY BOAT". This invention relates to a transparent boat with improved safety is provided to improve safety without additional life jackets by providing a boat body with a
20 buoyancy function. CONSTITUTION: A transparent boat with improved safety comprises a boat body, a reinforcement support, first and second cylindrical buoyancy members made of a fiber reinforced plastic (FRP), extended portions, bent portions, hanging portions, and fixed extended portions. The boat body is transparently formed using polycarbonate. The reinforcement support is composed of
25 an aluminum pipe and is fixed to the inner wall surface of the top end of the boat body using fixing bolts. One end of the first buoyancy member is bolted to the reinforcement support, and the other end thereof has a shape corresponding to the

bow of the boat body to be fitted to the bow of the boat body. One end of the second buoyancy member is bolted to the reinforcement support, and the other end thereof has a shape corresponding to the stern of the boat body to be fitted to the stern of the boat body. The extended portions are horizontally extended from the ends of the first 5 and second buoyancy members. The bent portions are vertically bent from the ends of the extended portions to form a space, and the bow or stern of the boat body is inserted into the space.

Reference may be made to Application number KR20110142524 20111226, by JOO GWANG WOOK, dated 04.07.2013, titled "ALL WEATHER SALVAGE BOAT".

10 In this invention an all-weather salvage boat is provided to rapidly and safely save a life even in a bad weather. CONSTITUTION: An all-weather salvage boat comprises a hull, an entrance door, and an emergency door. The hull is formed in a cylindrical shape and has multiple windows, ballast, and propellers. The entrance door is installed on one side of the hull and has a foothold. The emergency door is installed 15 on the top of the hull to enable victims to enter.

Reference may also be made to Application number CN20122438891U 20120831, by ZHANG MIN, dated 27.03.2013, titled "Life raft manual desalting device". This invention relates to a life raft manual desalting device comprises a power mechanism for pumping sea water, a desalting mechanism connected with the power mechanism 20 and a water storage tank of drinkable water. The life raft manual desalting device is characterized in that the power mechanism comprises a reciprocating pump with an absorb pipe and a discharge pipe. An absorb mouth of the absorb pipe is inserted into the sea water. The discharge pipe is connected with a water inlet mouth of a reverse osmosis filter film through a channel. A piston of the reciprocating pump is 25 connected with a plunger rod. The other end of the plunger rod is in rotating connection with a connecting rod. The other end of the connecting rod is connected with a round plate with a handle in a rotating mode. When the round plate rotates in a

reciprocating mode, the connecting rod is in linear motion under the action of a guide sleeve, the plunger rod and the piston are driven to move in a linear and reciprocating mode, and liquid discharge of the reciprocating pump is achieved. Due to the manual operation, the life raft manual desalting device is capable of being used at any time
5 without limits of places, being convenient to use, small in size, light in weight, free from preparation of the drinkable water on a lift boat and a lift raft, reducing cost, being used at any time, protecting environment and saving energy, desalting water and at the same time eliminating poisonous materials, adding mineral substances needed by the human body, enabling the sea water to be drunk directly after desalting
10 and being safe and clean.

Another reference may be made to Application number CN20102536544U 20100919, by WEIXIANG SHAO et. al., dated 13.04.2011, titled "Deposition boat". The utility model relates to a deposition boat special for low temperature oxide (LTO) film processing, which can guarantee that gas enters a boat body and can also
15 improve the strength of the boat body. The deposition boat comprises an upper cover and a lower cover of which the external contours are semi-cylindrical, wherein a plurality of round through holes are uniformly distributed on the cylindrical faces of the upper cover and the lower cover. In the deposition boat, the traditional rectangular slots are changed into the round through holes, so that the uniformity of the thickness
20 of an LTO film is guaranteed; and the area of the holes on the boat is relatively reduced, so that the strength of the boat is improved and then the service life of the boat is prolonged.

Reference may be made to Application number CN20101119227 20100308, by GAOCAI WANG, dated 21.09.2011, titled "Waterborne life-saving apparatus with
25 air-storing airbag ring". The invention discloses a waterborne life-saving apparatus with an air-storing airbag ring. The water life-saving apparatus is characterized in that a round ring-shaped 'air-storing airbag ring' member and a spherical ring-shaped

'protective airbag ring' member are integrally connected; a flat spring is used for supporting the inner wall of the 'protective airbag ring' and is in rigid connection; and 'waterproof trousers', a 'neck strap' and a 'turning cover' are used for closed connection of upper and lower ends so as to form a closed spherical ring airbag bin
5 type life-saving protection device. When the apparatus provided by the invention is in standby, air is stored in a hollow capsule space on the round ring-shaped inner side of the 'air-storing airbag ring'; when the apparatus provided by the invention is in use, the stored air is input into the 'protective airbag ring' so that the 'protective airbag ring' expands and rises; in escape, the gravity of a human body acts on the lower end
10 of the inner side of the 'life-saving device', and the upper end side of the life-saving device is a spherical ring-shaped light airbag component floating on the water surface like an airbag gyro floating in water; and the water life-saving apparatus can be used for effectively overcoming the vortex siphon harm generated by the boat sinking, and a comprehensive shielding effect on escapers can be realized.

15 Reference may be made to Application number CN2007141448 20070530, by GUOCHENG ZHANG, dated 03.12.2008, titled "Life saving submarine boat". This invention relates to a lifesaving submarine, which is characterized in that: the lifesaving submarine has two lifesaving channels, which are respectively provided with an open inner door; the open inner doors are communicated with the lifesaving
20 submarine; every lifesaving channel is provided with an open outer door and a round outlet; the open outer doors and the round outlets can be communicated with a wrecked submarine; an upper corner and a lower corner of a rail lifesaving channel are respectively provided with a rail-type navigation channel, and the rail-type navigation channels are slowly pushed out by a motor device so as to be gradually
25 connected with one connection port of the wrecked submarine; a rubber lifesaving channel can be folded; a frame in an opening of the rubber lifesaving channel is connected with a crane through ropes; when the crane raises the rubber lifesaving channel to a certain height, the rubber lifesaving channel is gradually connected with

another connection port of the wrecked submarine; the outer doors of the lifesaving channels are respectively provided with an ultrasonic distance measuring device; outer connecting parts of the lifesaving channels are provided with magnetic rubber gaskets, and the magnetic rubber gaskets can be magnetized and demagnetized
5 before/after a lifesaving process. The invention aims to provide the lifesaving submarine, so as to eliminate defects without the lifesaving submarine.

Further reference may be made to Application number CN20062125558U 20061129, by ZHOU BAOSHENG CHENG, dated 07.11.2007, titled "Propeller of circular loom shuttle". The utility model belongs to the field of mechanical skill, in particular to a
10 thruster for a round loom shuttle boat. A short shaft is pin jointed on a pushing ram. The extended end of the short shaft is rotatably linked with a cover body which is fixed with a box body. A rotatable friction axle and a pushing axle are arranged in the box body in a parallel way. The axial core wire of the pushing axle and the axial core wire of the short shaft are on the same line. The friction axle and the pushing axle are
15 pin jointed with a pair of main and auxiliary gears that are mutually meshed with each other and arranged in the box body. The friction axle and the extended part of the pushing axle that is away from the box body are respectively pin jointed with a friction wheel and a pushing wheel. The thruster is arranged with a pullback spring. The friction wheel is addressed on a friction ring of the round loom under the action
20 of the pulling force of the pullback spring. The utility model has the advantages of small volume, simple structure, low noise, long service life and low cost, which is suitable to a swing stem type plastic round loom and plastic round looms with other structures.

Further reference may be made to Application number CN20032128723U 20031224,
25 by LUO YI, dated 22.12.2004, titled "A polyurethane boat fender". The utility model relates to a polyurethane protecting shipboard for buffering and shock-absorbing between a ship and a wharf, comprising a main protecting shipboard body shaped like

a long-strip and a pre-buried fastener in the bottom of the protecting shipboard body, which is characterized in that the main protecting shipboard body is designed in hollow with more than one connecting through holes arranged; chamfering angles are arranged at the two top ends in a length direction, while the pre-buried fastener is coated in the bottom of the protecting shipboard body. The main protecting shipboard body is made from polymer for polyurethane materials. The utility model has the advantages of reasonable structure, easy manufacture and good stress dispersion in a practical use. The compressive deformation of the hollow round of the main protecting shipboard body can reach at a maximum of 60 percent with a high absorbing energy and a spring rate reaching at 100 percent. In the mean time, since the polymer for polyurethane materials are adapted to the protecting shipboard of the utility model, the service life is extended with good performance and reduced costs.

Another reference may be made to Application number CN2003241381U 20030428, by HAN SHOUGUO, dated 07.07.2004, titled "Environmental protection overall plastic agricultural boat". The utility model relates to an agricultural boat. An environmental protection overall plastic agricultural boat has a hull which is made of linear low density modified polyethylene and formed integrally by spinning molding technique. The hull is provided with a plurality of partition boards, a stern is provided with a poop-deck, and the tail end of the poop deck is provided with a wall board for hanging an outboard motor. Gunnels amidships are respectively provided with a plurality of paddle sockets, a cabin bottom is provided with bilge grates, and a bow is provided with a bow deck. The utility model is characterized in that: a round steel is buried in advance in a midship keel. Four vertical double knuckle lines are arranged on the two outboards of the hull. The utility model has the advantages that: the environmental protection overall plastic agricultural boat is high in strength, long in service life, shock and corrosion proof, simple, light, flexible, economical and practical, while various prior agricultural boats of various materials do not have the advantages.

Reference may be made to Application number US20020318429 20021212, by KELLER ROGENALD J, dated 29.05.2003, titled "Boat with swing seating". This invention relates to a boat having chairs which are swingably mounted in transversely spaced relation at opposite sidewalls of the boat. The boat includes a lower deck and
5 a vertically spaced upper deck, the latter extending generally in a single plane and generally substantially continuously across the boat's interior at the level of the upper surface of the sidewalls of the boat, to effectively shed substantially all high wave water. Each of the chairs has a supporting pedestal mounted at or above the top deck along the upper surface of both boat sidewalls, so the swinging seat of the chair can
10 be swung outside the boat sidewalls.; Each chair is pivotally mounted upon the upper surface of a swinging frame which encircles the chair's pedestal, and its axis of pivot relative to the frame is disposed at the front of the chair, which provides a force opposing the force vectors presented by high waves, and facilitates movement of the chair for greater comfort and safety. Side rails are mounted upon and extend
15 upwardly from each chair pedestal and along each sidewall.

Reference may be made to Application number GBD191223645 19121016, by ROSE GEORGE FITZHARDINGE, dated 16.01.1914, titled "Improvements in Life-saving Appliances". This invention relates to a Life -boats, which comprise improvements in oar propelled life-boats of the enclosed type. The life-boat is formed in two
20 sections constituting a chamber capable of being divided into a number of watertight compartments. A conning - tower is fitted having ventilators closed by shutters in a water-tight manner from within the boat, and also portholes. Hooks carry a seaanchor, as shown, and eyebolts are fitted for lifting the boat on to the deck of a ship. Sliding doors are provided on the section, and a door is also fitted to the top of the conning-
25 tower. Rails having rollers are secured to the bottom of the bottom to facilitate passage across the deck. The boat is propelled by oars passing through water-tight ball-and-socket joints in the hull and secured when not in use to the seats. Water-tight casings are fitted beneath the athwartship seats, and in addition a chamber is

constructed round the sides of the boat to increase the buoyancy. A telescopic mast, lockers, steering-gear, &c. are also provided. In a modified form, the boat is cylindrical floating with its axis vertical.

Reference may be made to Application number CN20132197364U 20130418, by
5 WANG CHONGGAO, dated 25.09.2013, titled "Portable anti-impact sea life boat".
The utility model discloses a production technology of a portable anti-impact sea life boat. The boat mainly comprises a boat shell, a pressurized-water cabin partition plate, a boat deck, a front wind shield, a rear wind shield, middle push-pull wind shields and a movable plate, wherein the pressurized-water cabin partition plate is
10 arranged inside the boat shell; the boat deck is arranged on the pressurized-water cabin partition plate; the front wind shield is arranged inside a groove at the head part of the boat shell; the rear wind shield is arranged inside the groove at the tail part of the boat shell; tracks are arranged on two side frames at the rear part of the boat shell; and the middle push-pull wind shields are arranged on the tracks. Thus, the middle
15 push-pull wind shields can move on the tracks; and pass-in and pass-out of the personnel are facilitated. The boat has the characteristics of small resistance, light weight, impact resistance, storm resistance, corrosion resistance and aging resistance, and is widely applied to salvage, fishing on the sea, playing on the sea, marine sports, military activities and the like.

11

20 Reference may be made to Application number KR20110139915 20111222, by
JANG MIN WOOK, dated 02.07.2013, titled "LIFE BOAT CONNECTING UNIT
AND LIFE BOAT DAVIT HAVING THE SAME". This invention relates to a lifeboat davit connection unit and a lifeboat davit having this connection unit are provided to fix a lifeboat stably by dispersing a load to the top surfaces of the first
25 and the second connection parts. CONSTITUTION: A lifeboat davit connection unit comprises multiple first and second connection parts. Each first connection part is installed in a lifeboat and has a housing space (S) with an opened portion. The opened

portions of the first connection parts are separated from each other and face each other. The second connection parts are connected to ascending and descending members for ascending and descending the lifeboat and are inserted into the housing spaces of the first connection parts to support the lifeboat.

5 Further reference may be made to United States Patent number 7,704,112, by Kim, dated 27.04.2010, titled "Portable personal self-operating life tube". This invention relates to a portable personal self-operating life tube is disclosed, in which when a user is drowned in water due to a marine disaster or a fire and sinking of a ship, it automatically operates, so the user can save his life by just wearing the tube, and the
10 tube is able to keep a user's a body temperature until a rescue comes after the tube is expanded along with the above features, and a life tube can be easily used without a particular care by improving the problems found in a conventional art in which a user feels bad when wearing a life tube since a conventional life equipment is not customized, and it is not portable and is not easy to use.

15 Reference may be made to United States Patent number 6,904,864. By Re et al., dated 14.06.2005, titled "Controlled lifeboat deployer". This invention relates to a control system to control the descent of a seafaring vessel, such as a lifeboat, into water is disclosed herein. The control system and an accompanying method, control the descent speed of the seafaring vessel to minimize the possibility of setback after
20 splashdown, and thus increase the probability of a safe and orderly launch.

Reference may be made to United States Patent number 6,718,903 by Moise, II, et. al., dated 13.04.2004, titled "Life boat". An improved lift boat includes a hull, a plurality of legs (preferably three), a plurality of pads, one pad attached to each leg, and a jacking mechanism for moving each upward and downward. Recesses in the hull
25 receive the pads when the lift boat is underway. Preferably, the total bottom surface area of the pads is at least 30% of the surface area of the deck of the lift boat.

Preferably, the total bottom surface area of the pads is large enough such that, when the boat is loaded to capacity and is jacked up, the pads exert pressure of less than 7 p.s.i. on the sea floor. Preferably, the pads are partially recessed into the hull and extend laterally outward from the hull when the boat is underway to provide
5 increased stability to the lift boat when it is underway.

Reference may also be made to United States Patent number 6,547,189 by Raboin, et al., dated 15.04.2003, titled "Inflatable vessel and method". This invention relates to aninflatable module comprising a structural core and an inflatable shell, wherein the inflatable shell is sealingly attached to the structural core. In its launch or pre-
10 deployed configuration, the wall thickness of the inflatable shell is collapsed by vacuum. Also in this configuration, the inflatable shell is collapsed and efficiently folded around the structural core. Upon deployment, the wall thickness of the inflatable shell is inflated; whereby the inflatable shell itself, is thereby inflated around the structural core, defining therein a large enclosed volume. A plurality of
15 removable shelves is arranged interior to the structural core in the launch configuration. The structural core also includes at least one longeron that, in conjunction with the shelves, primarily constitutes the rigid, strong and lightweight load-bearing structure of the module during launch. The removable shelves are detachable from their arrangement in the launch configuration so that, when the
20 module is in its deployed configuration and launch loads no longer exist, the shelves can be rearranged to provide a module interior arrangement suitable for human habitation and work. In the preferred embodiment, to provide efficiency in structural load paths and attachments, the shape of the inflatable shell is a cylinder with semi-toroidal ends.

25 Reference may also be made to United States Patent number 6,739,278 by Callahan, dated 25.05.2005, titled "Folding rigid-bottom boat". This invention relates to a folding rigid boat for routine and emergency use by occupants as an auxiliary

watercraft and including complementary rigid bow and rigid stern sections joined together along respective mating edges to form a hull, complementary rigid hinge elements cooperating together to form a centrally-disposed joint pivotally connecting the bow and stern sections along a port-to-starboard axis in vertically spaced-apart
5 relation to the bottom of the hull for permitting the bow and stern sections to be folded onto themselves into a storage configuration and away from each other along the joint into an unfolded use configuration. Flexible topsides are secured to the hull along at least port and starboard sides of the hull for providing an upwardly-extending freeboard to the hull when the boat is in the unfolded use configuration.
10 The topsides are unconnected to and independent of the rigid hinge elements. Waterproofing is carried by the bow and stern sections and is unconnected to and independent of the rigid hinge elements for preventing water leakage through centrally-disposed joint when in the boat is in the unfolded use configuration.

Reference may be made to United States Patent number 6,546,885 by Francke, dated
15 15.04.2003, titled "Collapsible catamaran". This invention relates to a catamaran type water craft having two tandem pairs of scissors-like folding mechanisms disposed between and pivotally connecting to the opposing upright surfaces of adjacent, juxtaposed hulls. The folding mechanisms comprise two pairs of overlapped cross-linked beams joined about central pivot joints. A pair of cross-linked overlapped
20 forward bow beams can also be provided, arranged so as to rise at an increasing angle to the water craft as the water craft collapses. When the boat is collapsed, the cross-linked beams fold like closing scissors to bring the opposing hulls laterally together, and the bow beams are drawn together, allowing the catamaran to fold to a width that can be transported by a truck or placed in a marina docking slip with the mast in its
25 upright position. A mast is located in the pivot structure of the forward pair of crossed overlapped links.

Reference may also be made to United States Patent number 6,870,795 by Bouyoucos, et al., dated 22.03.2005, titled "Acoustic source array system module for underwater operation which can be installed on a motorized boat". This invention relates to a small boat or launch such as a motorized reinforced hull inflatable boat 5 provides a platform for an acoustic source array of airguns. The array is made up as a ladder structure in which the airguns are disposed horizontally between vertical support and umbilical lines, preferably with their discharge ports in laterally offset or staggered relationship to minimize undesirable interactions between the acoustic transmissions released into the water by the sources and to help maximize the 10 acoustic output of the array for a given array length. A structure stows the array on the boat for transport when the array is not deployed for use. If desired, the stowed array may be substantially enclosed by the hull of the boat. The stowage structure is preferable defined by a track or rails on the top of the deck. Umbilical cables attached to the array are translated, as by being wound on a drum and unwound therefrom, to 15 deploy or retrieve the array over the stern of the boat. The umbilicals provide power (compressed air to the airguns and control signals for timed actuation of the guns). The array may be part of a module which includes a winch for winding and unwinding the umbilicals to retrieve and deploy the array. The array system also includes a compressor for supplying compressed air to the airguns of the array.

20 Reference may be made to United States Patent number 6,367,404 by Callahan, dated 09.04.2002, titled "Folding rigid-inflatable boat". This invention relates to a folding rigid-inflatable boat for routine and emergency use by occupants as an auxiliary watercraft. The floating rigid-inflatable boat includes a hull having complementary rigid bow and rigid stern sections joined together along common, centrally disposed 25 joint edges, a hinge element extending laterally from port to starboard along the centrally disposed joint edges and pivotally connecting the bow and stern sections together for permitting the bow and stern sections to be folded onto themselves into a storage configuration and into an unfolded use configuration; and inflatable topsides

secured to the hull and extending around the periphery of the hull for providing an upwardly extending freeboard and for further providing rigidity to the hull when the boat is in the unfolded use configuration.

Further reference may be made to United States Patent number 6,361,061 by Lea, dated 26.03.2002, titled "Boat protection system". This invention relates to a boat protection system for protecting the body of a boat during transporting upon a conventional boat trailer. The boat protection system includes a front guard, a bottom guard attachable to the front guard, a first side guard attachable to the front guard, and a second side guard attachable to the front side guard. The front guard is comprised of a front portion, a front opening within the front portion for receiving a winch, and a pair of side portions. The front guard is attached to the front portion of the frame with conventional fasteners. The bottom guard is attached to a lower lip of the front guard. The front guard, bottom guard, and side guards protect the lower body of the boat carried upon the trailer from debris elevated by a motor vehicle pulling the trailer.

Reference may be made to United States Patent number 6,659,815 by Motsenbocker, dated 09.12.2003, titled "Efficient motors and controls for watercraft". This invention relates to a Electronic control systems, devices and algorithms are described for improving boat efficiency, safety and convenience, particularly for electric motor powered boats. The overall efficiency of electric boat propulsion is improved by matching the needs of the propeller with the magnetic field requirements of the motor. Efficiency also is improved by limiting slip at different boat speeds. Rapid and fully electronic propeller shut off systems also are described for enhancing public acceptance of electric boats and more convenient cruise control systems are described for improving public acceptance of the boating experience.

Reference may also be made to United States Patent number 6,178,911 by Hemphill, et al., dated 30.01.2001, titled "Automatically inflatable boat". This invention relates

to an automatically inflatable boat including at least two separate compartments which are connected to one another by an intercommunicating valve which can be opened to connect adjacent compartments or closed to isolate adjacent compartments. The inflatable boat is provided with a gas pump permanently mounted on the boat
5 and in fluid communication with a connection for receiving pressurized gas of at least one of the inflatable compartments. The pump can be actuated in order to automatically inflate the inflatable compartments of the boat to a preset pressure. Also shown is an inflatable enclosure which can be deflated and inflated and to house an adult and a commode to provide privacy.

10 Another reference may be made to United States Patent number 6,006,687 by Hillman, et al., dated 28.12.1999, titled "Modular floating boat lift". This invention relates to a floating boat lift capable of accommodating a wide variety of V-hulled boats. The boat lift is comprised of docking members, a bow stop that protects the hull of the boat, a stern segment and at least one intermediate segment. The stern
15 segment and intermediate segment contain a channel with rollers that assist in conveying the boat over the boat lift and supporting the boat when docked. The rollers have different height configurations and can be positioned in different trays in the channel so that they can be used with boats that have different dead rise angles.

Further reference may be made to United States Patent number 5,803,003 by Vickers,
20 dated 08.09.1998, titled "Rotary boat lift". This invention relates to a Boat lift apparatus comprises vertically oriented upper and lower box beam track members mounted adjacent a dock for the upper track member to extend above the deck of the dock. The upper track member is rotatable relative to the lower track member, and the two track members support a boat cradle for vertical displacement therealong
25 between a lower position in which the cradle is partially submerged in water for loading and unloading a boat thereon and an upper position in which the cradle is on the upper track member and pivotal therewith to overlie the deck. The cradle is

provided with upper and lower bearing arrangements by which the cradle is supported for vertical displacement along the track members, and the lower bearing arrangement is comprised of opposed pairs of bearing blocks having planar surfaces for sliding engagement with the track members, and the upper bearing arrangement is
5 comprised of opposed pairs of bearing rolls in rolling engagement with the track members.

Reference may be made to United States Patent number 5,711,808 by Yang, et al., dated 27.01.1998, titled "Boat for vertical diffusion furnace". This invention relates to a boat for a vertical diffusion furnace has an upper disk and a lower disk spaced
10 parallel from each other by a predetermined distance. A pair of first bars having a plurality of wafer holding slotsface each other along a first center plane extending along a diameter of the upper and lower disks, and connect the upper and lower disks. A pair of second bars also connect the upper and lower disks, and are positioned at a predetermined angle with respect to a second center plane orthogonal to the first
15 center plane. The second bars have a plurality of slots corresponding to the slots of the first bars. A pair of first auxiliary bars are installed adjacent to the pair of first bars to also connect the upper and lower disks. The boat may further have a pair of second auxiliary bars for connecting the upper and lower disks at positions adjacent to the pair of second bars. Also, a pair of horizontal supporting bars connect the first
20 auxiliary bars to the second auxiliary bars. Therefore, thermal deformation of the first bars is markedly reduced, the slip of the wafers out of the slots is prevented, and the life of the *boat* can be longer.

Reference may be made to United States Patent number 5,597,335 by Woodland, dated 28.01.1997, titled "Marine personnel rescue system and apparatus". The present
25 invention provides for an air, sea, or land deployed rapid response, self-propelled, autonomous or semi-autonomous marine vehicle (AMV) possessing a pair of extendible hydraulic cylinders encased in a pneumatic inflation chute, with an ability

to be directed toward, and to autonomously seek out and recover physically restricted persons in peril from an aqueous environment. The AMV uses video, thermal, and audio sensors to actively and autonomously detect persons floating in an aqueous environment, and can be directed to a person or persons in distress on the sea surface
5 through an aircraft, ship, or shore mounted, GPS linked, laser targeting system. The present invention also possesses the ability to provide life support functions, propulsive mobility, and two way real-time radio frequency and satellite based voice, video and data telemetry with the rescue aircraft, ship, or shore based coordination center responsible for deploying, operating, or monitoring the AMV.

10 Reference may be made to United States Patent number 5,517,939 by Harman , et al., dated 21.05.1996, titled "Thermoplastic bottom inflatable boat". This invention relates to a boat formed from a flexible hull bottom and side skirts in the form of tapered inflatable tubes. The side skirts are fastened to the hull bottom by flexible adhesive tape or other continuous flexible mechanical fasteners so that there are no
15 hard fastenings or frames to cause stress concentration in the flexible hull bottom.

Further reference may be made to United States Patent number 5,027,735 by Labrador, dated 02.07.1991, titled "Kasipagan sail boat". What has been created is the fastest sail boat that can act as a tugboat or industrially used to pull a water turbine for the production of electricity or compressed air, as compared to the capabilities of the
20 prior arts of equal size and form. This is attained by the use of water as counterweight contained and locked-in inside an impervious pipe which may be of the same length as the boat, which is attached at the side or preferably under the hulls of a catamaran type boat, or which is attached to each lower side of a mono-hull boat;--by erecting as many large square sails as possible along the longitudinal axis of the boat in an
25 arrangement to form an aggregate dwarf sail to bring down the centroid of the aggregate wind force close to the level of the boat to minimize the overturning moment of the wind upon the boat, thereby maximizing wind contact within the

stability limits of the boat;--by making the hulls vertically thin to minimize resistance thru the water;--by adding a short float booster pipe on top of the main floater pipes, which extends beyond the front and rear ends of the hull to provide extra buoyancy on the sinking side when the boat is tilted too far.

5 Another reference may be made to United States Patent number 4,841,901 by McGlew , et al., dated 27.06.1989, titled "Life boat support structure". This invention relates to a support structure for devices particularly life boats and similar apparatus which is weight operated comprises a plurality of support members, each or some of which may be telescopic which are pivotally interconnected adjacent their
10 associated interconnected ends. Each successive upper one of a pair of such members is pivotal relative to the next adjacent lowermost one about a substantially horizontal axis. The pivoting is controlled by a control mechanism which is operated from a fluid pressure source produced by the weight of the elements upon each other. The control mechanism includes means for controlling the amount of tilt of each upper
15 element relative to an adjacent lower element and for the control of the precise angularity of the two elements relative to each other during the pivotal movement. The construction is such that a *life boat* may be supported in either a lower or an elevated position on a large ship and the individual support members may be articulated relative to each other so as to pivot the boat outwardly away from the
20 vessel or ship in any manner which is desired. Thus if the ship is on an even keel some of the support members may be held without pivoting and merely one or two of them pivoted to lower the boat to a position in which it contacts the water line. In those cases in which it is desired that the boat be swung outwardly a large amount away from the vessel before it is pivoted downwardly then only the lowermost two
25 elements are pivoted relative to each other, for example. The feature of the construction is that the weight of the *life boat* itself will cause operation of the controls for the pivoting and for the control of the positioning of each element relative to each other during the proper lowering of the boat into the water.

Reference may be made to United States Patent number 4,522,144 by Klem, dated 11.06.1985, titled "Life saving system for marine structure". This invention relates to a rescue system for a marine structure such as an offshore drilling rig or production platform includes an enclosed type life boat constructed to be supported on board the
5 marine structure by being releasably suspended over free water from a single point or fulcrum. The fulcrum is located relative to the center of gravity of the life boat such that the latter, in its suspended position, adopts a predetermined slanting orientation which it maintains substantially constant throughout its free fall when released from its suspension.

10 Reference may be made to United States Patent number 4,346,664 by Enzian, Jr., dated 31.08.1982, titled "Lifeboat". This invention relates to a Lifeboat in the general form of a hollow prolate spheroid having a hatchway opening in the upper portion and a weighted keel in the lower portion. The lifeboat comprises a main body having inner and outer skins spaced apart in a parallel relationship and a hollow ballast
15 element extends entirely around the periphery of the inner chamber at the bottom and is divided by transverse walls into a plurality of fresh water compartments which also has a flat upper surface for use as a seat. The ballast element also includes a water compartment beneath the floor at the bottom portion of the inner chamber.

Reference may be made to United States Patent number 4,495,884 by Stark, dated
20 29.01.1985, titled "Boat construction and method". The invention presented herein demonstrates a boat hull and method for providing improved flotation characteristics and stackability for a boat having a high strength-to-weight ratio. The boat is constructed with a pre-formed hull with outwardly extending sides and having cellular flotation logs positioned at spaced intervals thereon whereupon with normal
25 impact to the hull said logs will not experience cellular degradation due to their rigid encapsulation. The preferred method demonstrates a structure comprising a series of rectangular flotation logs positioned athwartship along the inside bottom of the hull.

Between the logs an FRP (fiber reinforced plastic) beam is positioned to absorb and divert shock waves from the logs and to increase the strength of the hull. An FRP layer above the logs completes the encapsulation of the logs and secures them in rigid engagement with the hull. The outwardly extending sides and lack of side flotation
5 members contribute to the compact stackability features of the hull.

Reference may also be made to United States Patent number 4,268,930 by Gillespie, dated 26.05.1981, titled "Inflatable mini boat". This invention relates to a mini boat having a first plurality of elongated gas inflatable cells stacked one upon the other and bonded into a single envelopmental unit which conforms closely to the human body
10 for providing buoyancy thereof. The unit is formed to provide a center of mass below the center of buoyancy for increased boarding ease and stability. A supplementary orally inflatable chamber formed atop the first plurality of cells provides additional freeboard for the boat perimeter. One end of the boat is arcuately configured to permit the user to recline therein, thereby protecting him from the elements and lowering his
15 center of gravity, by means of regularly spaced and separated and vertically aligned interconnections between the first plurality of cells which provide points of easy bending.

Reference may be made to United States Patent number 4,180,882 by Kawasaki, dated 01.01.1980, titled "Lifesaving air boat". This invention relates to a life boat
20 adapted to be thrown out into a body of water from a mother boat for automatically forming a lifesaving air boat as a result of being thrown onto the water. The lifeboat structure includes a source of compressed air in the form of an air bomb which is released when a retaining pin for a control valve supplied for the air bomb is pulled out. The release of the compressed air inflates air tubes constructed and defined to
25 form a floating body or lifeboat. The lifeboat may include air tubes to form an enclosure on the floating body for eliminating the danger of an individual being washed away by rough waters. The resulting floating body or lifeboat is further

defined to be propelled through the water by a manually operated mechanism or wind powered mechanism. The floating structure will readily restore to a normal position even when capsized.

Another reference may be made to APPLICATION NUMBER US20130203310
5 (13368283) BY Newman Paul, DATED 07.02.2012, titled "CONVERTIBLE
EMERGENCY DEVICE". Publication Date 08.08.2013, NOT GRANTED. This
invention relates to a convertible emergency device that includes a waist pack that
includes an interior portion with a first zipper is disposed on the front side of the
interior portion, a pair of straps each that extend from the interior portion that wrap
10 and secure the convertible emergency device around a user's waist and a pair of snaps
that fasten the pair of straps around the user. The device also includes a backpack
portion with a front that includes an inflatable life boat with two sides, a pair of oars
disposed on the sides of the inflatable life boat and a second zipper disposed on the
front portion of the backpack portion that is opened to access a second pull cord to
15 inflate the inflatable life boat. There is also a pair of straps and snaps to attach the
emergency device to a user's vest and inflatable boat.

Reference may be made to APPLICATION NUMBER RU0002479462
(2011139941/11) BY Nastasenko Valentin Alekseevich, DATED 30.09.2011, titled
"MOTOR-DRIVEN LIFE-BOAT". This invention relates to a ship building,
20 particularly, to small boats and rafts, namely to their drives. Proposed motor drive
life-boat comprises guide screw with its shaft engaged via system of gears with
basket. Said basket is provided with passenger seats and secured at suspended radial
rods to allow basket cyclic oscillations on semi axles fitted in bearings rigidly
coupled with boat body through $\pm\alpha$ at pitching. Invention covers the versions of gear
25 wheel system coupling lead screw shaft with basket. EFFECT: simplified drive. 20 cl,
6 dwg

Reference may be made to APPLICATION NUMBER KR101261241 (1020110111085), BY PARK, JI SOON, DATED 28.10.2011, titled "DEBIT DEVICE CAPABLE OF INCLUDING A PROTECTIVE COVER MODULE". This invention relates to a debit device to prevent a debit device and a life boat from being directly exposed to the outside by installing a cover module. CONSTITUTION: A debit device comprises a lifting frame, a hinge unit, a cylinder unit, a fixed cover part, a rotary cover part, an auxiliary cover part, and a protective cover module. The lifting frame is connected to a life boat to launch and return the lift boat. The fixed cover part is connected to the lifting frame. The rotary cover part is hinge-connected to the fixed cover part. The auxiliary cover part is installed on an offshore structure. In a state where the life boat is returned, the fixed cover part, the rotary cover part, and the auxiliary cover part are coupled to form an internal receiving part where a debit device and the life boat are received. When the life boat is moved by the lifting frame, the internal receiving part is opened by the protective cover module.

Further reference may be made to APPLICATION NUMBER CN102785771 (201110124826.5) BY LU MAOGAO, DATED 16.05.2011, titled "LIFE-SAVING AND TRAVELING SUBMARINE FOR CIVIL USE". This invention relates to a life-saving and traveling submarine for civil use, belonging to ships; particularly, the invention relates to multiple reformations of a light speed boat, wherein the whole sealing of the submarine is imitated by a ship hull, and an electric water pump is used as a power; a pump and a dual-suction dual-spray pipeline system are used for finishing the forward, backward, left turn, right turn and ups and downs of the ship hull; the ups and downs of the ship hull are regulated by controlling the amount of the water storage of a storing and draining water tank; the fowler positions of passengers can be hung to improve the comfort; a GPS (Global Position System) or a Dipper system is used for positioning, and a video camera and an outer visual operation ship hull can also be used for opening an airtight door, so that the ship hull can be floated upward, or the passengers can climb up to a guardrail platform for view when a wind

wave is calm. The life-saving and traveling submarine has the advantages that the life-saving and travelling submarine for civil use is capable of sailing under the water with a high speed and is not afraid of the wind wave and flooding to overturn and sink the submarine even if a part of the submarine is located above the water, so that
5 the rescue can be carried out in the weather conditions of strong winds and heavy rains; or the submarine is used for travelling on a sea, a lake and a river or undertaking the special transportation tasks such as picking up students over the river on a windy and rainy day and transporting the goods which is afraid of light and water.

10 Reference may be made to Application number KR101195238 (1020120049280) by KIM, KYEONG TAE, dated 09.05.2012, titled "BOAT FOR SAVING A LIFE CAPABLE OF SMOOTHLY LAUNCHING RESCUE OPERATIONS ON THE SEA". This invention relates to a boat for saving a life to improve the efficiency of rescue operations because operators and rescuers can smoothly get on and off the boat
15 through a support plate. CONSTITUTION: A boat for saving a life comprises an opening and closing part, a support plate, and a ladder. The opening and closing part is formed on a side plate of a hull. The support plate is protruded toward the seawater side through the opening and closing part in multiple stages so that the protruded width can be extended. The ladder is detachably formed in the front end of the boat.

20 Reference may be made to APPLICATION NUMBER KR1020120100370 (1020110019220) BY GO, GI YOUNG et. al., dated 04.03.2011, titled "ANTI-FALLING DEVICE FOR A LIFE BOAT CAPABLE OF PREVENTING A LIFE BOAT FROM BEING FALLEN EVEN IF A CHAIN GETS DAMAGED DUE TO UNEXPECTED IMPACT". NOT GRANTED. In this invention an anti-falling
25 device for a life boat is provided to have firm and long lifespan because a core supporting load is composed by a technora having high tensile force. CONSTITUTION: An anti-falling device for a life boat comprises a core, a sleeve,

and eye protectors. The core is formed by winding a para-aramid fiber of 40-80 thousands at 15-30 times so that the length of a loop can be 1-3m. The cover is formed into a shape of a tube for accommodating core strands to cover the core. The sleeve covers except for shackle eye parts in a state where the cover is partially
5 laminated to form shackle eyes for assembling a shackle in both ends. The eye protectors are added on an inner cover of the shackle eyes.

Reference may be made to APPLICATION NUMBER KR1020120040420 (1020100101828) BY LEE, SEUNG HO, DATED 19.10.2010, titled "LIFE JACKET DETACHABLE AIRBOAT HAVING AIR BOAT AND ATTACHABLE COVER".
10 NOT GRANTED. In this invention a life jacket detachable airboat is provided to reduce risk of a drowning accident due to hypothermia. CONSTITUTION: A life jacket comprises a main body, a air boat mounting unit, a air pump and a cover apply part. The air boat mounting unit comprises an air boat and a pump line. The air boat is spread by the aerial pressurizing to the flat board form. The pump line is used for
15 the aerial pressurizing of the air boat. The air pump is formed in the inner one-side of the main body and is connected to the pump line and injects the air into the air boat. The cover apply part is formed under the air boat mounting unit and is accepted to the inner one-side of the main body. The cover apply part is made of a waterproof material.

20 Further reference may be made to Application number CN101857078 (200910045253.X) by Zhang Guocheng, dated 08.04.2009, titled "Life saving rubber boat". This invention relates to a life saving rubber boat, comprising a rubber boat body, rubber seats, an air charging port, a sealing cork, connecting ropes, an air charging chamber, an air charging motor, a rubber tube and the like. The invention is
25 characterized in that the two ends of the life saving rubber boat are connected with the middle part of the life saving rubber boat; the surface layer of the life saving rubber boat is connected with the sides of the life saving rubber boat; the sides of the

life saving rubber boat are connected with the bottom of the life saving rubber boat; four rubber seats are arranged at the two ends of the life saving rubber boat; four rubber seats are arranged in the middle of the life saving rubber boat; the rubber seats of the life saving rubber boat are fixedly connected with the bottom of the life saving rubber boat; the air charging rubber tube orifice and the sealing cork are arranged at one end of the life saving rubber boat; the air charging rubber tube orifice at one end of the life saving rubber boat is connected with the sealing cork; and the connecting ropes are arranged at the two ends of the life saving rubber boat and are connected with other boats.

10 Further reference may be made to Indian Application Number 3048/CHE/2010 BY ABDUL KADER, DATED 14/10/2010, titled "IN-BUILT LIFE SAVING DEVICE ON BOAT". (NOT GRANTED). "Life saving apparatus on boat" is a unique system which is to make safety in water transport when the boat capsizes all passengers can use the capsized boat as a life saving device. The device attached to the boat namely
15 "life saving apparatus on boat" comprised often both end air tightened PVC pipes (life saving pipes) at the bottom and four numbers of both end air tightened PVC pipes (life saving pipes) on each side walls, GI pipes set that makes able to keep the both end air tightened PVC pipes (life saving pipes) in correct position and safely. The wooden planks paved over the "GI pipe set" helps to stand the passengers over
20 the system. A water proof rexin sheet is placed in between the "both end air tightened PVC pipes (life saving pipes)" and pipe set". A nylon rope is attached around the boat to enable the travellers to catch the same in case of casualty. The length and width of both end air tightened PVC pipes (life saving pipes) are decided in accordance with the passenger's load plus total weight of the boat including this system.

25 Further reference may be made to Indian Application Number 2914/MUM/2011, BY SAURABH K SHARMA, DATED 18/10/2011, titled "LIFE BOAT DESK". (NOT GRANTED). This invention relates to a device is useful as the deck of ship, as well as

a life boat for saving the lives of people on boards is disclosed. The device is an light weight material boat with hucks and guiding bar at the bottom. The hucks are arranged to ramp. By using this device many lives can be saved during marine accidents and search operation of life boat

5 Reference may be made to Indian Application Number 66832, by SOCIETE ZODIAC, DATED 24.02.1959, titled "Improvements in pneumatic life-boats". This invention relates to pneumatic life boats of the automatically inflatable type of which the interior space is divided in to two portions by a partition of pneumatic or rigid materials, one of the said portions being used by personnel for staying under normal
10 conditions and the other being without freeboard, for the embarkation of shipwrecked persons. The portion without freeboard has attached thereto an immersed approach ramp on which the shipwrecked persons can easily gain access to the bottom of the boat which is completely above the water level.

Reference may be made to Indian Application number 60113, by Din Dayal Gupta,
15 dated 04.04.1957, titled "Unsinkable life boats and boats". This invention relates to boats and more particularly life boats. Life boats from essential equipments in a ship and are used in time of danger when the ship is about to sink and the lives of the passengers are thereby endangered. Lifeboats hereto employed are of the usual design provided with oars or an engine for propelling the same. Their design however does
20 not afford any additional factor of safety. Thus in a stormy sea or in the event of which may cause the ship to sink, the life boats are not free from danger.

Reference may be made to Indian Application number 5446, by Frank Forbes Lowndes, dated 24.03.1920, titled "An improved life saving apparatus for boats". This invention relates to improvements in life saving apparatus for boats. The object of
25 this invention is to provide convenient means by which a grip may be obtained by shipwrecked persons to enable them to overturn boats and also enable them to more easily restore to their right positions such overturned boats.

Reference may also be made to Indian Application number 33113 by ING FOOT CORPORATION, dated 23.08.1945, titled "A pneumatic structure such as a life vest, inflatable rubber boat or the like". The present invention relates to pneumatic structures generally of the type embodying a plurality of individually inflatable fluid compartments. The pneumatic structures of the present invention comprises in its broadest aspects two adjacent and individually inflatable fluid compartments separated by one or more fluid tight enclosures.

Reference may be made to Indian Application number 29516, by George Keenan et al., dated 26.04.1943, titled "Improvements in distilling apparatus especially applicable for use in ship's lifeboats". This invention relates to an Apparatus of a compact and simple character for enabling small supplies of fresh water to be distilled is required for many purposes, and is particularly desirable to form part of the equipment of a ship's lifeboat for obtaining fresh water from seawater should the quantity of fresh water normally carried by such boats become exhausted owing to the length of time during which the lifeboat may be afloat before the occupants reach shore, or are picked up.

Reference may be made to Indian Application number 26731 by IVAN RUPERT FLEMING et. al., dated 31.07.1939, titled "Improvements in or relating to hand propelling gear for ship's lifeboats". This invention relates to a type of hand propelling gear which comprises two coupling rods connected to crank discs on a counter shaft at the stern of the boat, which counter shaft drives the propelling shaft, and the coupling rods are reciprocated by hand levers which are oscillated in a vertical plane.

Reference may be made to Indian Application number 2016 by JOHN LEWIS PATTERSON dated 05.02.1915, titled "A combined hand-grip and fender for use on life-lines of life boats and for other purposes". This invention consist of a combined hand grip and fender for use on the life lines of life boats, and is designed to afford a firm hold on the life lines and to protect the hand from being crushed against the side

of the boat when in use for life saving purposes, especially when the boat may be rolling violently in a heavy sea. It is also designed to serve as a fender. For those purposes one or more of such combined hand grips and fenders may be threaded on each bight of the life lines.

5 Reference may be made to Indian Application number 1656 by LEON LA FONTAINE, dated 18.05.1914, titled "Improvements in life boats". This invention relates to a life boat of the type in which a passenger car is suspended within a cylindrical or approximately cylindrical hull or shell, whereby the passenger car is adopted to retain its normal position independent of the rolling or capsizing of the
10 hull or shell of the life boat.

Reference may be made to Indian Application number 15775 by IVAN RUPERT FLEMING, dated 21.05.1929, titled "Improvements in and connected with boats, such as ship's life boats". This invention has reference to boats and more particularly to ships life boats. It also relates to ships life which is mechanically operated by
15 screw or other propelling mechanism operated by hand power.

Reference may be made to Indian Application number 11805 by SVEN ARNE SIEURIN dated 03.11.1925, titled "Improvements in launching gear for ship's life boats". This invention relates to launching gear for ships life boats, and more specifically to improvements in the devices for swinging out to lowering position
20 such life boats carried on board ships. The invention is concerned with the simplification of the operation and reduction of labor and to that end employs certain novel principles such as the use of a single rope operated by a single man for the swinging out of a life boat. Other features of importance include stabilization of the boat when ready for embarkation.

25 **However none of the inventions in prior art comprise of a device which the present invention comprises, the present invention provides a rounded life boat**

which can neither sink nor topple even in extreme conditions, with certain other features which are absent in the already existing similar inventions as mentioned in the prior art above.

The present invention is a unique rounded life boat which can neither sink nor topple
5 even in extreme weather conditions in seas and rivers. This life boat comprises of
certain other life saving features which have not been present in the prior art. The
invention comprises of features extra oxygen cylinders, and capacity to accommodate
a considerable number of persons in it. Moreover the rounded life boat is covered and
is in ball like structure which have two ballsstructures namely the inner ball structure
10 and the outer ball structure connecting each other with bearings which prevents the
two ball like structure to collide with each other. Since, inner ball structures is
independent of the outer ball structures it remains straight with slight movement even
if the outer ball structures is hit by river current, sea waves, tsunami waves, typhoon
or tornado like situations. The impact is taken by outer ball structures shielding inner
15 ball structures and its occupants from falling over. The inner ball structures can
balance even in 360° movement of outer ball structures and work in any
condition. This invention is safer than existing inventions due to its uniqueness of
shape, size and ability to maintain center of gravity in extreme conditions.

OBJECTS OF THE INVENTION

20 The primary objective of the invention is to provide a life boat.

Another objective of the invention is to provide a life boat which is extremely stable
and safe even in extreme emergencies.

Another objective of the invention is to provide a life boat which is capable of keeping
its occupants in stable & upright condition.

A further objective of the invention is to provide a life boat to save human lives in extreme weather conditions in water bodies.

A further objective of the invention is to provide a life boat which can carry sensitive materials in case of emergency in water bodies.

5 SUMMARY OF THE INVENTION

This invention provides a unique rounded life boat which can neither sink nor topple even in extreme weather conditions in seas and rivers. This life boat comprises of certain other life saving features which have not been present in the prior art. The invention comprises of features extra oxygen cylinders, and capacity to accommodate
10 up to 'x' number of persons in it. Moreover the rounded life boat is covered and is in ball like structure which have two ball namely the inner ball structure and the outer ball structure connecting each other with bearings which prevents the two ball like structure to collide with each other. Since, inner ball structure is independent of the outer ball structure; it remains straight with slight movement even if the outer ball
15 structure is hit by river current, sea waves, tsunami waves, typhoon or tornado like situations. The impact is taken by outer ball structure shielding inner ball structure and its occupants from falling over. The inner ball structure can balance even in 360° movement of outer ball and remain stable in all condition. The buoyancy factor of the life boat will keep the life boat always in the floating position over the surface of the
20 water with sufficient freeboard.

BRIEF DESCRIPTION OF THE DRAWINGS

There are ten diagrams in the specification. They describe various components as referred in the specification. Various items used in manufacturing of prototype and as described in diagrams have been mentioned here as:

S.No.	Item Name	Item Description
1.	Hatch (FIG-1,2,3)	This is an airtight hatch to seal the structure. The outer surface is curvature as per the structure curvature. Inner surface is smooth. Handles to open / close are on both inside and outside. The hatch is air tight. The hatch is made of stainless steel/Fibre glass.
1.1	Hatch – 1 (FIG-1,2,3)	This Hatch is for outer ballstructure.
1.2	Hatch – 2 (FIG-1,2,3)	This Hatch is for inner ball structure.
2.	Air Valve – 4 Nos. (FIG-1,2,3)	Two air valves either metallic or non-metallic will be placed on either side of hatches. These valves will be used to pump in or exhaust fresh air. The valves can be manual or automatic.
3.	Composite Layer (FIG-1,2)	A composite layer of steel, titanium or any light weight metal is quoted on the inner surface of outer ball structure. The bearings will hit this coating which will safeguard outer ballstructure from damage due to friction / impact of bearings during turbulence including regular wear and tear.
4.	Windows (FIG-1,2)	Windows are kept on either side of the structure of a diameter of 10". Windows are made of transparent polycarbonate and sealed within the structures. Windows for outer and inner ball structure will be at the same level when in still position.
4.1	Windows – 2 Numbers (FIG-1,2)	For outer ball structure. The composite layer at the windows shall be perforated for a clear view of the outside sea conditions.
4.2	Windows – 2 Numbers (FIG-1,2)	For inner ball structure

5	Breaks – 4 nos. (FIG-1,2)	Four rubber brakes are installed between the inner and outer ball structures to keep the complete structure in locked conditions. All four brakes shall get applied simultaneously manually.
6	Seats – 9 Nos. (FIG-1,2,4)	Seating for Nine passengers is provided on fiber glass moulded benches placed in circular form.
7	Storage Compartments (FIG-1,2,3)	The empty space beneath the seats is kept for storage of essential commodities like food, water, medicines, tools and other equipment.
8	Paddle Mechanism (FIG-1,2,3)	Paddle mechanism to steer the life boat in still water using propeller. This mechanism could be manual (Human Muscle).
9	Castor Bearing (FIG-1,2,3,4,7)	This is placed between inner and outer ball structures. This is fixed at outer surface of inner ball structure. This is fixed in the bottom portion of the inner ball structure. This is solid stainless steel structures inside of which only 20% surface area is visible and touching the outer ball structure coating. This structure can move 360 degree without any resistance.
10	Bottom Structure (FIG-1,2,4,5,6)	This is a V shaped bottom structure also made of fibre glass covering 1/4 th outer surface of the outer ball structure. This will help the life boat move in a straight direction during propulsion. This bottom structure also provides additional strength to the bottom of the life boat which also safeguards the life boat at the time of launching from davit.
11	Propeller Shaft (FIG-1,2,)	This is a concealed mechanism extending outwards from the outer shield up to the point of propeller attachment.
12	Propeller (FIG- 1,2,3)	Standard propeller at the bottom of the life boat made of brass / aluminium etc.

13	Jason Cardel (FIG-5)	Wooden ladder of width 12 cms and 45 cms wide connected with nylon / coir rope. Length of rope will be as per life boat length. This is to be used for recovery of passangers in water.
14	Suspension (FIG-7)	Suspension between steel structure and caster socket on the outer surface of inner ball structure. Suspension absorbs the movement / impact on the inner surface which is caused due to the impact of waves on outer ball structure. Suspension also reduces the momentum of impact due to launch, any sudden jerks, strong waves, impact due to collision of life boat with any object etc. Suspension could be spring, hydraulic or gas suspension.
15	Adjuster (FIG-3)	It is a rubber wheel between inner and outer ball structure and attached to a handle inside the inner ball structure for steering / moving the structures to align them for locking position. Once, the lock is applied, the function of adjuster ceases.
16	Pedalling Box (FIG-1,2,3)	The box will cover the paddling mechanism for the security of occupants. Two seats are made for pedalling on the top of the box. Ladder will be placed at the centre of the box for movement of the occupants.
17	Inside Ladder (FIG-1,2,3)	Meant for occupants to do up / down movement. This is folded ladder between the hatch and the centre of the box. The ladder is made of light weight material. ladder will be open before entry of persons and shall be folded once the life boat is filled with the occupants and before the launch.
18	Scrubber (FIG-1,2)	This is placed to remove CO ₂ from the compartment and reenergize the O ₂ system.
19	Oxygen Cylinder - 3	Three oxygen cylinders are placed inside the inner ball structure and capacity of each cylinder is 1500 Ltr. To enable

	nos. (FIG-3)	supply of O2 for Nine Passangers.
20	Rudder (FIG-1,2,6)	Rudder provide directions to life boat, rudder is fixed at the back of propeller.
21	Front Light (FIG-1,2,5,6)	LED lights Will be placed just above the windows on the bottom structure side. Flasher and spot bulbs will be fixed. These will be connected to a battery placed inside the box through cable. The front light will be connected to the battery only under locked condition.
22	Seat belt (FIG-1,2,3)	Seat belts are available / fixed on the seats for 9 occupants safely.
23	Steering wheel (FIG-1,2,3)	Steering wheel is attached to the paddle mechanism. This will work only under locked condition.
24	Maintenance Hatch (FIG-4)	The hatch is placed at the bottom of inner ball structure to maintain / repair the steering shaft, paddle shafts etc. in case required.
25	Accessory Cupboard (FIG-4)	Shall contain accessories and switches and misc. stores.
26	Solar Panel space (FIG-5,6)	Space for placing solar panels around top outer hatch.
27	Paddling Seats (FIG-1,2,3,4)	On top of the box to paddle at the time of steering.
28	Inner Layer (FIG-1,2,)	Anotherthin composite layer of steel, titanium or any light weight metal is quoted on the inner surface of inner ball structure.
29	LED Lights	LED lights are installed to lighten the inner ball structure.

	(FIG-3)	
30	Folding Shafts (FIG-1,2,3)	Two separate folding shafts are placed to attach propeller and rudder respectively.
31	Tools Storage (FIG-1,2,3)	To keep mechanical tools and spares
32	Battery Box (FIG-1,2,)	To keep batteries under peddling seats to keep batteries.
33	Floor (FIG-3)	Anti-skid floor
34	Life Lines (FIG-6)	Life lines are made to help in rescue of nam overboard.
35	Hook	For towing of life boat.
36	Storage (FIG-4)	For misc. stores.
37	Rudder Shaft (FIG-1)	Connecting rudder with the main central position.

STATEMENT OF THE INVENTION

Accordingly, the present invention provides a rounded life boat for safe transport during emergency situations in a water body, said life boat having a number of 5 structures and components as herein-defined for its' working; said life boat having capacity to accommodate a plurality of persons and other necessary materials and equipment in the innermost structure, wherein the outermost and biggest structure is always round/spherical in shape and is having a number of concentric structures of different sizes/diameter fitted within it, the smallest structure being the innermost 10 structure of any shape; the structures of bigger diameter fitted around the smaller ones with a gap in between; said structures fastened together by means which keep them

together at the same time avoiding any collision; with all the passengers being in the innermost structure during emergency such that said life boat is able to move around 360 degrees during extreme emergency situations while always keeping the inner ball structure carrying passengers in almost immobile position, thus making the device highly safe even during the extreme emergency conditions while inside a water body.

DETAILED DESCRIPTION OF THE INVENTION

It should be noted that the particular description and embodiments set forth in the specification below are merely exemplary of the wide variety and arrangement of instructions which can be employed with the present invention. The present invention may be embodied in other specific forms without departing from the spirit or essential characteristics thereof. All the features disclosed in this specification may be replaced by similar other or alternative features performing similar or same or equivalent purposes. Thus, unless expressly stated otherwise, they all are within the scope of present invention. Various modifications or substitutions are also possible without departing from the scope or spirit of the present invention. Therefore it is to be understood that this specification has been described by way of the most preferred embodiments and for the purposes of illustration and not limitation.

This present invention provides a unique rounded life boat which can neither sink nor topple even in extreme weather conditions in seas and rivers. There are two ball like structures in this rounded life boat. The small ball structure is fitted inside the bigger ball structure and then bearings are fitted on the outer surface of inner ball structure which prevents both the balls from collision with each other and small inner ball structure can move freely inside the outer bigger ball structure and it prevents the persons sitting inside the inner ball structure from toppling.

This rounded life boat comprises of certain other life saving features which have not been present in the prior art. The invention comprises of features extra oxygen cylinders, and capacity to accommodate up to 'x' numbers of persons in it. Moreover

the rounded life boat is covered and is in ball like structure which have two ball structure namely the inner ball structure and the outer ball structure connecting each other with bearings which prevents the two ball like structure to collide with each other. Since, inner ball structure is independent of the outer ball structure, it remains
5 straight with slight movement even if the outer ball structure is hit by river current, sea waves, tsunami waves, typhoon or tornado like situations. The impact is taken by outer ball structure shielding inner ball structure and its occupants from falling over. The inner ball structure can balance even in 360° movement of outer ball structure and work in any condition. Even though the life boat will be moving in 360
10 degree the person sitting inside the life boat will be static and will always be in the upright direction. The buoyancy factor of the life boat will keep the life boat always in the floating position over the surface of the water.

The outer ball structure and inner ball structure of this invention are built with a light metal or fiber glass. Inner surface of outer ball structure is coated with composite
15 layer made of titanium, steel or any other light metal or solid non-metal. Lower half of the outer ball structure is heavier due to addition of bottom structure. The shape of the outer ball structure can be extended to help the life boat in floating and steering.

Total weight and counter weight of the life boat is built into the system by default of location of passengers and accessories in the lower end of both the balls. Both the
20 inner ball structure and the outer ball structure comprises of air tight hatch on the top. The outer ball structure has air valve at the top and also a propulsion system at the bottom. This rounded life boat further comprises of bearings or mechanical structure between inner and outer ball structure which prevents both the inner and outer ball structures from colliding with each other. This invention further comprises of rubber
25 brakes which helps in keeping both the ball structures static. The air tight hatch in this invention are used to close the outer ball structure and inner ball structure in emergency like Tsunami, Flood, Typhoon, Hurricane etc. and safely carrying the

persons inside the inner ball structure. The position of the person inside the inner ball will be always in upright position.

The rounded life boat is static when it is loaded or unloaded on ships and the brakes are applied so that the movement of inner ball structure can be restricted and the
5 doors can be aligned to be open for the movement of persons. The invention comprises of weight balancing position which balances the weight of the life boat automatically. The inner ball structure of the invention has weight of the persons sitting inside and the outer ball structure has weight of a propulsion system which helps in keeping it at its position. In calm water, due to weight at the bottom of the
10 inner ball structure and weight of the propulsion system at the bottom of the outer wall, keeps both in line. When the rounded life boat is in turbulent water then it is unlocked and the structures are in free movement stage in order to adjust itself against any extreme movements.

Besides the oxygen already available in the inner ball structure, oxygen cylinders are
15 kept inside the inner ball structure to be used in case of emergency. In calm water, air valve fitted in the outer ball structure shall be opened to let fresh air inside. These valves could be automatic or manually operated.

The life boat shall not be propelled in rough water. Once the roughness subsided and the sea/water is calm, the brakes shall be applied and inner and outer structures shall
20 be stabilized. Hatches shall be opened/windows on either sides to be used to have a clear view of the path to steer the life boat. Now, the propulsion rod will be attached to the propeller and the life boat shall be propelled using human muscle. To facilitate easy steering and negotiation in water, the lower ball structure has been hydrodynamically designed which will help guide the lifeboat to move forward.

This rounded life life boat further comprises of a doors on the outer and inner ball structures , chairs, valves, paddle, engine, propulsion system, and other equipment necessary during extreme emergency situation in sea and river.

The size of the life boat can be customized to accommodate any number of persons 5 depending upon the requirement and as per the application/user.

The inner ball structure can be of various shapes like cube, cuboid etc. and the outer surface of outer ball structure can also be of any shape required for stability and steering, keeping the spherical shape of the inner side of the outer ball structure 10 intact.

So accordingly, the present invention provides a rounded life boat for safe transport during extreme emergency situations in a water body, said life boat having a number of structures and components as herein-defined for its' working; said life boat having 15 capacity to accommodate a plurality of persons and other necessary materials and equipment in the innermost structure, wherein the inner side of outermost and biggest structure is always round/spherical in shape and is having a number of concentric structures of different sizes/diameter fitted within it, the smallest structure being the innermost structure of any shape; the structures of bigger diameter fitted around the 20 smaller ones with a gap in between; said structures fastened together by means which keep them together at the same time avoiding any collision; with all the passengers being in the innermost structure during emergency such that said life boat is able to move around 360 degrees during emergency situations while always keeping the inner ball structure carrying passengers in almost immobile position, thus making the 25 device highly safe even during the extreme emergency conditions while inside a water body.

In a preferred embodiment, all the inner ball structures can be of various shapes and sizes and the outer surface of outermost structure can also be of any shape and size required for stability and steering, as per the requirement, keeping the spherical shape of the inner side of the outermost structure intact.

5 In an embodiment, said water body is sea or river or any such body of water as herein defined.

In another embodiment, said structures are preferably in the shape of a ball, i.e. spherical shape.

In another embodiment, said inner ball structure is placed inside outer ball structure
10 separated by bearings and is equipped with an engine and paddle operated with a propulsion system.

In another embodiment, said life boat has preferably two spherical/ball like structures, namely inner ball structure and outer ball structure.

In another embodiment, all the structures are separated from each other by bearings to
15 prevent collision with each other.

In another embodiment, said innermost structure is almost immobile in angle or orientation even while in extreme conditions in any given water body.

In another embodiment, the users inside the innermost structure will be in static and upright direction even in 360 degree movement of the entire life boat.

20 In another embodiment, said inner and outer ball structures are preferably made up of metal or fiber glass materials.

In another embodiment, the inner layer of the outer ball structure is preferably coated with composite materials made of titanium, steel or any other light metal or solid non-metal.

In another embodiment, a bottom structure is preferably added to the lower side of the outer ball structure.

In another embodiment, the said outer ball structure can be extended to help the life boat in floating and steering.

5 In another embodiment, the said outer and inner ball structures comprise of air tight hatch on the top.

In another embodiment, said life boat has valves at the top.

In another embodiment, said life boat comprises of a propulsion system.

In another embodiment, said life boat comprises of rubber brakes to keep both the
10 structures static.

In another embodiment, said life boat comprises of weight balancing position to balance the life boat automatically while in emergency.

In another embodiment, said life boat comprises of oxygen cylinders for emergency situation.

15 In another embodiment, said air valves can be opened in calm water for fresh air.

In another embodiment, said valves are either automatic or manually operated.

In another embodiment, the inner part of the outer ball structure preferably comprises a layer of a steel sheet to strengthen it against sea impact.

In another embodiment, said life boat comprises of a propeller and a shaft.

20 In another embodiment, said life boat comprises of shock absorbers to protect the life boat from sea impact.

This type of life boat shall never sink nor topple even in extreme conditions.

This is based mainly on the principal that if we fit in a smaller structure inside a bigger structure and fit bearings on the outer surface of inner ball structure, then in this condition, both structures shall not collide with each other and small inner ball structure can move freely inside the outside bigger structure. Now, if any person is sitting in the inner ball structure, it can never be toppled.

Since the inner ball structure is independent of the outer ball structure, it remains straight with slight movement even if the outer ball structure is hit by river current, sea waves, tsunami waves, typhoon or tornado like situations. The impact is taken by outer ball structure shielding inner ball structures and its occupants from falling over.

10 The inner ball structure can balance even in 360° movement of outer ball structure and work in any condition.

Construction of the prototype, for the purposes of illustration only:

Prototype was constructed as a two layer structure life boat, with both the layers in spherical shape only.

- 15 1. Outer ball structure and Inner ball structure are built with a light metal or fiber glass. Inner layer of outer ball structure is coated with composite layer made of titanium, steel or any other light metal or solid non-metal. Lower half of the outer ball structure is heavier due to addition of bottom structure. We can extend the shape for outer ball structure to help the life boat in floating and steering.
- 20 2. All weight and counter weight is in the lower end of both the structures.
3. Both structures have air tight hatch on the top.
4. Outer ball structure has an air valve at the top.
5. Outer ball structure has a propulsion system at the bottom.
- 25 6. There are bearings or mechanical structure between inner and outer ball structure.

7. Both structures in static condition are kept together with rubber brakes.

Working of the invention:

In case of emergency like Tsunami, Flood, Typhoon, Hurricane etc. plurality of persons shall be seated inside the inner ball structure at the bottom and inner and 5 outer ball structures are closed with air tight hatch. The water / waves will affect the outer ball structure, keeping the persons inside the inner ball structure at upright position always.

Balancing:

There are two stages. One is the standing / locked stage and other is the turbulent or 10 unlocked stage.

The locked stage is the stage when the life boat is stationary, when it is loaded and unloaded, when the water is calm and steering is happening. The brakes are applied so that the movement of inner ball structure is restricted and the doors are aligned to be opened and movement of persons takes place. The life boat has weight balancing 15 the position. The inner ball structure has weight of the persons and the outer ball structure has a propulsion system keeping it at its position. In calm water, due to weight at the bottom in the inner ball structure and propulsion system at the bottom in the outer ball structure, keeps both in line.

The unlocked stage is when the life boat is in turbulent water and at this stage the 20 structures are in free movement stage and adjust itself against any extreme movements.

Oxygen Supply:

Besides the oxygen available in the inner ball structure, oxygen cylinders are kept inside the life boat to be used in case of emergency. In calm water, air valve fitted in 25 the outer ball structure shall be opened to let fresh air inside. These valves could be automatic or manually operated.

Propulsion

The life boat shall not be propelled in rough water. Once, the roughness subsided and the sea/water body is calm, the brakes shall be applied and inner and outer spheres shall be stabilized. Hatches shall be opened to have a clear view of the path to steer
5 the life boat. Now, the propulsion rod will be attached to the propeller and the life boat shall be propelled using human muscle. Since spherical structure can't be steered in the water, a bottom structure is provided at the front which will help guide the propeller to move forward.

Use: For saving human lives and sensitive items in extreme sea emergencies and for
10 carrying sensitive material.

The following example is for the purposes of illustration only and therefore should not be construed to limit the scope of the present invention:

Prototype construction for testing purposes

A life boat as per the teachings of this invention has been manufactured as per the
15 dimensions provided below and tested successfully in a water body:

The diameter of outer ball structure shall be around 3000 mm. The thickness of the outer ball structure of the life boat is 20mm (Fig.1); approximately 2260 kg of fiber glass is used for the outer ball structure. The inner surface of the outer ball structure is coated with a composite layer of steel/titanium metal with a thickness of 1 mm and an
20 additional weight of 211 Kg. The total weight of the outer ball structure is 2471 kg. The surface area (B, Fig.1) of the outer ball structure shall be approximately 28.26 m² and volume shall be 14.13 m³ giving the ball a buoyancy of 14000 Kg. This defines the maximum capacity of the life boat for this dimension.

The diameter of inner ball structure shall be 2000 mm. The thickness of the inner ball
25 structure of the life boat is 12.5 mm (Fig.1), approximately 630 kg of fiber glass is

used for the inner ball structure. The inner surface of the inner ball structure is coated with a composite layer of steel / titanium metal with a thickness of 1 mm and an additional weight of 100 Kg. The total weight of the inner ball structure is 730 kg. The surface area of the inner ball structure shall be approximately 12.56 m² and 5 volume shall be 4.19 m³.

The gap between the outer ball structure and inner ball structure is 500 mm (Fig.2).

Approximate Weight of other items:

1. Further this rounded life boat comprises of 4 bearings (Fig.3) which weights in 160kg.
- 10 2. Storage and sheet arrangement: 100 Kg
3. Paddling sheet and paddling box: 25 Kg
4. Paddling system: 40 Kg.
5. All other equipment / items: 200 Kg
6. Food and drinking water: 300 kg
- 15 7. Oxygen Cylinder: 54 Kg
8. Propulsion System: 100 Kg
9. Bottom structure: 300 Kg
10. Brake and Adjustor: 60 Kg

Total Weight: 1339 kg

- 20 Weight of persons (9 Numbers): 1000 Kg.

Grand Total of the fully loaded life boat: 5538 Kg.

Maximum buoyancy: 14000 Kg

A brief list of equipment used in prototype creation is:

- Boat hook

- Buoyant bailer
- Bucket
- Compass
- Sea anchor
- 5 • Painter
- Hatchet
- Fresh water
- Drinking cup
- Food ration
- 10 • Water proof electric torch
- Rocket parachute flare
- Hand flare
- Buoyant smoke signal
- Daylight signaling mirror
- 15 • Whistle
- First-aid outfit
- Jack knife
- Can openers
- Buoyant rescue quoit
- 20 • Manual bailing pump
- Fishing tackle
- Search light
- Thermal protective aids
- Anti-seasickness medicine
- 25 • Lifesaving signal table
- Rope ladder for embarking
- Tool set for paddling with box

- Safety belt
- Seasickness bag
- Radar reflector
- Survival manual
- 5 • Portable fire extinguisher
- Solar charger
- O2 cylinder
- Co2 scrubber
- I M O symbol
- 10 • 12v battery
- 12v exhaust fan
- Battery Charger

Advantages of the invention:

- Extremely safe and secure evacuation mode from passenger / cargo ships
- 15 • Covered and comprises of oxygen cylinders
- Can accommodate up to 'x' persons at a time
- Can be easily accommodated on ships
- It can be operated by paddle (Human Muscle)
- It contains closed chambers
- 20 • Extremely effective mode of survivability even during Tsunami.
- Extremely safe even in high sea and river waves
- It can be used during any type of sea and river emergency
- Can easily accommodate drinking water and food up to 300kg.
- Can provide oxygen for 'x' persons at a time
- 25 • Inner ball structure remains almost static and so do persons inside inner ball
- Enough space to carry essential materials

CLAIMS:

1. A rounded life boat for safe transport during emergency situations in a water body, said life boat having a number of structures and components as herein-defined for its'working; said life boat having capacity toaccommodate a
5 plurality of persons and other necessary materials and equipmentin the innermost structure, wherein the inner side of outermost and biggest structure isalways round/spherical in shape andis having a number of concentric structures of different sizes/diameter fittedwithin it,the smallest structure being the innermost structureof any shape; the structures of bigger diameter
10 fitted around the smaller ones with a gap in between;said structures fastened together by means which keep them together at the same time avoiding any collision; with all the passengers being in the innermost structure during emergency such that said life boat is able to move around 360 degrees during emergency situations while always keeping the inner ball structure carrying
15 passengers in almost immobile position, thus making the device highly safe even during the extreme emergency conditions while inside a water body.
2. The life boat as claimed in claim 1, wherein all the inner ball structures can be of various shapes and sizes and the outer surface of outermost structure can
20 also be of any shape and size required for stability and steering, as per the requirement, keeping the spherical shape of the inner side of the outermost structure intact.
3. The life boat as claimed in claim 1, wherein said water body is sea or river or
25 any such body of water as herein defined.

4. The life boat as claimed in claim 1, wherein said structures are preferably in the shape of a ball, i.e. spherical shape.
5. The life boat as claimed in claim 1, wherein said inner ball structure is placed
5 inside outer ball structure separated by bearings and is equipped with an engine and paddle operated with a propulsion system.
6. The life boat as claimed in claim 1, wherein said life boat has preferably two spherical/ball like structures, namely inner ball and outer ball.
10
7. The life boat as claimed in claim 1, wherein all the structures are separated from each other by bearings to prevent collision with each other.
8. The life boat as claimed in claim 1, wherein said innermost structure is almost
15 immobile in angle or orientation even while in extreme conditions in any given water body.
9. The life boat as claimed in claim 1, wherein the users inside the innermost structure will be in static and upright direction even in 360 degree movement
20 of the entire life boat.
10. The life boat as claimed in claim 1, wherein said inner and outer ball structures are preferably made up of metal or fiber glass materials.
11. The life boat as claimed in claim 1, wherein the inner layer of the outer ball
25 structure is preferably coated with composite materials made of titanium, steel or any other light metal or solid non-metal.

12. The life boat as claimed in claim 1, wherein a bottom structure is preferably added to the lower side of the outer ball structure.
13. The life boat as claimed in claim 1, wherein the said outer ball structure can be extended to help the life boat in floating and steering.
14. The life boat as claimed in claim 1, wherein the said outer and inner ball structures comprise of air tight hatch on the top.
15. The life boat as claimed in claim 1, wherein said life boat has valves at the top.
16. The life boat as claimed in claim 1, wherein said life boat comprises of a propulsion system.
17. The life boat as claimed in claim 1, wherein said life boat comprises of rubber brakes to keep both the structures static.
18. The life boat as claimed in claim 1, wherein said life boat comprises of weight balancing position to balance the boat automatically while in emergency.
19. The life boat as claimed in claim 1, wherein said life boat comprises of oxygen cylinders for emergency situation.
20. The life boat as claimed in claim 12, wherein said air valves can be opened in calm water for fresh air.

21. The life boat as claimed in claim 12, wherein the said valves are either automatic or manually operated.

5 22. The life boat as claimed in claim 1, wherein the inner part of the outer ball structure preferably comprises a layer of a steel sheet to strengthen it against sea impact.

10 23. The life boat as claimed in claim 1, wherein said life boat comprises of a propeller and a shaft.

24. The life boat as claimed in claim 1, wherein said life boat comprises of shock absorbers to protect the boat from sea impact.

15 25. A rounded life boat for safe transport during emergency situations in a water body, substantially as hereinbefore described with reference to the accompanying drawings and specification.

20

25

30

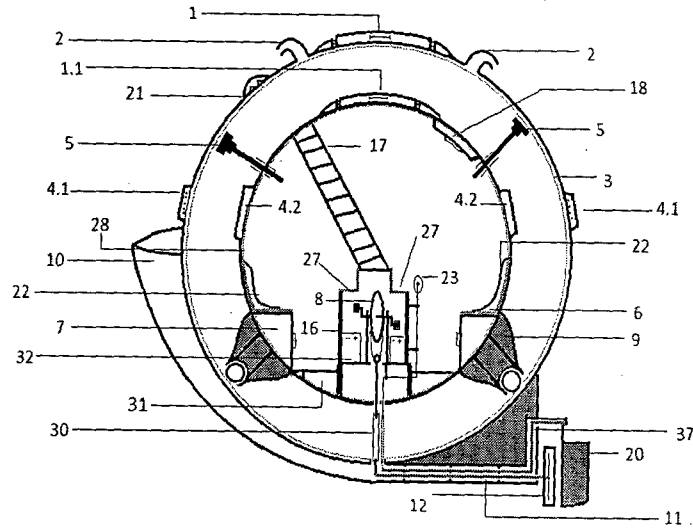

FIG-1

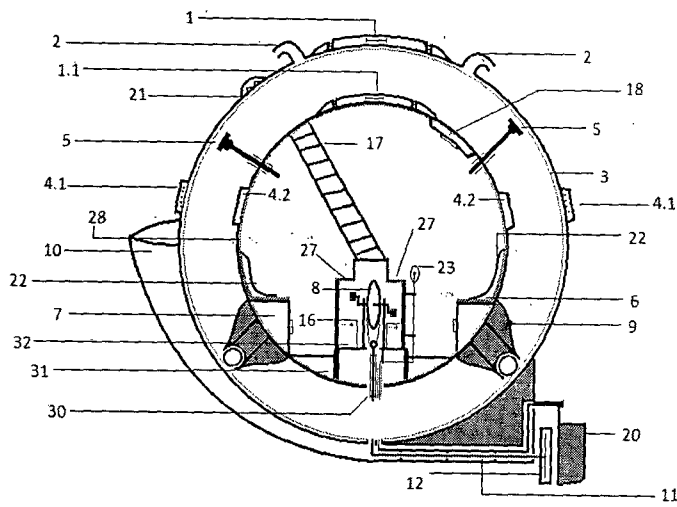

FIG-2

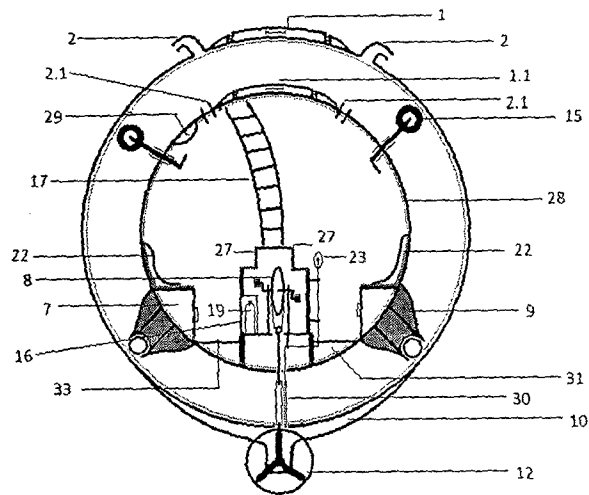

FIG-3

3/5

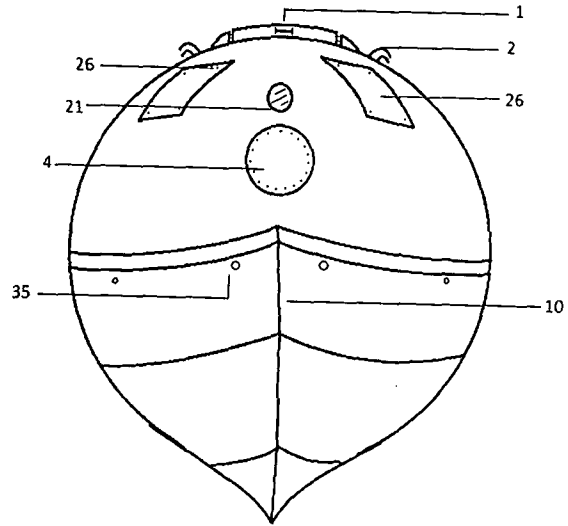

FIG-5

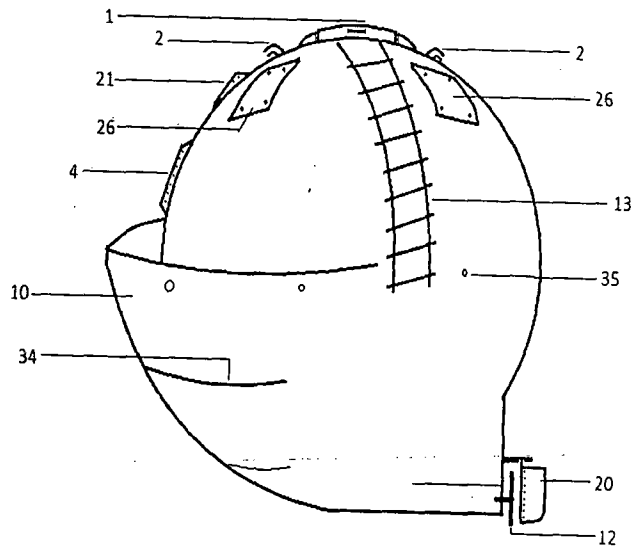

FIG-6

