

(19) World Intellectual Property Organization
International Bureau



(43) International Publication Date
11 October 2001 (11.10.2001)

PCT

(10) International Publication Number
WO 01/75575 A2

- (51) International Patent Classification⁷: **G06F 3/033**
- (21) International Application Number: PCT/GB01/01429
- (22) International Filing Date: 30 March 2001 (30.03.2001)
- (25) Filing Language: English
- (26) Publication Language: English
- (30) Priority Data:
0007679.4 30 March 2000 (30.03.2000) GB
- (71) Applicant (*for all designated States except US*): **ELECTROTEXTILES COMPANY LIMITED** [GB/GB]; Charter Court, Midland Road, Hemel Hempstead, Hertfordshire HP2 5GE (GB).
- (72) Inventors; and
- (75) Inventors/Applicants (*for US only*): **SANDBACH, David, Lee** [GB/GB]; Flat C, 9 Westbourne Road, London N7 8AR (GB). **CHAPMAN, Christopher** [GB/GB]; 2 Spring Lane, Watlington, Oxon OX9 5QL (GB).
- (74) Agent: **ATKINSON, Ralph**; Atkinson Burrington, 25-29 President Buildings, President Way, Sheffield S4 7UR (GB).
- (81) Designated States (*national*): AE, AG, AL, AM, AT, AU, AZ, BA, BB, BG, BR, BY, BZ, CA, CH, CN, CR, CU, CZ, DE, DK, DM, DZ, EE, ES, FI, GB, GD, GE, GH, GM, HR, HU, ID, IL, IN, IS, JP, KE, KG, KP, KR, KZ, LC, LK, LR, LS, LT, LU, LV, MA, MD, MG, MK, MN, MW, MX, MZ, NO, NZ, PL, PT, RO, RU, SD, SE, SG, SI, SK, SL, TJ, TM, TR, TT, TZ, UA, UG, US, UZ, VN, YU, ZA, ZW.
- (84) Designated States (*regional*): ARIPO patent (GH, GM, KE, LS, MW, MZ, SD, SL, SZ, TZ, UG, ZW), Eurasian patent (AM, AZ, BY, KG, KZ, MD, RU, TJ, TM), European patent (AT, BE, CH, CY, DE, DK, ES, FI, FR, GB, GR, IE, IT, LU, MC, NL, PT, SE, TR), OAPI patent (BF, BJ, CF, CG, CI, CM, GA, GN, GW, ML, MR, NE, SN, TD, TG).
- Published:**
— *without international search report and to be republished upon receipt of that report*
- For two-letter codes and other abbreviations, refer to the "Guidance Notes on Codes and Abbreviations" appearing at the beginning of each regular issue of the PCT Gazette.*



WO 01/75575 A2

(54) Title: DATA PROCESSING APPARATUS

(57) Abstract: Data processing apparatus (101 and 102) configured to receive signals from an input sensor (106) arranged to duplicate or replace operations of a keyboard, in which the signals correspond to positions of mechanical interactions with the sensor (106). The apparatus comprises processing means (1202) configured to process data derived from the input sensor including positional data corresponding to the position of a mechanical interaction with said input sensor (106) and a second data type corresponding to the absence of a mechanical interaction with said input sensor. The processing means (1202) is configured to generate data representing a first character in response to processing an item of data of said second type followed by positional data corresponding to a first position, and to generate data representing a different second character in response to processing positional data corresponding to a different second position followed by an item of data of said second type.

Data Processing Apparatus

The present invention relates to a data processing apparatus configured to receive signals from an input sensor arranged to duplicate or replace operations of a keyboard.

Conventional electronic keyboards comprise of an array of sensors (switches), each corresponding to a particular key. During use, the sensors are interrogated sequentially to determine which are being pressed.

Input sensors arranged to replace operations of a conventional keyboard are known, an example being the touch screen of a hand-held computer, such as a Palm (RTM) Vx, when used in a keyboard mode. In keyboard mode, an array of keys are displayed on the screen, below an area into which typing may be produced. A particular letter, number or symbol may be selected by pressing the screen with a stylus at the correct location. On pressing the screen, the particular key changes colour to indicate that its selection has been recognised by the computer, and on releasing the pressure, the selected letter is added to the typing on screen.

A disadvantage of this type of system, is that the computer is only able to accurately recognise individual "key-presses". If two keys are pressed such that the second is pressed before the first is released, neither of the pressed keys are interpreted by the computer as having been pressed. In circumstances where over-lapping key-presses can take place, for instance where the touch screen is large enough to accept finger presses from more than one digit, this limitation tends to provide for slow input of data compared to a conventional keyboard system.

According to a first aspect of the present invention there is provided data processing apparatus configured to receive signals from an input sensor arranged to duplicate or replace operations of a keyboard, said signals corresponding to positions of mechanical interactions with said sensor, said apparatus comprising: processing means configured to process data derived from said input sensor including positional data corresponding to the position of a mechanical interaction with said input sensor and a second data type corresponding to the absence of a mechanical interaction with said input sensor, wherein said processing means is configured to generate data representing a first character in response to processing an item of data of said second type followed by positional data corresponding to a first position, and to generate data representing a different second character in response to processing positional data corresponding to a different second position followed by an item of data of said second type.

Preferably said sensor is an XY position sensor, and said positional data corresponds to the position within a continuous area defined by said sensor. For the purposes of this specification, an XY position sensor is defined to be a sensor which is capable of providing two electrical values that each relate to the two dimensional position of a mechanical interaction on the surface of the sensor.

The processing means may comprise a single processing device. However, in a preferred embodiment, said processing means comprises two processing devices, such that: one of said processing devices is configured to receive said signals from said input sensor and to generate said positional data and data of said second data type; and the second of

said processing devices is configured to process said positional data and data of said second data type to generate data corresponding to displayable characters. Preferably, the first processing device is configured to generate a stream of data comprising positional data, and to send
5 positional data to said second processing device only when an item of positional data differs from the immediately preceding item of sent data by more than a predetermined amount.

According to a second aspect of the present invention there is provided a method of processing signals received from an input sensor
10 arranged to replace operations of a keyboard, said signals corresponding to positions of mechanical interactions with said sensor, wherein said method comprises: processing data derived from said signals, said data comprising positional data corresponding to the position of a mechanical interaction with said input sensor and a second data type corresponding to the
15 absence of a mechanical interaction with said input sensor, such that data representing a first character is generated in response to processing an item of data of said second type followed by positional data corresponding to a first position, and data representing a different second character is generated in response to processing positional data corresponding to a
20 different second position followed by an item of data of said second type.

The invention will now be described by way of example only, with reference to the accompanying drawings in which:

Figure 1 shows hand held computer **101** and attached manually operable keyboard **102** embodying the present invention;

25 *Figure 2* shows the keyboard **102** of *Figure 1* disconnected;

Figure 3 shows an exploded perspective view of the keyboard of *Figure 2*, illustrating its constituent layers;

Figure 4A and 4B show the electrically conductive fabric layers **301** and **302** of *Figure 3* in more detail;

5 *Figure 5* shows an interface circuit **501**, present in the computer receiving assembly **105** of *Figure 1*;

Figures 6A, 6B, 6C and 6D illustrate an overview of the measurements made by interface circuit **501**;

10 *Figure 7* shows a flow chart of the program running within the peripheral interface circuit of *Figure 5*;

Figure 8 shows step **701** of *Figure 7* in further detail;

Figure 9 shows step **703** of *Figure 7* in further detail;

Figure 10 shows step **705** of *Figure 7* in further detail;

Figure 11 shows a rear view of the computer **101**;

15 *Figure 12* shows a schematic view of computer **101**;

Figure 13 shows a flow chart illustrating the keyboard application program running in the computer **101**;

Figure 14 shows a photocopier **1401** providing an alternative embodiment of the present invention;

20 *Figure 15* shows schematically a touch sensitive screen **1403** and a micro-controller **1501** located in the photocopier **1401**.

Figure 1

25 A hand held computer **101** and attached manually operable keyboard **102**, embodying the present invention are shown in *Figure 1*. The computer **101** is a Palm (RTM) Vx with a touch sensitive LCD display. In

some modes of operation, the computer **101** displays a keyboard on its LCD display **103** and keys may be selected by manual operation of a stylus upon the screen **103**. The purpose of the keyboard **102** is to effectively replace this displayed keyboard, thereby allowing an operator to make use of the keyboard by direct application of their fingers, in a similar manner to
5 the operation of a standard keyboard. In this way, the entry of alphanumeric data can take place much more quickly, in a way which is generally more familiar to operators and users.

The keyboard comprises an XY position sensor **106** manufactured
10 from a number of layers of material, such that two conducting layers are separated by non-conducting layers. The non-conducting layers are configured to allow said conducting layers to become electrically connected at a the location of a key, when that key is pressed. The keyboard also includes a flexible cable **104** which physically and electrically connects the
15 conducting layers of the sensor **106** to a computer receiving assembly **105**. The computer receiving assembly **105** contains an interface circuit and a connector configured to connect with the connector located at the lower rear of the computer **101**. Thus, connections on the receiving assembly **105** make electrical connection with the serial port of the computer **101**, along with its
20 ground and power supply terminals. The computer **101** supplies approximately four volts to the interface circuit when its batteries are fully charged but this may drop to approximately 3.7 volts as the batteries become low on charge. For the purposes of this description it will be assumed that the interface circuit receives four volts from the computer **101**.

25 In an alternative embodiment, the interface circuit is powered by batteries located within the computer receiving assembly **105**.

Before using the keyboard **102**, keyboard application software is firstly downloaded to the computer **101**. Thus, in a conventional manner, the Palm, with the keyboard detached, is placed in its Hotsync cradle which is connected by its cable to a personal computer (PC) or other computer suitable for the process. The keyboard application software, which may be resident for example on a disc in the floppy disc drive or CD-ROM drive of the PC, is selected by the user for installation, and then transferred to the computer **101** by a Hotsync process.

During operation of the keyboard, the interface circuitry applies voltages across a first conducting layer within the keyboard **101** and when a user presses an individual key, the interface circuitry measures voltages appearing on a second conducting layer to determine an X co-ordinate of the key being pressed. It then applies a voltage across the second conducting layer and measures voltages appearing on the first conducting layer to determine an Y co-ordinate. Having detected the X and Y location of the pressed key, the interface circuitry supplies data to the computer **101** relating to said X and Y location. With the keyboard application installed and running, the computer **101** is able to receive the X and Y location data and generate a character corresponding to the pressed key. Thus, when the "G" key is pressed a "G" or "g" appears on the display **103**.

Unlike previous arrangements, in which the keyboard comprises an X and Y location sensor, the computer and keyboard arrangement of *Figure 1* is able to receive and interpret two key-presses that overlap in time. i.e. when a second key is pressed before a first key is released, this arrangement recognises both the first and second key-presses. Such overlapping key-presses are likely to occur when a user types quickly. In fact, because such

overlapping key-presses are acceptable to the system of *Figure 1*, the user is able to accurately type more quickly than they otherwise could.

Figure 2

5 The keyboard **102** of *Figure 1* is shown disconnected in *Figure 2*. The keyboard **102** is constructed from nine layers of textile fabric and a layer containing key registration devices. This construction has been found to be durable, and electrically sound, while providing the flexibility associated with textile fabrics. The key registration devices cause the upper surface of the
10 keyboard to protrude at locations, such as location **201**, corresponding to the keys. The keys correspond to letters, numerals and functions found on conventional alpha-numeric keyboards. The key registration devices are over-centre silicone rubber mouldings which deform when pressed and cause the conducting layers of fabric in the sensor **106** to come into electrical
15 contact at their location.

 The computer receiving assembly **105** is configured to engage the lower edge of the computer **101**, in the vicinity of the computer's electrical connector, to secure the computer **101** in position. A portion **202** of the receiving assembly **105**, which supports the rear surface of the computer **101**
20 during use, houses the interface circuit. A pair of legs **203** are pivotally attached to the portion **202** which may be used to support the computer **101** in an upright position during use.

Figure 3

25 An exploded perspective view of the keyboard of *Figure 2*, illustrating its constituent layers, is shown in *Figure 3*. The fabric keyboard **102**

comprises ten individual constituent layers, including a first electrically
conductive layer **301** and a second electrically conductive layer **302**. Both
of the electrically conductive fabric layers **301** and **302** have electrically
conductive carbon-coated nylon fibres woven or knitted together such that
5 each conductive layer is capable of conducting an electrical current in any
direction along the plane of the layer.

The first electrically conductive layer **301** has conductive tracks **311**
and **312** forming an electrical contact along the left and the right edges of
the fabric keyboard respectively. The conducting tracks may be fabricated
10 from fabric coated with conductive metals, such as silver or nickel. Material
of this type is readily available and is used extensively for shielding
equipment from electromagnetic interference. The tracks are secured to the
conductive layers **301** and **302** using a conductive adhesive.

The tracks **311** and **312** are highly conductive compared to the
15 carbon coated fabric of sheets **301** and **302**. Accordingly, a voltage gradient
may be applied across the first electrically conductive layer **301** between
the right and left edges of the detector (i.e. in an X-axis direction). The
second electrically conductive layer **302** has conductive tracks **313** and **314**
providing electrical contact along the top and bottom edges of the fabric
20 layer respectively. Accordingly, a voltage may be applied across the second
electrically conductive fabric layer **302** in a direction perpendicular to that
which a voltage is applied across the first electrically conductive layer **301**
(i.e. in the Y-axis direction).

The uppermost layer of the fabric keyboard is a continuous fabric
25 layer **303** which has printed on its upper surface graphical representations
corresponding to the alpha numeric keys of the keyboard. The graphical

representations are preferably screen printed onto the fabric layer and, during the preferred construction process, the printing of the alpha-numerical graphical representations is performed after the fabric keyboard has been assembled. Furthermore, the fabric layer **303** is preferably made from a stretchable or heat formable fabric so as to enable the fabric to be manipulated to receive the protrusions of the over centre moulding layer **304**.

The over centre moulding layer **304** is, in this embodiment, a continuous silicon rubber sheet having key registration device mouldings protruding on its upper surface. The key registration device mouldings protruding from the upper surface layer **304** are specifically moulded so as to align with the alpha numerical graphical representations shown on the uppermost layer **303**.

There are five layers located in between the first electrically conductive layer **301** and the second electrically conductive layer **302**. A first masking layer **305** and a second masking layer **306** contact the innermost surfaces of the electrically conductive layers **301** and **302** respectively. Both masking layers **305** and **306** are composed of a flexible tear resistant fabric with a laminate coating of polyurethane applied to a surface of the fabric. In an alternative embodiment, masking layers **305** and **306** are sheets of polyurethane alone without any fabric constituent.

A series of circular holes **315** have been punched through the masking layers **305** and **306**. Each of these holes is located so as to align with a corresponding key registration device moulding **316** of layer **304**. During the use of the keyboard, the masking layers prevent electrical contact occurring between a central conducting layer **307** and either of the

outer conducting layers **301** and **302**, except at locations which correspond to keys. Therefore, accidental compression of the keyboard at locations between the keys does not affect the operation of the keyboard.

5 Located in between the masking layers **305** and **306** are insulating mesh layers **308** and **309**. The insulating layers **308** and **309** are woven or knitted with a relatively wide spacing between fibres so that the conductive layers are separated while at the same time allowing conduction to take place between the conducting layers when mechanical pressure is applied. The presence of these insulating layers ensures that the overall
10 construction may be folded and flexed or wrapped around objects without causing the two conductive layers to be brought into electrical contact and thereby producing an erroneous contact identification.

Located between the insulating mesh layers **308** and **309** is the central conductive layer **307** which is configured to conduct an electric
15 current from the first electrically conductive fabric layer **301** to the second electrically conductive layer **302** (i.e. in the Z axis direction) whilst substantially preventing lateral current flow along the plane of the sheet (i.e. in the X and Y axis directions).

The central conductive layer **307** is constructed by knitting a
20 polyester yarn of twenty-four decitex filaments having a single conductive filament twisted therein, such that the conductive filament appears relatively randomly in the completed knitted product. In addition, the central conductive layer **307** has a conductance perpendicular to the plane of the device (in the z axis) that increases as it is placed into pressure thereby
25 facilitating increasing conduction between the outer conductive layers during a mechanical interaction, of increasing pressure.

A final fabric layer **317** forms the under surface of the fabric keyboard. This layer is preferably a durable fabric cover configured to provide protection to the inner encapsulated layers of the fabric keyboard. In the preferred embodiment, the under surface of layer **317** is laminated with patches of rubber to provide a high co-efficient of friction between the keyboard and any surface onto which the keyboard is placed.

The ten layers forming the fabric keyboard are mechanically secured together by an adhesive provided around the perimeter edges of the constituent fabric layers.

In alternative constructions to the fabric sensor **106**, one of the two masking layers **305** and **306** are absent. In other alternative constructions, one or more of layers **303**, **316**, **315**, **307**, **309**, **306** and **317** are absent. Therefore, in a very simple construction, a sensor representing a keyboard may be constructed from just the conductive layers **301** and **302**, and a separating insulating layer, such as layer **308**. However, embodiments containing the second insulating layer **309** and central conducting layer **307** have greater electrical stability during folding.

Figure 4A

The first electrically conductive fabric layer **301** is shown in more detail in *Figure 4A*. Two conductive tracks **311** and **312** form the electrical contacts with the conductive fibres of fabric layer **301**. A contacting portion **411** of conductive track **311** contacts the left edge of fabric layer **301**. A conduction portion **421** of conductive track **311** is channelled into the flexible cable **104** and prevented from contacting the electrically conductive fabric layer **301** by insulation strip **401** that runs along the upper edge of

fabric layer **301**, and shown as a shaded area in *Figure 4A*.

Similarly, the conductive track **312** contacts the electrically conductive fabric along the right edge of fabric layer **301** over a contacting portion **412**. A conduction portion **422** extends into flexible cable **104** and is prevented from contacting the electrically conductive fabric layer **301** by insulation strip **401** that runs along the upper edge of fabric layer **301**. This enables voltages to be applied between the conductive tracks **311** and **312** to provide a voltage gradient in the X axis direction.

Figure 4B

The second electrically conductive layer **302** is shown in more detail in *Figure 4B*. Electrical connection is formed with the fabric layer **302** by the two conductive tracks **313** and **314**. Conductive track **313** forms an electrical contact with the top edge of the electrically conductive fabric **301** via contacting portion **413**. A conduction portion **423** of conductive track **313** extends over insulation strip **402**, that extends along the top edge of the fabric layer, and enters the flexible cable **104**. Conductive track **314** forms an electrical connection with bottom edge of the fabric sheet **302** via its contacting portion **414**. A conduction portion **424** of conductive track **314** extends along the right edge of the fabric sheet and the top edge of the fabric sheet and enters into the flexible fabric cable **104**. The conduction portion **424** of conductive track **314** is electrically insulated from the fabric layer by insulating strip **402** which extends along the top edge and **403** which extends along the right edge of layer **302**.

Accordingly, voltages may be applied between the conductive tracks **313** and **314** so as to provide a voltage gradient across the electrically

conductive fabric layer **302** from top to bottom in the Y axis direction.

In this embodiment, only four connections are possible to the fabric keyboard, two connections to conductive tracks **311** and **312** of fabric layer **301**, and two connections to conductive tracks **313** and **314** of fabric layer

5 **302**.

Figure 5

The interface circuit **501** located in the computer receiving assembly **105** is detailed in *Figure 5*. The interface circuit comprises a peripheral interface controller (PIC) **502** which is connected to a serial communication output **503**, for connection to the computer **101**, and electrical connections **504**, **505**, **506** and **507** configured to supply and receive the necessary voltages to the conductive tracks **311**, **312**, **314** and **313** respectively.

The peripheral interface controller (PIC) **502** is a programmable controller of the type PIC16C711. The PIC **502** operates under the control of a programme which controls the parameters of the keyboard which the interface circuit **501** is configured to measure. Parameters under investigation will be discussed further in reference to *Figures 6A to 6D and 7 to 10*.

20 Under control of the PIC **502**, the necessary output voltages can be supplied to electrical connections **504**, **505**, **506** and **507** via pins one, two, ten, eleven, twelve and thirteen of the PIC. The PIC includes an analogue to digital converter which is used to process analogue voltages received at pins seventeen and eighteen. The input pins seventeen and eighteen receive outputs from high impedance buffers **508** and **509** respectively. The

25 buffers **508** and **509** are half of unity gain operational amplifiers of the type

TL062. The buffers **508** and **509** provide a high impedance buffer between the sensor output voltages received at connections **507** and **505**, and the PIC **502** input ports seventeen and eighteen respectively.

5 Connection to pins one and two occurs via resistors **510** and **511** respectively. Resistors **510** and **511** are selected according to the resistance of the keyboard as measured from a conducting track attached to one fabric layer **301** to a conducting track attached to the second fabric layer **302** while a typical mechanical interaction pressure, i.e. a key-press is applied. A value of ten Kohms is typical for resistors **510** and **511**.

10 The PIC **502** has an external crystal oscillator (not shown) running at four MHz connected across pins fifteen and sixteen. Positive four volts received from the computer **101** is supplied to pin fourteen and ground is connected to pin five. Pin four (the internal reset input) is held at positive four volts via a series resistor of one hundred ohms.

15 The PIC **502** is programmed to supply and receive the necessary voltages to the conductive tracks **311**, **312**, **314** and **313** of the conductive layers **301** and **302**. By this means the interface circuit is able to determine a measure, denoted by Z, of the pressure applied to the keyboard, and if this value is sufficiently large the interface circuit interprets this as a key-press. When a key-press is detected the interface circuit performs a measurement of the X and Y location of where the pressure is being applied. The PIC is further configured to supply data to the output serial port **503** relating to the position of key-presses detected or the absence of a key-press.

25 An overview of the measurements made by interface circuit **501** is illustrated by *Figures 6A, 6B, 6C and 6D*. The outer conductive layers **302**

and **301** are represented schematically by potentiometers **601** and **602** and the resistance of the conductive path between the outer layers at the location of the applied force is represented by variable resistor **603**.

5 **Figures 6A**

A first measurement is shown in *Figure 6A*. Four volts are applied to connector **504**, while connector **505** remains disconnected. Connector **507** is connected to ground via the resistor **511** of known value. Thus, current flows from connector **504** through a first part of layer **301** indicated by a first part **605** of potentiometer **602**, through the conductive path indicated by variable resistor **603** having resistance R_v , through a first part of layer **302**, indicated by a first part **606** of potentiometer **601** and through the known resistor **511**. The voltage, V_1 appearing at connector **507** is measured and since this is equal to the voltage drop across resistor **511**, V_1 is directly proportional to the current flowing from connector **504**.

10

15

Figure 6B

A second measurement is shown in *Figure 6B*. Four volts are applied to connector **506**, while connector **507** is disconnected. Connector **505** is connected to ground via the resistor **510** of known resistance. The voltage V_2 , dropped across resistor **510** is measured. Voltage V_2 is directly proportional to the current flowing through a second part of layer **302** indicated by a second part **608** of potentiometer **601**, through the conductive path indicated by variable resistor **603** having resistance R_v , through a second part of layer **301** indicated by a second part **609** of potentiometer **602** and through resistor **510**.

20

25

The sum of the resistance of first part **606** and second part **608** of potentiometer **601** is approximately equal to the resistance between contacting portions **413** and **414** on layer **302**, and is therefore substantially constant during the measurements, since they occur in rapid succession.

5 Similarly the sum of the resistance of first part **605** and second part **609** of potentiometer **602** is approximately equal to the resistance between contacting portions **311** and **312** on layer **301**, and is also substantially constant during the measurements. As a result, the relationship **610** exists between the resistance R_v , of the conductive path between the outer

10 layers, and the measured voltages V_1 and V_2 . i.e. the resistance R_v between the outer layers is proportional to the sum of the reciprocal of voltage V_1 and the reciprocal of voltage V_2 .

In general, depending upon the type of position sensor used, the resistance R_v depends upon area of the applied pressure or a function of

15 the area and the force as illustrated by relationship **611**. Thus, from the voltage measurements V_1 and V_2 a measure which is dependent on the force applied to the keyboard is determined.

Figure 6C

20 A third measurement is shown in *Figure 6C*. Four volts is applied to connector **505** while connector **504** is grounded, and so a potential gradient is produced across layer **301**. A voltage measurement is made at connector **507**. Since the interface circuit makes use of the high impedance buffer **508**, the voltage appearing on layer **302** at the position of the applied force is

25 determined. This voltage, V_3 is directly proportional to the distance of the centre of the applied force from contacting portion **311** and indicates its X

axis position.

Figure 6D

A fourth measurement is shown in *Figure 6D*. Four volts are applied to connector **507** and connector **506** is grounded. A voltage measurement is made of voltage V4 appearing at connector **505**. Voltage V4 is directly proportional to the distance of the centre of the applied force from contacting portion **414** and indicates its Y axis position. Therefore, voltage V3 and V4 provide information as to the two dimensional position of the applied force on the sensor **106**. i.e. voltages V3 and V4 represent X and Y values for the centre of the position of the applied force, representing a key-press.

Figure 7

The program running within the peripheral interface circuit of *Figure 5* is outlined in the flow chart of *Figure 7*. The computer **101** is switched on at step **700** and power is supplied to the interface circuit. At step **701** the hardware is initialised and an initial message is sent to the computer **101** via the serial output port. This process is detailed later with reference to *Figure 18*. At step **702** a question is asked as to whether the last data sent to the computer **101** was 0,0, i.e. X=0 and Y=0. During operation of the keyboard, the interface circuit sends positional data to the computer **101** in the form of two eight bit binary numbers, i.e. two numbers of value between zero and **255** (decimal). However, there are no key positions corresponding to 0,0 and the use of these zero values is reserved to indicate to the computer **101** that the keyboard is not being pressed. On the first occasion of entering step **702** the question is answered in the affirmative and so step **703** is entered where

a Z value is measured. The Z value is dependent on the force being applied to the keyboard, and so provides an indication as to whether the keyboard is being pressed. At step **704**, the measured Z value from step **703** is compared with a predetermined threshold value, and if the measured Z value is equal to or greater than the threshold value, indicating a key-press, step **705** is entered. Alternatively, if the Z value is too small, the process returns to step **702**. At step **705**, X and Y positional values of the press applied to the keyboard are measured and stored as temporary variables X1 and Y1. At step **706** the Z value is re-measured, by essentially the same process as step **703**. At step **707**, the Z value from step **706** is compared with the aforementioned threshold value, and as in step **704** if the Z value is less than the threshold value, step **702** is re-entered. But, if the measured Z is greater or equal to the threshold value step **708** is performed. At step **708**, X and Y position values are re-measured and stored as X2 and Y2, by a similar process to that at step **705**. The Z value is then measured again at step **709**, by the same process as at step **703**, and compared with the threshold value at step **710**. Once again, step **702** is re-entered if the Z value has fallen below the threshold value. If the Z value is still equal to or greater than the threshold, step **711** is entered. Therefore, step **711** is only entered when the interface circuit has measured two consecutive sets of X and Y values such that the Z values measured immediately before and after each set of X and Y values is greater than or equal to a predetermined threshold value. Consequently, the stored X1, Y1 and X2, Y2 values carried forward to step **711**, are likely to be the result of intended presses on the keyboard, and they are therefore treated as such by the process.

At step **711** a question is asked as to whether X1 is equal to X2 plus or minus two, and Y1 is equal to Y2 plus or minus two. If the answer to this question is "yes", the measured positional data is regarded as stable and step **712A** is entered. Otherwise step **712B** is entered where the stored X2 value is stored as X1, and the stored Y2 value is stored as Y1, before the process returns to step **706**. Thus, if the positional data is not regarded as stable, as determined by step **711**, the process attempts to repeat steps **706** to **710** to acquire a new set of positional X,Y data values.

When the positional data is regarded at step **711** as stable, step **712A** is entered which is essentially the same as step **712B** in that the stored X2 and Y2 values are stored as X1 and Y1 respectively. However, from step **712A** the process enters step **713** where a question is asked as to whether either of the stored X1 or Y1 values differ from the last sent data values by 5 or more. For example, if the last sent data values were **48,174**, then at step **713** it is ascertained as to whether X1 is less than **44** or greater than **52**, or if Y1 is less than **170** or greater than **178**. If the answer to either of the questions is yes then step **714** is entered. Otherwise the process returns to step **706**. Therefore, step **714** is only entered if one, or both, of the present positional values is different to the last data sent, and then, at step **714**, said present position values, X1 and Y1 are sent to the computer **101** via the output port and stored as the last data sent.

Thus, positional values are only sent when they differ from the previously sent data values by more than a predetermined amount. This means that if a user keeps their finger pressing on a particular key, the PIC only sends data relating to the position of that key once. By this means, the computer's processor is saved from receiving repeated redundant positional

data. However, if a first key is pressed and a different second key is pressed before the first is released, this may give rise to two (or more) sets of positional data being sent to the computer consecutively. Typically, during typing, a first key is pressed an instant before a second key and the first to be pressed is also the first to be released. As a result, a moment of stability exists in the period between the two key presses and a second moment of stability exists in the period between the two key releases. Provided these two moments of stability are sufficiently long, the PIC detects the stability in the X and Y values it measures and sends positional data to the computer **101** corresponding to each of the two keys pressed. Between the second key being pressed and the first key being released, the interface circuit receives voltages which imply that positions between the actual two keys are being pressed. It is likely that these positions will be found to be variable one from the next and so regarded as unstable by the PIC at step **711**. However, it is possible that during such overlapping key presses, data relating to an intermediate position between the two keys might be sent to the computer **101**. It is therefore, a requirement of the further processing performed by the computer **101** to recognise this as only two key presses. This will be explained further with respect to *Figure 13*.

As an example, suppose the "G" key is pressed, then a moment later the "L" key is pressed, the "G" key is released and then the "L" key released. The interface circuit measures stable positional values relating to the "G" key and sends corresponding data to the computer **101**. It may then measure stable positional values relating to any of the keys positioned between "G" and "L" and send corresponding data, before it measures stable positional values relating to the "L" key and sends data corresponding to its position.

Having sent data at step **714** the process then returns to step **706**. In the event that the keyboard is no longer being pressed when the Z value is measured at steps **706** or **709**, the question asked at step **707** or **710** will be answered in the negative and the process returned to step **702**. At step **702**,
5 if the last data sent to the computer **101** was positional data corresponding to a pressed key, the question will be answered negatively and step **715** will be entered. At step **715** the data 0,0 is sent to the computer **101** to indicate the absence of a key-press and 0,0 is stored as the last data sent. Following step **715**, step **703** is entered and the process continues as previously described.

10 In summary of the program running within the PIC, it defines a process in which positions of mechanical interactions, corresponding to key-presses, are measured and where said positions are found to be momentarily stable, positional data relating to those stable positions is sent to the computer **101**. However, the data is only sent if it is different to the most recent data sent by
15 a predetermined amount. In addition, in the event that the keyboard stops being pressed, a second data type, in this case the data 0,0, is sent to the computer **101** to indicate the absence of a key-press.

It should now be understood, that when single keys are pressed individually, the data which is sent to the computer **101** is the 0,0 data
20 relating to the absence of a key-press, followed by positional data, followed by 0,0 data as the key is released. Also, when two keys are pressed in the aforementioned overlapping manner, the data which is sent to computer **101** is the 0,0 data, followed by two or more sets of positional data, followed by 0,0 data.

Figure 8

Step **701** of *Figure 7* is shown in further detail in *Figure 8*. Within the initialisation step **701**, at step **801** the interrupts are cleared and then at step **802** pins seventeen and eighteen of the PIC are set up as analogue to digital converter inputs. The micro ports of a PIC16C711 may be configured as low impedance outputs or high impedance inputs, and when in high impedance input mode, pins seventeen and eighteen can be programmed to connect via an internal multiplexer, to the analogue to digital converter. At step **803** the ports which are to be used as inputs or outputs are configured in their initial state. Therefore, pins eighteen, seventeen, one, two, ten, eleven, twelve and thirteen are configured as high impedance inputs while pin seven is configured as a low impedance output. At step **804** all system variables are cleared and all interrupts are disabled. At step **805** an initial message is sent to the computer **101** confirming the presence of the keyboard **102**. In response, the computer **101** will then run the keyboard application so that data received from the keyboard is correctly processed. In addition, the data 0,0 is sent to the computer **101** indicating that no keys are presently being pressed on the keyboard.

Figure 9

Step **703** of *Figure 7* is shown in further detail in *Figure 9*. Within step **703**, at step **901**, the ports corresponding to pins two and ten are reconfigured as low impedance output ports and at step **902** pin two is set to zero volts while pin ten is set to positive four volts. Thus, connector **507** is grounded via resistor **511** and four volts are applied to connector **504**. At step **903** a time delay, (typically of **200** microseconds in a sensor

measuring 90 millimetres by 240 millimetres with an outer layer resistance of 3.5Kohms) is provided to allow voltages to settle before the voltage at pin seventeen is measured and stored. Thus, voltage V1 present at connector 507 is measured and stored as temporary variable V1.

5 At step 905 pins two and ten are reconfigured as high impedance inputs while pins one and twelve are reconfigured as low impedance outputs. At step 906 the voltages on pins one and twelve are set to zero and positive four volts respectively. Thus, connector 505 is grounded via resistor 510 while four volts are supplied to connector 506. A suitable time
10 delay, equivalent to that at step 903, is provided at step 907 before the voltage at pin eighteen is measured and stored at step 908. Thus, the voltage present on connector 505 is measured and stored as temporary variable V2. At step 909, a Z value is calculated from stored voltages V1 and V2, as $1/((1/V1)+(1/V2))$ and it is then stored. The pins one and twelve
15 are reconfigured back to their initial state of high impedance inputs at step 910.

Figure 10

Step 705 of Figure 7 is shown in further detail in Figure 10. Within
20 step 705, at step 1001 pins one and two are reconfigured as high impedance inputs and pins ten and eleven as low impedance outputs. At step 1002 pin ten is set to zero volts and pin eleven is set to positive four volts. Thus, four volts are supplied to connector 505 while connector 504 is grounded. A delay is then provided at step 1003, (of typically 200
25 microseconds for a sensor measuring 90mm by 240mm) to allow voltages in the sensor to settle before the voltage on pin seventeen is measured at

step 1004. Therefore a voltage V3 present on connector 507 is measured which provides an indication of the X position of the applied force. The measured value is stored as X1.

Pins ten and eleven are then reconfigured as high impedance inputs and pins twelve and thirteen are reconfigured as low impedance outputs at step 1005. The voltage on pin twelve is then set to zero while the voltage on pin thirteen is set to four volts at step 1006. Thus, four volts are supplied to connector 507 while connector 506 is grounded. A time delay is provided at step 1007, similar to that at step 1003, before the voltage appearing at pin eighteen is measured at step 1008. Thus, a voltage V4 present on connector 505 is measured which provides an indication of the Y position of the applied force, and stored as temporary variable Y1. Pins twelve and thirteen are then reconfigured back to their initial state of high impedance inputs at step 1009.

15

Figure 11

A rear view of Palm 101 is shown in *Figure 11*. The rear of the computer 101 includes ten electrical connections referred to as pins, such as pins 1102, 1103 and 1110. Pin 1102 provides approximately four volts to the interface circuit through a 330 Ohm resistor within the computer 101. From the computer's perspective, pin 1103 is the receive data connection, therefore data from interface circuit 501 is supplied to this pin. Signal ground is provided by pin 1110 and for this particular application the remaining pins are not used.

25

Figure 12

A schematic view of computer **101** is shown in *Figure 12*. The computer includes a power supply **1201** comprising rechargeable batteries. The batteries conventionally supply electrical power to various components of the computer, but in this embodiment they also supply power to the interface circuit **501** through the computer's pins **1102** and **1110** as mentioned above. The computer further comprises a processor **1202** which is in communication with the computer's touch sensitive display **103**, the computer's hardware buttons **1203** and memory **1204**. Amongst other functions, the processor **1202** runs the keyboard application program resident in the memory **1204**, which was downloaded in a "Hotsync" process as previously described. When running the keyboard application, the processor receives data sent by the interface circuit **501** via pin **1103** and processes the received data to generate display data representing characters such as letters and numbers, which it then stores in a keyboard buffer for display on the LCD display **103**.

Figure 13

The keyboard application program running in the computer **101** is illustrated by the flow chart of *Figure 13*. Following the computer being switched on at step **1301** it receives the initial message sent by the PIC **502**, as identified at step **805** on *Figure 8*. At step **1302** the computer **101** receives the initial message, then at step **1303** the computer's operating system starts the keyboard application. At step **1304** the initial data 0,0 sent by the PIC, as identified at step **805**, is received and at step **1305** the received data is looked up in a table where corresponding character data, is

retrieved and stored as both temporary variables "present character" and "last character sent". Where the received data relates to the position of an interaction with the keyboard, i.e. a key-press, the character data retrievable from the look up table corresponds to data recognised by the computer to display characters such as letters, numbers and brackets or perform typing functions such as "shift", "backspace", "control", "return", etc. However, in this instance, the received data is 0,0, and so the data retrieved from the table corresponds to the null character, rather than a display related character.

At step **1306** data stored as "present character" is stored as the temporary variable "last character received". So, in the first instance of entering step **1306**, the null character is stored as "last character received", and, as always, the value of "last character received" relates to the last data received from the PIC.

At step **1307** the processor waits to receive more data from the interface circuit before entering step **1308** where the newly received data is looked up in the look up table, and new character data is retrieved and stored as "present character". At step **1309**, a question is asked as to whether "last character received" is the null character and "present character" is not the null character. If the question is answered yes, as it will be in the first instance of a key-press, step **1310** is entered where the data stored as "present character" is sent to the keyboard buffer for display purposes. In addition, the data stored as "present character" is stored as "last character sent". Thus, the last character sent to the keyboard buffer is recorded.

The process then re-enters **1306** where the data stored as “present character” is also stored as “last character received”. The processor then waits for the receipt of further data at step **1307** before repeating steps **1308** and **1309**.

5 The second time step **1309** is entered is an example of when the question will be answered in the negative, since the “last character received” is no longer the null character. If the question at step **1309** is answered “no” then step **1311** is entered where a question is asked as to whether “last character received” is not the null character and “present
10 character” is the null character. If this question is answered negatively, the process returns to step **1306** and steps **1306** to **1309** are repeated. This would occur if both “last character received” and “present character” correspond to positional data received from the PIC, as would happen during the aforementioned overlapping key-presses.

15 If the question asked at step **1311** is answered in the affirmative, then step **1312** is entered. This situation corresponds to the release of a key leaving the keyboard with no keys pressed. Said released key could have been an individually pressed key or the second of two keys in an overlapping key-press. At step **1312** a further question is asked as to
20 whether “last character received” is the same as “last character sent”. In the case of a single key being individually pressed and released, the answer to this question will be “yes”, and the process returns to step **1306**. However, in the case of an overlapping key-press the answer to this question will be “no”, resulting in “last character received” being sent to the keyboard buffer
25 at step **1313**, and “present character” being stored as “last character sent”. The process then returns to **1306**.

By this process, the computer's processor is able to receive data relating to individual key-presses and generate data corresponding to a single character. It is also able to receive data relating to two overlapping key-presses and generate data for the corresponding two characters.

5 In the above described embodiment the processing of the signals received from the keyboard sensor, i.e. from the conducting layer **301** and **302**, is performed by the PIC and further by the processor located within the computer. However, in an alternative embodiment, the process described with respect to *Figure 13* is performed by the PIC in interface circuit **501**,
10 along with the process of *Figure 7*. Thus, the computer is supplied with data which it recognises as originating from a keyboard and corresponding to characters for display on its LCD **103**. The processing workload of the computer may thus be reduced. This embodiment is more appropriate where the processing power of the computer is more limited.

15 In another alternative embodiment, a similar process to that described with respect to *Figure 13* is performed by the PIC in interface circuit **501**, along with the process of *Figure 7*. However, in this embodiment the keyboard **102** is connected to a serial input port of a mobile phone and the PIC is configured to send AT commands to the
20 phone in response to key-presses. By this means, a user is able to enter text to the phone for, for example, Short Message Service (SMS) messages.

Figure 14

25 A photocopier **1401** providing a further alternative embodiment of the present invention is shown in *Figure 14*. The photocopier is arranged to

receive original documents via feeder **1402**, and under manual instructions input at touch screen **1403**, produce photocopies which are delivered at collating trays **1404**. The rectangular touch screen **1403** displays an array of keys representing numerals and a variety of functions. Thus, for example, a user may select the number of copies for print by pressing the corresponding number keys, and select paper size, enlargement ratio, collating requirements etc. by pressing the function key followed by number keys where necessary. The touch screen therefore provides a replacement for a conventional keyboard with hardware buttons or keys.

10

Figure 15

The touch sensitive screen **1403** and a micro-controller **1501** located in the photocopier **1401** are shown schematically in *Figure 15*. The micro-controller **1501** is in communication with a memory device **1502**, along with various transducers (not shown) located within the photocopier and necessary for its operation.

15

The touch sensitive screen **1403** includes a liquid crystal display **1503** which has a glass sheet **1504** as its uppermost layer. The glass sheet **1504** has an electrically conductive transparent coating applied to its upper surface. This is then held parallel to a transparent plastic sheet **1505** having an electrically conductive transparent coating on its lower surface. The two sheets **1504** and **1505** are held very close together and a small mechanical pressure, such as produced by a user's finger applied to upper sheet **1505**, results in electrical contact being made between the two sheets. The plastic sheet **1505** has highly conductive tracks **1506** and **1507** located along its two shorter opposing edges and in contact with the conductive coating.

20

25

These conductive tracks **1506** and **1507** are connected to input/output ports of the controller **1501**. Thus, the controller is able to apply a voltage across the conductive layer on the upper sheet. In a similar manner a pair of highly conductive tracks **1508** and **1509** are located on the lower conductive coating adjacent to the opposing longer edges of the sheet **1504**. These tracks **1508** and **1509** are also connected to input/output ports of the micro-controller.

The memory device **1502** contains operating instructions which the micro-controller accesses and executes. Amongst other things, the operating instructions include those for supplying voltages to the touch screen's conducting tracks **1506** to **1509** and for processing signals received from said tracks. Operating under said instructions the processor performs processes analogous to those described with reference to *Figures 7 to 10* and *13*, and hence is able to interpret signals received from the touch sensitive screen **1403** as key-presses of a keyboard. In particular, it is able to receive signals produced from overlapping key-presses and generate data corresponding to two typed characters.

In an alternative embodiment, the photocopier includes a second controller which performs the functions carried out by the PIC **501** in the first embodiment. Thus, the two controllers in the photocopier co-operate in a similar manner to the PIC **501** and processor **1202**.

Like the first described embodiment, only four connections are possible to the touch sensor of the photocopier **1401**, two connections to conductive tracks **1506** and **1507** of layer **1505**, and two connections to conductive tracks **1508** and **1509** of layer **1504**.

In a further alternative embodiment, a personal computer (PC) is connected to a monitor with a capacitive touch sensitive screen. An example of a suitable touch sensitive monitor is presently supplied by Farnell Electronic Components Limited, of Leeds, U.K, as a 15" XGA
5 Capacitive Touch monitor, LMU-TK15AT. The touch sensitive monitor provides serial data to the PC, comprising XY positional data relating to where it is being touched and other data identifying the absence of a touch. Application software allowing the PC to receive and interpret the signals from the touch sensitive device are installed on its hard drive.

10 When the touch sensitive device is used, the PC's processor runs the application software which performs a similar process to that detailed earlier in respect of *Figure 13*. Thus, for example, it is possible for the PC to display an array of buttons on the touch sensitive screen of its monitor and the application software allows a user to select a button by touching the
15 screen at the correct position. Moreover, the PC is able to correctly identify two pressed keys when the user makes overlapping "key-presses" to the touch sensitive screen in the manner previously described.

It may be seen from the above embodiments, that the process for generating characters from overlapping key-presses is applicable to many
20 alternative data processing apparatuses, where positional data is derived from a single positional sensor, which is used to simulate actions of a keyboard. Furthermore, many types of sensor, such as fabric and non-fabric resistive touch sensors, and capacitive touch sensors, are capable of supplying the data required by the data processing apparatus.

Claims

1. Data processing apparatus configured to receive signals from an input sensor arranged to duplicate or replace operations of a keyboard, said signals corresponding to positions of mechanical interactions with said sensor, said apparatus comprising:

processing means configured to process data derived from said input sensor including positional data corresponding to the position of a mechanical interaction with said input sensor and a second data type corresponding to the absence of a mechanical interaction with said input sensor, wherein said processing means is configured to generate data representing a first character in response to processing an item of data of said second type followed by positional data corresponding to a first position, and to generate data representing a different second character in response to processing positional data corresponding to a different second position followed by an item of data of said second type.

2. Data processing apparatus according to claim 1, wherein said input sensor comprises a first conducting layer and a second conducting layer, each of said conducting layers having a conductive track positioned along opposing edges, and said data processing apparatus is configured to apply a voltage between said conductive tracks of said first layer and to measure the voltage appearing at a conductive track of said second layer to determine said positional data.

3. Data processing apparatus according to claim 1 or claim 2, wherein said processing means is configured to:

(a) perform a first measurement relating to the position of a mechanical interaction with said sensor to generate a first measurement value;

(b) perform a second measurement relating to the position of said mechanical interaction to generate second value; and

(c) generate said positional data only when said first value is within a predetermined amount of said second value.

4. Data processing apparatus according to any of claims 1 to 3, wherein said sensor is an XY position sensor, and said positional data corresponds to the position within a continuous area defined by said sensor.

5. Data processing apparatus according to any of claims 1 to 4, wherein said processing means is configured to measure a parameter of said sensor relating to the pressure applied to said sensor.

6. Data processing apparatus according to claim 5, wherein said positional data is generated by said processing means only when said measured parameter exceeds a predetermined amount.

7. Data processing apparatus according to any of claims 1 to 6, wherein said data processing apparatus comprises a hand-held computer.

8. Data processing apparatus according to any of claims **1** to **7**, wherein said processing means comprises two processing devices, such that:

5 one of said processing devices is configured to receive said signals from said input sensor and to generate said positional data and data of said second data type; and

 the second of said processing devices is configured to process said positional data and data of said second data type to generate data
10 corresponding to displayable characters.

9. Data processing apparatus according to claim **8**, wherein second processing device is located in a computer.

15 **10.** Data processing apparatus according to any of claim **8** or **9**, wherein said first processing device forms part of a keyboard assembly.

11. Data processing apparatus according to any of claims **8** to **10**, wherein said first processing device is configured to generate a stream of
20 data comprising positional data, and to send positional data to said second processing device only when an item of positional data differs from the immediately preceding item of sent data by more than a predetermined amount.

25 **12.** Data processing apparatus according to any of claims **1** to **11**, wherein said input sensor forms part of said data processing apparatus,

and said input sensor comprises at least two layers of conductive fabric.

13. A method of processing signals received from an input sensor arranged to replace operations of a keyboard, said signals corresponding to positions of mechanical interactions with said sensor, wherein said method
5 comprises:

processing data derived from said signals, said data comprising positional data corresponding to the position of a mechanical interaction with said input sensor and a second data type corresponding to the
10 absence of a mechanical interaction with said input sensor, such that data representing a first character is generated in response to processing an item of data of said second type followed by positional data corresponding to a first position, and data representing a different second character is generated in response to processing positional data corresponding to a
15 different second position followed by an item of data of said second type.

14. A method of processing signals according to claim **13**, wherein said input sensor comprises a first conducting layer and a second conducting layer, each of said conducting layers having a conductive track
20 positioned along opposing edges, and said data processing apparatus is configured to apply a voltage between said conductive tracks of said first layer and to measure the voltage appearing at a conductive track of said second layer to determine said positional data.

15. A method of processing signals according to claim **13** or claim
25 **14**, wherein said method includes the steps of:

(a) performing a first measurement relating to the position of a mechanical interaction with said sensor to generate a first measurement value;

5 (b) performing a second measurement relating to the position of said mechanical interaction to generate second value; and

(c) generating said positional data only when said first value is within a predetermined amount of said second value.

10 **16.** A method of processing signals received from an input sensor according to any of claims **13** to **15**, wherein said sensor is an XY position sensor, and said positional data corresponds to the position within a continuous area defined by said sensor.

15 **17.** A method of processing signals received from an input sensor according to any of claims **13** to **16**, wherein a parameter of said sensor relating to the pressure applied to said sensor is measured, and said positional data is generated by only when said parameter exceeds a predetermined amount.

20 **18.** A method of processing signals received from an input sensor according to any of claims **13** to **17**, wherein a stream of data comprising positional data is generated, and an item of positional data is processed to generate data representing a character only when said item of positional data differs from the immediately preceding item of data in said stream by
25 more than a predetermined amount.

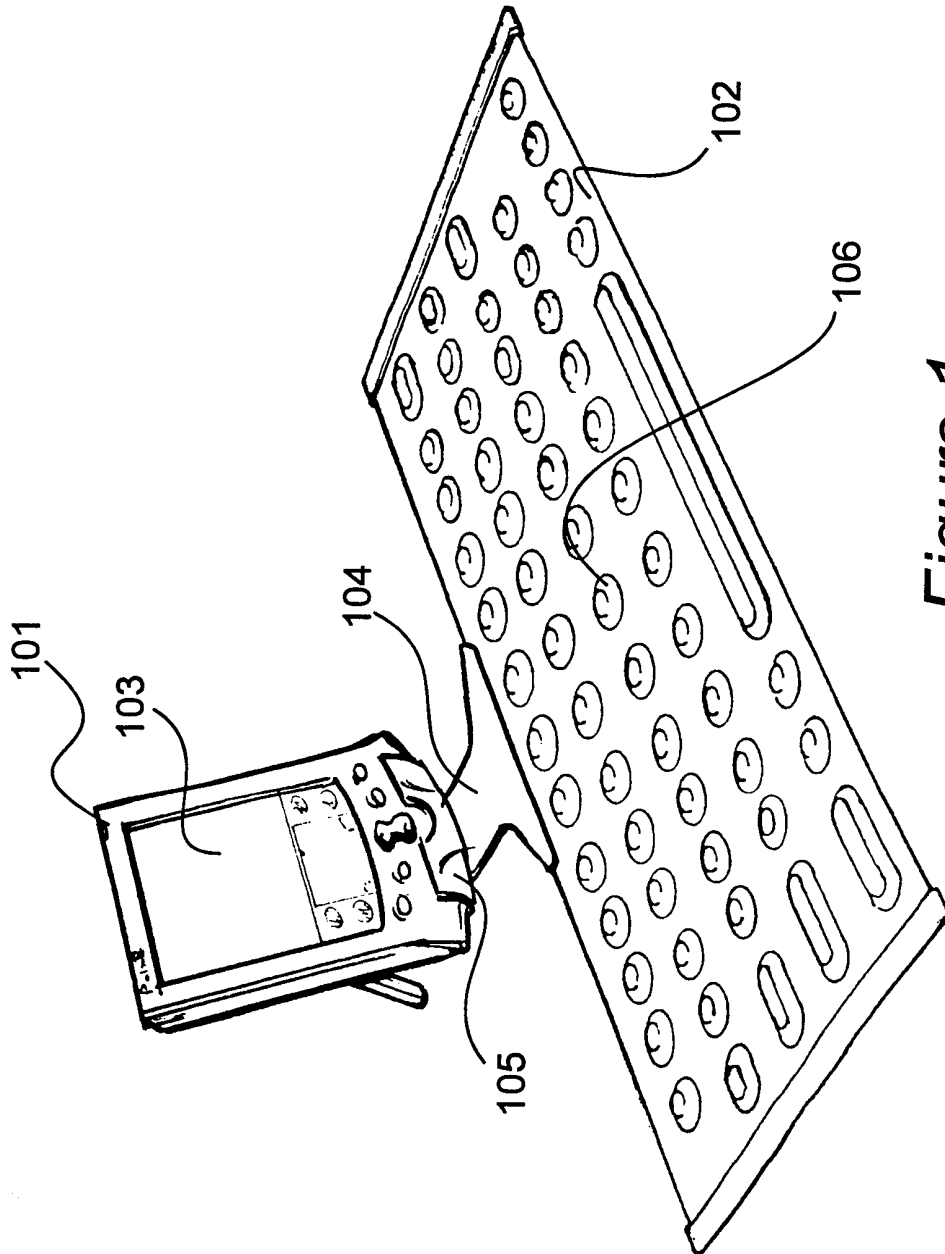

Figure 1

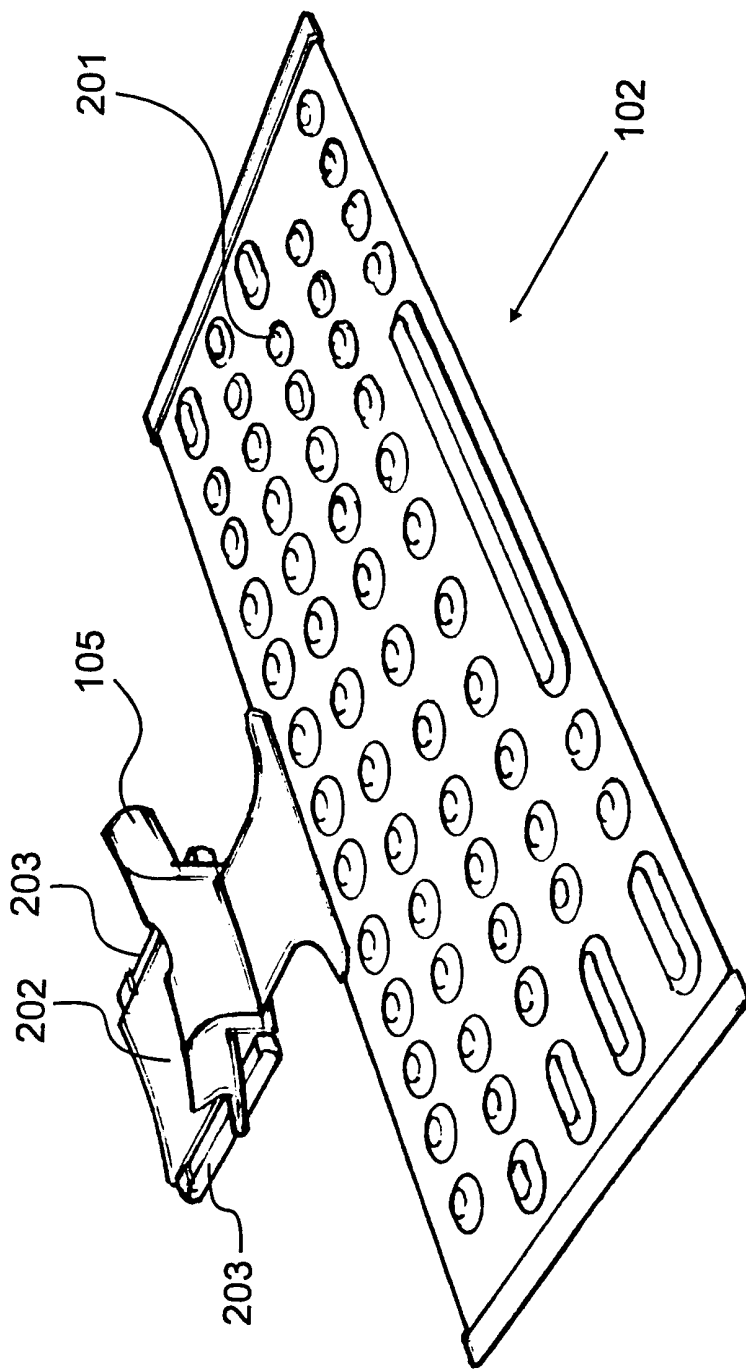

Figure 2

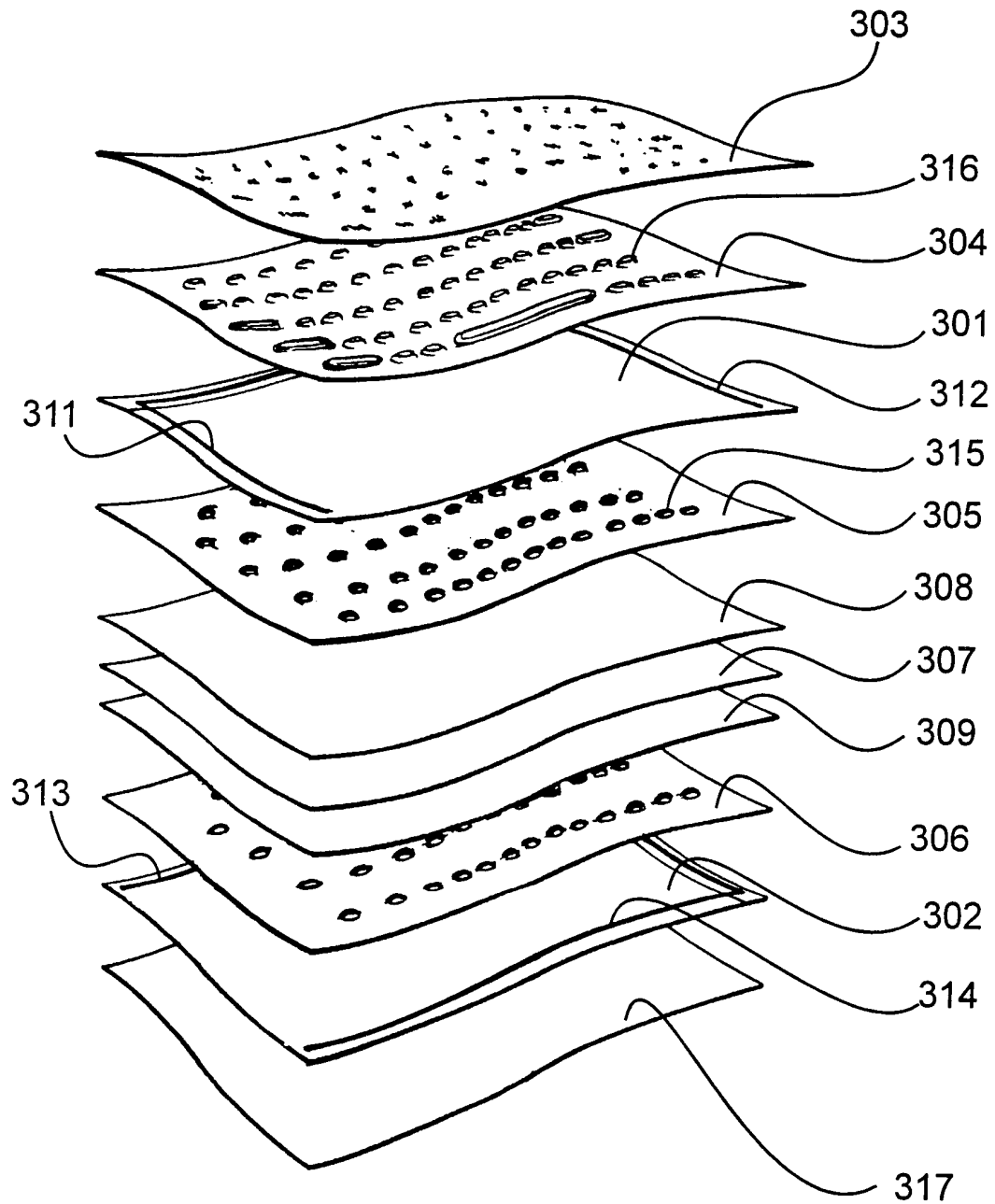

Figure 3

4/15

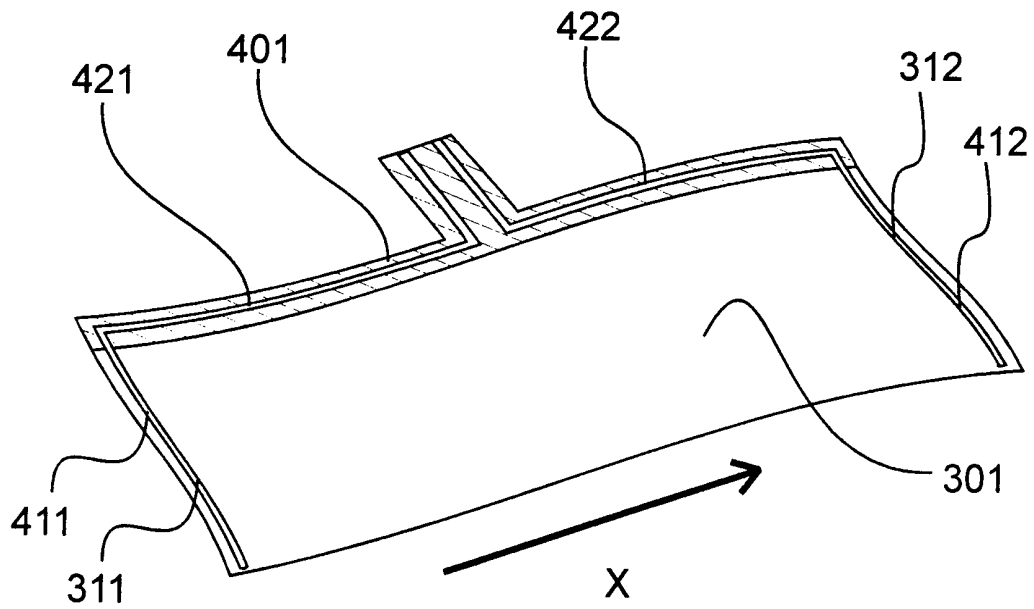

Figure 4A

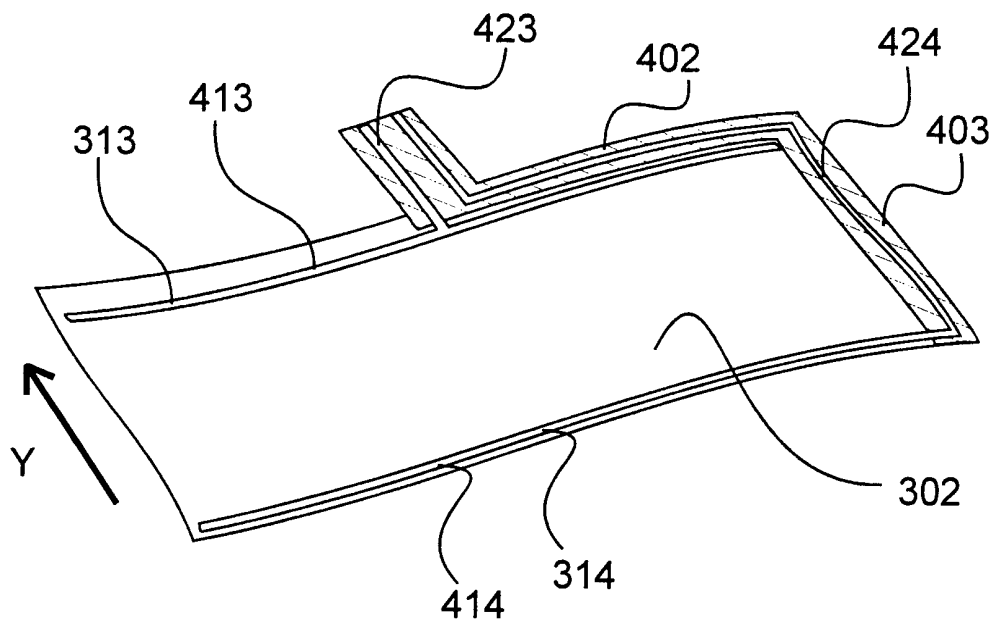

Figure 4B

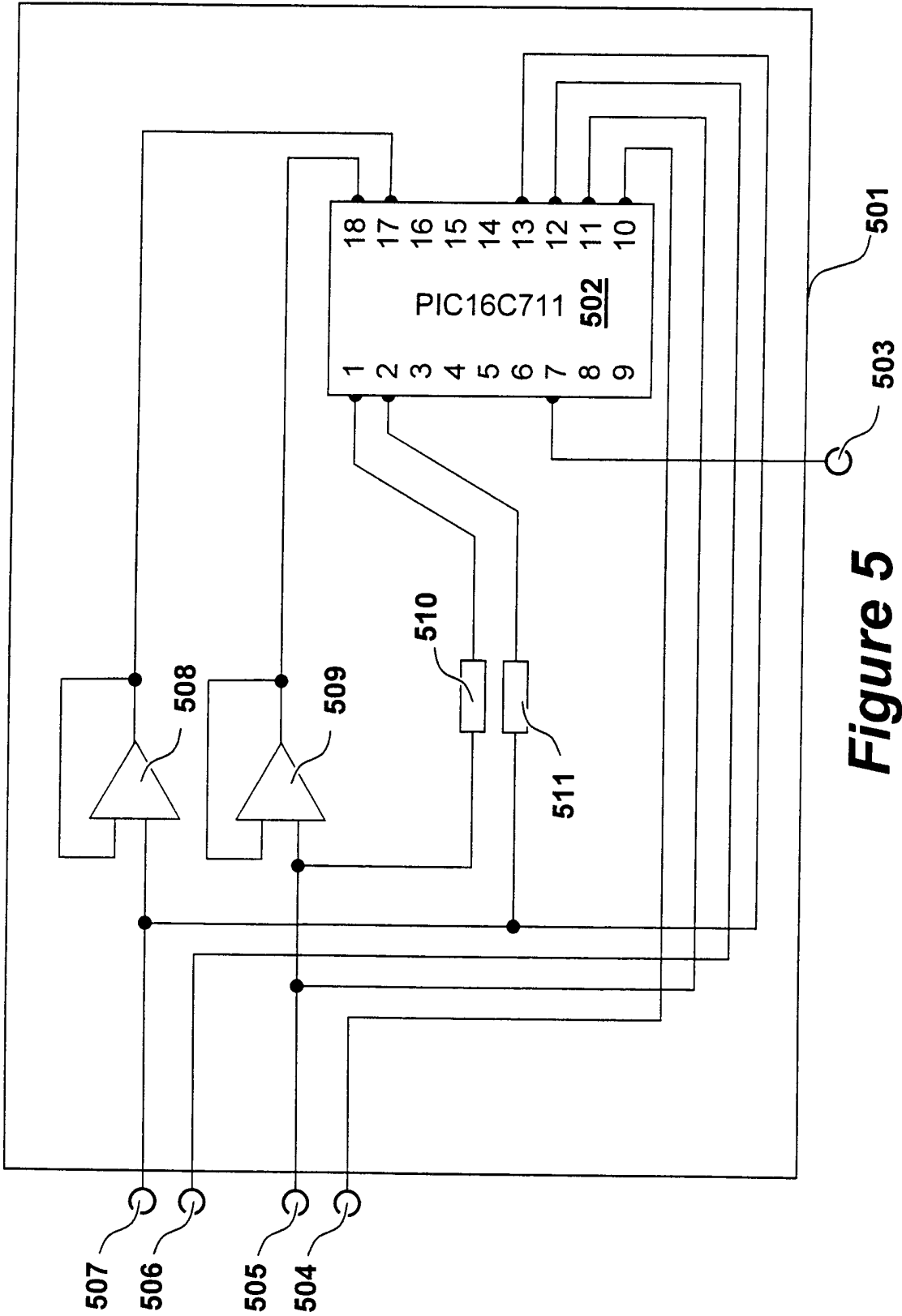

Figure 5

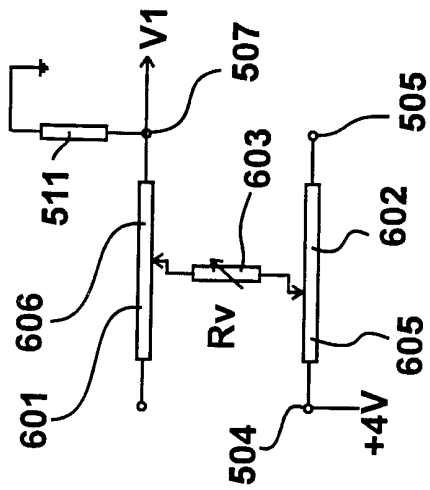

Figure 6A

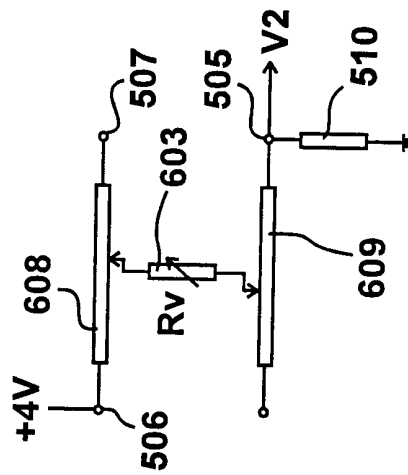

Figure 6B

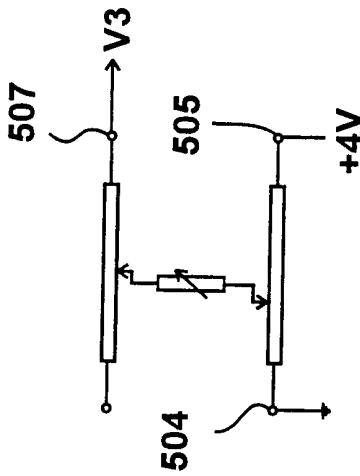

Figure 6C

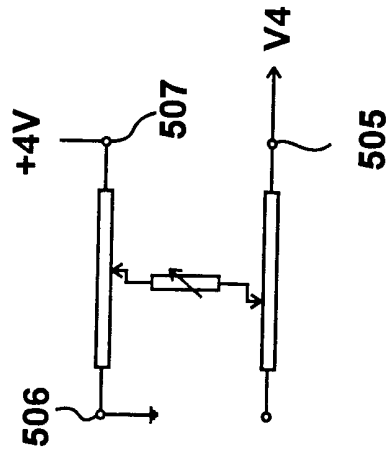

Figure 6D

$$Rv \propto \frac{1}{V_1} + \frac{1}{V_2}$$

$$\frac{1}{Rv} \sim \propto \text{AREA.FORCE}$$

611

7/15

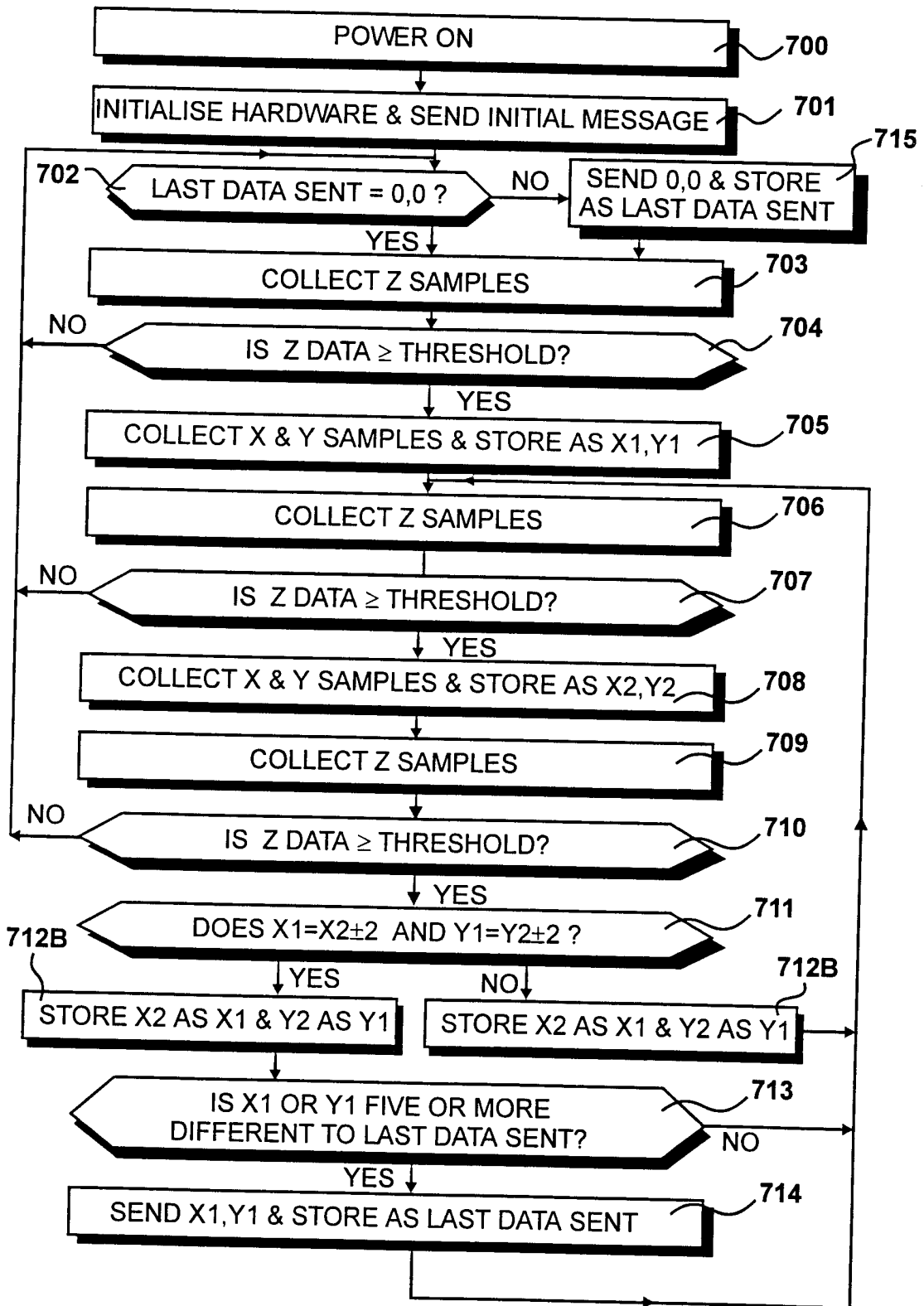

Figure 7

8/15

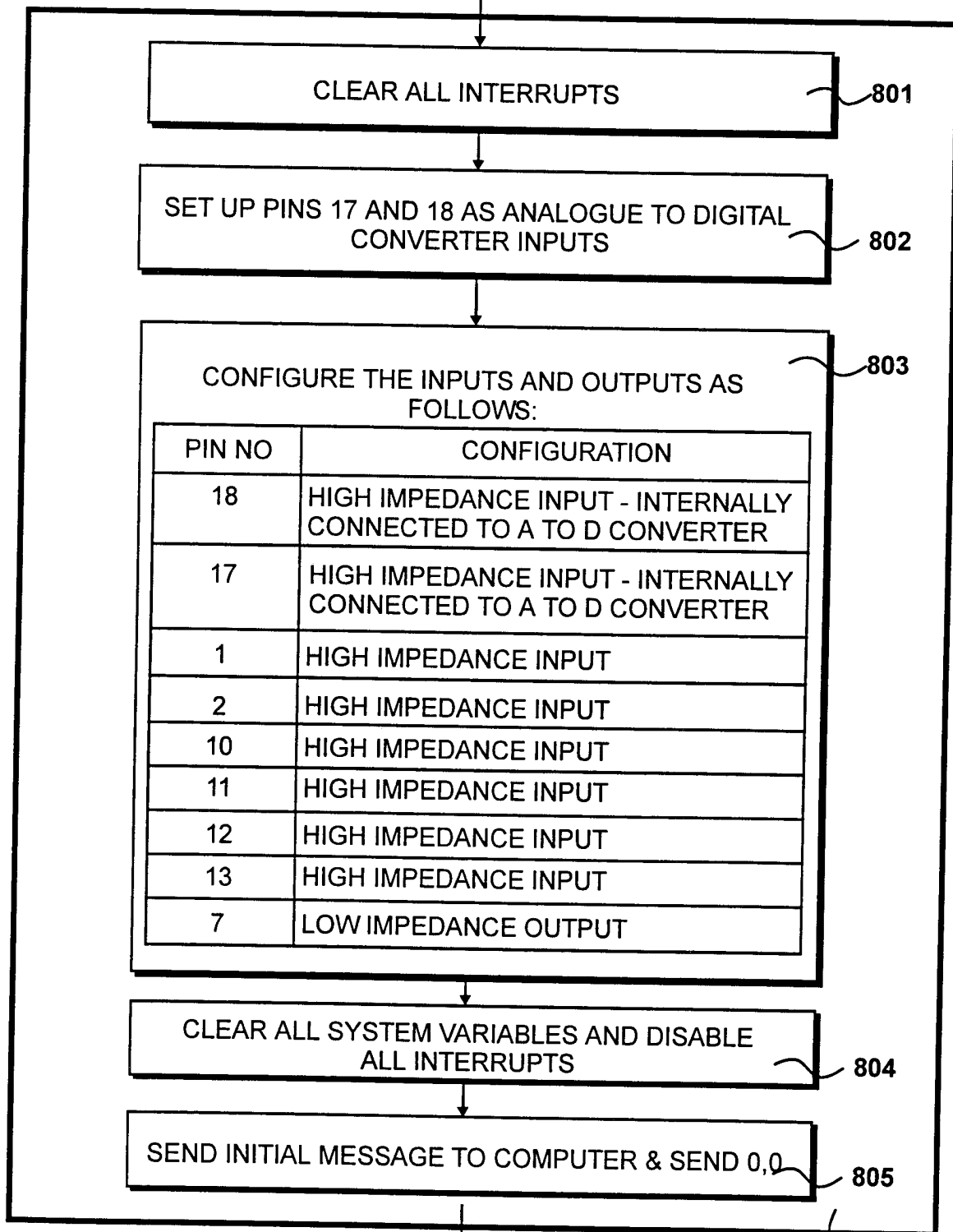

Figure 8

701

9/15

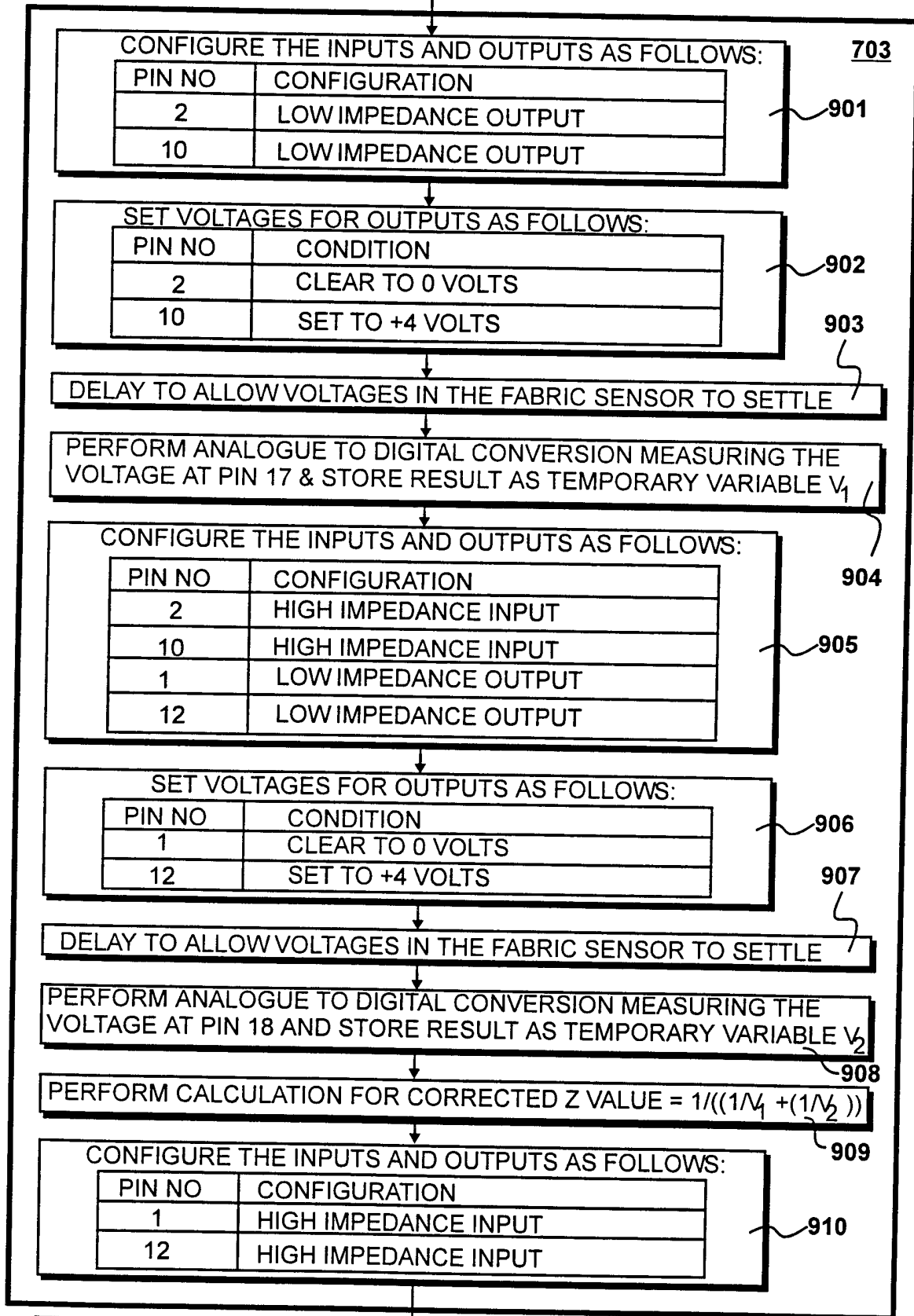

Figure 9

10/15

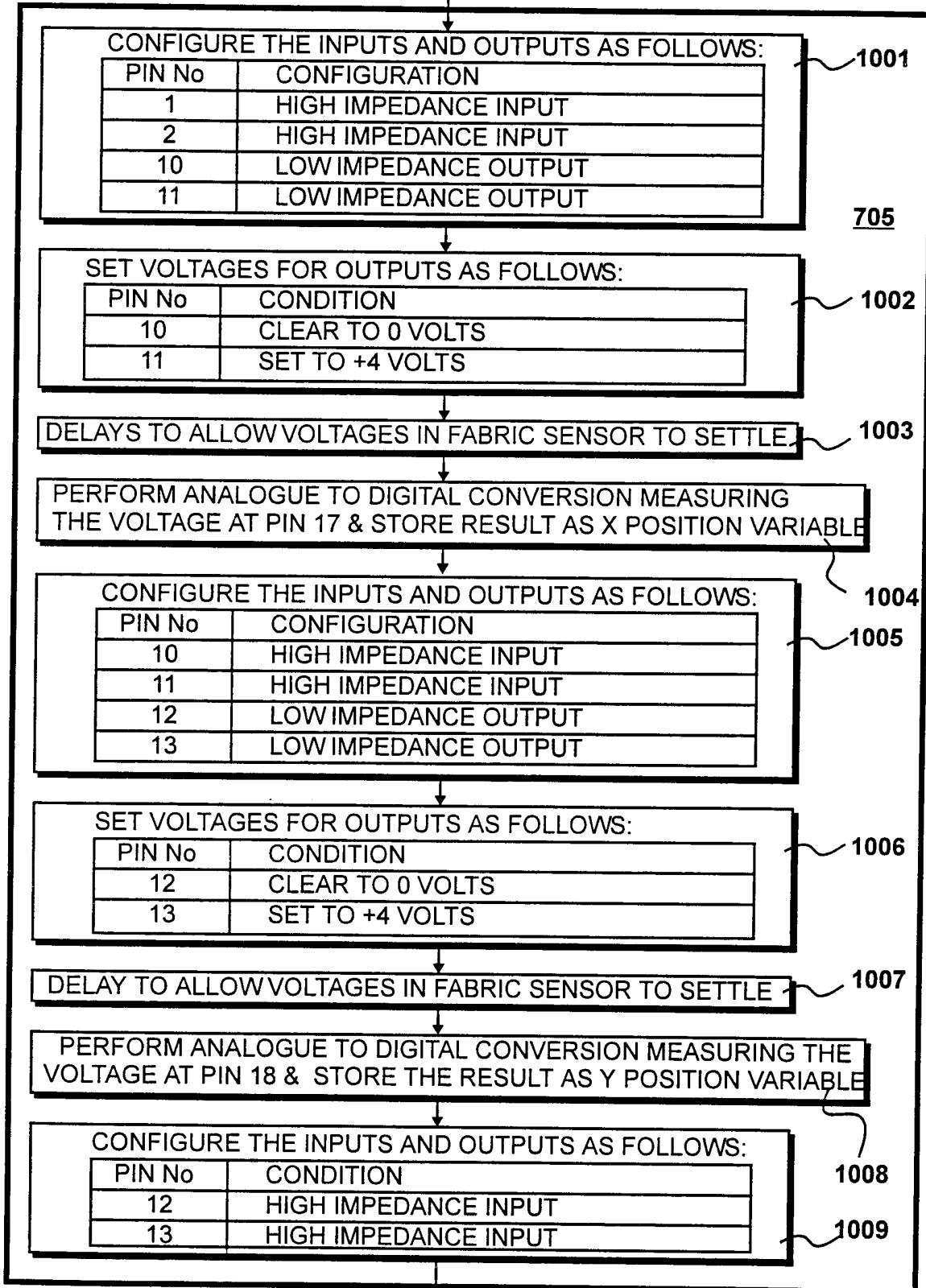

Figure 10

11/15

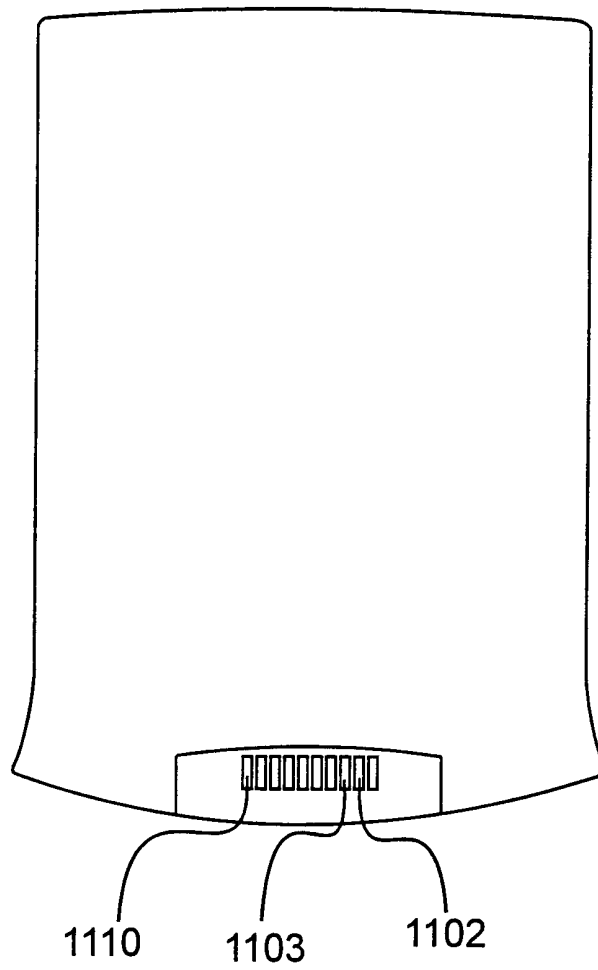

Figure 11

12/15

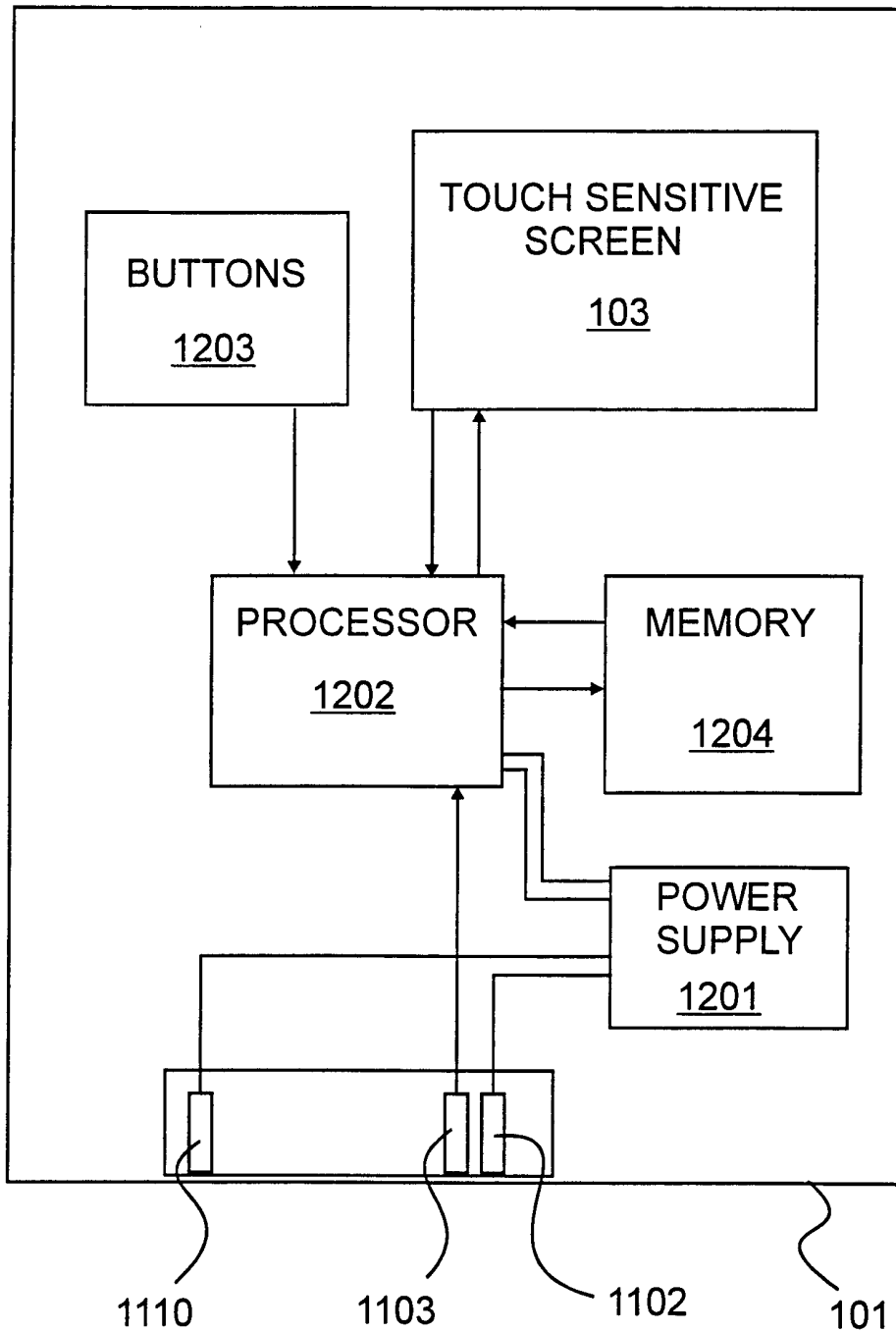

Figure 12

13/15

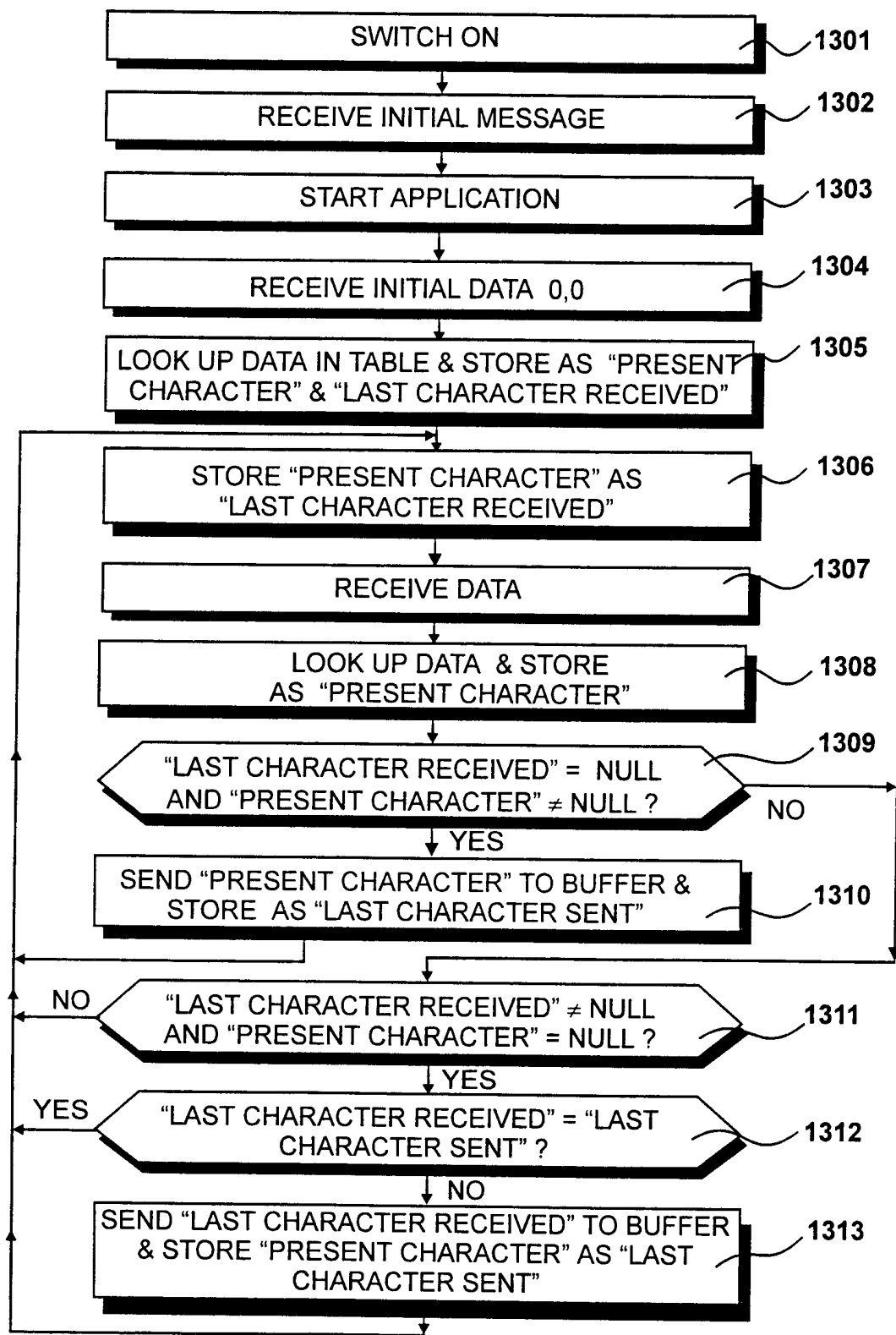

Figure 13

14/15

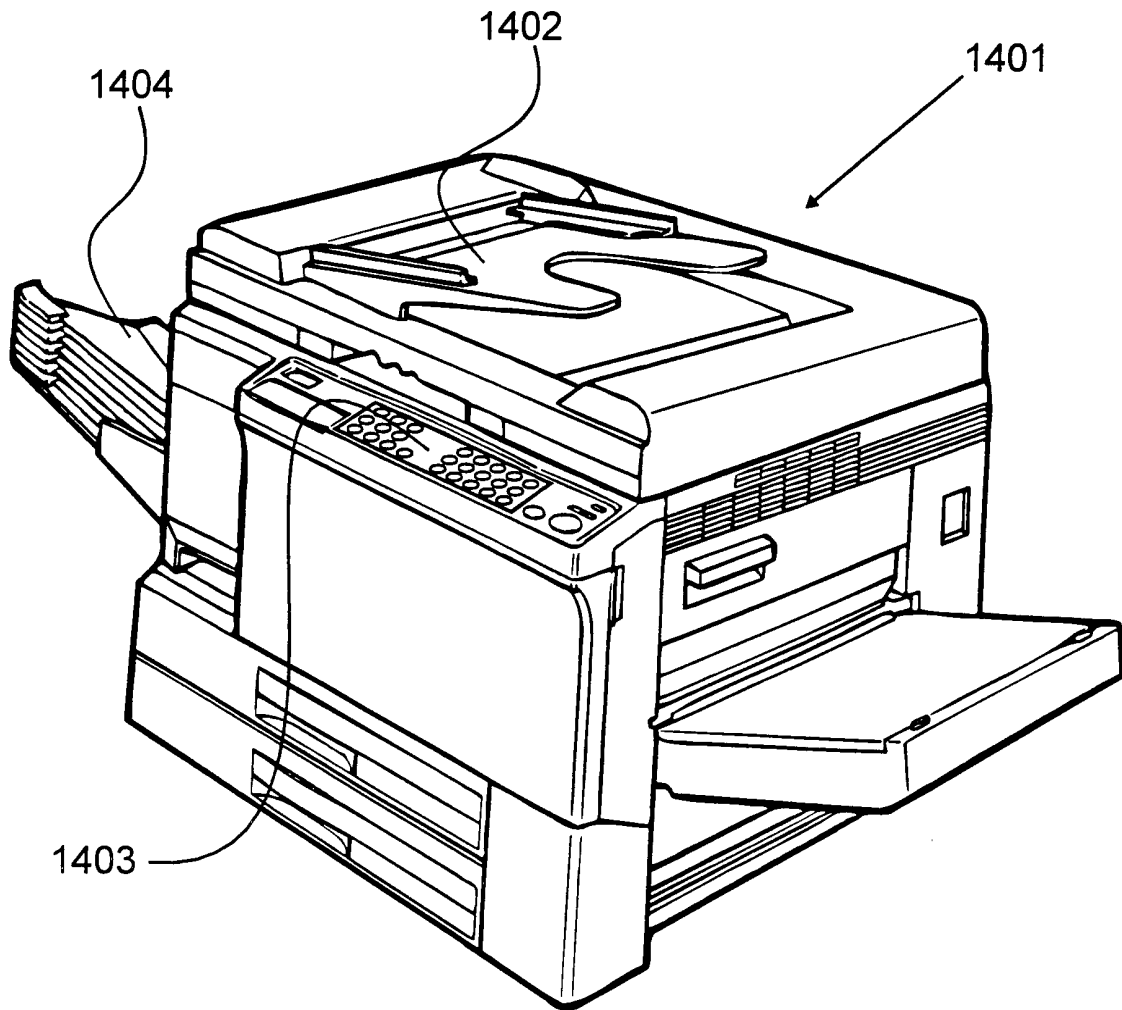

Figure 14

15/15

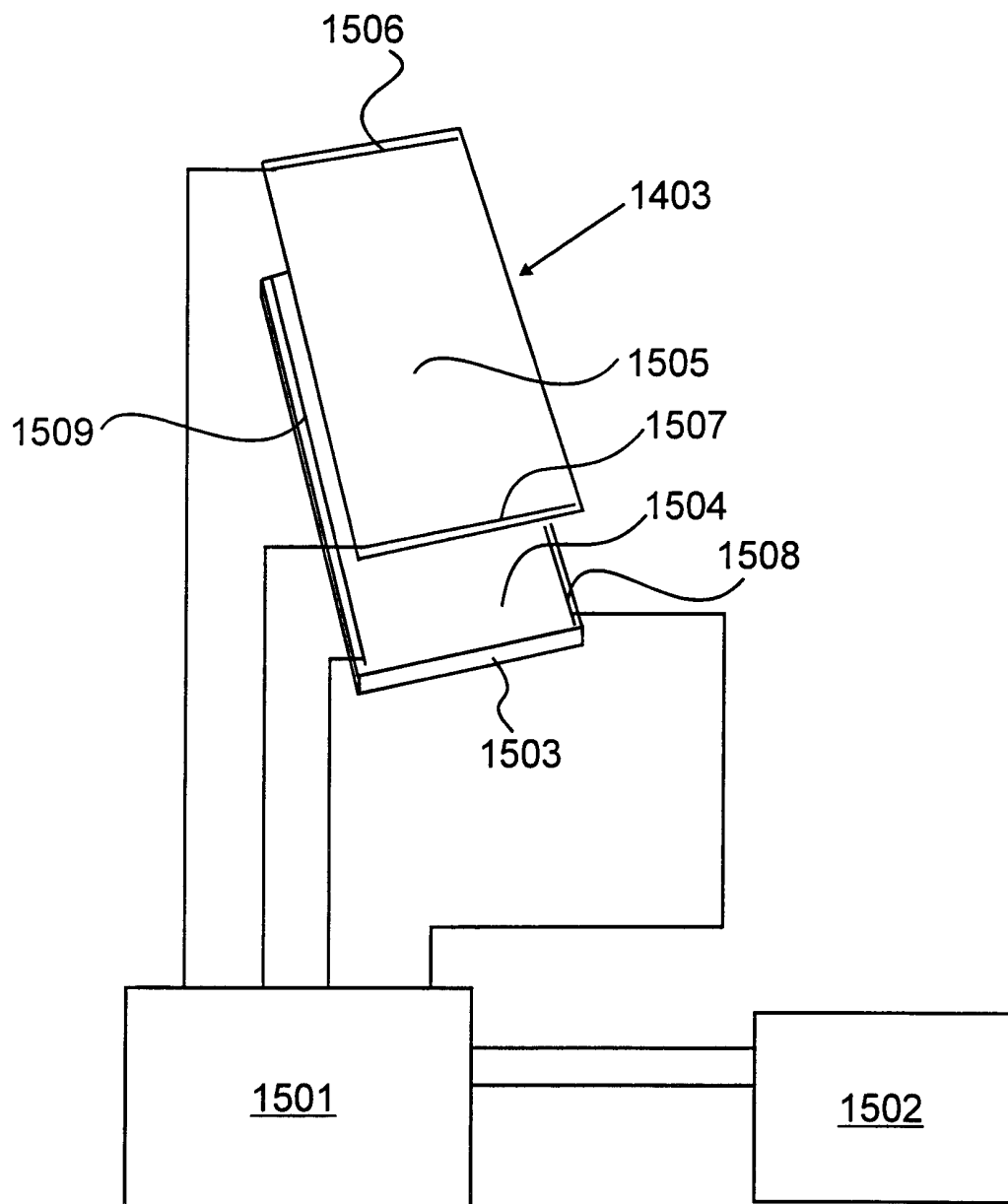

Figure 15