

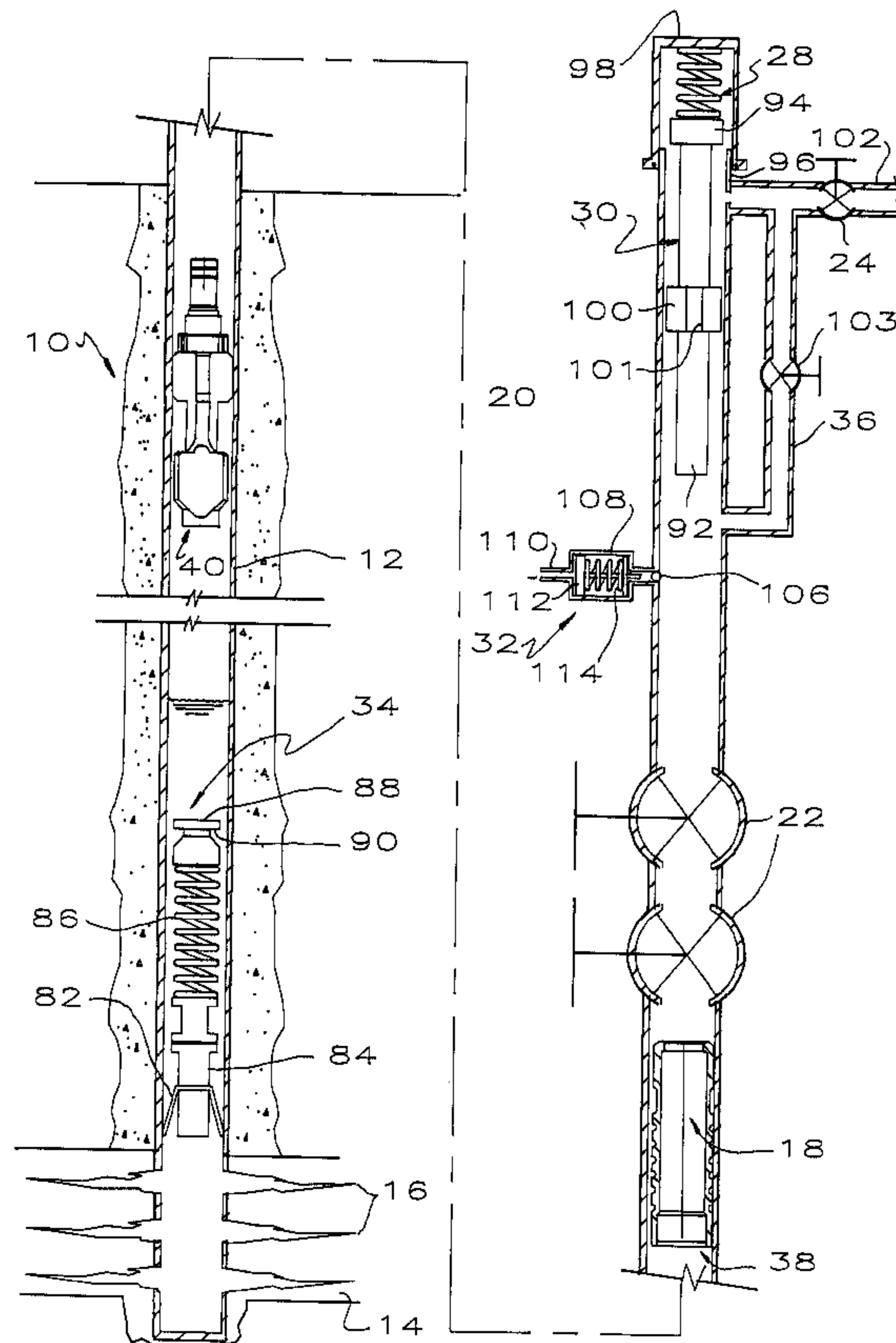

(22) Date de dépôt/Filing Date: 2000/03/21
 (41) Mise à la disp. pub./Open to Public Insp.: 2000/11/14
 (45) Date de délivrance/Issue Date: 2005/11/22
 (30) Priorité/Priority: 1999/05/14 (09/312,737) US

(51) Cl.Int.⁷/Int.Cl.⁷ F04B 47/12, E21B 43/16
 (72) Inventeur/Inventor:
 WELLS, EDWARD A., US
 (73) Propriétaire/Owner:
 MGM WELL SERVICE, INC., US
 (74) Agent: MACRAE & CO.

(54) Titre : POMPE A PISTONS PLONGEURS MULTIPLES
 (54) Title: PLUNGER LIFT WITH MULTIPART PISTON



(57) Abrégé/Abstract:

A plunger lift for a hydrocarbon well includes a multipart piston that is dropped into the well in separate pieces. When the pieces reach the bottom of the well, they fall into an accumulation of the formation liquid in the bottom of the well and unite. Gas from the formation pushes the unit upwardly, pushing liquid above the piston toward the surface.

Abstract of the Invention

5 A plunger lift for a hydrocarbon well includes a multipart piston that is dropped into the well in separate pieces. When the pieces reach the bottom of the well, they fall into an accumulation of the formation liquid in the bottom of the well and unite. Gas from the formation pushes the unit upwardly, pushing liquid above the piston toward the surface.

PLUNGER LIFT WITH MULTIPART PISTON

This invention relates to a plunger lift system for moving liquids upwardly in a petroleum well.

BACKGROUND OF THE INVENTION

5 There are many different techniques for artificially lifting formation liquids from hydrocarbon wells. Reciprocating sucker rod pumps are the most commonly used in the oil field because they are the most cost effective, all things considered, over a wide variety of applications. Other types of artificial lift include electrically driven down hole pumps, hydraulic pumps, rotating rod pumps, 10 free pistons or plunger lifts and several varieties of gas lift. These alternate types of artificial lift are more cost effective than sucker rod pumps in the niches or applications where they have become popular.

15 One of the developments that has evolved over the last thirty years are so-called tubingless completions in which a string of tubing, usually 2 7/8" O.D., is cemented in the well bore and then used as the production string. Tubingless completions are never adopted where pumping a well is initially considered likely because 20 sucker rod pumps have proved to be only slightly less than a disaster when used in a 2 7/8" tubingless completions. Artificial lift in a 2 7/8" tubingless completion is almost universally limited to gas lift or free pistons. Thus, tubingless completions are typically used in shallow to moderately deep wells that are 25 believed, at the time a completion decision is made, to produce all or mostly gas, i.e. no more liquid than can be produced along with the gas.

 Gas wells reach their economic limit for a variety of reasons. A very common reason is the gas production declines to a point 30 where the formation liquids are not readily moved up the production string to the surface. Two phase upward flow in a well is a complicated affair and most engineering equations thought to predict flow are only rough estimates of what is actually occurring. One reason is the changing relation of the liquid and of the 35 gas flowing upwardly in the well. At times of more-or-less constant flow, the liquid acts as an upwardly moving film on the inside of the flow string while the gas flows in a central path on the inside of the liquid film. The gas flows much faster than the liquid film. When the volume of gas flow slows down below some

critical value, or stops, the liquid runs down the inside of the flow string and accumulates in the bottom of the well.

If sufficient liquid accumulates in the bottom of the well, the well is no longer able to flow because the pressure in the reservoir is not able to start flowing against the pressure of the liquid column. The well is said to have loaded up and died. Years ago, gas wells were plugged much quicker than today because it was not economic to artificially lift small quantities of liquid from a gas well. At relatively high gas prices, it is economic to keep old gas wells on production. It has gradually been realized that gas wells have a life cycle that includes an old age segment where a variety of techniques are used to keep liquids flowing upwardly in the well and thereby prevent the well from loading up and dying.

There are many techniques for keeping old gas wells flowing and the appropriate one depends on where the well is in its life cycle. For example, the first technique is to drop soap sticks into the well. The soap sticks and some agitation cause the liquids to foam. The well is then turned to the atmosphere and a great deal of foamed liquid is discharged from the well. Later in its life cycle, when soaping the well has become much less effective, a string of 1" or 1 1/2" tubing is run inside the production string. The idea is that the upward velocity in the small tubing string is much higher which keeps the liquid moving upwardly in the well to the surface. A rule of thumb is that wells producing enough gas to have an upward velocity in excess of 10'/second will stay unloaded. Wells where the upward velocity is less than 5'/second will always load up and die.

At some stage in the life of a gas well, these techniques no longer work and the only approach left to keep the well on production is to artificially lift the liquid with a pump of some description. The logical and time tested technique is to pump the accumulated liquid up the tubing string with a sucker rod pump and allow produced gas to flow up the annulus between the tubing string and the casing string. This is normally not practical in a 2 7/8" tubingless completion unless one tries to use hollow rods and pump up the rods, which normally doesn't work very well or very long. Even then, it is not long before the rods cut a hole in the 2 7/8" string and the well is lost. In addition, sucker rod pumps require a large initial capital outlay and either require electrical service or elaborate equipment to restart the engine.

Free pistons or plunger lifts are another common type of artificial pumping system to raise liquid from a well that produces a substantial quantity of gas. Conventional plunger lift systems comprise a piston that is dropped into the well by stopping upward
5 flow in the well, as by closing the wing valve on the well head. The piston is often called a free piston because it is not attached to a sucker rod string or other mechanism to pull the piston to the surface. When the piston reaches the bottom of the well, it falls into the liquid in the bottom of the well and ultimately into
10 contact with a bumper spring, normally seated in a collar or resting on a collar stop. The wing valve is opened and gas flowing into the well pushes the piston upwardly toward the surface, pushing liquid on top of the piston to the surface. Although plunger lifts are commonly used devices, there is more art than
15 science to their operation.

A major disadvantage of conventional plunger lifts is the well must be shut in so the piston is able to fall to the bottom of the well. Because wells in need of artificial lifting are susceptible to being easily killed, stopping flow in the well has a number of
20 serious effects. Most importantly, the liquid on the inside of the production string falls to the bottom of the well, or is pushed downwardly by the falling piston. This is manifestly the last thing that is desired because it is the reason that wells die. In response to the desire to keep the well flowing when a plunger lift
25 piston is dropped into the well, attempts have been made to provide valved bypasses through the piston which open and close at appropriate times. Such devices are to date quite intricate and these attempts have so far failed to gain wide acceptance.

Disclosures of some interest relative to this invention are
30 U.S. Patents 2,074,912 and 3,090,316.

SUMMARY OF THE INVENTION

In this invention, a multipart piston includes separate pieces that are independently allowed to fall inside the production string toward the productive formation. The cross-sectional area of the
35 separate pieces are such that upward flow of gas is substantially unimpeded and the pieces fall through an upwardly moving stream of gas and liquid. Thus, the piston of this invention is normally dropped into a well while it is flowing. This has a great

advantage because the liquid in a film on the inside of the production string does not fall into the bottom of the well.

When the lower piece nears the bottom of the well, it falls into any liquid near the bottom of the well and contacts a bumper spring which cushions the impact of the device. When the upper piece reaches the lower piece, they unite into a single component that has a cross-sectional area comparable to existing plunger lift pistons, i.e. any gas entering the production string from the formation is under the piston and pushes it upwardly, thereby pushing any liquid upwardly in the well to the surface.

Preferably, one of the pieces is a sleeve having a central passage through which the gas flows as the sleeve falls in the well. The other piece is preferably a mandrel having a pin that fits into the sleeve and substantially blocks flow in the central passage when the pieces are united. The flow passage around the mandrel is basically on the outside as the it falls in the well. The mandrel provides one or more centralizers which hold the pin in the center of the production string to align with the central passage of the sleeve.

When the united components reach the well head at the surface, a decoupler separates the sleeve from the mandrel and allows the mandrel to fall toward the bottom of the well. Conveniently, a catcher holds the sleeve and then releases the sleeve after the mandrel is already on the way to the bottom.

A bypass for produced formation products is conveniently provided in the well head to insure that the sleeve and mandrel separate.

It is an object of this invention to provide an improved plunger lift and method of using the same.

A more specific object of this invention is to provide a multipart piston for a plunger lift in which sections of the piston move separately down into the well, unite near the bottom of the well and then move upwardly as a unit to move liquids toward the surface.

These and other objects of this invention will become more fully apparent as this description proceeds, reference being made to the accompanying drawings and appended claims.

BRIEF DESCRIPTION OF THE DRAWINGS

Figure 1 is a schematic view of a well equipped with a plunger lift system of this invention;

5 Figure 2 is an exploded vertical cross-sectional view of the piston of this invention, showing the sleeve and mandrel;

Figure 3 is a bottom view of the mandrel;

Figure 4 is a top view of the mandrel;

Figure 5 is a broken isometric view of the sleeve;

10 Figure 6 is an isometric view of the mandrel, the top of the mandrel being broken away from the bottom for purposes of illustration;

Figure 7 is a broken isometric view of the bottom of the mandrel, taken at 45° relative to Figure 6;

15 Figure 8 is a horizontal cross-sectional view of Figure 6, taken substantially along line 8--8 thereof, as viewed in the direction indicated by the arrows; and

Figure 9 is a vertical cross-sectional view of the lower end of the mandrel of Figure 6.

DETAILED DESCRIPTION

20 Referring to Figures 1-9, a hydrocarbon well 10 comprises a production string 12 extending into the earth in communication with a subterranean hydrocarbon bearing formation 14. The production string 12 is typically a conventional tubing string made up of joints of tubing that are threaded together. Although the
25 production string 12 may be inside a casing string (not shown), it is illustrated as cemented in the earth. The formation 14 communicates with the inside of the production string 12 through perforations 16. As will be more fully apparent hereinafter, the plunger lift 18 may be used to lift oil, condensate or water from
30 the bottom of the well 10 which may be classified as either an oil well or a gas well.

In a typical application of this invention, the well 10 is a gas well that produces some formation liquid. In an earlier stage of the productive life of the well 10, there is sufficient gas
35 being produced to deliver the formation liquids to the surface. The well 10 is equipped with a conventional well head assembly 20 comprising a pair of master valves 22 and a wing valve 24 delivering produced formation products to a surface facility for separating, measuring and treating the produced products.

The plunger lift 18 of this invention comprises, as major components, a piston 26, an upper bumper 28, a decoupler 30, a catcher assembly 32, a lower bumper 34 and a bypass 36 around the piston 26 when it is its uppermost position in the well head assembly 20.

The piston 26 is of unusual design and is made in at least two pieces which, in a preferred embodiment of the invention, comprises an upper sleeve 38 and a lower mandrel 40. The sleeve 38 comprises a tubular body 42 having a central passage 44, a fishing neck 46 at the upper end thereof and a sealing surface 48 at the lower end thereof.

The exterior of the sleeve 38 provides a seal arrangement 50 to minimize liquid on the outside of the sleeve 38 from bypassing around the exterior of the sleeve 38. The seal arrangement 50 may be of any suitable type, such as wire wound around the sleeve 38 providing a multiplicity of bristles or the like or may comprise a series of simple grooves or indentations 52. The grooves 52 work because they create a turbulent zone between the sleeve 38 and the inside of the production string 12 thereby restricting liquid flow on the outside of the sleeve 38.

The mandrel 40 is of more complex configuration and comprises a body 54 having a robust lower end 56 which takes repeated impacts against the lower bumper, a first centralizer section 58 providing a series of outwardly extending arms 60 and a second centralizer section 62 providing a series of outwardly extending arms 64. The arms 60 are preferably 90° out of phase with the arms 64 so the centralizer sections 58, 62 orient the axis 66 of the mandrel 40 substantially coincident with the axis of the sleeve 38 and of the production string 12. The arms 60, 64 preferably have the same outer dimension as the sleeve 38.

Above the centralizer section 62 is a circular plate 68 having a series of peripheral slots 70 providing a flow bypass between the centralizer arms 64. Above the plate 68 is a pin 72 which extends into the sleeve 38 and provides a frustoconical sealing surface 74, a snap ring groove 76 and a pair of fishing grooves 78. The pin 72 is substantially shorter than the sleeve 38 so, in the upwardly moving or nested position of the piston 26, the pin 72 terminates below the fishing neck 46 of the sleeve 38.

A sealing member 80 slips over the pin 72 and fits onto the sealing surface 74 of the mandrel 40. A washer 81 may be provided

above the sealing member 80 for abutting a snap ring (not shown) which fits in the groove 76 and holds the sealing member 80 in position. When the mandrel 40 nests inside the sleeve 38, the sealing member 80 seals against the sealing surface 48. The
5 sealing member 80 may be of any suitable type and is shown as a Harbison-Fisher nylon seal ring, model 80-190H-10, 1 3/4" HR pump seal.

As will be more fully apparent hereinafter, the mandrel 40 is first dropped into the well 10, followed by the sleeve 38. The
10 mandrel 40 and sleeve 38 accordingly fall separately and independently into the well 10, usually while the well 10 is producing gas and liquid up the production string 12 and through the well head assembly 20. By separately, it is meant that the mandrel 40 and sleeve 38 are not connected. By independently, it is meant that
15 the mandrel 48 and sleeve 38 are capable of moving independently of one another even if they are tethered together in some fashion. When the mandrel 40 and sleeve 38 reach the bottom of the well, they nest together in preparation for moving upwardly.

In one aspect, the sleeve 38 and mandrel 40 each have a flow
20 bypass so they separately fall easily into the well 10 even when there is substantial upward flow in the production string 12. When they reach the bottom of the well, they unite into a single component which substantially closes the flow bypasses, or at least restricts them, so gas entering through the perforations 16 pushes
25 the piston 26 upwardly in the well and thereby pushes liquid, above the piston 26, upwardly toward the well head assembly 20.

Looked at in another perspective, the sleeve 38 and mandrel
40 each have a surface area which is selected so that they separately fall easily in the well but, when they are united into
30 the piston 26, the piston 26 is pushed upwardly in the well thereby pushing any liquid upwardly toward the well head assembly 20. The selection of the surface areas of the sleeve 38 and mandrel 40 is preferably done so that a given pressure differential will move the mandrel 40 before moving the sleeve 38. In other words, the
35 mandrel 40 is easier to move than the sleeve 38. The reason is that is if the mandrel 40 can be constructed so it always pushes from below, there is no tendency for the sleeve 38 to separate from the mandrel 40 during upward movement in the well 10.

This may be illustrated in the following example. A standard
40 size 2 7/8" tubing used as a production string weighs 6.5 #/foot

and has a nominal internal diameter of 2.441" which, of course, is not perfect and which is interrupted in an assembled string by a gap in the coupling of adjacent joints. A conventional one piece plunger lift has an O.D. of about 2.330" and can successfully lift liquid from the bottom of a well. A piston 26 of this invention may have a sleeve 38 with an O.D. of 2.330" and an I.D. of 1.750" so the downwardly facing area of the sleeve 38 is approximately 1.857 square inches. A mandrel 40 for such a sleeve will have a plate 68 of an O.D. of 2.125" and its surface area is somewhat less than 3.547 square inches because of the slots 70. When the sleeve 38 is nested onto the mandrel 40, the O.D. of the sleeve 38 is slightly larger than the plate 68. It will be seen that the area of the mandrel 40 is larger than the area of the sleeve 38 so that any pressure drop applies a greater force to the mandrel 40 than to the sleeve 38. In addition, the ratio of surface area to weight of the mandrel 40 is greater than the ratio of surface area to weight of the sleeve 38.

The upper bumper 28 is of conventional design and comprises a helical spring. Bumpers of this type are well known in the plunger lift art and are commercially available.

The lower bumper 34 sits, or is part of, a conventional collar stop 82 that is supported in the gap provided by couplings between adjacent joints of the production string 12. In a well (not shown) having a tubing string inside a casing string cemented in the earth, the lower bumper 34 typically sits in a seating nipple (not shown) in the tubing string. The lower bumper 34 includes a body 84, a relatively long spring 86 and an anvil 88 providing a conventional fishing neck 90. Because the mandrel 40 falls into the bottom of the well 10 when it is flowing, there is little or no liquid accumulated adjacent the formation 14. Thus, the mandrel 40 tends to strike the lower bumper 34 at higher velocities than conventional plunger pistons. For this reason, a longer, softer bumper spring is desired.

The decoupler 30 acts to separate the piston 26 when it reaches the well head assembly 20. The decoupler 30 comprises a rod 92 sized to pass into the top of the sleeve 38 and is fixed to a piston 94. The piston 94 is larger than a conduit 96 in which the rod 92 reciprocates and is thus prevented from falling into the well 10. The top of the well head assembly 20 is closed with a screw cap 98. A stop 100 on the rod 92 limits upward movement of

the sleeve 38. A series of grooves 101, similar to the grooves 70, allow formation products to pass around the stop 100 and into a flow line 102 connected to the wing valve 24. It will be seen that the piston 26 moves upwardly in the well 10 as one piece. When the sleeve 38 passes onto the end of the rod 92, the rod 92 ultimately contacts the top of the pin 72, stopping upward movement of the mandrel 40 and allowing continued upward movement of the sleeve 38. The end of the rod 92, below the stop 100, is longer than the pin 72 so the mandrel 40 is pushed out of the sleeve 38 thereby releasing the mandrel 40 which falls toward the bottom of the well 10.

The bypass 36 helps prevent the piston 26 from sticking in the well head assembly 20 and may include a valve 103. The bypass 36 opens into the well head assembly 20 below the bottom of the sleeve 38 when it is in its uppermost position in the well head assembly 20. Thus, there will be a tendency of gas flowing through the well head assembly 20 to move through the bypass 36 rather than pinning the sleeve 38 against the stop 100.

A catcher 32 may be provided to latch onto the sleeve 38 and thereby hold it for a while to provide a delay period between successive cycles of the piston 26 and to make certain that the sleeve 38 and mandrel 40 fall separately toward the bottom of the well 10. To these ends, the sleeve 38 is provided with an elongated groove 104 to receive a ball detent 106 forced inwardly into the path of the sleeve 38 by an air cylinder 108 connected to a supply of compressed gas (not shown) through a fitting 110. A piston 112 in the cylinder 108 is biased by a spring 114 to a position releasing the ball detent 106 for movement out of engagement with the slot 104. Pressure is normally applied to the cylinder 108 thereby forcing the ball detent 106 into the path of travel of the sleeve 38. The exterior surfaces of the slot 104 are beveled to cam the ball detent 106 against the force of the compressed gas so the ball detent 106 passes into the slot 104 thereby latching onto the sleeve 38 when it is on the decoupler 30 and preventing it from falling immediately into the well 10. Upon a signal from a controller (not shown), gas pressure is bled from the cylinder 108 allowing the spring 114 to retract the piston 112 and allowing the weight of the sleeve 38 to push the ball detent 106 out of the slot 104 thereby releasing the sleeve 38 for movement downwardly into the well 10.

When it is desired to retrieve the mandrel 40 or the piston 26, the decoupler 30 is replaced with a similar device having a stop 100 but eliminating the rod 92. This causes the piston 26 to impact the bumper 28 without dislodging the mandrel 40. The piston 26 is held in its upward position by the flow of formation products around the piston 26 in conjunction with the catcher 32 which latches onto the sleeve 38.

Operation of the plunger lift 18 of this invention should now be apparent. The mandrel 40 is first dropped into the well 10. It falls rapidly through a rising stream of produced products onto the bumper 34 which substantially cushions the impact and minimizes damage to the mandrel 40. When the sleeve 38 is released by the catcher 32, it falls through the well 10 to the bottom. Because the pin 72 of the mandrel 40 is aligned with the axis 66, the sleeve 38 passes over the pin 72, impacts the top of the plate 68 and seals against the sealing member 80. The combined downwardly surface area of the sleeve 38 and mandrel 40, in their united configuration, is sufficient to allow gaseous products from the formation 14 to push the piston 26, and any liquid above it, upwardly to the well head assembly 20.

As the piston 26 approaches the well head assembly 20, a slug of liquid passes through the wing valve 24 into the flow line 102 toward a surface treatment facility. The sleeve 36 passes over the rod 92 which stops upward movement of the mandrel 40 thereby releasing the mandrel 40 which drops into the well 10 in the start of another cycle. The sleeve 38 is retained by the catcher 32 for a period of time depending on the requirements of the well 10. If the well 10 needs to be cycled as often as possible, the delay provided by the catcher 30 is only long enough to be sure the mandrel 40 will reach the bottom of the well 10 before the sleeve 38. In more normal situations, the sleeve 38 will be retained on the catcher 30 so the piston 26 cycles much less often.

A prototype of this invention has been tested. In a 6000' gas well that loads up and dies with produced liquid, it took seven minutes for the mandrel and sleeve to fall separately to the bottom of the well through the upwardly moving column of gas and water, recombine and return to the surface with 1/4 barrels of water.

Although this invention has been disclosed and described in its preferred forms with a certain degree of particularity, it is understood that the present disclosure of the preferred forms is

only by way of example and that numerous changes in the details of construction and operation and in the combination and arrangement of parts may be resorted to without departing from the spirit and scope of the invention as hereinafter claimed.

CLAIMS:

1. In a plunger lift for lifting liquids from a well producing through a production string communicating with a hydrocarbon formation, comprising

5 a piston having separate sections movable independently downwardly into the well, the sections being united in the well near the hydrocarbon formation and providing an exterior seal for upward movement together in the well for pushing liquid, above the piston, upwardly;

10 a decoupler for separating the sections adjacent an end of upward movement in the well; and

15 a system for holding a first of the sections at a location adjacent the end of upward movement in the well, allowing a second of the sections to fall into the well and, after a delay period, dropping the first section into the well.

2. The plunger lift of claim 1 wherein each of the separate sections provides a downwardly facing cross-sectional area that is insufficient to move the section upwardly in response to gas flow emitting from the formation.

20 3. The plunger lift of claim 1 wherein the piston comprises an upper section, a lower section and no other section.

4. The plunger lift of claim 1 wherein the sections nest together during upward movement in the well.

25 5. The plunger lift of claim 3 wherein a first of the sections comprises a sleeve having the seal thereon and a central passage therethrough and a second of the sections comprises a closure for the central passage.

30 6. The plunger lift of claim 5 further comprising means for sealing between the first and second sections when the sections nest together.

7. The plunger lift of claim 1 wherein the first section comprises an upper section and the second section comprises a lower section below the upper section, the lower section provides at least one centralizer for centering the lower section in the production string.

5

8. The plunger lift of claim 1 wherein the first section comprises an upper section and the second section comprises a lower section below the upper section, the lower section provides at least two axially spaced centralizers for centering the lower section in the production string.

10

9. The plunger lift of claim 1 wherein a first of the sections provides a first flow bypass around the first section allowing the first section to move downwardly in the well against the flow of formation products upwardly in the well and a second section of the sections provides a restrictor for reducing the size of the first flow bypass when the first and second sections are united.

15

10. The plunger lift of claim 1 wherein the sections are separated during downward movement into the well.

20

11. The plunger lift of claim 1 comprising a bumper spring for positioning near the formation for engaging and cushioning impact of one of the sections at a location adjacent an end of downward movement in the well.

25

12. The plunger lift of claim 1 wherein the holding system holds the first section at a location adjacent the decoupler and allows the second section to fall into the well.

30

13. The plunger lift of claim 1 wherein the production string communicates with a hydrocarbon formation through a well head comprising at least one valve controlling flow through the production string, and wherein the decoupler is above the valve

for separating the piston into separate sections thereby allowing the sections to fall separately into the well.

14. The plunger lift of claim 13 wherein the sections unite together adjacent the formation for movement together upwardly in the production string to push liquids upwardly in the well in response to gas flow into the production string from the formation; and further comprising

a bumper spring inside the production string adjacent the formation for engaging the piston and cushioning impact near an end of downward piston movement;

the decoupler separating the sections of the piston in response to upward movement of the piston; and

a catcher includes a device for releasing the first section in response to a signal.

15. The plunger lift of claim 1 wherein

one of the piston sections comprises an upper sleeve providing a central passage and an exterior seal assembly; and

another of the piston sections comprises a lower mandrel movable from a first position out of contact with the upper sleeve to a second position coupled with the sleeve and having at least one centralizer and a pin received in the passage in the second position and providing a fishing shoulder intermediate the passage.

16. The plunger lift of claim 15 further comprising means for sealing between the sleeve and mandrel.

17. The plunger lift of claim 15 further comprising a fishing neck on the upper sleeve.

18. The plunger lift of claim 1 wherein the production string communicates with a hydrocarbon formation through a well head, and further comprising at least one master valve on the production string, a receiver for receiving a plunger lift piston extending upwardly from the master valve, at least one wing valve

in communication with the receiver and leading to a surface installation for receiving hydrocarbons from the formation, and a bypass conduit extending from above the master valve to upstream of the wing valve allowing produced products from the formation to bypass at least part of the receiver and prevent pinning the plunger lift piston in the receiver.

19. A method of lifting liquids from a well producing hydrocarbons from a formation with a plunger lift having a multipart piston, comprising dropping parts of the piston independently in the well comprising dropping a first part of the piston into the well, pausing for a time period and then dropping a second part of the piston into the well, uniting the parts of the piston into a unit near the formation and moving the unit upwardly in the well in response to formation gases passing into the well and thereby pushing liquid upwardly with the piston.

20. The method of claim 19 wherein the dropping step occurs when gas is flowing upwardly in the well.

21. The method of claim 19 wherein the well includes a well head and wherein the dropping step occurs when gas is flowing upwardly in the well and exiting through the well head.

22. The method of claim 19 further comprising repeatedly dropping the first and second parts of the piston into the well and varying the time period between dropping the first part and dropping the second part.

23. The plunger lift of claim 1 wherein the holding system includes a device for adjusting the duration of the time period.

24. The plunger lift of claim 1 wherein the well comprises at least one valve controlling upward flow in the well and wherein the decoupler and the holding system are above the at least one valve.

25. The plunger lift of claim 1 wherein the system for holding the first section at a location adjacent the end of upward movement in the well holds the first section for a time at least sufficient to allow the second section to fall to the bottom of the well before the first section reaches the bottom of the well.

26. The plunger lift of claim 1 wherein the well produces through a well head above ground level and the holding system holds only the first section above ground level.

27. The plunger lift of claim 1 wherein the first section comprises a sleeve having a passage therethrough and the lower section nests in the passage during upward movement in the well and the decoupler comprises a rod for receiving the sleeve near the end of upward movement of the piston and thereby dislodging the second section from the first section and where the system for holding the first section holds the sleeve on the rod.

28. The plunger lift of claim 27 wherein the sleeve comprises a recess on a side thereof and the system for holding the first section comprises a retractable detent for extending into the recess and thereby holding the sleeve.

29. The plunger lift of claim 1 wherein the first section provides a first ratio of surface area to weight and the second section provides a section ratio of surface area to weight, the second ratio being higher than the first ratio.

30. The plunger lift of claim 1 wherein the well is produced through a well head having a valve closing the production string and the decoupler is located adjacent the well head and removable therefrom to provide a location where the first and second sections jointly collect, the well head including a gas flow passage below the location so the first and second sections remain united in response to the flow of gas through the well head whereby the joined first and second sections may be removed from the well head after closing the valve.

31. The method of claim 19 wherein the step of pausing for a time period comprises pausing long enough for the first part of the piston to reach a lower location where liquids occur in the well before the second part reaches the lower location.

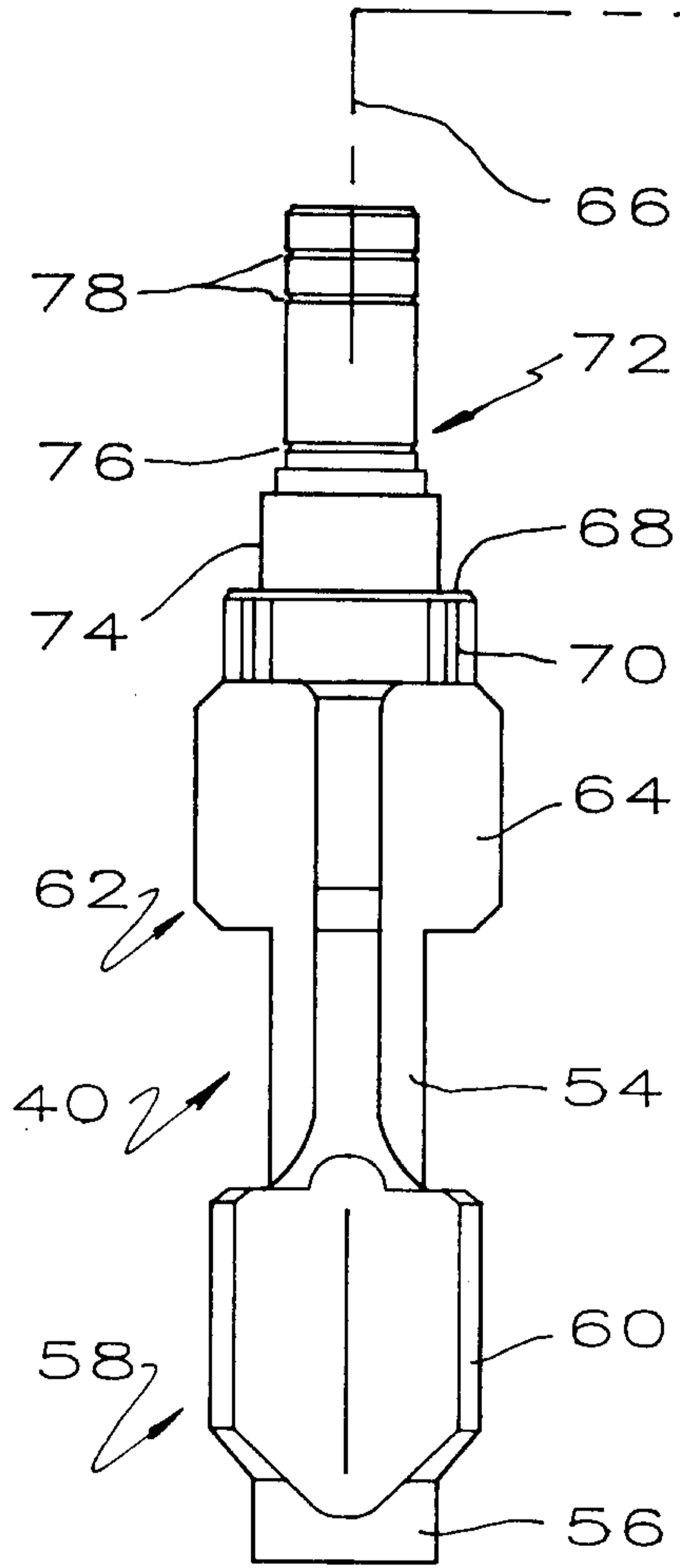

FIG. 2

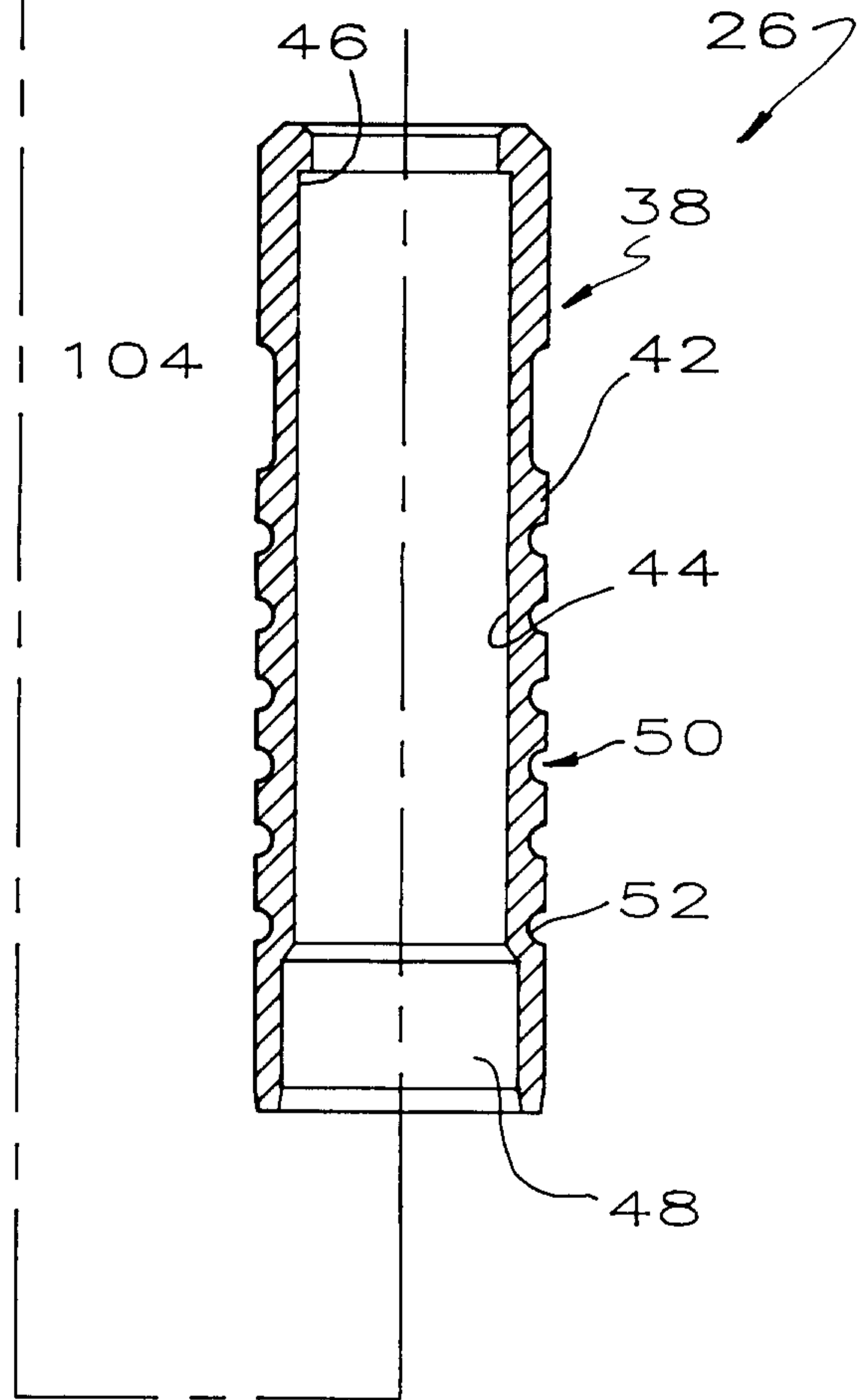

FIG. 3

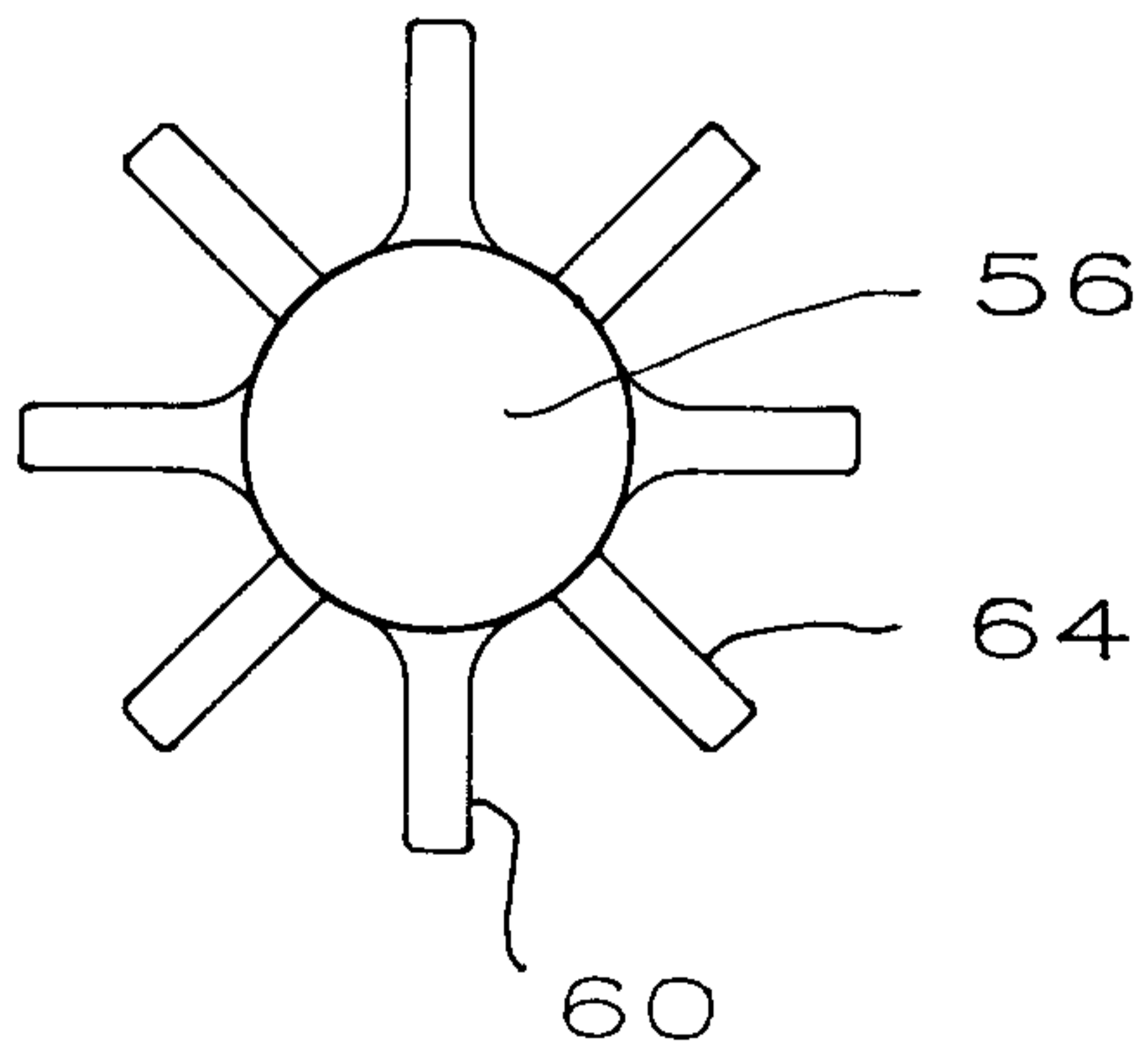
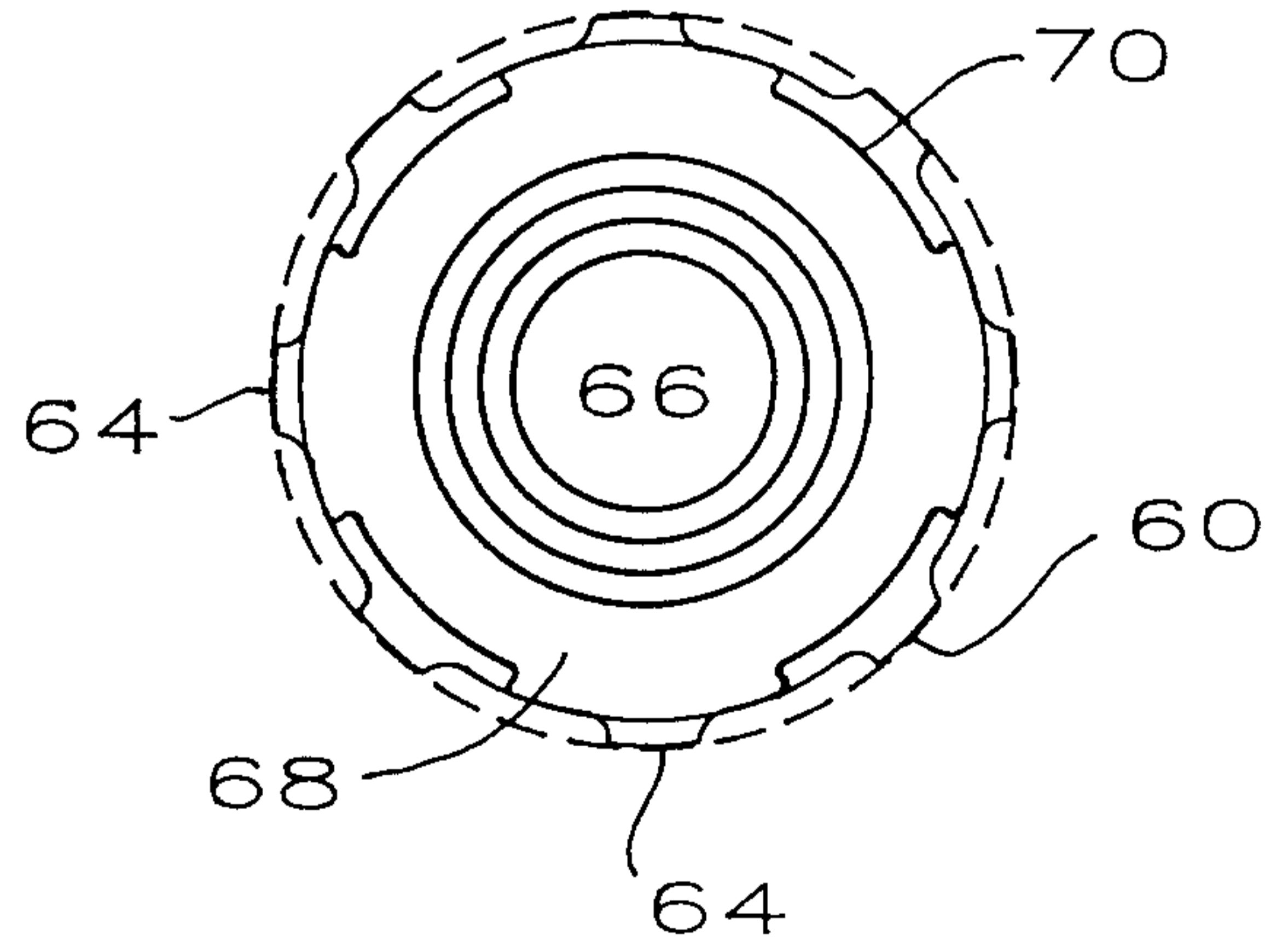

FIG. 4



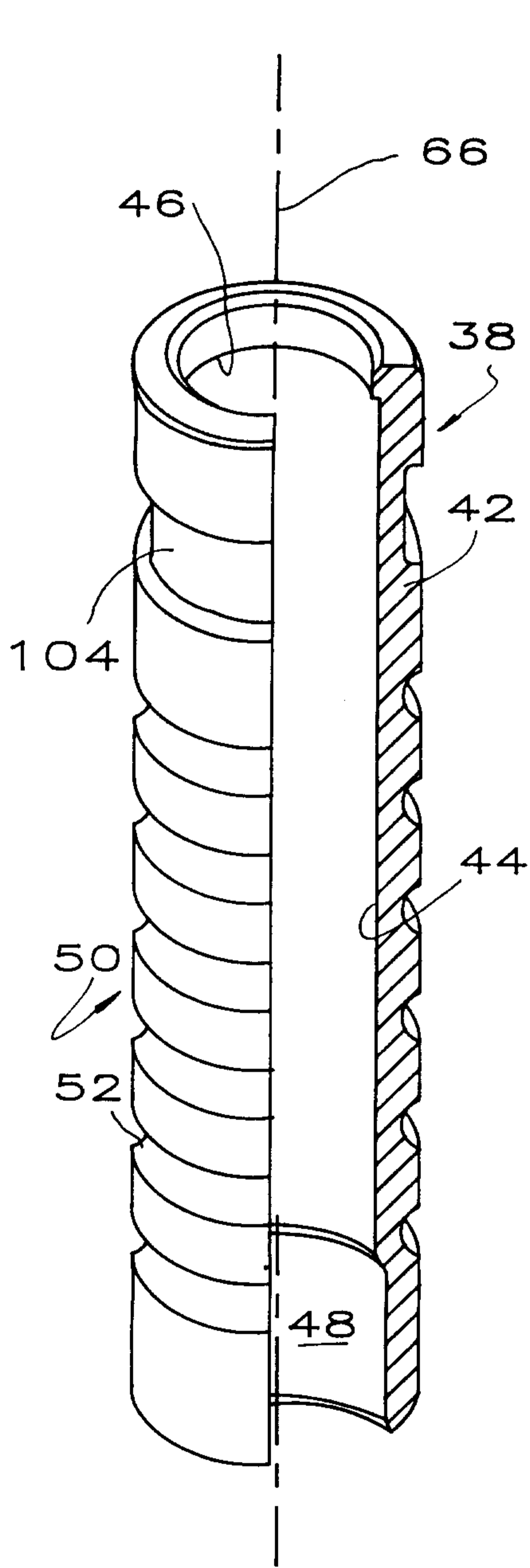

FIG. 5

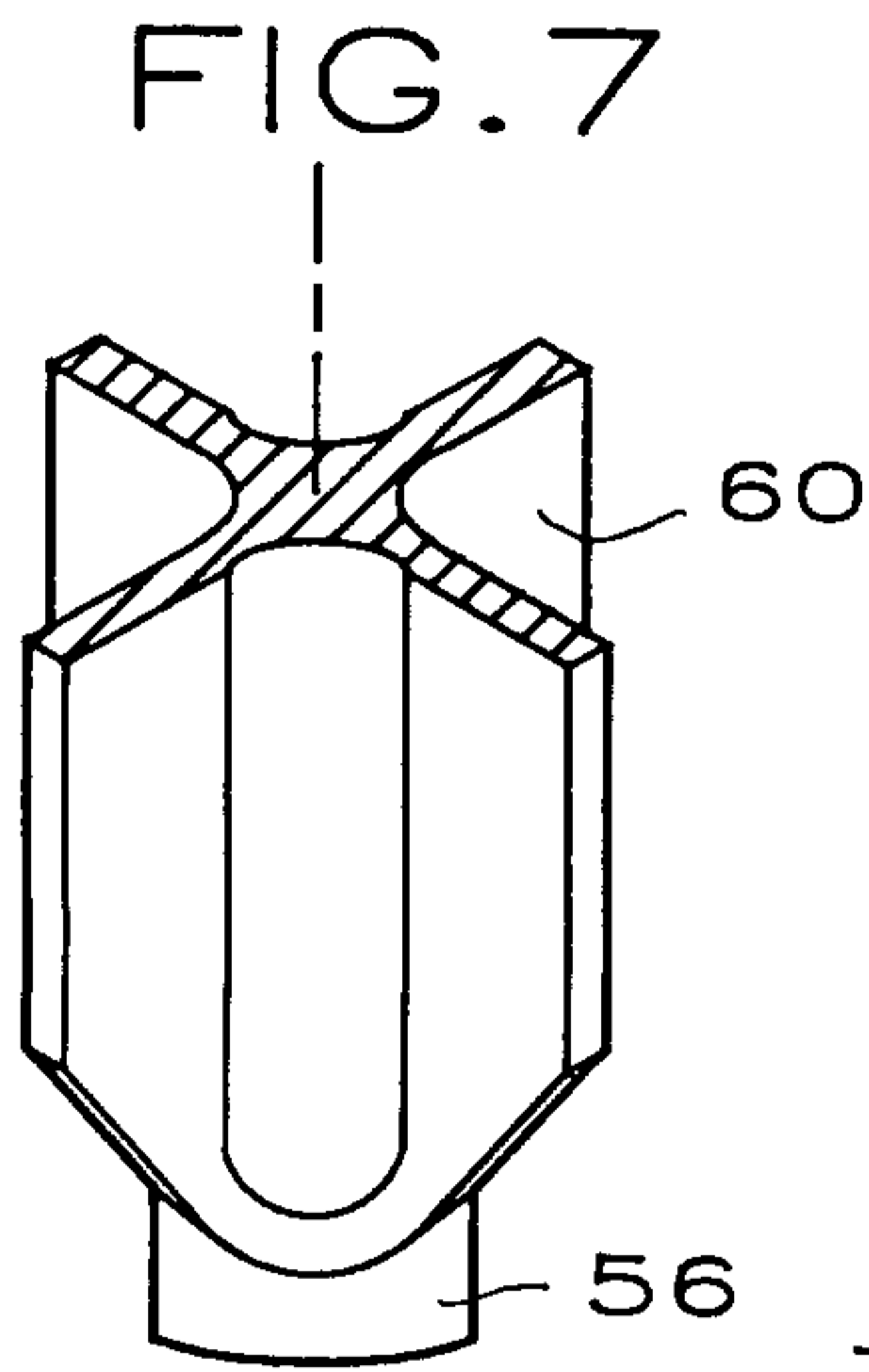

FIG. 7

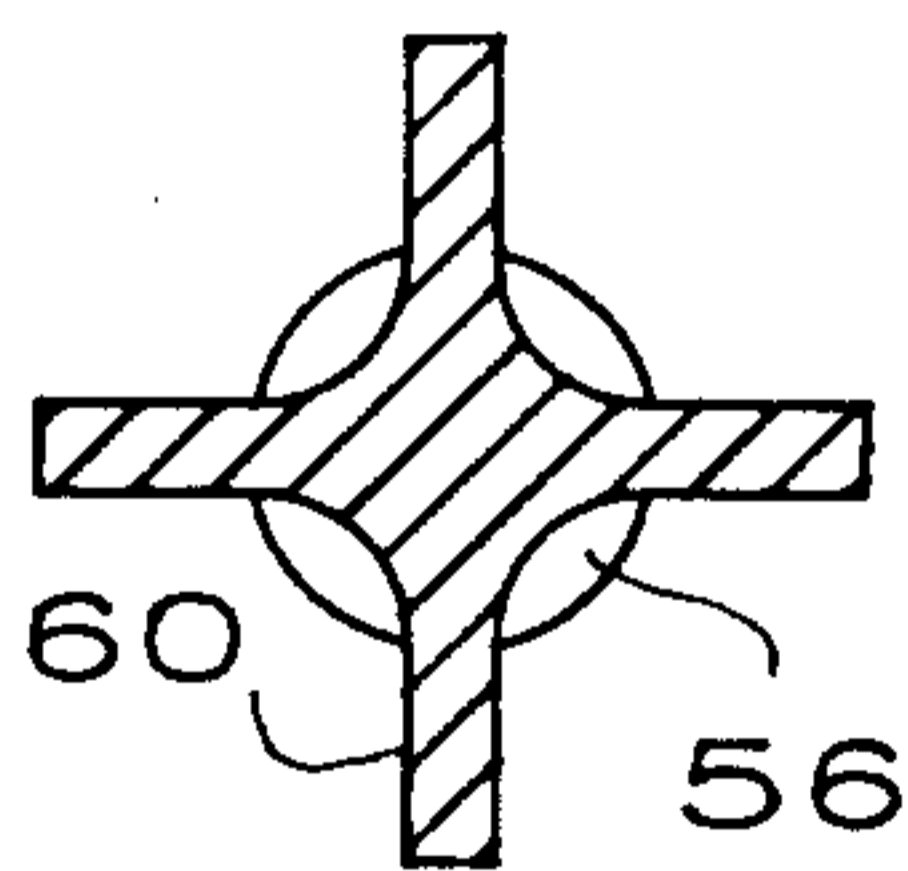

FIG. 8

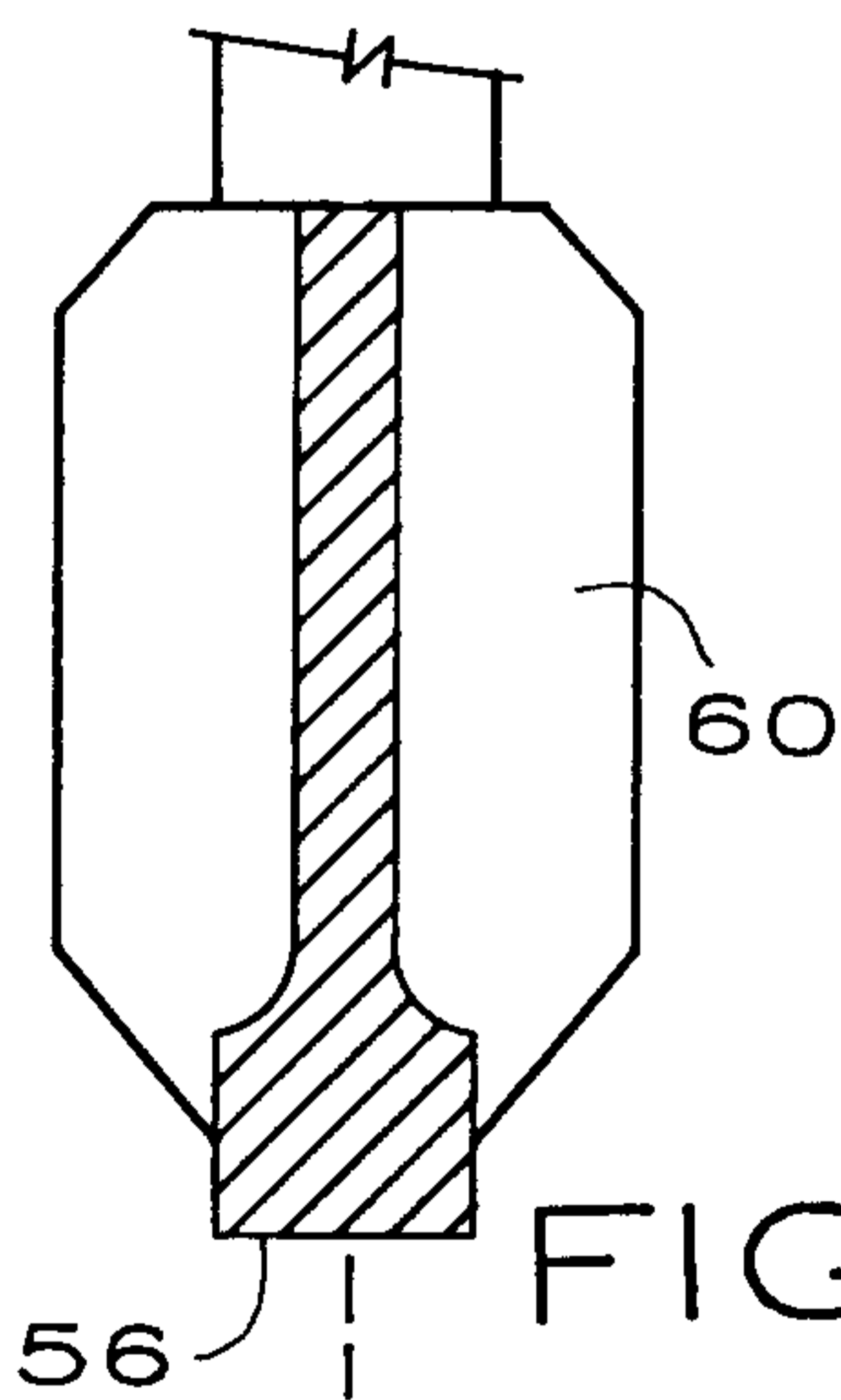

FIG. 9

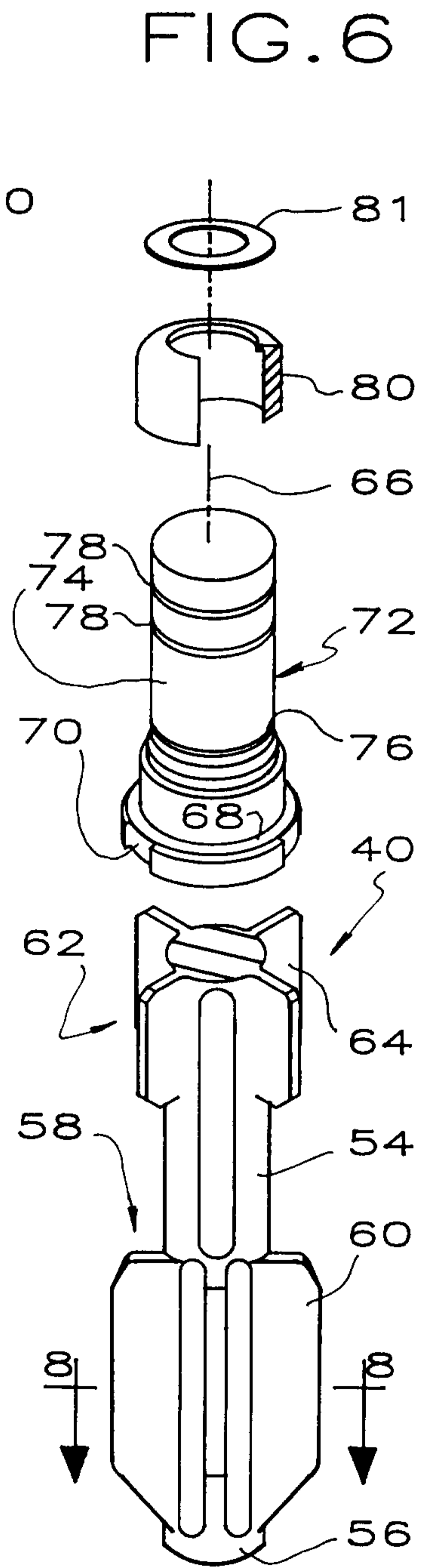

FIG. 6

