

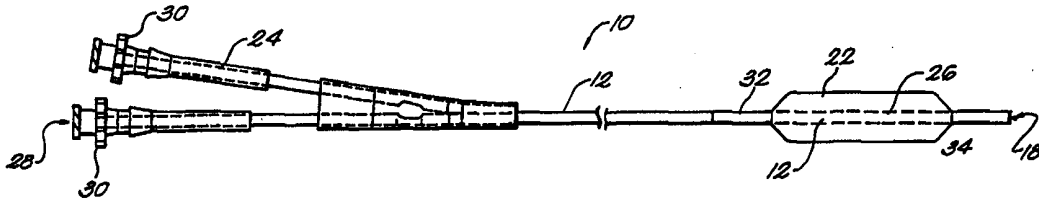

## INTERNATIONAL APPLICATION PUBLISHED UNDER THE PATENT COOPERATION TREATY (PCT)

(51) International Patent Classification <sup>6</sup> : <b>A61B 17/36</b>	<b>A1</b>	(11) International Publication Number: <b>WO 99/45855</b> (43) International Publication Date: 16 September 1999 (16.09.99)
<p>(21) International Application Number: PCT/US99/05040</p> <p>(22) International Filing Date: 8 March 1999 (08.03.99)</p> <p>(30) Priority Data: 09/037,144                      9 March 1998 (09.03.98)                      US</p> <p>(71) Applicant: CARDIOFOCUS, INC. [US/US]; 126B Mid-Tech Drive, West Yarmouth, MA 02673 (US).</p> <p>(72) Inventor: SINOFSKY, Edward, L.; 152 Whittier Drive, Dennis, MA 02638 (US).</p> <p>(74) Agents: ENGELLENER, Thomas, J. et al.; Nutter, McClenen &amp; Fish, LLP, One International Place, Boston, MA 02110-2699 (US).</p>	<p>(81) Designated States: AL, AM, AT, AU, AZ, BA, BB, BG, BR, BY, CA, CH, CN, CU, CZ, DE, DK, EE, ES, FI, GB, GD, GE, GH, GM, HR, HU, ID, IL, IN, IS, JP, KE, KG, KP, KR, KZ, LC, LK, LR, LS, LT, LU, LV, MD, MG, MK, MN, MW, MX, NO, NZ, PL, PT, RO, RU, SD, SE, SG, SI, SK, SL, TJ, TM, TR, TT, UA, UG, UZ, VN, YU, ZW, ARIPO patent (GH, GM, KE, LS, MW, SD, SL, SZ, UG, ZW), Eurasian patent (AM, AZ, BY, KG, KZ, MD, RU, TJ, TM), European patent (AT, BE, CH, CY, DE, DK, ES, FI, FR, GB, GR, IE, IT, LU, MC, NL, PT, SE), OAPI patent (BF, BJ, CF, CG, CI, CM, GA, GN, GW, ML, MR, NE, SN, TD, TG).</p> <p><b>Published</b> <i>With international search report.</i></p>	

(54) Title: THERMAL TREATMENT DEVICE INCLUDING EXPANSION ELEMENT



## (57) Abstract

Medical devices for delivering thermal energy to a targeted tissue site through a body lumen followed by the subsequent dilation of the body lumen. The devices of the present invention include a heat source for supplying heat to a tissue region and a delivery instrument, such as a catheter, for positioning the heat source at a plurality of axial locations within a body lumen. The delivery instrument can further include an open distal end and a lumen through which the heat source can be extended. The heat source is extended beyond the distal end to position the heat source for application of heat. The device further includes an expansion element, such as a dilation balloon, for dilating the lumen following application of heat by the heat source. The medical devices of the present invention are particularly suited for transurethral treatment of benign prostate hyperplasia (BPH).

**FOR THE PURPOSES OF INFORMATION ONLY**

Codes used to identify States party to the PCT on the front pages of pamphlets publishing international applications under the PCT.

AL	Albania	ES	Spain	LS	Lesotho	SI	Slovenia
AM	Armenia	FI	Finland	LT	Lithuania	SK	Slovakia
AT	Austria	FR	France	LU	Luxembourg	SN	Senegal
AU	Australia	GA	Gabon	LV	Latvia	SZ	Swaziland
AZ	Azerbaijan	GB	United Kingdom	MC	Monaco	TD	Chad
BA	Bosnia and Herzegovina	GE	Georgia	MD	Republic of Moldova	TG	Togo
BB	Barbados	GH	Ghana	MG	Madagascar	TJ	Tajikistan
BE	Belgium	GN	Guinea	MK	The former Yugoslav Republic of Macedonia	TM	Turkmenistan
BF	Burkina Faso	GR	Greece	ML	Mali	TR	Turkey
BG	Bulgaria	HU	Hungary	MN	Mongolia	TT	Trinidad and Tobago
BJ	Benin	IE	Ireland	MR	Mauritania	UA	Ukraine
BR	Brazil	IL	Israel	MW	Malawi	UG	Uganda
BY	Belarus	IS	Iceland	MX	Mexico	US	United States of America
CA	Canada	IT	Italy	NE	Niger	UZ	Uzbekistan
CF	Central African Republic	JP	Japan	NL	Netherlands	VN	Viet Nam
CG	Congo	KE	Kenya	NO	Norway	YU	Yugoslavia
CH	Switzerland	KG	Kyrgyzstan	NZ	New Zealand	ZW	Zimbabwe
CI	Côte d'Ivoire	KP	Democratic People's Republic of Korea	PL	Poland		
CM	Cameroon	KR	Republic of Korea	PT	Portugal		
CN	China	KZ	Kazakstan	RO	Romania		
CU	Cuba	LC	Saint Lucia	RU	Russian Federation		
CZ	Czech Republic	LI	Liechtenstein	SD	Sudan		
DE	Germany	LK	Sri Lanka	SE	Sweden		
DK	Denmark	LR	Liberia	SG	Singapore		
EE	Estonia						

## THERMAL TREATMENT DEVICE INCLUDING EXPANSION ELEMENT

### 5 Background of the Invention

The present invention relates generally to thermal treatment and dilation of a body lumen. More particularly, the invention relates to devices for delivering thermal energy to a targeted site through a body lumen and the subsequent dilation of the body lumen.

Prostatic disease is one of the most common diseases in men in the United States.

10 Prostatic disease, as referred to herein, includes benign prostate hyperplasia (BPH), prostatitis, and prostatic cancer. These etiologies effect a majority of men over the age of 50.

In prostatic disease, reduction in the diameter of the lumen, i.e., the prostatic urethra, is induced by compression on the lumen wall due to the proliferation of the  
15 surrounding epithelial and stromal prostate tissue, which is benign in the case of BPH and cancerous in prostatic cancer. This narrowing of the urethra restricts the passage of urine from the bladder. Treatment of BPH typically requires reduction in the prostatic tissue responsible for creating the compressive forces on the urethra which results in the obstruction of urine flow.

20 One conventional treatment for prostate enlargement is transurethral resection of the prostate (TURP) in which prostatic tissue is removed via the urethra. Patients who undergo TURP are typically hospitalized for two to five days afterward and convalesce for another one to six weeks. Complications involving TURP include failure to void or urinary retention, bleeding sufficient to require a transfusion, urinary tract infection, retrograde  
25 ejaculation, and impotence. As a result of the prolonged recovery time, medical costs, and likelihood of serious complications following TURP, alternative methods for treating prostate enlargement have been attempted.

Alternative treatments for BPH include dilation of the urethra and thermal treatment such as, hyperthermia, vaporization, and/or coagulation treatment. Dilation of a urethra  
30 which has become compressed by external forces due to prostatic enlargement is useful primarily as a short term treatment. In the majority of cases, recompression and obstruction of the urethra, accompanied by a recurrence of symptoms, occurs within a relatively short period of time, requiring that the entire process be repeated, which entails

5 considerable expense and inconvenience to the patient. For this reason, dilation treatment alone has lost favor with urologists.

Treatments using thermal energy involve applying hyperthermia, coagulation, or vaporization temperatures to the prostatic tissue by inserting a thermal energy device into the urethra so that the heat generating portion of the device is positioned in the prostatic urethra. Microwave and radio frequency energy devices have been used for thermal treatment of BPH. Thermal treatment of prostatic enlargement has met with only limited effectiveness due to the fact that blood flow to the target cells is not reduced, but typically increases. Because of the increase in blood flow, a heat sink phenomenon occurs which sinks the thermal energy delivered to the target cells, reducing the magnitude and uniforming of heating and cell destruction. This can result in thermal damage occurring to healthy tissue proximate the target tissue and in post-treatment swelling of the heated tissue which can cause temporary restriction of the urethra for several weeks or more after treatment. Consequently, short term urinary retention sufficient to require catheterization of the patient is a frequent complication of thermal treatment, resulting in a longer recovery time and increased patient discomfort, and additional infection risk from the indwelling catheter.

To overcome the problems associated with thermal treatment, simultaneous dilation and thermal treatment has been attempted. In such combined treatments, thermal energy is delivered to the target tissue through an inflated dilation balloon inserted in the prostatic urethra. Application of thermal energy through the dilation balloon has proven less than optimal because the fluid used to inflate the balloon, as well as the balloon itself, absorbs significant amounts of the thermal energy. Thus, increased thermal energy levels are necessary to obtain sufficient therapeutic temperatures at the target tissue. In addition, thermal energy absorption by the dilation fluid necessitates active cooling of the fluid, requiring complex and expensive cooling systems to circulate the fluid through the balloon, as well as requiring high temperature resistant balloon materials. Furthermore, simultaneous dilation and heating can require "cracking" of the walls of the urethra to maintain post-treatment patency because the balloon is dilated before the targeted tissue is sufficiently hot to expand.

5           As the above described and other prior art devices and methods for treatment of prostate enlargement, particularly BPH, have proven less than optimal, it is an object of the present invention to provide improved devices for treatment of BPH that combine the benefits of dilation and thermal treatments while concomitantly reducing post-treatment complications such as urinary retention.

10           Another object of the present invention is to provide a device for treatment of targeted tissue through a body lumen by the application of thermal energy and the subsequent dilation of the body lumen.

          Still another object of the present invention is to provide a combined thermal energy and dilation device for treatment of targeted tissue through a body lumen that permits  
15           increased control over the amount and area of application of thermal energy within the body lumen.

          A further object of the present invention is to provide a combined thermal energy and dilation device for treatment of targeted tissue through a body lumen that is simple and inexpensive to manufacture.

20           Other general and more specific objects of this invention will in part be obvious and will in part be evident from the drawings and the description which follow.

### **Summary of the Invention**

          These and other objects of the present invention are attained by the medical devices  
25           of the present invention for delivering thermal energy to a targeted site through a body lumen followed by the subsequent dilation of the body lumen. The present invention is particularly suited for the transurethral treatment of prostate enlargement due to BPH or prostate cancer. A significant advantage of the present invention is that post-treatment complications, such as urinary retention due to swelling of the treated tissue, can be  
30           minimized by dilating the body lumen, i.e., the urethra, after the application of thermal energy to the target tissue. More particularly, dilation subsequent to heating of the targeted tissue provides at least two advantages: the heated tissue, as well as the body lumen, can be readily molded into the desired configuration; and a cooling fluid can be used within the expansion member to cool the heated tissue during dilation to reduce post-treatment  
35           swelling of the targeted tissue and to complete the molding process. Accordingly, urinary

5 retention subsequent to treatment according to the present invention can be avoided while concomitantly providing long term patency.

According to one aspect of the present invention, devices as disclosed include a heat source for supplying heat to a tissue region and a delivery instrument for positioning the heat source at a plurality of axial locations within a body lumen. The delivery instrument  
10 includes an open distal end and a lumen through which the heat source can be extended. In use, the heat source is extended beyond the distal end of the instrument to position the heat source for application of heat. The device further includes an expansion element for dilating the lumen following application of heat by the heat source.

According to one embodiment of the present invention, the delivery instrument is a catheter  
15 and the expansion element is a balloon. In this embodiment, the balloon is filled with a liquid, such as water or saline, to cool the tissue region after application of heat. The delivery instrument can further include an inflation lumen for inflating the balloon to dilate the body lumen. The balloon preferably has an inflated diameter of less than about 15mm. The inflated diameter of the balloon can be reduced due to the effects of the short term  
20 molding of the body lumen and the long term sloughing of the thermally damaged tissue. In another aspect of the present invention, the expansion element can be coaxially disposed about the heating element (e.g. in a sleeve-like relationship) and can be coupled to the delivery instrument in a manner that permits axial motion relative to the heat source.

In a further aspect of the present invention, the heat source can include an optical  
25 fiber for propagating irradiation from an irradiation source. The heat source can include a light diffusing element. For example, the heat source can include a light transmissive diffuser housing having a first end structured to receive the optical fiber. A light scattering medium can be disposed within the housing such that radiation propagating through the optical fiber enters the scattering medium and a portion of the radiation is scattered outward  
30 through the housing. Preferably, the second end of the heat source includes a reflective surface, whereby radiation propagating through the optical fiber enters the scattering medium and a portion of the radiation is scattered outward through the housing and another portion passes through the scattering medium and is reflected by the reflective surface for retransmission through the scattering medium. The heat source can also include a

5 longitudinally-disposed reflector mean for effecting a radiation exposure pattern having an azimuthal extent of less than 360°.

Alternatively, the heat source can be a microwave emitter for emitting microwave radiation from a microwave radiation source or an RF emitter for emitting RF radiation from a RF radiation source.

10 According to another aspect of the present invention, the outer surface of the expansion member can be coated with an antimicrobial agent, a therapeutic agent and/or an anti-inflammatory agent.

### **Brief Description of the Drawings**

15 These and other features and advantages of the present invention will be more fully understood by reference to the following detailed description in conjunction with the attached drawings in which like reference numerals refer to like elements through the different views. The drawings illustrate principles of the invention and, although generally or occasionally not to scale, may show relative dimensions.

20 FIG. 1 is a side elevational view of a medical apparatus incorporating a heat source and an expansion element according to the teachings of the present invention;

FIG. 2 is end view in cross-section of the delivery instrument of the medical apparatus shown in FIG. 1;

25 FIG. 3A is a side elevational view of the distal end of the medical apparatus of FIG. 1 showing the heat source extending from the distal end of the delivery instrument and the expansion element in the deflated state;

FIG. 3B is a side elevational view of the distal end of the medical apparatus of FIG. 1 showing the heat source retracted within the distal end of the delivery instrument and the expansion element in the inflated state;

30 FIG. 4 is a cross-sectional view of a phototherapeutic apparatus for use with the medical apparatus of FIG. 1 in accordance with the teaching of the present invention;

FIG. 4A is a cross-sectional view of the optical fiber diffusive tip assembly of FIG. 4 taken along the line A-A of FIG. 4;

35 FIG. 5 is a schematic perspective view of the distal end of a stabilizing mechanism in accordance with the teaching of the present invention; and

5           FIG. 5A is a cross-sectional view of the stabilizing mechanism of FIG. 5 along the line B-B.

### **Detailed Description of the Illustrated Embodiments**

10           A medical apparatus 10 useful for the treatment of a targeted tissue region from within a body lumen is illustrated in FIGS. 1, 2, 3A and 3B. The medical apparatus includes a delivery instrument 12 for positioning a heat source 14 at a plurality of axial locations within the body lumen. The delivery instrument 12 includes an open distal end 18 and a central axial lumen 20 through which the heat source 14 is positioned. In use, the heat source 14 is extended beyond the open distal end 18 of the delivery instrument 12 to position the heat source 14 for the application of heat. The medical apparatus 10 further includes an expansion element 22 in the form of a dilation balloon for dilating the body lumen following the application of heat, as is described in detail below.

15           The delivery instrument 12 is in the form of an elongated, hollow tube, such as a catheter. The delivery instrument 12 may be flexible or rigid, although flexible catheters are preferred for most applications. The terms "delivery instrument" and "catheter" as used herein are intended to broadly encompass various instruments which can be passed through body lumens of various kinds, sizes, and shapes. The central axial lumen 20 extends from an open proximal end 28 to the open distal end 18 of the delivery instrument 12. In addition to the central lumen 20, the delivery instrument includes an inflation lumen 24 that is co-axially aligned with the central lumen 20. An opening 26 is formed in the distal end of the inflation lumen 24 to permit fluid to inflate expansion element 22. The illustrated delivery instrument 12 can be constructed from Pebax multi-lumen tubing or from similar suitable materials.

20           Referring to FIG. 1, at the proximal end 28 of the delivery instrument 12, inflation lumen 24 splits from the central lumen 20 to facilitate connection of the inflation lumen 24 to a fluid supply (not shown). Luer locks 30 or other suitable connection means can be provided at the proximal ends of each lumen 20 and 24.

25           The expansion element 22 includes proximal and distal sleeves 32 and 34 to facilitate connection of the expansion element 22 to the delivery instrument 12. The inner diameter of each sleeve 32 and 34 is preferably greater than the outer diameter of the

35



5 delivery instrument 12 to permit the expansion element 22 to fit over the outer surface of the delivery instrument 12. An adhesive or other joining means can be used to secure each sleeve 32 and 34 to the outer surface of the delivery instrument.

As illustrated in FIG. 3A, the deflated diameter of the expansion element 22 is preferably substantially equal to or, at the most slightly greater than, the outer diameter of the delivery instrument 12 to facilitate insertion of the delivery instrument 12 into a body lumen. The expansion element 22 is inflated by fluid introduced to the expansion element through the opening 26 of the inflation lumen 24. A significant advantage of the medical apparatus 10 of the present invention is that the inflated diameter of the expansion element 22 can be less than the inflated diameter of conventional dilation balloons while still providing long term dilation of the body lumen. The inflated diameter of the expansion element 22 can be less than 15 mm and in one preferred embodiment is about 12 mm.

The outer surface of the expansion element can be coated with suitable therapeutic, antimicrobial, and/or anti-inflammatory agents to reduce inflammation of the body lumen during treatment and to minimize the degree of microbial deposition on the outer surface of the expansion member. The coatings can be applied in manner that is known in the art.

The heat source 14 can be an optical fiber for propagating irradiation from an irradiation source, such as a laser, and can also include an optical fiber diffusive tip assembly 110, as illustrated in FIG. 4. The optical fiber diffusive tip assembly 110 is also described in commonly-owned co-pending U.S. Patent Application No. 08/827,631, filed April 10, 1997, and entitled "Phototherapy Methods and Apparatus", which is incorporated herein by reference. The optical fiber diffusive tip assembly 110 includes an optical fiber 112 having a light-transmissive core 114, a cladding 116, and an outer buffer coating 118. The end face of fiber core 114 is inserted into a housing 120 which contains scattering medium 122 with individual scatterer particles 124. Preferably, the medium 122 has a greater refractive index than the housing 120. At the distal end of the housing 120, an end plug 26 is disposed with a mirror reflector 128. An optional second layer 130 can be formed about the housing 120 to permit the use of different polymeric tubing materials and/or allows the introduction of pigmented or etched structures as part of tubing 120.

5 Light propagating through optical fiber core 114 is transmitted into the scatterer medium 122 and scattered in a cylindrical pattern along the length of the assembly 110. Each time the light encounters a scatterer particles, it is deflected and, at some point, the net deflection exceeds the critical angle for internal reflection at the interface between the housing 120 and medium 122. When this happens, the light will exit. Light which does  
10 not exit during this initial pass through the tip is reflected by the mirror 128 and returned through the tip assembly. During the second pass, the remaining radiation (or at least a major portion of this returning radiation) again encounters the scatterers 122 which provide further circumferential diffusion of the light.

The diffusing tip assembly 110 can also a longitudinal reflector strip 162. As  
15 further illustrated in the cross-sectional section of FIG. 4A, the longitudinal reflector 162 can be formed as a partial layer or foil element within a laminate structure, e.g., between layer 120 and layer 130. The longitudinal reflector 162 illustrated in FIGS. 4 and 4A cooperates with the scatterer medium 122 to create an azimuthal exposure pattern of approximately 180°, although it should be clear that other angles of exposure can be simply  
20 achieved by widening (or narrowing) the circumferential extent of the reflector element 162. Various alternative configurations of the reflector can be constructed. For example, the reflector can be disposed on the outside of the housing or can be formed as a coating rather than a foil element. Moreover the longitudinal reflector can be used without reflective end surface 128, if enhanced axial uniformity is not needed.

25 An exemplary optical fiber tip assembly 110 can have a Teflon® FEP tubular housing (O.D. of about 0.5 millimeters and I.D. of about 0.25 millimeters) filled with a silicone and titania scatterer composition and capped with an aluminum-coated reflective mirror. The scatterer medium can be formulated by mixing 70 parts of clear silicone, Mastersil™ Formula 151-Clear (available from Masterbond, Inc. of Hackensack, New Jersey) with one part of  
30 titania filled silicone, Mastersil™ Formula 151-White (also available from Masterbond). It has been found that Teflon® FEP materials (polyperfluoroethylene-propylene copolymers) are preferable for most applications because they do not discolor if they are etched prior to loading with the scatterer medium, although Teflon® PFA materials (polytetrafluoroethylene polymers with perfluoroalkoxy side chains) and Teflon® PTFE (polytetrafluoroethylene) and  
35 other fluoropolymers may also be useful.

5           It has been found that the optical fiber tip assembly 110 described above is preferable  
in most applications, particularly prostate treatment, because more tissue can be heated  
directly in less time, and radiation can be distributed over a larger volume of tissue, thus  
increasing the therapeutic heating effects while reducing the risk of overheating damage to  
surrounding tissue structures. The optical fiber tip assembly 110 thus provides more defined  
10 energy distributions and shorter exposure durations, eliminating the need for a cooling  
balloon or the need to protect healthy tissue. Alternatively, the heat source 14 can be a  
microwave emitter for emitting microwave radiation from a microwave radiation source or an  
RF emitter for emitting RF radiation from a RF radiation source. Suitable microwave and RF  
heating devices are described in U.S. Patent Nos. 5,667,488; 5,620,480; and 5,496,217, all of  
15 which are incorporated herein by reference.

The device of the present invention can be optionally used with a cystoscope in order  
to permit viewing of the delivery instrument 12, as well as the heat source 14 and the  
expansion element 22, within the body lumen during treatment. In particular, the delivery  
instrument 12 can be sized to be positioned within the working lumen of the cystoscope and  
20 thus can be inserted into the body lumen through the cystoscope. The working channel of the  
cystoscope alternatively can be configured to function as the delivery instrument. In the  
alternative, magnetic resonance imaging (MRI) or ultrasonic imaging can be used to view the  
delivery instrument 12 within the body lumen.

The device of the present invention can optionally include a stabilizing mechanism for  
25 centering the heat source 14 within the body lumen to facilitate substantially uniform energy  
distribution to the tissue region exposed to thermal energy. Suitable stabilizing mechanisms  
including proximal and/or distal centering balloons or flexible projecting sheath elements that  
can be suspended to center the device. An exemplary stabilizing mechanism in the form of a  
tubular sheath 212 having a distal end 214 is illustrated in FIGS. 5 and 5A. The tubular  
30 sheath 212 is sized to fit within the delivery instrument 12 and includes a central lumen 216  
for receiving the heat source 14.

The distal end 214 of the sheath 212 is fluted such that axial compression of the  
sheath 212 results in expansion of expansion elements 218 within fluted regions 216. The  
expansion elements 218 can be expanded into contact with the walls of the body lumen to

5 thereby center heat source 14 within the body lumen. Axial compression of the tubular sheath can be accomplished by pulling back the heat source 14 while maintaining the tubular sheath 212 stationary. Alternatively, axial compression can be achieved by holding the heat source 14 stationary and pushing the sheath 212 forward.

10 In operation, the delivery instrument 12 is inserted in the patient's body lumen, i.e. the urethra in the case of prostate treatment, with the expansion element 22 in the deflated state. This makes for easier insertion and minimizes pain to the patient. After full insertion, the heating source 14 is extended from the open distal end 18 of the delivery instrument 12 while maintaining the expansion element in the deflated state, as illustrated in FIG. 3A. The heat source 14 is then positioned within the body lumen proximate the tissue to be treated, i.e. the  
15 prostatic tissue. The heat source 14 heats the tissue to be treated to a therapeutic temperature.

After heating has commenced, and preferably at the conclusion of the thermal treatment, the deflated expansion element 22 is positioned adjacent the treated tissue region. It is preferable for the expansion element 22, in combination with the deliver instrument, to  
20 be slid over the heat source 14 to guide the expansion element into proper position. Accordingly, the heat source 14 operates in a manner analogous to a guide wire. Alternatively, the heat source 14 can be withdrawn into the central lumen 20 of the delivery instrument prior to positioning of the expansion element 22 or exchanged with the delivery instrument.

25 Once properly positioned, a fluid, preferably saline, is pumped through the inflation lumen 24 to inflate the expansion element 22 within the body lumen to thereby dilate the body lumen, as illustrated in FIG. 3B. During the dilation of the body lumen, the collagen fibrils forming the body lumen are stretched to desired shape and size. Inflation of the expansion element 22 after the thermal treatment has commenced has at least two beneficial  
30 effects. First, the pressure of the inflated expansion element 22 against the previously heated fibrils of the body lumen, as well as the treated tissue, molds the fibrils of the body lumen into an open, cylindrical configuration. Due to the previous heating of the collagen fibrils of body lumen adjacent the treated tissue, the fibrils exhibit increased elasticity and thus are extremely receptive to such molding. Second, the inflation fluid within the expansion  
35 element 22 has the beneficial effect of cooling the fibrils of the body lumen and treated tissue

5 thereby reducing post-treatment swelling of both the body lumen and the treated tissue. The cooling process has the further effect of setting the molded fibrils of the body lumen into an open, cylindrical configuration. The thermally treated tissue then becomes like a biological stent, holding the lumen open, and resisting edema forces that can swell the body lumen patency shut.

10 The device of the present invention can be used for various therapeutic purposes. For example, the device can be used to treat prostate disease, including benign prostate hyperplasia (BPH) or cancerous prostate tumors. The application of thermal energy to heat prostate tissue and the subsequent dilation of the urethra can be used in lieu of TURP, balloon dilation, thermal treatment, or combined thermal treatment and balloon dilation in which the  
15 prostate is heat through the inflated balloon. In particular, the device described above is especially useful in both improving the outcome of prostate treatment and minimizing post-treatment complications including urinary retention by molding open and cooling the heated urethra and prostate tissue following the application of thermal energy to the prostate tissue. Thus, the device of the present invention provides long-term patency of the urethra while  
20 concomitantly avoiding post-treatment complications including narrowing of the urethra due to swelling.

Moreover, the device of the present invention permits the heat source 14 to be extended from the delivery instrument 12 and the expansion element 22 for the application of thermal energy to the tissue region. This feature allows the heat source 14 to be place in close  
25 proximity or even direct contact with the tissue region to be treated thus further enhancing the therapeutic effects of the heating. Furthermore, absorption of thermal energy by the inflation fluid and/or the expansion element material is avoided. This reduces the amount of thermal energy required to reach therapeutic temperatures and eliminates the need for complex and expensive cooling systems and materials.

30 Furthermore, the device of the present invention facilitates deployment of the expansion element 22 subsequent to the application of thermal energy by permitting the expansion element to slide over the heat source 14. In this manner, the heat source 14, acts as a guide wire to guide the expansion element 22 to the desired position, i.e., proximate the treated tissue.

5            Additionally, during transurethral treatment of the prostate using the device of the present invention it is unnecessary to provide a separate instrument, such as a catheter, to drain fluid from the urethra, as is commonly required with conventional transurethral instruments. Likewise, it is unnecessary to block the urethra at the bladder entrance to prevent fluid from filling the urethra during the treatment. This is due to the relatively short  
10            duration of the treatment using the device of the present invention. For example, a complete treatment using a 980 nanometer laser diode as the heat source can take less than ten minutes.

              Although the heat source 14 and the expansion element 22 are described above as being inserted into the body lumen by a common delivery instrument, one skilled in the art will recognize that the method of the present invention as described above can be practiced  
15            using a separate delivery instrument for both the heat source and the expansion element. However, use of single common delivery instrument is preferable because of the delay that can be involved in withdrawing the delivery instrument for the heat source and inserting a second delivery instrument for the expansion element. Increased therapeutic effect has been found when the collagen fibrils of the body lumen are stretched prior to any significant  
20            cooling of the fibrils occurring.

              Experimental treatments using the device of the present invention were conducted on dogs experiencing constriction of the urethra due to prostatic enlargement. The device used included an optical fiber in combination with the optical fiber diffusive tip assembly described above and a balloon having an inflated diameter of 12mm. In each case, the  
25            balloon was inflated with saline to 45 psi after thermal treatment of the prostate. The urethral diameter was measured for each dog at multiple points along the length of the urethra. Table 1 lists the results of the treatments:

5

**Table 1**

10

15

20

25

<b>D O G</b>	<b><u>Energy Source</u></b>	<b>Power (time)</b>		<b><u>Dilation Time</u></b>	<b><u>Post-dilation Urethral Dia.</u></b>	
		<b><u>R. Lobe</u></b>	<b><u>L. Lobe</u></b>		<b><u>mean (mm)</u></b>	<b><u>range (mm)</u></b>
1.	980 nm laser diode	35W (180 sec.)	35W (185 sec.)	5 min	6.17 (immediate)	2.8 -6.0
2.	980 nm laser diode	30W (85 sec.)	30W (180 sec.)	5 min	6.26 (immediate)	2.7 -6.4
3.	1.06 μm Nd:YAG	60W (120 sec.)	60W (150 sec.)	10 min	8.47 (immediate)	3.98 -10.3
4.	1.06 μm Nd:YAG	60W (120 sec.)	60W (120 sec.)	5 min	8.07 (immediate)	4.57 -6.55
5.	980 nm laser diode	26-28W (180 sec.)	26-28W (180 sec.)	5 min	10.08 (after 48 hrs.)	3.93 -16.09
6.	1.06 μm Nd:YAG	35W (150 sec.)	35W (150 sec.)	5 min	10.8 (at 48 hrs.)	3.09 -15.54
7.	106 μm Nd:YAG	60W (120 sec.)	60W (120 sec.)	5 min	12.48 (at 7 days)	4.0 -23.58

For comparison, experimental treatments were also conducted using thermal energy alone, i.e. without subsequent dilation of the urethra, Table 2 lists the results of these treatments:

30

5

Table 2

10

15

20

<u>DOG</u>	<u>Power (time)</u>		<u>Post-treatment Urethral Dia.</u>	
	<u>R. Lobe</u>	<u>L. Lobe</u>	<u>mean (mm)</u>	<u>range (mm)</u>
8.	60W (30 sec)	60W (180 sec)	3.67 (immediate)	1.81 - 7.90
9.	60W (45 sec)	60W (300 sec)	2.80 (immediate)	1.40 - 3.68
10.	60W (220 sec)	60W (180 sec)	3.79 (immediate)	3.17 - 4.73
11.	60W (180 sec)	60W (180 sec)	2.75 (immediate)	1.02 - 4.00
12.	60W (120 sec)	60W (120 sec)	7.16 (48 hrs.)	0 - 19.28
13.	60W (120 sec)	60W (120 sec)	1.6 (48 hrs.)	0 - 12.21

25

As is apparent from the data in Tables 1 and 2, the mean post treatment urethral diameter is significantly greater (over 100% greater) in the dogs treated with device of the present invention (Table 1) compared to dogs treated with thermal energy alone (Table 2). Significantly, none of these dogs experienced post-treatment constriction of the urethra.



5 Compare dogs 12 and 13, treated with thermal energy alone, which experienced complete constriction of the urethra, causing urinary retention, 48 hours after treatment.

Although the device and method of the present invention as described above relates to the treatment of prostate disease, the device and methods of the present invention are also useful for the treatments of other conditions in which it is desirable to hyperthermally treated  
10 diseased tissue and subsequently dilate a body lumen of a patient which has become compressed or obstructed by the diseased target tissue and/or surrounding tissue. Such other conditions include, but are not limited to, tumors of the esophagus and gastro-intestinal tract and atherosclerosis. It will be evident that appropriate adjustment in the dimensions of the device may be required for use in the treatment of other conditions to adapt to the prevailing  
15 anatomical dimensions.

It will thus be seen that the invention efficiently attains the objects set forth above, among those made apparent from the preceding description. Since certain changes may be made in the above constructions without departing from the scope of the invention, it is intended that all matter contained in the above description or shown in the accompanying  
20 drawings be interpreted as illustrative and not in a limiting sense.

It is also to be understood that the following claims are to cover all generic and specific features of the invention described herein, and all statements of the scope of the invention which, as a matter of language, might be said to fall therebetween.

Having described the invention, what is claimed as new and desired to be secured by  
25 Letters Patent is:

- 5 1. A medical apparatus comprising:  
a heat source for supplying heat to a tissue region,  
a delivery instrument for positioning the heat source at a plurality of axial  
locations within a body lumen, the delivery instrument having an open distal end and a lumen  
through which the heat source can be extended beyond the distal end to position the heat  
10 source for application of heat, and  
expansion element for dilating the lumen following application of heat by the  
heat source.
- 15 2. The medical apparatus according to claim 1, wherein the delivery instrument is  
a catheter.
3. The medical apparatus according to claim 1, wherein the expansion element is  
a balloon.
- 20 4. The medical apparatus according to claim 3, wherein the balloon is filled with  
a liquid to cool the tissue region after application of heat.
5. The medical apparatus according to claim 4, wherein the liquid is water or  
saline.
- 25 6. The medical apparatus according to claim 3, wherein the delivery instrument  
further includes an inflation lumen for inflating the balloon to dilate the body lumen.
7. The medical apparatus according to claim 3, wherein the balloon has an  
30 inflated diameter of less than about 15mm.
8. The medical apparatus according to claim 1, wherein the expansion element is  
coaxially disposed about the heating element.

- 5 9. The medical apparatus according to claim 8, wherein the expansion element is coupled to the delivery instrument.
10. The medical apparatus according to claim 9, wherein the expansion element is coupled to the delivery instrument for axial motion relative to the heat source.
- 10 11. The medical apparatus according to claim 1, wherein the heat source is an optical fiber for propagating irradiation from an irradiation source.
- 15 12. The medical apparatus according to claim 11, wherein the optical fiber includes a light diffusing portion.
13. The medical apparatus according to claim 1, wherein the heat source is a microwave emitter for emitting microwave radiation from a microwave radiation source.
- 20 14. The medical apparatus according to claim 1, wherein the heat source is an RF emitter for emitting RF radiation from a RF radiation source.
15. The medical apparatus according to claim 1, wherein the heat source comprises
- 25 an optical fiber for propagating radiation from an irradiation source,  
a light transmissive diffuser housing having a first end structured to receive the optical fiber, and
- 30 a light scattering medium disposed within the housing, such that radiation propagating through the optical fiber enters the scattering medium and a portion of the radiation is scattered outward through the housing.
16. The medical apparatus according to claim 15, wherein the heat source further comprises a second end having a reflective surface, whereby radiation propagating through the optical fiber enters the scattering medium and a portion of the radiation is scattered

5 outward through the housing and another portion passes through the scattering medium and is reflected by the reflective surface for retransmission through the scattering medium.

17. The medical apparatus according to claim 16, wherein the heat source further comprises a longitudinally-disposed reflector mean for effecting a radiation exposure pattern  
10 having an azimuthal extent of less than 360°.

18. The medical apparatus according to claim 1, wherein the outer surface of the expansion member is coated with an antimicrobial agent.

15 19. The medical apparatus according to claim 1, wherein the outer surface of the expansion member is coated with a therapeutic agent.

20. The medical apparatus according to claim 1, wherein the outer surface of the expansion member is coated with an anti-inflammatory agent.  
20

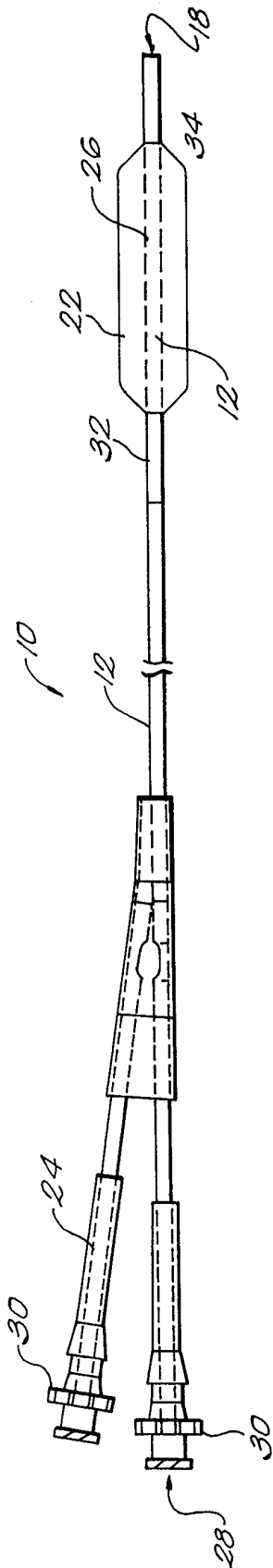

FIG. 1

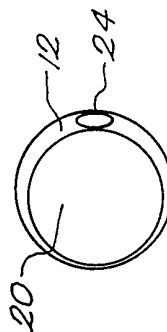
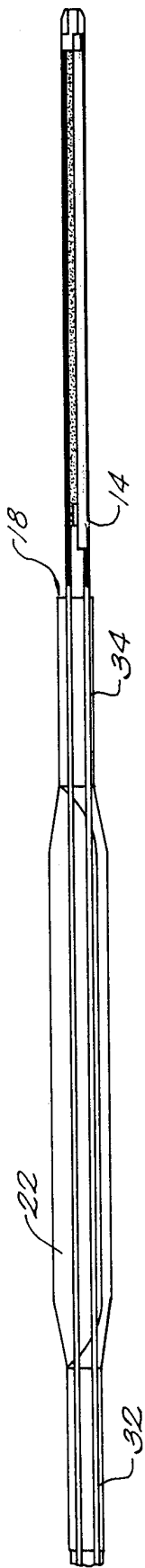
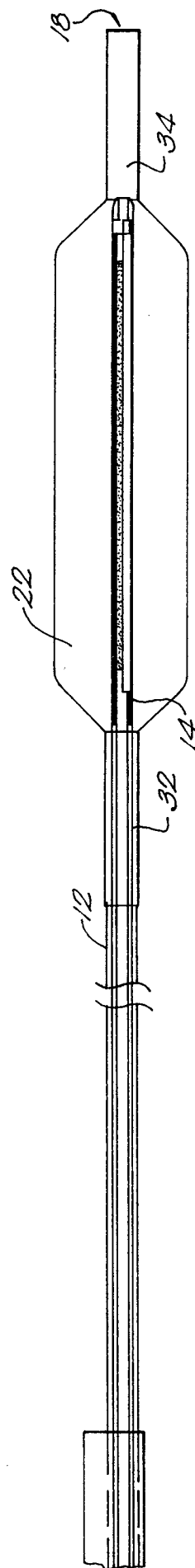

FIG. 2

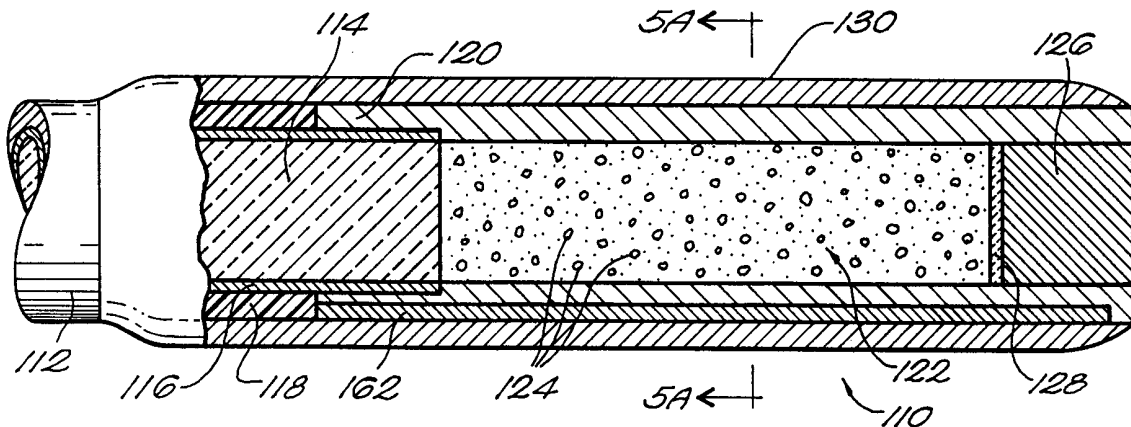

**FIG. 3A**

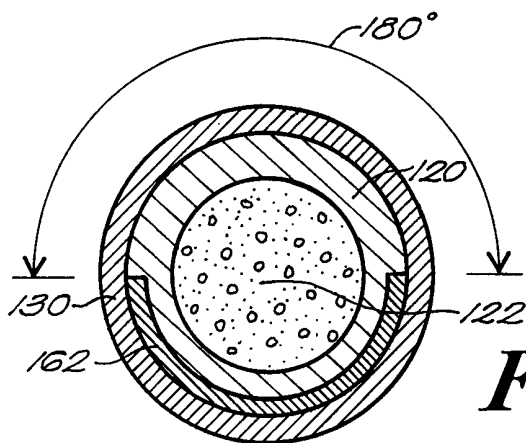

**FIG. 3B**

3 / 3



**FIG. 4**



**FIG. 4A**

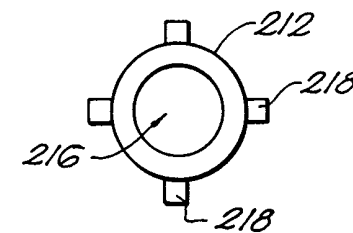
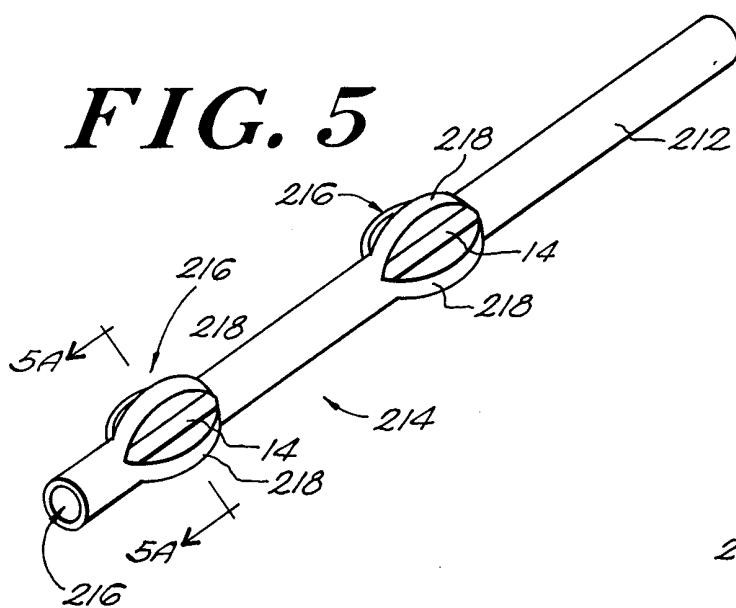

**FIG. 5A**

# INTERNATIONAL SEARCH REPORT

International Application No

PCT/US 99/05040

**A. CLASSIFICATION OF SUBJECT MATTER**

IPC 6 A61B17/36

According to International Patent Classification (IPC) or to both national classification and IPC

**B. FIELDS SEARCHED**

Minimum documentation searched (classification system followed by classification symbols)

IPC 6 A61B

Documentation searched other than minimum documentation to the extent that such documents are included in the fields searched

Electronic data base consulted during the international search (name of data base and, where practical, search terms used)

**C. DOCUMENTS CONSIDERED TO BE RELEVANT**

Category °	Citation of document, with indication, where appropriate, of the relevant passages	Relevant to claim No.
X	US 5 178 620 A (EGGERS PHILIP E ET AL) 12 January 1993	1-10, 14
Y	see column 6, line 3 - line 8 see column 6, line 55 - line 61 see column 7, line 19 - line 26 see column 7, line 65 - column 8, line 46 ---	13, 18-20
Y	US 5 509 929 A (PERRIN PAUL ET AL) 23 April 1996 see column 3, line 1 - line 7 see column 6, line 16 - line 39 ---	13, 18-20
X	US 5 188 634 A (LOEB MARVIN ET AL) 23 February 1993	1-12, 17
Y	see column 3, line 5 - line 12 see column 4, line 30 - line 46 see column 6, line 28 - line 52 see column 7, line 30 - line 37 ---	15
	-/--	

Further documents are listed in the continuation of box C.

Patent family members are listed in annex.

° Special categories of cited documents :

- "A" document defining the general state of the art which is not considered to be of particular relevance
- "E" earlier document but published on or after the international filing date
- "L" document which may throw doubts on priority claim(s) or which is cited to establish the publication date of another citation or other special reason (as specified)
- "O" document referring to an oral disclosure, use, exhibition or other means
- "P" document published prior to the international filing date but later than the priority date claimed

- "T" later document published after the international filing date or priority date and not in conflict with the application but cited to understand the principle or theory underlying the invention
- "X" document of particular relevance; the claimed invention cannot be considered novel or cannot be considered to involve an inventive step when the document is taken alone
- "Y" document of particular relevance; the claimed invention cannot be considered to involve an inventive step when the document is combined with one or more other such documents, such combination being obvious to a person skilled in the art.
- "&" document member of the same patent family

Date of the actual completion of the international search

15 June 1999

Date of mailing of the international search report

23/06/1999

Name and mailing address of the ISA

European Patent Office, P.B. 5818 Patentlaan 2  
NL - 2280 HV Rijswijk  
Tel. (+31-70) 340-2040, Tx. 31 651 epo nl,  
Fax: (+31-70) 340-3016

Authorized officer

Gérard, B



# INTERNATIONAL SEARCH REPORT

International Application No

PCT/US 99/05040

**C.(Continuation) DOCUMENTS CONSIDERED TO BE RELEVANT**

Category	Citation of document, with indication, where appropriate, of the relevant passages	Relevant to claim No.
Y	US 5 454 794 A (ANDERSON STEVEN C ET AL) 3 October 1995 see column 3, line 15 - line 30 ---	15
A	US 5 409 483 A (CAMPBELL PETER ET AL) 25 April 1995 see column 11, line 22 - line 38 see column 12, line 34 - column 13, line 25 ---	1,4,17
A	US 5 609 591 A (DAIKUZONO NORIO) 11 March 1997 see column 4, line 29 - line 42 see column 6, line 27 - line 51 -----	15,16

# INTERNATIONAL SEARCH REPORT

Information on patent family members

International Application No

PCT/US 99/05040

Patent document cited in search report		Publication date	Patent family member(s)	Publication date
US 5178620	A	12-01-1993	US 4998933 A	12-03-1991
<hr style="border-top: 1px dashed black;"/>				
US 5509929	A	23-04-1996	CA 2031740 A,C	08-06-1992
			FR 2639238 A	25-05-1990
			FR 2659519 A	13-09-1991
			FR 2693116 A	07-01-1994
			US 5234004 A	10-08-1993
			WO 9401177 A	20-01-1994
			AT 129910 T	15-11-1995
			DE 68924760 D	14-12-1995
			DE 68924760 T	11-04-1996
			EP 0370890 A	30-05-1990
			EP 0459535 A	04-12-1991
			ES 2022063 T	01-10-1990
			GR 3018153 T	29-02-1996
			JP 2180279 A	13-07-1990
			US 5480417 A	02-01-1992
			DE 8916291 U	25-09-1997
			GR 91300117 T	20-03-1992
			AT 112973 T	15-11-1994
			CA 2082497 A	13-09-1991
			DE 69104714 D	24-11-1994
			DE 69104714 T	01-06-1995
			WO 9113650 A	19-09-1991
			EP 0519958 A	30-12-1992
<hr style="border-top: 1px dashed black;"/>				
US 5188634	A	23-02-1993	NONE	
<hr style="border-top: 1px dashed black;"/>				
US 5454794	A	03-10-1995	NONE	
<hr style="border-top: 1px dashed black;"/>				
US 5409483	A	25-04-1995	NONE	
<hr style="border-top: 1px dashed black;"/>				
US 5609591	A	11-03-1997	US 5415654 A	16-05-1995
			AT 169477 T	15-08-1998
			DE 69412406 D	17-09-1998
			DE 69412406 T	29-04-1999
			EP 0646360 A	05-04-1995
			EP 0845244 A	03-06-1998
			ES 2122116 T	16-12-1998
<hr style="border-top: 1px dashed black;"/>				