



US 20140200096A1

(19) **United States**

(12) **Patent Application Publication**  
**Cheek**

(10) **Pub. No.: US 2014/0200096 A1**

(43) **Pub. Date: Jul. 17, 2014**

(54) **TRANSITION PILOT**

(71) Applicant: **David Alan Cheek**, Washington, DC  
(US)

(72) Inventor: **David Alan Cheek**, Washington, DC  
(US)

(21) Appl. No.: **13/744,239**

(22) Filed: **Jan. 17, 2013**

**Publication Classification**

(51) **Int. Cl.**  
**A63B 69/36** (2006.01)

(52) **U.S. Cl.**

CPC ..... **A63B 69/3667** (2013.01)

USPC ..... **473/277; 473/266**

(57) **ABSTRACT**

A protruding device is used to encumber a user's ability to maneuver his/her hips beyond its position while executing/simulating a golf swing. The protruding device comprises a telescopic beam, having a ball affixed to one end and a pointed, coaxial, coned tip affixed to the other. Additionally, options exist for attachment to a weighted base, specifically designed for indoor application or operability on non-penetrable surfaces.

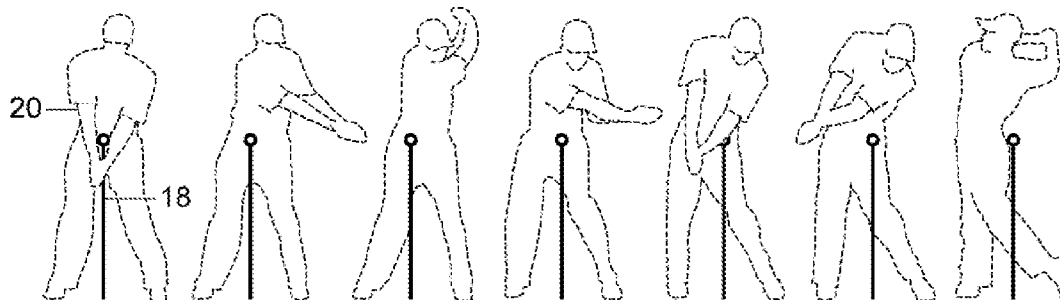

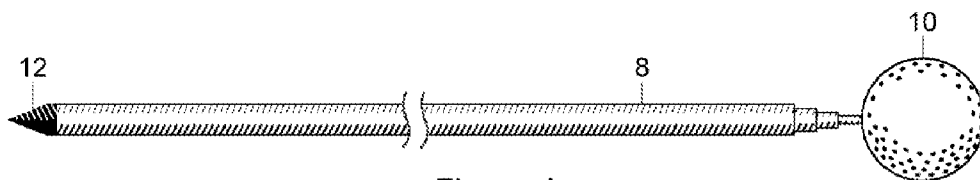

Figure 1

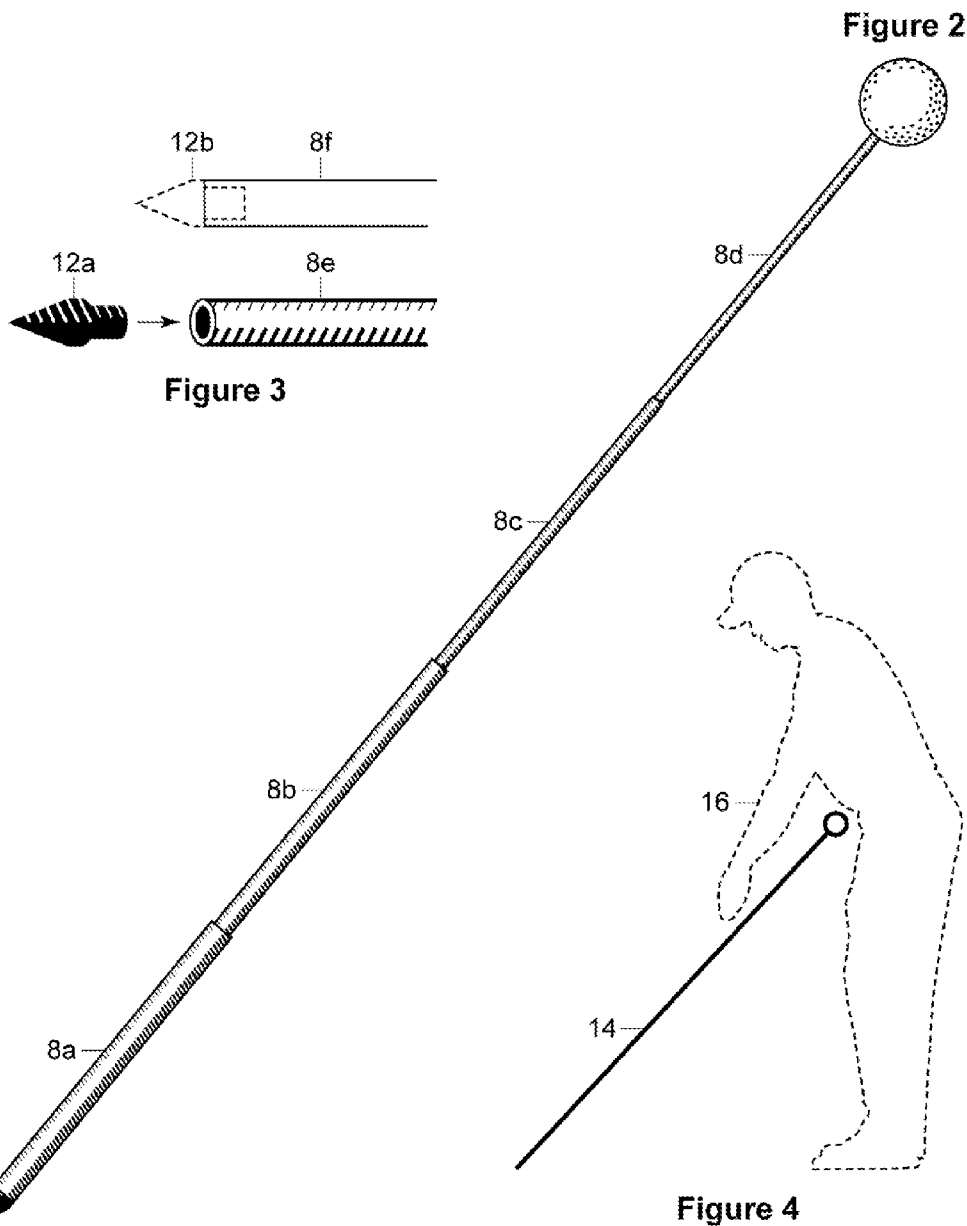

Figure 2

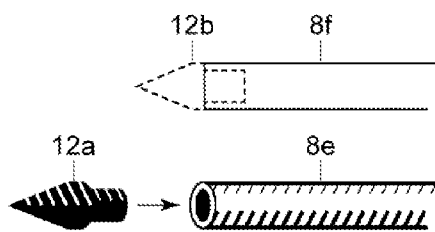

Figure 3

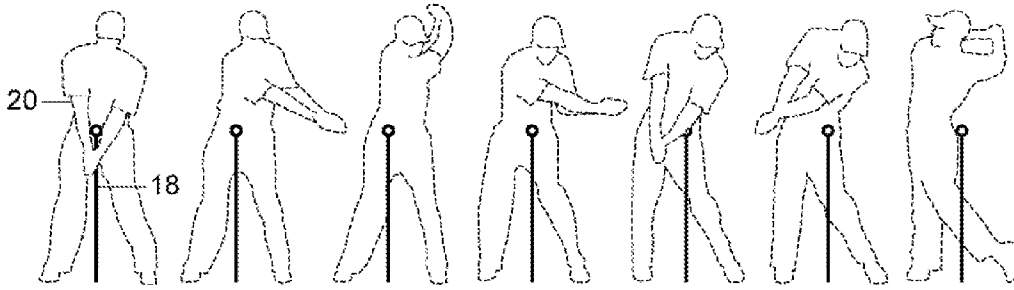

Figure 5

Figure 6

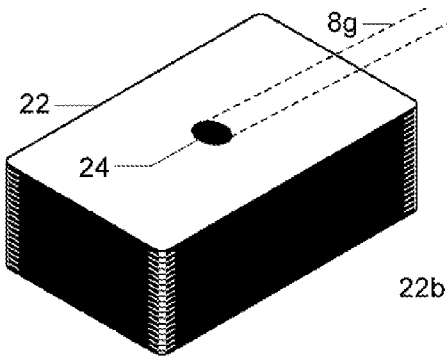

Figure 7

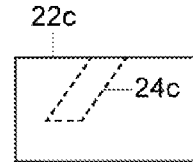
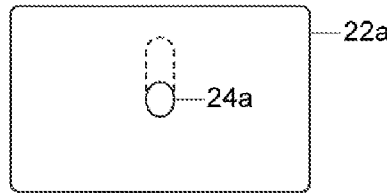

Figure 8

Figure 9

Figure 10

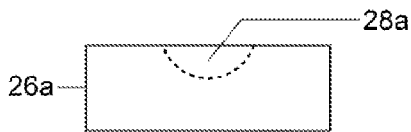
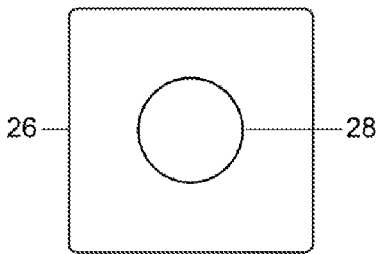

Figure 11

Figure 12

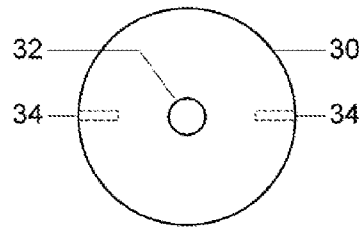
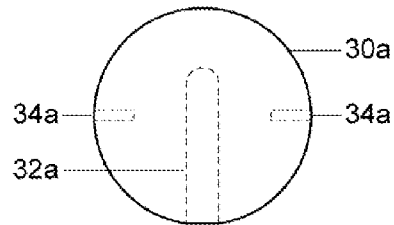

Figure 13



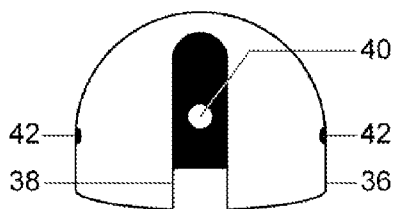

Figure 14

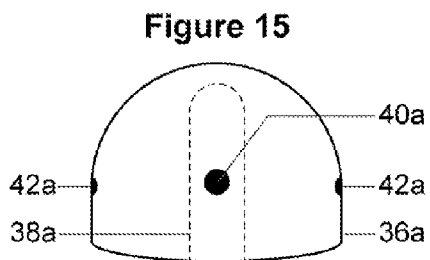

Figure 15

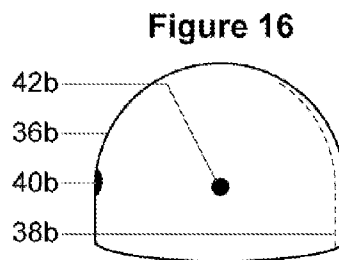

Figure 16

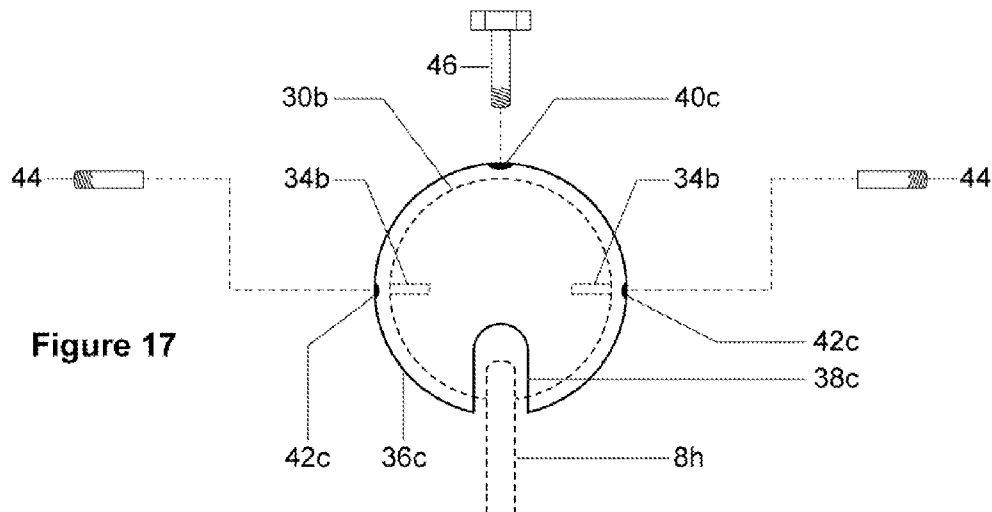

Figure 17

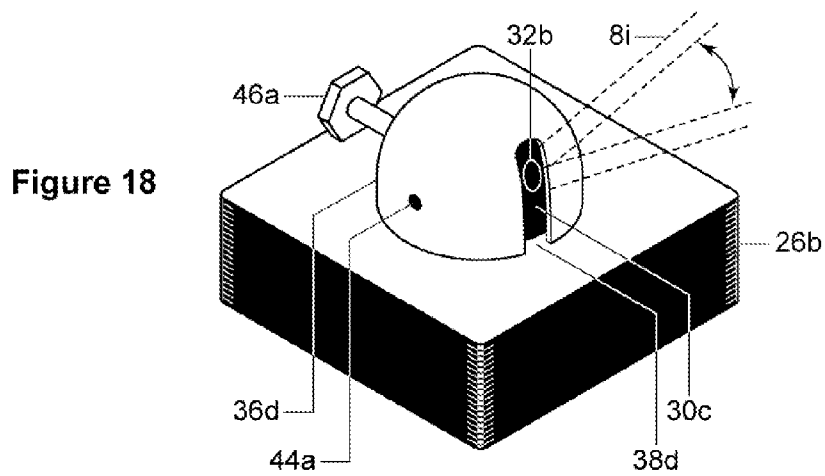

Figure 18

**TRANSITION PILOT**

**CROSS-REFERENCE TO RELATED APPLICATIONS**

**[0001]** Not Applicable.

**STATEMENT REGARDING FEDERALLY SPONSORED RESEARCH & DEVELOPMENT**

**[0002]** Not Applicable.

**REFERENCE TO A "MICROFICHE APPENDIX"**

**[0003]** Not Applicable.

**BACKGROUND OF THE INVENTION:**

**[0004]** (1) Field of the Invention

**[0005]** This invention relates to the golf swing and what is widely considered one of its more crucial moments: The transition from the top (and end) of the backswing to the beginning of the downswing.

**[0006]** (2) Description of the Related Art

**[0007]** One of the biggest misconceptions in golf is how to generate club head speed. From the top (and end) of the backswing, high handicap golfers tend to swing harder with their arms and hands, often resulting in powerless effort and an unbalanced swing. At this same crucial point in the golf swing, better skilled golfers engage the larger muscles of their lower bodies, consistently generating effortless power and increased club head speed, resulting in greater distance. The focus of the present invention is to train all users the importance of a slight lateral shift or "bump" of the hips, followed by a pivot through impact and toward the target.

**[0008]** Prior art reveals the need for a training device designed for golfers seeking immediate results to enhance their game. For instance, U.S. Pat. No. 4,355,809 to Swett (1982) offers a training device to improve the use of golf club irons by indicating whether the golfer tends to align his irons to hit a golf ball to the left or right of the true course. Includes a ball holder, a ball reference pointer, and vertical reference point; U.S. Pat. No. 4,688,800 to Lopez (1987) offers a golf swing guide having a generally triangular configuration that will only allow the golfer to swing correctly if he/she avoids any elbow contact with said guide; U.S. Pat. No. 5,474,299 to Romano (1995) offers an apparatus that allows a user to connect to a trainer with a rotor at a point near the users hands. The golfer then takes practice swings while linked to the rotor which allows for immediate feedback on the golfers swing; U.S. Pat. No. 5,599,240 to Feldmeier (1997) offers a guide rod, which can be positioned at varied angles with the base element. It allows for a user to determine how to swing their golf club and how they are moving in reference to the training device; U.S. Pat. No. 5,707,300 to May (1998) offers a golf swing training apparatus designed to allow a golfer to practice full swing motions and monitors the lateral and forward leg and knee motion during the full swing motion; U.S. Pat. No. 5,899,816 to Pearson (1999) offers a generally planar base from which a positioned golf ball may be driven and an optimum golf swing is achieved when no part of the device is struck during a complete golf swing; U.S. Pat. No. 6,464,597 to Hardesty (2002) offers a device that provides a reference point, which is used to assist golfers in monitoring different aspects of their golf swing. This apparatus is collapsible and includes a weighted element and legs to support the reference rod; U.S. Pat. No. 6,939,242 to Battersby (2005) offers a golf

apparatus with an elastically deformable guide pole that is bendable by a user into an arc. This arc has a curve that matches the arc of a desired swing of a golf club head; U.S. Pat. No. 7,275,998 to Jenkins (2007) offers a lightweight, collapsible golf swing apparatus for erection on ground and turf that promotes head restraint during the golf swing; U.S. Pat. No. 7,901,295 to Bush, III (2011) offers a golf swing guide that has a swing plane rod and a supporting base. This apparatus is intended to help a user swing using correct form regarding the rotation and the angle of the swing.

**[0009]** While the aforementioned items offer a multitude of approaches, all geared to enhance the golf swing, none of them specifically addresses the importance of a transition maneuver from the top (and end) of the backswing to the beginning of the downswing.

**BRIEF SUMMARY OF THE INVENTION**

**[0010]** In accordance with the present invention, an opportunity to teach the proper sequence of body movements from the top (and end) of the backswing is offered when a user is challenged to maneuver his/her hips beyond the position of a protruding device while executing/simulating a golf swing.

**[0011]** Accordingly, the object of this invention is to train its users the importance of engaging the larger muscles of the lower body, while the shoulders, arms and hands go along for the ride.

**[0012]** Accordingly, the object of this invention is to teach its users the importance of a slight lateral shift or "bump" of the hips, followed by a pivot through impact and toward the target.

**[0013]** Accordingly, an advantage of this invention is that the telescopic beam renders itself serviceable to users of all heights.

**[0014]** Accordingly, other advantages of this invention are for its users to generate effortless power, increase club head speed, and attain greater distance.

**[0015]** The objects and advantages of the present invention will become apparent from a consideration of the drawings and ensuing description.

**BRIEF DESCRIPTION OF THE SEVERAL VIEWS OF THE DRAWINGS**

**[0016]** FIG. 1 shows a plan view of my invention in its collapsed state (preferred embodiment).

**[0017]** FIG. 2 shows a plan view of my invention in its expanded state (preferred embodiment).

**[0018]** FIG. 3 shows two partial views of my invention.

**[0019]** FIG. 4 is a notional view of my invention in use.

**[0020]** FIG. 5 is a notional view of my invention in use.

**[0021]** FIG. 6 shows a perspective view of an optional accessory (alternative embodiment).

**[0022]** FIG. 7 is a top view of an optional accessory (alternative embodiment).

**[0023]** FIG. 8 is a front view of an optional accessory (alternative embodiment).

**[0024]** FIG. 9 is a side view of an optional accessory (alternative embodiment).

**[0025]** FIG. 10 is a top view of an optional weighted base (alternative embodiment).

**[0026]** FIG. 11 is a front view of an optional weighted base (alternative embodiment).

**[0027]** FIG. 12 is a front view of a spherical member (alternative embodiment).

- [0028] FIG. 13 is a top view of a spherical member (alternative embodiment).
- [0029] FIG. 14 is a front view of a hemispherical, domed outer casing member (alternative embodiment).
- [0030] FIG. 15 is a back view of a hemispherical, domed outer casing member (alternative embodiment).
- [0031] FIG. 16 is a side view of a hemispherical, domed outer casing member (alternative embodiment).
- [0032] FIG. 17 is a top view of a hemispherical, domed outer casing member (alternative embodiment).
- [0033] FIG. 18 shows a perspective view of an optional accessory (alternative embodiment).

DETAILED DESCRIPTION OF THE INVENTION

[0034] A preferred embodiment is presented in FIG. 1 (plan view), where a telescopic beam 8 has a ball 10 affixed to one end and a pointed, coaxial, coned tip 12 affixed to the other. In FIG. 2 (plan view), a telescopic beam 8 comprises a fixed number of tubular casings 8a to 8d inclusive, sequenced and fitted to one another, thus expandable to a plurality of lengths. FIG. 3 combines an exploded view with a functional view, illustrating how a pointed, coaxial, coned tip 12a interfaces with a telescopic beam 8e and detailing the coexistence of the pointed, coaxial, coned tip 12b with the telescopic beam 8f. FIG. 4 is a notional illustration depicting the position of the present invention 14 while its user 16 is in a golfer's address position. FIG. 5 is a notional illustration of the present invention 18 positioned in a sequential image recording of a user 20 in the midst of simulating a golf swing. In FIG. 6 (perspective view), a weighted base 22 offers a recessed cavity 24 for securing a telescopic beam 8g. FIG. 7 is a top view of the weighted base 22a and recessed cavity 24a. FIG. 8 is a front view of the weighted base 22b and recessed cavity 24b. FIG. 9 is a side view of the weighted base 22c and recessed cavity 24c. In FIG. 10, a top view depicts the position of a partially spherical, recessed socket 28 in a weighted base 26. FIG. 11 is a front view of the weighted base 26a with a partially spherical, recessed socket 28a. FIG. 12 presents the front view of a spherical member 30 having a large recessed cavity 32 perpendicular to two smaller recessed cavities 34, opposite one another. In operation, this spherical member is situated upon the partially spherical, recessed socket 28a of FIG. 11. FIG. 13 offers a top view of the spherical member 30a with a large recessed cavity 32a perpendicular to two smaller recessed cavities 34a. FIG. 14 presents the front view of a hemispherical, domed outer casing member 36, having an elongated, vertical opening 38 opposite a circular, threaded opening 40, both perpendicular to two smaller, circular, threaded openings 42. FIG. 15 is a back view of the hemispherical, domed outer casing member 36a, where a circular, threaded opening 40a is positioned perpendicularly to two smaller, circular, threaded openings 42a. FIG. 16 presents a side view of the hemispherical, domed outer casing member 36b, where a smaller, circular, threaded opening 42b and a larger, circular, threaded opening 40b are visible. In FIG. 17, an overhead, operational view illustrates how the hemispherical, domed outer casing member 36c brings functionality to all of its surrounding parts. To start, grub screws 44 become axles as they occupy smaller, recessed cavities 34b of spheri-

cal member 30b and are secured by small, threaded openings 42c. An elongated, vertical opening 38c leaves access for spherical member 30b and telescopic beam 8h to interface. Through a circular, threaded opening 40c at the rear, a threaded knob 46 abuts spherical member 30b. An alternative embodiment is presented in FIG. 18 (perspective view), where spherical member 30c oscillates on a vertical plane as it's secured by grub screws 44a. The spherical member's large, recessed cavity 32b is suitable for insertion of telescopic beam 8i and is accessible through an elongated, vertical opening 38d. An opportunity to secure the spherical member 30c in a fixed position is achieved when a threaded knob 46a enters a circular, threaded opening (not visible), abuts the spherical member 30c and is sufficiently tightened. The oscillation on a vertical plane promotes a multitude of projection angles for telescopic beam 8i, thus accommodating users of all heights.

What is claimed is:

1. A golf swing aid comprising a telescopic beam with a fixed number of tubular casings, sequenced and fitted to one another, thus expandable to a plurality of lengths.
2. A golf swing aid in claim 1, wherein a ball is affixed to one end.
3. A golf swing aid in claim 1, wherein a pointed, coaxial, coned tip is affixed to the other end.
4. A golf swing aid in claim 1, wherein the telescopic beam is made attachable to a weighted base having a recessed cavity.
5. A golf swing aid in claim 1, wherein the telescopic beam is made attachable to a weighted base comprising: a lower-most member having a partially spherical, recessed socket; a spherical member having two small recessed cavities positioned opposite one another, yet perpendicular to an additional larger recessed cavity; and an upper-most hemispherical, domed, outer casing member having an elongated, vertical opening and a smaller, threaded opening opposite one another, both perpendicular to two smaller, circular, threaded openings; a threaded knob; and two grub screws.
6. A method to train users to engage the larger muscles of their lower bodies while executing/simulating a golf swing comprising the steps of:
  - (a) providing a protruding device, perhaps as described in claims 1 thru 5;
  - (b) instructing users to strategically position said protruding device in the lower midriff area of the user's body while at an address position; and
  - (c) challenging the user to maneuver his/her hips beyond the position of said protruding device while executing/simulating a golf swing; thus
  - (d) inciting a slight lateral shift or "bump" of the hips, followed by a pivot through impact and toward the target; furthermore
  - (e) attesting that a high volume of repetition is conducive to committing the newly learned maneuver to muscle memory; and thereby
  - (f) advancing a process to train users to engage the larger muscles of their lower bodies while executing/simulating a golf swing.

\* \* \* \* \*