

(19)



(11)

EP 3 606 702 B1

(12)

EUROPEAN PATENT SPECIFICATION

(45) Date of publication and mention of the grant of the patent:
12.02.2025 Bulletin 2025/07

(21) Application number: **18794567.0**

(22) Date of filing: **04.05.2018**

(51) International Patent Classification (IPC):
B25D 16/00 (2006.01) B25F 5/00 (2006.01)

(52) Cooperative Patent Classification (CPC):
B25D 16/006; B25D 16/003; B25D 2216/0023; B25D 2216/0038; B25D 2216/0069; B25D 2250/165; B25D 2250/221

(86) International application number:
PCT/US2018/031017

(87) International publication number:
WO 2018/204741 (08.11.2018 Gazette 2018/45)

(54) **HAMMER DRILL**

BOHRHAMMER

PERCEUSE A PERCUSSION

(84) Designated Contracting States:
AL AT BE BG CH CY CZ DE DK EE ES FI FR GB GR HR HU IE IS IT LI LT LU LV MC MK MT NL NO PL PT RO RS SE SI SK SM TR

(30) Priority: **05.05.2017 US 201762501962 P**
11.07.2017 US 201762531054 P

(43) Date of publication of application:
12.02.2020 Bulletin 2020/07

(60) Divisional application:
24218470.3 / 4 497 546

(73) Proprietor: **Milwaukee Electric Tool Corporation**
Brookfield, WI 53005 (US)

(72) Inventors:
• **DUNCAN, Ian**
Milwaukee, WI 53208 (US)
• **DEDRICKSON, Ryan A.**
Sussex, WI 53089 (US)

(74) Representative: **Novagraaf Group**
Chemin de l'Echo 3
1213 Onex / Geneva (CH)

(56) References cited:
WO-A2-2012/061176 DE-U1- 20 305 853
US-A- 5 458 206 US-A1- 2004 026 099
US-A1- 2009 126 957 US-A1- 2012 285 712
US-A1- 2012 293 099 US-A1- 2014 110 140
US-A1- 2014 110 140

EP 3 606 702 B1

Note: Within nine months of the publication of the mention of the grant of the European patent in the European Patent Bulletin, any person may give notice to the European Patent Office of opposition to that patent, in accordance with the Implementing Regulations. Notice of opposition shall not be deemed to have been filed until the opposition fee has been paid. (Art. 99(1) European Patent Convention).

Description

CROSS-REFERENCE TO RELATED APPLICATIONS

5 **[0001]** This application claims priority to co-pending U.S. Provisional Patent Application No. 62/501,962, filed on May 5, 2017. This application also claims priority to co-pending U.S. Provisional Patent Application 62/531,054, filed on July 11, 2017.

FIELD OF THE INVENTION

10 **[0002]** The present invention relates to a hammer drill according to the preamble of claim 1 as well as to a hammer drill according to the preamble of claim 13. Such a hammer drill is known from US 5 458 206 A.

BACKGROUND OF THE INVENTION

15 **[0003]** Some power tools include mode selector collars and clutch-setting selector collars to respectively select modes of operation and clutch settings for that power tool. For instance, mode selector collars are sometimes provided on hammer drills to allow an operator to cycle between "hammer drill," "drill only," and "screwdriver" modes of the hammer drill. Clutch-setting selector collars are sometimes provided on hammer drills to allow an operator to select different clutch settings while in the "screwdriver" mode of operation.

20 **[0004]** According to its abstract, US 5 458 206 A describes a power tool that has an application mechanism for connection to the output of an epicyclic gearbox provided with a torque control ring. The mechanism has a body journalling a chuck spindle. Outside the body is a clutch control arrangement comprising balls pressed against the torque control ring by individual springs controlled by a control ring threaded on the body. The mechanism includes a hammer arrangement having rotary and fixed ratchet plates and cam ring operable to engage and separate the plates by a lever which projects between the springs.

25 **[0005]** According to its abstract, US 2014/110140 A1 describes a hammer drill that includes a housing, a first ratchet fixed to the housing, a spindle rotatably supported by the housing about an axis, and a second ratchet coupled for co-rotation with the spindle. The second ratchet is engageable with the first ratchet in response to rearward displacement of the spindle to impart a hammering action on the spindle. The hammer drill further includes a thrust bearing having an arm extending away from the axis, and a selector ring having a post extending toward the arm. The selector ring is rotatable between a first position in which the post is engageable with the arm to limit the rearward displacement of the spindle and prevent engagement of the first and second ratchets, and a second position in which the post is misaligned with the arm to permit the rearward displacement of the spindle and engagement of the first and second ratchets.

35 SUMMARY OF THE INVENTION

40 **[0006]** Aspects of the present invention are defined by the appended independent claims. Preferred embodiments of the present invention are defined by the appended dependent claims. According to the present invention there is provided a hammer drill according to claim 1 comprising a drive mechanism including an electric motor and a transmission, a housing enclosing at least a portion of the drive mechanism, a spindle rotatable in response to receiving torque from the drive mechanism, a first ratchet coupled for co-rotation with the spindle, a second ratchet rotationally fixed to the housing, and a hammer lockout mechanism adjustable between a first mode and a second mode. The hammer locking mechanism includes a detent movable between a locking position and an unlocking position. The hammer drill further comprises a clutch adjustable between a first state in which a torque output of the spindle is a predetermined maximum value, and a second state in which torque output of the spindle is limited to a value less than the predetermined maximum value. The hammer drill further comprises a collar rotatably coupled to the housing and movable between a first rotational position in which the hammer lockout mechanism is in the first mode and the clutch is in the first state, a second rotational position in which the hammer lockout mechanism is in the second mode and the clutch is in the first state, and a third rotational position in which the hammer lockout mechanism is in the second mode and the clutch is in the second state. In the first mode the detent is moveable from the locking position to the unlocking position, such that the spindle is movable relative to the housing in response to contact with a workpiece, causing the first and second ratchets to engage. In the second mode the detent is prevented from moving from the locking position to the unlocking position, such that the spindle is blocked by the detent from moving relative to the housing in response to contact with a workpiece and a gap is maintained between the

55 **[0007]** According to the present invention there is also provided a hammer drill according to claim 13 comprising a drive mechanism including an electric motor and a transmission, a housing enclosing at least a portion of the drive mechanism, a spindle arranged in the housing and rotatable in response to receiving torque from the drive mechanism, a first ratchet

arranged in the housing and coupled for co-rotation with the spindle, a second ratchet rotationally fixed to the housing, a hammer lockout mechanism including a plurality of apertures in the housing and a ball arranged in each of the apertures, and a clutch adjustable between a first state in which a torque output of the spindle is a predetermined maximum value, and a second state in which torque output of the spindle is limited to a value less than the predetermined maximum value. The hammer drill further comprises a collar rotatably coupled to the housing and including a plurality of recesses. The collar is moveable between a first rotational position, in which each of the recesses is aligned with one of the apertures and the clutch is in the first state, a second rotational position, in which at least one recess is not aligned with any of the apertures and the clutch is in the first state, and a third rotational position, in which at least one recess is not aligned with any of the apertures and the clutch is in the second state. Each of the balls is moveable within its respective aperture between an unlocking position, in which the ball is at least partially received in one of the recesses of the collar, and a locking position, in which the ball is not received in any of the recesses of the collar. When the collar is in the first rotational position, the balls are each moveable from the locking position to the unlocking position, such that the spindle is movable relative to the housing in response to an axial force applied to the spindle in a rearward direction, allowing the first and second ratchets to engage. When the collar is in the second and third rotational positions, at least one ball is prevented from moving from the locking position to the unlocking position, such that the at least one ball in the locking position blocks the spindle from moving relative to the housing in response to the axial force applied to the spindle in the rearward direction and a gap is maintained between the first and second ratchets.

[0008] Described herein in another implementation is a hammer drill comprising a drive mechanism including an electric motor and a transmission, a housing enclosing at least a portion of the drive mechanism, a spindle rotatable in response to receiving torque from the drive mechanism, a first ratchet coupled for co-rotation with the spindle, a second ratchet rotationally fixed to the housing, and a hammer lockout mechanism adjustable between a first mode in which the spindle is movable relative to the housing in response to an axial force applied to the spindle in a rearward direction, causing the first and second ratchets to engage, and a second mode in which the spindle is inhibited from moving relative to the housing in response to the axial force applied to the spindle in the rearward direction, maintaining a gap between the first and second ratchets. The hammer drill further comprises an electronic clutch adjustable between a first state in which a torque output of the electric motor is a predetermined maximum value, and a second state in which torque output of the electric motor is limited to a value less than the predetermined maximum value. The hammer drill also comprises a collar rotatably coupled to the housing and movable between a first rotational position in which the hammer lockout mechanism is in the first mode and the electronic clutch is in the first state, a second rotational position in which the hammer lockout mechanism is in the second mode and the electronic clutch is in the first state, and a third rotational position in which the hammer lockout mechanism is in the second mode and the electronic clutch is in the second state. The collar is rotatable in either a clockwise or a counter-clockwise direction to switch between the first and third rotational positions without passing through the second rotational position.

[0009] Described herein in yet another implementation is a hammer drill comprising a drive mechanism including an electric motor and a transmission, a housing enclosing at least a portion of the drive mechanism, a spindle rotatable in response to receiving torque from the drive mechanism, a first ratchet coupled for co-rotation with the spindle, a second ratchet axially and rotationally fixed to the housing, the second ratchet defining a pocket on a side of the second ratchet that is opposite the first ratchet, a first bearing supporting a front portion of the spindle and radially positioned between the housing

and the spindle, and a second bearing supporting a rear portion of the spindle and at least partially positioned in the pocket.

[0010] Other features and aspects of the invention will become apparent by consideration of the following detailed description and accompanying drawings.

BRIEF DESCRIPTION OF THE DRAWINGS

[0011]

FIG. 1 is a perspective view of a portion of a hammer drill in accordance with an embodiment of the invention.

FIG. 2 is an enlarged, exploded view of a front portion of the hammer drill of FIG. 1, with a collar rendered transparent to illustrate a selector ring.

FIG. 3 is a longitudinal cross-sectional view of the hammer drill of FIG. 1.

FIG. 4 is an enlarged view of the hammer drill of FIG. 3, with portions removed, illustrating a hammer lock-out mechanism in a disabled mode.

FIG. 5 is a lateral cross-sectional view of the hammer lock-out mechanism of FIG. 4 coinciding with a first rotational

position of a collar of the hammer drill of FIG. 1.

FIG. 6 is an enlarged view of the hammer drill of FIG. 3, with portions removed, illustrating the hammer lock-out mechanism in an enabled mode.

5 FIG. 7 is a lateral cross-sectional view of the hammer lock-out mechanism of FIG. 6 coinciding with a second rotational position of the collar.

10 FIG. 8 is a lateral cross-sectional view of the hammer lock-out mechanism coinciding with a third rotational position of the collar.

FIG. 9 is a lateral cross-sectional view of the hammer lock-out mechanism coinciding with a fourth rotational position of the collar.

15 FIG. 10 is a lateral cross-sectional view of the hammer lock-out mechanism coinciding with a fifth rotational position of the collar.

FIG. 11 is a lateral cross-sectional view of the hammer lock-out mechanism coinciding with a sixth rotational position of the collar.

20 FIG. 12 is a lateral cross-sectional view of the hammer lock-out mechanism coinciding with a seventh rotational position of the collar.

25 FIG. 13 is a lateral cross-sectional view of the hammer lock-out mechanism coinciding with an eighth rotational position of the collar.

FIG. 14 is a lateral cross-sectional view of the hammer lock-out mechanism coinciding with a ninth rotational position of the collar.

30 FIG. 15 is a lateral cross-sectional view of the hammer lock-out mechanism coinciding with a tenth rotational position of the collar.

FIG. 16 is a lateral cross-sectional view of the hammer lock-out mechanism coinciding with a eleventh rotational position of the collar.

35 FIG. 17 is a lateral cross-sectional view of the hammer lock-out mechanism coinciding with a twelfth rotational position of the collar.

FIG. 18 is a lateral cross-sectional view of the hammer lock-out mechanism coinciding with a thirteenth rotational position of the collar.

40 FIG. 19 is a lateral cross-sectional view of the hammer lock-out mechanism coinciding with a fourteenth rotational position of the collar.

45 FIG. 20 is a lateral cross-sectional view of the hammer lock-out mechanism coinciding with a fifteenth rotational position of the collar.

FIG. 21 is a lateral cross-sectional view of the hammer lock-out mechanism coinciding with a sixteenth rotational position of the collar.

50 FIG. 22 is a lateral cross-sectional view of the hammer lock-out mechanism coinciding with a seventeenth rotational position of the collar.

55 FIG. 23 is a lateral cross-sectional view of the hammer lock-out mechanism coinciding with an eighteenth rotational position of the collar.

FIG. 24 is a lateral cross-sectional view of the hammer lock-out mechanism coinciding with a nineteenth rotational position of the collar.

EP 3 606 702 B1

FIG. 25 is a lateral cross-sectional view of the hammer lock-out mechanism coinciding with a twentieth rotational position of the collar.

5 FIG. 26 is a lateral cross-sectional view of another embodiment of a hammer lock-out mechanism illustrating the hammer lock-out mechanism in a disabled mode, coinciding with a first rotational position of a collar of the hammer drill of FIG. 1.

10 FIG. 27 is a lateral cross-sectional view of the hammer lock-out mechanism of FIG. 26 illustrating the hammer lock-out mechanism in an enabled mode, coinciding with a second rotational position of the collar.

15 FIG. 28 is a lateral cross-sectional view of the hammer lock-out mechanism of FIG. 26 coinciding with a third rotational position of the collar.

20 FIG. 29 is a lateral cross-sectional view of the hammer lock-out mechanism of FIG. 26 coinciding with a fourth rotational position of the collar.

25 FIG. 30 is a lateral cross-sectional view of the hammer lock-out mechanism of FIG. 26 coinciding with a fifth rotational position of the collar.

30 FIG. 31 is a lateral cross-sectional view of the hammer lock-out mechanism of FIG. 26 coinciding with a sixth rotational position of the collar.

35 FIG. 32 is a lateral cross-sectional view of the hammer lock-out mechanism of FIG. 26 coinciding with a seventh rotational position of the collar.

40 FIG. 33 is a lateral cross-sectional view of the hammer lock-out mechanism of FIG. 26 coinciding with an eighth rotational position of the collar.

45 FIG. 34 is a lateral cross-sectional view of the hammer lock-out mechanism of FIG. 26 coinciding with a ninth rotational position of the collar.

50 FIG. 35 is a lateral cross-sectional view of the hammer lock-out mechanism of FIG. 26 coinciding with a tenth rotational position of the collar.

55 FIG. 36 is a lateral cross-sectional view of the hammer lock-out mechanism of FIG. 26 coinciding with a eleventh rotational position of the collar.

60 FIG. 37 is a lateral cross-sectional view of the hammer lock-out mechanism of FIG. 26 coinciding with a twelfth rotational position of the collar.

65 FIG. 38 is a lateral cross-sectional view of the hammer lock-out mechanism of FIG. 26 coinciding with a thirteenth rotational position of the collar.

70 FIG. 39 is a lateral cross-sectional view of the hammer lock-out mechanism coinciding with a fourteenth rotational position of the collar.

75 FIG. 40 is a lateral cross-sectional view of the hammer lock-out mechanism coinciding with a fifteenth rotational position of the collar.

80 FIG. 41 is a lateral cross-sectional view of the hammer lock-out mechanism coinciding with a sixteenth rotational position of the collar.

85 FIG. 42 is a longitudinal cross-sectional view of another embodiment of the hammer drill of FIG. 1.

90 FIG. 43 is an enlarged, exploded view of a front portion of the hammer drill of FIG. 42, with portions removed.

95 FIG. 44 is an enlarged, exploded view of a front portion of the hammer drill of FIG. 42, with portions removed.

FIG. 45 is a rear perspective view of a collar and a lockout ring of the hammer drill of FIG. 42.

FIG. 46 is a lateral cross-sectional view of a hammer lock-out mechanism coinciding with a first rotational position of a collar of the hammer drill of FIG. 42.

5 FIG. 47 is an enlarged view of the hammer drill of FIG. 42, with portions removed, illustrating the hammer lock-out mechanism in a disabled mode coinciding with the first rotational position of the collar of FIG. 46.

10 FIG. 48 is a lateral cross-sectional view of the hammer lock-out mechanism coinciding with a second rotational position of the collar of the hammer drill of FIG. 42.

FIG. 49 is an enlarged view of the hammer drill of FIG. 42, with portions removed, illustrating the hammer lock-out mechanism in an enabled mode coinciding with the second rotational position of the collar of FIG. 48.

15 FIG. 50 is a perspective view of a portion of a transmission housing of the hammer drill of FIG. 42.

[0012] Before any embodiments of the invention are explained in detail, it is to be understood that the phraseology and terminology used herein is for the purpose of description and should not be regarded as limiting.

20 DETAILED DESCRIPTION

[0013] As shown in FIGS. 1-3, a rotary power tool, in this embodiment a hammer drill 10, includes a housing 12, a drive mechanism 14 and a spindle 18 rotatable in response to receiving torque from the drive mechanism 14. As shown in FIG. 3, the drive mechanism 14 includes an electric motor 22 and a multi-speed transmission 26 between the motor 22 and the spindle 18. The drive mechanism 14 is at least partially enclosed by a transmission housing 30. As shown in FIGS. 1 and 3, a chuck 34 is provided at the front end of the spindle 18 so as to be co-rotatable with the spindle 18. The chuck 34 includes a plurality of jaws 38 configured to secure a tool bit or a drill bit (not shown), such that when the drive mechanism 14 is operated, the bit can perform a rotary and/or percussive action on a fastener or workpiece. The hammer drill 10 includes a pistol grip handle 36, a trigger 39 for activating the motor 22, and an auxiliary handle 40 that can be selectively removed from the transmission housing 30. The hammer drill 10 may be powered by an on-board power source such as a battery 41 or a remote power source (e.g., an alternating current source) via a cord (not shown).

[0014] With reference to FIGS. 2 and 3, the hammer drill 10 includes a first ratchet 42 coupled for co-rotation with the spindle 18 and a second ratchet 46 axially and rotationally fixed to the transmission housing 30. In some embodiments, the second ratchet 46 is rotationally fixed to the transmission housing 30 but allowed to translate axially with respect to the transmission housing 30. As shown in FIGS. 3, 4 and 6, a first bearing 50 with an edge 54 is radially positioned between the transmission housing 30 and the spindle 18 and supports a front portion 58 of the spindle 18. In the illustrated embodiment, the edge 54 is concave, but in other embodiments, the edge 54 may be chamfered or a combination of chamfered and concave. As shown in FIGS. 3, 4 and 6, the front portion of the spindle 58 includes a radially outward-extending shoulder 60 adjacent to and axially in front of the bearing 50, such that the spindle 18 is not capable of translating axially rearward unless the bearing 50 also translates axially rearward. In some embodiments, the bearing 50 is omitted and the edge 54 is located on the spindle 18.

[0015] As shown in FIG. 3, the second ratchet 46 includes a bearing pocket 62 defined in a rear end of the second ratchet 46. A second bearing 66 is at least partially positioned in the bearing pocket 62 and supports a rear portion 70 of the spindle 18. In the illustrated embodiment, the second bearing 66 is wholly received in the bearing pocket 62, but in other embodiments the second bearing 66 may at least partially extend from the bearing pocket 62. By incorporating the bearing pocket 62 in the second ratchet 46, the second bearing 66 is arranged about the rear portion 70 of the spindle 18 in a nested relationship within the second ratchet 46, thereby reducing the overall length of the hammer drill 10 while also supporting rotation of the spindle 18. In other embodiments (not shown), the second ratchet 46 does not include a bearing pocket and the second bearing 66 is press-fit to the transmission housing 30.

[0016] With reference to FIGS. 1-7, the hammer drill 10 includes a collar 74 that is rotatably adjustable by an operator of the hammer drill 10 to shift between "hammer drill," "drill-only," and "screwdriver" modes of operation, and to select a particular clutch setting when in "screwdriver mode." Thus, the collar 74 is conveniently provided as a single collar that can be rotated to select different operating modes of the hammer drill 10 and different clutch settings. As shown in FIGS. 2 and 3, the hammer drill 10 also includes an electronic clutch 78 capable of limiting the amount of torque that is transferred from the spindle 18 to a fastener (i.e., when in "screwdriver mode") by deactivating the motor 22 in response to a detected torque threshold or limit. In some embodiments, the torque threshold is based on a detected current that is mapped to or indicative of an output torque of the motor. The electronic clutch 78 includes a printed circuit board ("PCB") 82 coupled to the transmission housing 30 and a wiper (not shown), which is coupled for co-rotation with the collar 74. The PCB 82 includes a

plurality of electrical pads 86 which correspond to different clutch settings of the hammer drill 10. In other embodiments, instead of a wiper moving against pads 86, one or more of a potentiometer, hall sensor, or inductive sensor could be used for selecting the different clutch settings or mode settings.

[0017] The hammer drill 10 also includes a hammer lockout mechanism 90 (FIGS. 4-7) for selectively inhibiting the first and second ratchets 42, 46 from engaging when the hammer drill 10 is in a "screwdriver mode" or a "drill-only mode." The hammer lockout mechanism 90 includes a selector ring 94 coupled for co-rotation with and positioned inside the collar 74, and a plurality of balls 98 situated within corresponding radial apertures A1, A2, A3, A4, and A5 asymmetrically positioned around an annular portion 102 of the transmission housing 30. As shown in FIGS. 2, 5 and 7-25, the selector ring 94 includes a plurality of recesses R1, R2, R3, R4, and R5 asymmetrically positioned about an inner periphery 104 of the selector ring 94. The number of recesses R1-R5 corresponds to the number of apertures A1-A5 and the number of balls 98 within the respective apertures A1-A5.

[0018] In the illustrated embodiment, five apertures A1-A5, each containing a detent, such as a ball 98, are located in the transmission housing 30 and five recesses R1-R5 are defined in the selector ring 94. However, in other embodiments, the hammer lockout mechanism 90 could employ more or fewer apertures, balls, and recesses. As shown in FIGS. 5 and 7, the five apertures A1-A5 are approximately located at 0 degrees, 55 degrees, 145 degrees, 221 degrees, and 305 degrees, respectively, measured in a counterclockwise direction from an oblique plane 105 containing a longitudinal axis 108 of the hammer drill 10 and bisecting aperture A1. As shown in FIGS. 4 and 6, the first ratchet 42 and the first bearing 50 are set within a cylindrical cavity 106 defined within the annular portion 102 of the transmission housing 30, and the selector ring 94 is radially arranged between the annular portion 102 and the collar 74, surrounding the apertures A1-A5.

[0019] In operation, as shown in FIGS. 4 and 5 when the collar 74 and ring 94 are rotated together to a position corresponding to a "hammer drill" mode, all five apertures A1-A5 are aligned with all five recesses R1-R5 in the selector ring 94, respectively. Therefore, when the bit held by the jaws 38 contacts a workpiece, the normal force of the workpiece pushes the bit axially rearward, i.e., away from the workpiece. The axial force experienced by the tool bit is applied through the spindle 18 in a rearward direction, causing the spindle 18 to move axially rearward, thus forcing the first bearing 50 to move rearward and the edge 54 of the first bearing 50 to displace each of the balls 98 situated in the respective apertures A1-A5 radially outward to a "unlocking position", in which the balls 98 are partially received into the recesses R1-R5, thereby disabling the hammer lockout mechanism 90. Thus, the first ratchet 42 is permitted to engage with the second ratchet 46 to impart reciprocation to the spindle 18 as it rotates.

[0020] However, when the collar 74 and selector ring 94 are incrementally rotated (e.g., by 18 degrees) in a counterclockwise direction to the second rotational position shown in FIGS. 6 and 7, none of the apertures A1-A5 are aligned with the recesses R1-R5. Thus, in this position of the collar 74 and selector ring 94, the balls 98 in the respective apertures A1-A5 are prevented from being radially displaced into the recesses R1-R5 in response to the tool bit contacting a workpiece and the spindle 18 and bearing 50 attempting to move axially rearward. Rather, the edge 54 of the first bearing 50 presses against the balls 98, which in turn abut against the inner periphery 104 of the selector ring 94 and are inhibited from displacing radially outward. In other words, the balls 98 remain in "locking positions" and each ball 98 is prevented from moving from the locking position to the unlocking position. Thus, the spindle 18 is blocked by the balls 98 in their locking positions, via the first bearing 50, and therefore the spindle 18 is prevented from moving rearward, maintaining a gap 110 between the first and second ratchets 42, 46. Thus, in the second rotational position of the collar 74 and the selector ring 94, the hammer lockout mechanism 90 is enabled, preventing the spindle 18 from reciprocating in an axial manner as it is rotated by the drive mechanism 14, operating the hammer drill 10 in a "drill only" mode.

[0021] There are a total of twenty different positions between which the collar 74 and selector ring 94 can rotate, such that the collar 74 is rotated 18 degrees between each of the positions. The wiper is in electrical and sliding contact with the PCB 82 as the collar 74 is rotated between each of the twenty positions. Depending upon which of the electrical pads 86 on the PCB 82 the wiper contacts, the electronic clutch 78 adjusts which clutch setting to apply to the motor 22. In the "hammer drill" mode and the "drill only" mode coinciding with the first and second rotational positions of the collar 74 and selector ring 94, respectively, the electronic clutch 78 operates the motor 22 to output torque at a predetermined maximum value to the spindle 18. In some embodiments, the predetermined maximum value of torque output by the motor 22 may coincide with the maximum rated torque of the motor 22.

[0022] As shown in FIG. 5 and the Table below, the "hammer drill" position of the collar 74 corresponds to a "0 degree" or "first rotational position" position of the collar 74, in which the recesses R1, R2, R3, R4, R5 of the selector ring 94 are respectively and approximately located at 0, 55, 145, 221, and 305 degrees counterclockwise from the plane 105, such that the apertures A1, A2, A3, A4, A5 are thereby aligned. When the collar 74 is rotated 18 degrees counterclockwise from the "hammer drill" position to the "drill only" or "second rotational position" as shown in FIG. 7, the recesses R1, R2, R3, R4, R5 are respectively and approximately located at 18 degrees, 73 degrees, 163 degrees, 239 degrees, and 323 degrees counterclockwise from the plane 105.

[0023] As shown in the Table below and in FIGS. 8-25, the operator may continue to cycle through eighteen additional rotational positions of the collar 74, each corresponding to a different clutch setting in "screwdriver mode", by incrementally rotating the collar 74 counterclockwise by 18 degrees each time. The first clutch setting (FIG. 8) provides a torque limit that

EP 3 606 702 B1

is slightly less than the predetermined maximum value of torque output by the motor 22 available in the "hammer drill" mode or the "drill only" mode. As the clutch setting number numerically increases, the torque threshold applied to the motor 22 decreases, with the eighteenth clutch setting (shown in FIG. 25) providing the lowest torque limit to the motor 22.

[0024] As can be seen in FIGS. 5 and 7-25, and the Table below, the "hammer drill" position in FIG. 5 is the only position in which all five apertures A1-A5 are aligned with all five recesses R1-R5, thereby disabling the hammer lockout mechanism 90 as described above. In every other setting of the collar 74 and selector ring 94, no more than two of any of the apertures A1-A5 are aligned with the recesses R1-R5. Therefore, in "drill-only" mode (FIG. 7) and "screwdriver mode" (FIGS. 8-25, clutch settings 1-18), at least three balls 98 inhibit the rearward movement of the spindle 18, via the first bearing 50, thereby enabling the hammer lockout mechanism 90 and preventing axial reciprocation of the spindle 18 as it rotates.

HAMMER LOCKOUT MECHANISM 90 (FIGS 2-25)

[0025]

Degrees of collar rotation	A1	A2	A3	A4	A5	Balls in recesses	Mode Setting	Clutch Setting	FIG No.
	Aperture is aligned with which recess?								
0	R1	R2	R3	R4	R5	5	Hammer Drill	Max Torque	5
18	-	-	-	-	-	0	Drill Only	Max Torque	7
36	-	-	-	-	-	0	Screwdriver	1	8
54	R5	R1	-	-	-	2	Screwdriver	2	9
72	-	-	-	R3	R4	2	Screwdriver	3	10
90	-	-	R2	-	R4	2	Screwdriver	4	11
108	-	R5	-	-	-	1	Screwdriver	5	12
126	-	-	-	-	-	0	Screwdriver	6	13
144	R4	-	R1	-	-	2	Screwdriver	7	14
162	-	-	-	R2	R3	2	Screwdriver	8	15
180	-	-	-	-	-	0	Screwdriver	9	16
198	-	R4	R5	-	-	2	Screwdriver	10	17
216	R3	-	-	R1	-	2	Screwdriver	11	18
234	-	-	-	-	-	0	Screwdriver	12	19
252	-	-	-	-	R2	1	Screwdriver	13	20
270	-	R3	-	R5	-	2	Screwdriver	14	21
288	-	-	R4	R5	-	2	Screwdriver	15	22
306	R2	-	-	-	R1	2	Screwdriver	16	23
324	-	-	-	-	-	0	Screwdriver	17	24
342	-	-	-	-	-	0	Screwdriver	18	25
360	R1	R2	R3	R4	R5	5	Hammer Drill	Max Torque	5

[0026] To adjust the hammer drill 10 between "screwdriver" mode, "drill only" mode, and "hammer drill" mode, the collar 74 may be rotated a full 360 degrees and beyond in a single rotational direction, clockwise or counterclockwise, without any stops which would otherwise limit the extent to which the collar 74 may be rotated. Therefore, if the operator is using the hammer drill 10 in "screwdriver mode" on the eighteenth clutch setting (FIG. 25), the operator needs only to rotate the collar 74 counterclockwise by an additional 18 degrees to switch the hammer drill 10 into "hammer drill" mode, rather than rotating the collar 74 in an opposite (clockwise) direction back through clutch settings 17 to 1 and "drill only" mode.

[0027] A different embodiment of a hammer lockout mechanism 90a is shown in FIGS. 26-41. In the embodiment of FIGS. 26-41, the five apertures A1-A5 are approximately located at 0 degrees, 72 degrees, 156 degrees, 203 degrees, and 300 degrees, respectively, measured in a clockwise direction from a vertical plane 112 containing the longitudinal axis 108

of the hammer drill 10 and bisecting aperture A1.

[0028] In operation, as shown in FIG. 26 when the collar 74a and ring 94a are rotated together to a first position corresponding to a "hammer drill" mode, all five apertures A1-A5 are aligned with all five recesses R1-R5 in the selector ring 94a, respectively. Therefore, when the bit held by the jaws 38 contacts a workpiece, the normal force of the workpiece pushes the bit axially rearward, i.e., away from the workpiece. The axial force experienced by the tool bit is applied through the spindle 18 in a rearward direction, causing the spindle 18 to move axially rearward, thus forcing the first bearing 50 to move rearward and the edge 54 of the first bearing 50 to displace each of the balls 98a situated in the respective apertures A1-A5 radially outward to a "unlocking position", in which the balls 98a are partially received into the recesses R1-R5, thereby disabling the hammer lockout mechanism 90a. Thus, the first ratchet 42 is permitted to engage with the second ratchet 46 to impart reciprocation to the spindle 18 as it rotates.

[0029] However, when the collar 74a and selector ring 94a are rotated 36 degrees in a counterclockwise direction to the second rotational position shown in FIG. 27, only aperture A3 is aligned with the recess R4. Thus, in this second position of the collar 74a and selector ring 94a, the balls 98a in the respective apertures A1, A2, A4 and A5 are prevented from being radially displaced into any of the other recesses R1, R2, R3 and R5 in response to the tool bit contacting a workpiece, and the spindle 18 and bearing 50 attempting to move axially rearward. Rather, the edge 54 of the first bearing 50 presses against the balls 98a, which in turn abut against the inner periphery 104a of the selector ring 94a and are inhibited from displacing radially outward. In other words, the balls 98 remain in "locking positions" and each ball 98 is prevented from moving from the locking position to the unlocking position. Thus, the spindle 18 is blocked by the balls 98a in their locking positions, via the first bearing 50, and therefore the spindle 18 is prevented from moving rearward, maintaining a gap 110 between the first and second ratchets 42, 46. Thus, in the second rotational position of the collar 74 and the selector ring 94, the hammer lockout mechanism 90a is enabled, preventing the spindle 18 from reciprocating in an axial manner as it is rotated by the drive mechanism 14, operating the hammer drill 10 in a "drill only" mode.

[0030] When the collar 74a and selector ring 94a are again rotated 36 degrees in a counterclockwise direction to the third rotational position shown in FIG. 28, only aperture A1 is aligned with the recess R2. Thus, in this position of the collar 74a and selector ring 94a, the balls 98a in the respective apertures A2, A3, A4 and A5 are prevented from being radially displaced into any of the other recesses R1, R3, R4 and R5 in response to the spindle 18 contacting a workpiece (via the chuck 34 and an attached drill or tool bit). Thus, in the third rotational position of the collar 74a and the selector ring 94a, the hammer lockout mechanism 90a is enabled, preventing the spindle 18 from reciprocating in an axial manner as it is rotated by the drive mechanism 14, operating that hammer drill 10 in a "screwdriver mode" with the first clutch setting.

[0031] In the embodiment of hammer lockout mechanism 90a illustrated in FIGS. 26-41, there are a total of sixteen different positions between which the collar 74a and selector ring 94a can rotate. As described above, the collar 74a rotates 36 degrees counterclockwise from the first position (FIG. 26) to the second position (FIG. 27), and 36 degrees counterclockwise from the second position (FIG. 27) to the third position (FIG. 28). Subsequently, the collar 74a is incrementally rotated 18 degrees each time to incrementally switch to the fourth and through the sixteenth positions. The wiper is in electrical and sliding contact with the PCB 82 as the collar 74a is rotated between each of the sixteen positions. Depending upon which of the electrical pads 86 on the PCB 82 the wiper contacts, the electronic clutch 78 adjusts which clutch setting to apply to the motor 22. In the "hammer drill" mode and the "drill only" mode coinciding with the first and second rotational positions of the collar 74a and selector ring 94a, respectively, the electronic clutch 78 operates the motor 22 to output torque at a predetermined maximum value to the spindle 18. In some embodiments, the predetermined maximum value of torque output by the motor 22 may coincide with the maximum rated torque of the motor 22.

[0032] As shown in FIG. 26 and the Table below, the "hammer drill" position of the collar 74a corresponds to a "0 degree" or "first rotational position" position of the collar 74a, in which the recesses R1, R2, R3, R4, R5 of the selector ring 94a are respectively and approximately located at 0, 72, 156, 203 and 300 degrees clockwise from the plane 112, such that the apertures A1, A2, A3, A4, A5 are thereby aligned. When the collar 74a is rotated 36 degrees counterclockwise from the "hammer drill" position to the "drill only" or "second rotational position" as shown in FIG. 27, the recesses R1, R2, R3, R4, R5 are respectively and approximately located at 324 degrees, 36 degrees, 120 degrees, 167 degrees, and 264 degrees clockwise from the plane 112. When the collar 74a is subsequently rotated 36 degrees clockwise from the "drill only" position to the "third rotational position" corresponding to "screwdriver mode" with the first clutch setting as shown in FIG. 28, the recesses R1, R2, R3, R4, R5 are respectively and approximately located at 288 degrees, 0 degrees, 84 degrees, 131 degrees, and 228 degrees clockwise from the plane 112.

[0033] As shown in the Table below and in FIGS. 29-41, the operator may continue to cycle through thirteen additional rotational positions of the collar 74a, each corresponding to a different clutch setting in "screwdriver mode", by incrementally rotating the collar 74a counterclockwise by 18 degrees each time. The first clutch setting (FIG. 28) provides a torque limit that is slightly less than the predetermined maximum value of torque output by the motor 22 available in the "hammer drill" mode or the "drill only" mode. As the clutch setting number numerically increases, the torque threshold applied to the motor 22 decreases, with the fourteenth clutch setting (shown in FIG. 41) providing the lowest torque limit to the motor 22. Unlike the collar 74 of hammer lockout mechanism 90 shown in FIGS. 2-25, the collar 74a of hammer lockout mechanism 90a cannot be rotated a full 360 degrees and beyond in a single rotational direction, clockwise or counter-

EP 3 606 702 B1

clockwise, without any stops which would otherwise limit the extent to which the collar 74a may be rotated. Rather, after reaching the fourteenth clutch setting shown in FIG. 41, the collar 74a may only be rotated back in a clockwise direction as viewed in FIGS. 26-41, cycling chronologically downward through clutch settings thirteen through one in "screwdriver mode" (FIGS. 42-28), then "drill only" (FIG. 27), then "hammer drill" (FIG. 26).

5 **[0034]** As can be seen in FIGS. 26-41, and the Table below, the "hammer drill" position in FIG. 26 is the only position in which all five apertures A1-A5 are aligned with all five recesses R1-R5, thereby disabling the hammer lockout mechanism 90a as described above. In every other setting of the collar 74a and selector ring 94a, no more than two of the apertures A1-A5 are aligned with the recesses R1-R5. Therefore, in "drill-only" mode (FIG. 27) and "screwdriver mode" (FIGS. 28-41, clutch settings 1-14), at least three balls 98a inhibit the rearward movement of the spindle 18, via the first bearing 50, thereby enabling the hammer lockout mechanism 90a and preventing axial reciprocation of the spindle 18 as it rotates.

HAMMER LOCKOUT MECHANISM 90A (FIGS. 26-41)

[0035]

Degrees of collar rotation	A1	A2	A3	A4	A5	Balls in recesses	Mode Setting	Clutch Setting	FIG No.
	Ap erture is alig ned with whic h recess?								
0	R1	R2	R3	R4	R5	5	Hammer Drill	Max Torque	26
36	-	-	R4	-	-	1	Drill Only	Max Torque	27
72	R2	-	-	-	-	1	Screwdriver	1	28
90	-	R3	-	R5	-	2	Screwdriver	2	29
108	-	-	-	R5	-	1	Screwdriver	3	30
126	-	R4	-	-	R2	2	Screwdriver	4	31
144	-	-	R5	-	-	1	Screwdriver	5	32
162	R3	-	-	R1	-	2	Screwdriver	6	33
180	-	-	-	-	-	0	Screwdriver	7	34
198	R4	-	R1	-	-	2	Screwdriver	8	35
216	-	-	-	-	R3	1	Screwdriver	9	36
234	-	-	-	R2	-	2	Screwdriver	10	37
252	-	-	-	-	R4	1	Screwdriver	11	38
270	-	-	R2	-	R4	2	Screwdriver	12	39
288	-	R1	-	-	-	1	Screwdriver	13	40
306	R5	-	-	R3	-	2	Screwdriver	14	41

45 **[0036]** In the hammer lockout mechanism 90a of FIGS. 26-41, besides hammer drill mode, there is never a setting in which two adjacent apertures (e.g., A1 and A2, A3 and A4, A1 and A5) are both aligned with recesses. In other words, when the collar 74a is in the second-sixteenth rotational positions, an aperture that is aligned with a recess is always in between a pair of apertures that are not aligned with recesses. Thus, there are never two adjacent balls 98a permitted to displace radially outwards in response to the spindle 18 contacting a workpiece. In this manner, the load of the balls 98a which prevent rearward displacement of spindle 18 in drill mode and the fourteen settings of screwdriver mode is more evenly distributed around the circumference of the bearing 50, preventing the spindle 18 from tilting and more securely retaining the spindle 18 while it is locked out from hammer mode.

50 **[0037]** In another embodiment of a hammer drill 1010 shown in FIGS. 42-50, the hammer drill 1010 includes a drive mechanism 1014 and a spindle 1018 rotatable in response to receiving torque from the drive mechanism 1014. As shown in FIG. 42, the drive mechanism 1014 includes an electric motor (not shown) and a multi-speed transmission 1026 between the motor and the spindle 1018. The drive mechanism 1014 is at least partially enclosed by a transmission housing 1030. As shown in FIG. 42, a chuck 1034 is provided at the front end of the spindle 1018 so as to be co-rotatable with the spindle 1018. The chuck 1034 includes a plurality of jaws 1038 configured to secure a tool bit or a drill bit (not

shown), such that when the drive mechanism 1014 is operated, the bit can perform a rotary and/or percussive action on a fastener or workpiece. The hammer drill 1010 may be powered by an on-board power source (e.g., a battery, not shown) or a remote power source (e.g., an alternating current source) via a cord (also not shown).

5 [0038] With reference to FIGS. 42 and 44, the hammer drill 1010 includes a first ratchet 1042 coupled for co-rotation with the spindle 1018 and a second ratchet 1046 axially and rotationally fixed to the transmission housing 1030. In some embodiments, the second ratchet 1046 is rotationally fixed to the transmission housing 1030 but allowed to translate axially with respect to the transmission housing 1030. As shown in FIGS. 42, 44, 46 and 48, a first bearing 1050 with an edge 1054 is radially positioned between the transmission housing 1030 and the spindle 1018 and supports a front portion 1058 of the spindle 1018. In the illustrated embodiment, the edge 1054 is concave, but in other embodiments, the edge 1054 may be chamfered or a combination of chamfered and concave. As shown in FIGS. 42, 47 and 49, the front portion of the spindle 1058 includes a radially outward-extending shoulder 1060 adjacent to and axially in front of the bearing 1050, such that the spindle 1018 is not capable of translating axially rearwards unless the bearing 1050 also translates axially rearward. In some embodiments, the bearing 1050 is omitted and the edge 1054 is located on the spindle 1018.

10 [0039] As shown in FIGS. 42, 46 and 48, the second ratchet 1046 includes a bearing pocket 1062 defined in a rear end of the second ratchet 1046. A second bearing 1066 is at least partially positioned in the bearing pocket 1062 and supports a rear portion 1070 of the spindle 1018. In the illustrated embodiment, the second bearing 1066 is wholly received in the bearing pocket 1062, but in other embodiments the second bearing 1066 may at least partially extend from the bearing pocket 1062. By incorporating the bearing pocket 1062 in the second ratchet 1046, the second bearing 1066 is arranged about the rear portion 1070 of the spindle 1018 in a nested relationship within the second ratchet 1046, thereby reducing the overall length of the hammer drill 1010 while also supporting rotation of the spindle 1018. In other embodiments (not shown), the second ratchet 1046 does not include a bearing pocket and the second bearing 1066 is press-fit to the transmission housing 1030.

15 [0040] With reference to FIGS. 42-49, the hammer drill 10 includes a collar 1074 that is rotatably adjustable by an operator of the hammer drill 1010 to shift between "hammer drill," "drill-only," and "screwdriver" modes of operation, and to select a particular clutch setting when in "screwdriver mode." Thus, the collar 1074 is conveniently provided as a single collar 1074 that can be rotated to select different operating modes of the hammer drill 1010 and different clutch settings.

20 [0041] As shown in FIGS. 42 and 43, the hammer drill 1010 includes a mechanical clutch mechanism 1078 capable of limiting the amount of torque that is transferred from the spindle 1018 to a fastener (i.e., when in "screwdriver mode"). The clutch mechanism 1078 includes a plurality of cylindrical pins 1082 received within respective apertures 1086 in the transmission housing 1030, a clutch plate 1090, a clutch face 1098 defined on an outer ring gear 1094 of the transmission 1026, and a plurality of followers, such as balls 1102, positioned between the respective pins 1082 and the clutch face 1098. The outer ring gear 1094 is positioned in the transmission housing 1030 of the drill and is part of the third planetary stage of the transmission 1026. The clutch face 1098 includes a plurality of ramps 1106 over which the balls 1102 ride when the clutch mechanism 1078 is engaged. The ramps 1106 extend an axial distance D1 from the clutch face 1098, such that the balls 1102 must be able to axially translate at least a distance of D1 away from clutch face 1098 in order to ride over the ramps 1106 and thereby clutch the hammer drill 1010. The clutch plate 1090 includes a plurality of first keyways 1110 that are received onto respective keys 1114, which extend radially outward from and axially along an annular portion 1118 of the transmission housing 1030. As such, the clutch plate 1090 is axially movable along the annular portion 1118, but is prevented from rotating with respect to the annular portion 1118.

25 [0042] With continued reference to FIGS. 42 and 43, the clutch mechanism 1078 further includes a retainer 1122 with a first (outer) threaded portion 1126. The first threaded portion 1126 threadably engages a second (inner) threaded portion 1128 on the collar 1074. The clutch mechanism 1078 also includes plurality of biasing members, such as compression springs 1130, that are received in respective seats 1134 on the retainer 1122. Thus, the compression springs 1130 are biased between the retainer 1122 and the clutch plate 1090. A second axial distance D2 coinciding with a gap between the clutch plate 1090 and the retainer 1122, when the hammer drill 1010 is not in operation, is shown in FIG. 42. As will be described in further detail below, the second axial distance D2 is adjustable by rotation of the collar 1074 and corresponding axial adjustment of the retainer 1122. Like the clutch plate 1090, the retainer 1122 includes a plurality of second keyways 1138 that are also received onto the respective keyways 1114. Thus, the retainer 1122 is prevented from rotating with respect to the annular portion 1118 but is allowed to slide axially along the annular portion 1118 as the clutch mechanism 1078 is adjusted by the collar 1074, as will be described in further detail below. In the illustrated embodiment there are six pins 1082, apertures 1086, balls 1102, ramps 1106, and springs 1130. However, other embodiments may include more than six or fewer than six pins, apertures, balls, ramps and springs.

30 [0043] With continued reference to FIGS. 42 and 43, a retaining clip 1142 is locked within a circumferential groove 1146 in the annular portion 1118. The retaining clip 1142 prevents forward axial displacement of a detent ring 1150, which is arranged between a forward portion 1154 of the collar 1074 and the retaining clip 1142. The detent ring 1150 has a plurality of protrusions 1158 that extend radially inward and are designed to fit within gaps 1162 on the annular portion 1118 of the transmission housing, thereby rotationally locking the detent ring 1150 with respect to the annular portion 1118. The detent ring 1150 also has an axially rearward-extending detent portion 1166 that is configured to selectively engage a plurality of

valleys 1170 on the forward portion 1154 of the collar 1074, as will be explained in further detail below.

[0044] With reference to FIGS. 42 and 44-49, the hammer drill 1010 also includes a hammer lockout mechanism 1174 for selectively inhibiting the first and second ratchets 1042, 1046 from engaging when the hammer drill 1010 is in a "screwdriver mode" or a "drill-only mode." The hammer lockout mechanism 1174 includes a lockout ring 1178 coupled for co-rotation with and positioned inside the collar 1074, and a plurality of detents, such as balls B1, B2, B3, B4 and B5 situated within corresponding radial apertures A1, A2, A3, A4, and A5 asymmetrically positioned around the annular portion 1118 of the transmission housing 1030. As shown in FIGS. 44, 45, 46 and 48, the lockout ring 1178 includes a plurality of recesses R1, R2, R3, R4, and R5 asymmetrically positioned about an inner surface 1182 of the lockout ring 1178. The number of recesses R1-R5 corresponds to the number of apertures A1-A5 and the number of balls B1-B5 within the respective apertures A1-A5.

[0045] In the illustrated embodiment, five apertures A1-A5 containing five balls B1-B5 are located in the annular portion 1118 of the transmission housing 1030 and five recesses R1-R5 are defined in the lockout ring 1178. However, in other embodiments, the hammer lockout mechanism 1174 could employ more or fewer apertures, balls, and recesses. As shown in FIGS. 46 and 48, the five apertures A1-A5 are approximately located at 0 degrees, 55 degrees, 145 degrees, 221 degrees, and 305 degrees, respectively, measured in a counterclockwise direction from an oblique plane 1186 containing a longitudinal axis 1190 of the hammer drill 1010 and bisecting aperture A1.

[0046] As shown in FIGS. 42, 44, 47 and 49, the first ratchet 1042 and the first bearing 1050 are set within a cylindrical cavity 1194 defined within the annular portion 1118 of the transmission housing 1030, and the lockout ring 1178 is radially arranged between the annular portion 1118 and the collar 1074, surrounding the apertures A1-A5. As shown in FIGS. 42 and 44, a lockout spring 1196 is also arranged within the cavity 1194 between the second ratchet 1046 and the first bearing 1050. The lockout spring 1196 biases the first bearing 1050 away from the second ratchet 1046. As shown in FIG. 45, a rear rim 1198 of the collar 1074 includes a first stop 1202 that extends radially inward. The first stop 1202 is configured to abut against a second stop 1206 on the transmission housing 1030, as shown in FIG. 50 and as will be explained in further detail below.

[0047] In operation, as shown in FIGS. 46 and 47, when the collar 1074 and lockout ring 1178 are rotated together to a position corresponding to a "hammer drill" mode, all five apertures A1-A5 are aligned with all five recesses R1-R5 in the lockout ring 1178, respectively. Therefore, when the bit held by the jaws 1038 contacts a workpiece, the normal force of the workpiece pushes the bit axially rearward, i.e., away from the workpiece. The axial force experienced by the tool bit is applied through the spindle 1018 in a rearward direction, causing the spindle 1018 to move axially rearward, thus forcing the first bearing 1050 to move rearward and the edge 1054 of the first bearing 1050 to displace each of the balls B1-B5 situated in the respective apertures A1-A5 radially outward to a "unlocking position", in which the balls B1-B5 are respectively partially received into the recesses R1-R5, thereby disabling the hammer lockout mechanism 1174. Thus, the first ratchet 1042 is permitted to engage with the second ratchet 1046 to impart reciprocation to the spindle 1018 as it rotates.

[0048] However, when the collar 1074 and lockout ring 1178 are incrementally rotated (e.g., by 18 degrees) in a counterclockwise direction to a second rotational position shown in FIGS. 48 and 49, none of the apertures A1-A5 are aligned with the recesses R1-R5. Thus, in this position of the collar 1074 and lockout ring 1178, the balls B1-B5 in the respective apertures A1-A5 are prevented from being radially displaced into the recesses R1-R5 in response to the tool bit contacting a workpiece and the spindle 1018 and first bearing 1050 attempting to move axially rearward. Rather, the edge 1054 of the first bearing 1050 presses against the balls B1-B5, which in turn abut against the inner surface 1182 of the lockout ring 1178 and are inhibited from displacing radially outward. In other words, the balls B1-B5 remain in "locking positions" and each ball is prevented from moving from the locking position to the unlocking position. Thus, the spindle 1018 is blocked by the balls B1-B5 in their locking positions, via the first bearing 1050, and therefore the spindle 1018 is prevented from moving rearward, maintaining a gap 1210 between the first and second ratchets 1042, 1046. Thus, in the second rotational position of the collar 1074 and the lockout ring 1178, the hammer lockout mechanism 1174 is enabled, preventing the spindle 1018 from reciprocating in an axial manner as it is rotated by the drive mechanism 1014, operating the hammer drill 1010 in a "drill only" mode.

[0049] There are a total of twenty different positions between which the collar 1074 and lockout ring 1178 can rotate, such that the collar 1074 is rotated 18 degrees between each of the positions. As the collar 1074 is rotated, the retainer 1122 axially adjusts along the annular portion 1118 via the threaded engagement between the first threaded portion 1126 of the retainer 1122 and the second threaded portion 1128 of the collar 1074. Thus, depending on which position the collar 1074 has been rotated to, the axial adjustment of the retainer 1122 adjusts the pre-load on the springs 1130, thereby increasing or decreasing the torque limit of the clutch mechanism 1078. Further, as the retainer 1122 is adjusted axially away from the clutch plate 1090, the second axial distance D2 is increased, and as the retainer 1122 is adjusted axially towards the clutch plate 1090, the second axial distance D2 is decreased. For each position the collar 1074 is rotated to, the detent portion 1166 engages one of the valleys 1170 on the forward portion 1154 of the collar 1074, thereby temporarily locking the collar 1074 in the respective rotational position.

[0050] As shown in FIG. 46 and the Table below, the "hammer drill" position of the collar 1074 corresponds to a "0

degree" or "first rotational position" position of the collar 1074, in which the recesses R1, R2, R3, R4, R5 of the lockout ring 1178 are respectively and approximately located at 0, 55, 145, 221, and 305 degrees counterclockwise from the plane 1186, such that the apertures A1, A2, A3, A4, A5 are thereby aligned. When the collar 1074 is rotated 18 degrees counterclockwise from the "hammer drill" position to the "drill only" or "second rotational position" as shown in FIG. 48, the recesses R1, R2, R3, R4, R5 are respectively and approximately located at 18 degrees, 73 degrees, 163 degrees, 239 degrees, and 323 degrees counterclockwise from the plane 1186.

[0051] As shown in FIGS. 46 and 47, in the "hammer drill" mode coinciding with the first rotational position of the collar 1074 and lockout ring 1178, respectively, the retainer 1122 is adjusted to a first axial position with respect to the transmission housing 1030. The first axial position of the retainer 1122 corresponds to a minimum value of the second axial distance D2, in which D2 is less than the first axial distance D1. In operation during "hammer drill" mode, the clutch plate 1090 is capable of being axially translated by balls 1102 and pins 1082 towards the retainer 1122 by a maximum axial distance of D2. Thus, balls 1102 are capable of axially translating a maximum distance of D2 away from clutch face 1098, but because D2 is less than D1, the balls 1102 are prevented from riding over ramps 1106, which have an axial length of D1. Thus, in "hammer drill" mode, the clutch mechanism 1078 is locked out and the motor is permitted to output torque at a maximum value to the spindle 1018. In some embodiments, the maximum value of torque output by the motor may coincide with the maximum rated torque of the motor.

[0052] As shown in FIGS. 48 and 49, in the "drill only" mode coinciding with the second rotational position of the collar 1074 and lockout ring 1178, the retainer 1122 is axially adjusted to a second axial position that is a slight axial distance away from the first axial position and the transmission housing 1030, such that there is a slight increase in the second axial distance D2 and thus a slight decrease in the preload on the springs 1130. However, in the second axial position the second axial distance D2 is still less than the first axial distance D1. Thus, the clutch mechanism 1078 is still locked-out in "drill only" mode, allowing the motor to output torque at a maximum value to the spindle 1018.

[0053] As shown in the Table below, the operator may continue to cycle through eighteen additional rotational positions of the collar 1074, each corresponding to a different clutch setting in "screwdriver mode", by incrementally rotating the collar 1074 counterclockwise by 18 degrees each time. As the clutch setting number numerically increases, the retainer 1122 moves progressively axially farther away from the first axial position, causing the pre-load on the springs 1130, and thus the torque limit of the clutch mechanism 1078, to progressively decrease, with the eighteenth clutch setting providing the lowest torque limit to the motor. In all eighteen clutch settings of "screwdriver mode", the retainer 1122 is axially far enough away from the first axial position that the second axial distance D2 is greater than the first axial distance D1. Thus, in all eighteen clutch settings of "screwdriver mode", the clutch mechanism 1078 reduces the torque output of the spindle 1018, as described below.

[0054] In operation of "screwdriver mode", torque is transferred from the electric motor, through the transmission 1026, and to the spindle 1018, during which time the outer ring gear 1094 remains stationary with respect to the transmission housing 1030 due to the pre-load exerted on the clutch face 1098 by the springs 1130, the clutch plate 1090, the pins 1082 and the balls 1102. Upon continued tightening of the fastener to a particular torque, a corresponding reaction torque is imparted to the spindle 1018, causing the rotational speed of the spindle 1018 to decrease. When the reaction torque exceeds the torque limit set by the collar 1074 and retainer 1122, the motor torque is transferred to the outer ring gear 1094, causing it to rotate with respect to the transmission housing 1030, thereby engaging the clutch mechanism 1078 and diverting the motor torque from the spindle 1018. As a result, and because the second axial distance D2 is greater than first axial distance D1, the balls 1102 are permitted to axially translate far enough away from clutch face 1098 that the balls 1102 are allowed them to ride up and down the ramps 1106 on the clutch face 1098, causing the clutch plate 1090 to reciprocate along the transmission housing 1030 against the bias of the springs 1130.

[0055] As can be seen in FIG. 46 and the Table below, the "hammer drill" position in FIG. 46 is the only position in which all five apertures A1-A5 are aligned with all five recesses R1-R5, thereby disabling the hammer lockout mechanism 1090 as described above. In every other setting of the collar 1074 and lockout ring 1178, no more than two of any of the apertures A1-A5 are aligned with the recesses R1-R5. Therefore, in "drill-only" mode (FIG. 48) and "screwdriver mode" (clutch settings 1-18), at least three of the balls B1-B5 inhibit the rearward movement of the spindle 1018, via the first bearing 1050, thereby enabling the hammer lockout mechanism 1090 and preventing axial reciprocation of the spindle 1018 as it rotates.

HAMMER LOCKOUT MECHANISM 1090 (FIGS. 42-50)

[0056]

EP 3 606 702 B1

Degrees of collar rotation	A1	A2	A3	A4	A5	Balls in recesses	Mode Setting	Clutch Setting	FIG No.
Aperture is aligned with which recess?									
0	R1	R2	R3	R4	R5	5	Hammer Drill	Max Torque	46
18	-	-	-	-	-	0	Drill Only	Max Torque	48
36	-	-	-	-	-	0	Screwdriver	1	N/A
54	R5	R1	-	-	-	2	Screwdriver	2	N/A
72	-	-	-	R3	R4	2	Screwdriver	3	N/A
90	-	-	R2	-	R4	2	Screwdriver	4	N/A
108	-	R5	-	-	-	1	Screwdriver	5	N/A
126	-	-	-	-	-	0	Screwdriver	6	N/A
144	R4	-	R1	-	-	2	Screwdriver	7	N/A
162	-	-	-	R2	R3	2	Screwdriver	8	N/A
180	-	-	-	-	-	0	Screwdriver	9	N/A
198	-	R4	R5	-	-	2	Screwdriver	10	N/A
216	R3	-	-	R1	-	2	Screwdriver	11	N/A
234	-	-	-	-	-	0	Screwdriver	12	N/A
252	-	-	-	-	R2	1	Screwdriver	13	N/A
270	-	R3	-	R5	-	2	Screwdriver	14	N/A
288	-	-	R4	R5	-	2	Screwdriver	15	N/A
306	R2	-	-	-	R1	2	Screwdriver	16	N/A
324	-	-	-	-	-	0	Screwdriver	17	N/A
342	-	-	-	-	-	0	Screwdriver	18	N/A

[0057] In some embodiments, the hammer drill 1010 is adjustable between "hammer drill" mode, "drill only" mode and the eighteen clutch settings of "screwdriver" mode by rotating the collar 342 degrees, but the collar is prevented from rotating a full 360 degrees because the first stop 1202 of the collar (FIG. 45) physically abuts the second stop 1206 on the transmission housing 1030 (FIG. 50). Thus, when an operator is using the hammer drill 1010 in the eighteenth clutch setting of "screwdriver" mode, but desires to set the hammer drill 1010 back to "hammer drill" mode, the operator must rotate the collar 1074 in an opposite (clockwise) direction back through clutch settings 17 to 1 and "drill only" mode before arriving at the first rotational position, which corresponds to the "hammer drill" setting (FIG. 47).

[0058] However, in other embodiments, the first and second stops 1202, 1206 are omitted, and the collar 1074 may be rotated a full 360 degrees and beyond in a single rotational direction, clockwise or counterclockwise, without any stops which would otherwise limit the extent to which the collar 1074 may be rotated. Therefore, if the operator is using the hammer drill 1010 in "screwdriver mode" on the eighteenth clutch setting, the operator needs only to rotate the collar 1074 counterclockwise by an additional 18 degrees to switch the hammer drill 1010 into "hammer drill" mode, rather than rotating the collar 1074 in an opposite (clockwise) direction back through clutch settings 17 to 1 and "drill only" mode.

[0059] Various features of the invention are set forth in the following claims.

Claims

1. A hammer drill (10, 1010) comprising:

a drive mechanism (14, 1014) including an electric motor (22) and a transmission (26, 1026);
 a housing (30, 1030) enclosing at least a portion of the drive mechanism;
 a spindle (18, 1018) rotatable in response to receiving torque from the drive mechanism;
 a first ratchet (42, 1042) coupled for co-rotation with the spindle;
 5 a second ratchet (46, 1046) rotationally fixed to the housing;
 a hammer lockout mechanism (90, 90a, 1174) adjustable between a first mode and a second mode, the hammer
 lockout mechanism including a detent movable between a locking position and an unlocking position;
 a clutch (78, 1078) adjustable between a first state in which a torque output of the spindle is a predetermined
 10 maximum value, and a second state in which torque output of the spindle is limited to a value less than the
 predetermined maximum value; and
 a collar (74, 1074) rotatably coupled to the housing, **characterised in that** the collar (74, 1074) is movable
 between a first rotational position in which the hammer lockout mechanism is in the first mode and the clutch is in
 the first state, a second rotational position in which the hammer lockout mechanism is in the second mode and the
 15 clutch is in the first state, and a third rotational position in which the hammer lockout mechanism is in the second
 mode and the clutch is in the second state,
 wherein in the first mode the detent is moveable from the locking position to the unlocking position, such that the
 spindle is movable relative to the housing in response to contact with a workpiece, causing the first and second
 ratchets to engage, and
 wherein in the second mode the detent is prevented from moving from the locking position to the unlocking
 20 position, such that the spindle is blocked by the detent from moving relative to the housing in response to contact
 with a workpiece and a gap is maintained between the first and second ratchets.

2. The hammer drill (10, 1010) of claim 1, wherein the hammer lockout mechanism (90, 90a, 1174) includes an aperture
 (A1, A2, A3, A4, A5) in the housing and the detent is a ball (98, 98a, 1102, B1, B2, B3, B4, B5) arranged in the aperture,
 25 and wherein the ball is moveable within the aperture between the locking position and the unlocking position.
3. The hammer drill (10, 1010) of claim 2, wherein the collar (74, 1074) includes a recess (R1, R2, R3, R4, R5), and
 wherein when the collar is in the first rotational position, the aperture is aligned with the recess, and wherein when the
 collar is in the second and third rotational positions, the aperture is not aligned with the recess, and wherein the ball is at
 30 least partially received in the recess when the ball is in the unlocking position.
4. The hammer drill (10, 1010) of claim 2, wherein the hammer lockout mechanism includes a first bearing (50, 1050)
 rotatably supporting the spindle (18, 1018), and wherein when the collar (74, 1074) is in the second and third rotational
 35 positions, the ball in the locking position prevents the first bearing from moving relative to the housing in response to an
 axial force applied to the spindle in a rearward direction.
5. The hammer drill (10, 1010) of claim 4, wherein the second ratchet (46, 1046) includes a pocket (62, 1062), and
 wherein a second bearing (66, 1066) that rotatably supports the spindle is at least partially positioned in the pocket.
- 40 6. The hammer drill (10, 1010) of claim 4, wherein the first bearing includes an edge (54, 1054) that contacts the ball when
 the ball is in the locking position and the axial force is applied to the spindle in the rearward direction.
7. The hammer drill (10, 1010) of claim 6, wherein when the collar is in the first rotational position and the axial force is
 applied to the spindle in the rearward direction, the ball is moved along the edge from the locking position to the
 45 unlocking position,
 and optionally, wherein the edge has a shape selected from the group consisting of concave, chamfered, and a
 combination of concave and chamfered.
8. The hammer drill (10, 1010) of claim 1, wherein the second ratchet (46, 1046) is axially fixed with respect to the housing
 50 (30, 1030).
9. The hammer drill (10, 1010) of claim 1, wherein the second ratchet includes a pocket (62, 1062), and wherein a bearing
 (50, 1050) that rotatably supports the spindle is at least partially positioned in the pocket.
- 55 10. The hammer drill (10, 1010) of claim 1, wherein the clutch (78, 1078) is an electronic clutch,
 and optionally:

(i) wherein the electronic clutch comprises:

a printed circuit board (82) having a plurality of electronic pads (86) corresponding to different values of the torque output of the electric motor (22); and
 a wiper coupled for co-rotation with the collar (74, 1074),
 wherein the wiper is in electrical contact with the pads as the collar rotates relative to the printed circuit board;
 or

(ii) wherein the electronic clutch includes one or more of a potentiometer, a Halleffect sensor, and an inductive sensor.

11. The hammer drill (10, 1010) of claim 1, wherein the clutch (78, 1078) is a mechanical clutch.

12. The hammer drill (10, 1010) of claim 11, wherein the transmission (26, 1026) is a multi-stage planetary transmission having a ring gear (1094), wherein the mechanical clutch includes a clutch face (1098) defined in the ring gear and a plurality of followers (1102) engaged with the clutch face, wherein in the first state, the followers are biased against the clutch face at a first preload value, and wherein in the second state, the followers are biased against the clutch face at a second preload value,
 and optionally, wherein the mechanical clutch includes a retainer (1122) in which a plurality of springs (1130) are received, each one of the springs respectively biasing one of the followers against the clutch face, and wherein movement of the collar (74, 1074) from the first rotational position to the second rotational position moves the retainer from a first axial position to a second axial position, and wherein movement of the collar from the second rotational position to the third rotational position moves the retainer from the second axial position to a third axial position, and further optionally:

(i) wherein the retainer includes a first threaded portion (1126) that is threadably engaged within a second threaded portion (1128) of the collar; or

(ii) wherein the clutch face includes a plurality of ramps (1106) extending a first distance from the clutch face, and wherein the mechanical clutch includes a clutch plate (1090) between the springs and the followers, and further optionally:

(a) wherein an adjustable gap is defined between the clutch plate and the retainer, the adjustable gap defining a second distance, and wherein movement of the retainer from the first axial position to the second axial position increases the second distance of the adjustable gap,

and further optionally, wherein when the second distance is greater than the first distance, the clutch reduces a torque output of the spindle, and wherein when the second distance is less than the first distance, the clutch is locked out, thereby transferring a maximum torque developed by the motor to the spindle (18, 1018), and further optionally, wherein when the collar is in the first rotational position, the second distance is less than the first distance; or

(b) wherein the mechanical clutch includes a plurality of pins (1082), with one pin arranged between each follower and the clutch plate.

13. A hammer drill (10, 1010) comprising:

a drive mechanism (14, 1014) including an electric motor (22) and a transmission (26, 1026);
 a housing (30, 1030) enclosing at least a portion of the drive mechanism;
 a spindle (18, 1018) arranged in the housing and rotatable in response to receiving torque from the drive mechanism;
 a first ratchet (42, 1042) arranged in the housing and coupled for co-rotation with the spindle;
 a second ratchet (46, 1046) rotationally fixed to the housing;
 a hammer lockout mechanism (90, 90a, 1174) including a plurality of apertures (A1, A2, A3, A4, A5) in the housing and a ball (98, 98a, 1102, B1, B2, B3, B4, B5) arranged in each of the apertures;
 a clutch (78, 1078) adjustable between a first state in which a torque output of the spindle is a predetermined maximum value, and a second state in which torque output of the spindle is limited to a value less than the predetermined maximum value; and
 a collar (74, 1074) rotatably coupled to the housing and including a plurality of recesses (R1, R2, R3, R4, R5), **characterised in that** the collar is moveable between a first rotational position, in which each of the recesses is aligned with one of the apertures and the clutch is in the first state, a second rotational position, in which at least one recess is not aligned with any of the apertures and the clutch is in the first state, and a third rotational position, in which at least one recess is not aligned with any of the apertures and the clutch is in the second state,

wherein each of the balls is moveable within its respective aperture between an unlocking position, in which the ball is at least partially received in one of the recesses of the collar, and a locking position, in which the ball is not received in any of the recesses of the collar,

wherein when the collar is in the first rotational position, the balls are each moveable from the locking position to the unlocking position, such that the spindle is movable relative to the housing in response to an axial force applied to the spindle in a rearward direction, allowing the first and second ratchets to engage, and

wherein when the collar is in the second and third rotational positions, at least one ball is prevented from moving from the locking position to the unlocking position, such that the at least one ball in the locking position blocks the spindle from moving relative to the housing in response to the axial force applied to the spindle in the rearward direction and a gap is maintained between the first and second ratchets.

14. The hammer drill (10, 1010) of claim 13,

wherein when the collar (74, 1074) is in the second and third rotational positions, at least three recesses (R1, R2, R3, R4, R5) are not aligned with any of the apertures (A1, A2, A3, A4, A5), such that at least three balls (98, 98a, 1102, B1, B2, B3, B4, B5) are prevented from moving from the locking position to the unlocking position, or wherein when the collar is in the second and third rotational positions and at least one of plurality of apertures is aligned with one of the plurality of recesses, each aperture that is aligned with one of the recesses is between two apertures that are not aligned with any of the recesses.

15. The hammer drill (10, 1010) of claim 13, further comprising a bearing (50, 1050) rotatably supporting the spindle (18, 1018), and wherein when the collar (74, 1074) is in the second and third rotational positions, the at least one ball (98, 98a, 1102, B1, B2, B3, B4, B5) in the locking position prevents the bearing from moving relative to the housing in response to the axial force applied to the spindle in the rearward direction, and optionally, wherein the bearing includes an edge (54, 1054), and wherein when the collar is in the first rotational position and the axial force is applied to the spindle (18, 1018) in the rearward direction, each of the plurality of balls is moved along the edge from the locking position to the unlocking position.

Patentansprüche

1. Hammerbohrer (10, 1010), umfassend:

einen Antriebsmechanismus (14, 1014), der einen Elektromotor (22) und ein Getriebe (26, 1026) einschließt;
 ein Gehäuse (30, 1030), das mindestens einen Abschnitt des Antriebsmechanismus umschließt;
 eine Spindel (18, 1018), die drehbar ist, wenn sie ein Drehmoment von dem Antriebsmechanismus empfängt;
 eine erste Sperrklinke (42, 1042), die drehfest mit der Spindel verbunden ist;
 eine zweite Sperrklinke (46, 1046), die drehbar am Gehäuse befestigt ist;
 einen Hammerverriegelungsmechanismus (90, 90a, 1174), der zwischen einem ersten Modus und einem zweiten Modus einstellbar ist, wobei der Hammerverriegelungsmechanismus eine zwischen einer Verriegelungsposition und einer Entriegelungsposition bewegliche Arretierung einschließt;
 eine Kupplung (78, 1078), die zwischen einem ersten Zustand, in dem ein Ausgangsdrehmoment der Spindel ein vorbestimmter Maximalwert ist, und einem zweiten Zustand, in dem das Ausgangsdrehmoment der Spindel auf einen Wert kleiner als der vorbestimmte Maximalwert begrenzt ist, einstellbar ist; und
 einen Kragen (74, 1074), der drehbar mit dem Gehäuse gekoppelt ist, **dadurch gekennzeichnet, dass** der Kragen (74, 1074) zwischen einer ersten Drehposition, in der sich der Hammerverriegelungsmechanismus in der ersten Betriebsart und die Kupplung im ersten Zustand befindet, einer zweiten Drehposition, in der sich der Hammerverriegelungsmechanismus in der zweiten Betriebsart und die Kupplung im ersten Zustand befindet, und einer dritten Drehposition, in der sich der Hammerverriegelungsmechanismus in der zweiten Betriebsart und die Kupplung im zweiten Zustand befindet, beweglich ist,
 wobei in dem ersten Modus die Arretierung von der Verriegelungsposition in die Entriegelungsposition bewegbar ist, sodass die Spindel als Reaktion auf den Kontakt mit einem Werkstück relativ zu dem Gehäuse bewegbar ist, wodurch die erste und die zweite Klinke in Eingriff gebracht werden, und
 wobei in dem zweiten Modus die Arretierung daran gehindert wird, sich von der Verriegelungsposition in die Entriegelungsposition zu bewegen, sodass die Spindel durch die Arretierung daran gehindert wird, sich als Reaktion auf den Kontakt mit einem Werkstück relativ zum Gehäuse zu bewegen, und ein Spalt zwischen der ersten und der zweiten Sperrklinke aufrechterhalten wird.

2. Hammerbohrer (10, 1010) nach Anspruch 1, wobei der Hammerverriegelungsmechanismus (90, 90a, 1174) eine Blende (A1, A2, A3, A4, A5) in dem Gehäuse einschließt und die Arretierung eine Kugel (98, 98a, 1102, B1, B2, B3, B4, B5) ist, die in der Blende angeordnet ist, und wobei die Kugel innerhalb der Blende zwischen der Verriegelungsposition und der Entriegelungsposition bewegbar ist.
- 5
3. Hammerbohrer (10, 1010) nach Anspruch 2, wobei der Kragen (74, 1074) eine Vertiefung (R1, R2, R3, R4, R5) einschließt, und wobei, wenn sich der Kragen in der ersten Drehposition befindet, die Blende mit der Vertiefung ausgerichtet ist, und wobei, wenn sich der Kragen in der zweiten und dritten Drehposition befindet, die Blende nicht mit der Vertiefung ausgerichtet ist, und wobei die Kugel mindestens teilweise in der Vertiefung empfangen wird, wenn sich die Kugel in der Entriegelungsposition befindet.
- 10
4. Hammerbohrer (10, 1010) nach Anspruch 2, wobei der Hammerverriegelungsmechanismus ein erstes Lager (50, 1050) einschließt, das die Spindel (18, 1018) drehbar abstützt, und wobei, wenn sich der Kragen (74, 1074) in der zweiten und dritten Drehposition befindet, die Kugel in der Verriegelungsposition das erste Lager daran hindert, sich als Reaktion auf eine axiale Kraft, die auf die Spindel in einer Rückwärtsrichtung ausgeübt wird, relativ zum Gehäuse zu bewegen.
- 15
5. Hammerbohrer (10, 1010) nach Anspruch 4, wobei die zweite Sperrklinke (46, 1046) eine Tasche (62, 1062) einschließt, und wobei ein zweites Lager (66, 1066), das die Spindel drehbar abstützt, mindestens teilweise in der Tasche positioniert ist.
- 20
6. Hammerbohrer (10, 1010) nach Anspruch 4, wobei das erste Lager einen Rand (54, 1054) einschließt, der die Kugel berührt, wenn sich die Kugel in der Verriegelungsposition befindet und die Axialkraft in rückwärtiger Richtung auf die Spindel ausgeübt wird.
- 25
7. Hammerbohrer (10, 1010) nach Anspruch 6, wobei, wenn sich der Bund in der ersten Drehposition befindet und die Axialkraft in Rückwärtsrichtung auf die Spindel ausgeübt wird, die Kugel entlang des Randes von der Verriegelungsposition in die Entriegelungsposition bewegt wird, und optional, wobei der Rand eine Form aufweist, die aus der Gruppe ausgewählt ist, bestehend aus konkav, abgeschrägt und einer Kombination aus konkav und abgeschrägt.
- 30
8. Hammerbohrer (10, 1010) nach Anspruch 1, wobei die zweite Sperrklinke (46, 1046) in Bezug auf das Gehäuse (30, 1030) axial fixiert ist.
- 35
9. Hammerbohrer (10, 1010) nach Anspruch 1, wobei die zweite Sperrklinke eine Tasche (62, 1062) einschließt, und wobei ein Lager (50, 1050), das die Spindel drehbar abstützt, mindestens teilweise in der Tasche positioniert ist.
- 40
10. Hammerbohrer (10, 1010) nach Anspruch 1, wobei die Kupplung (78, 1078) eine elektronische Kupplung ist, und optional:
- (i) wobei die elektronische Kupplung Folgendes umfasst:
- eine gedruckte Schaltungsplatte (82), die eine Vielzahl von elektronischen Pads (86) aufweist, die verschiedenen Werten der Drehmomentabgabe des Elektromotors (22) entsprechen; und
- 45 einen Wischer, der mit dem Kragen (74, 1074) drehbar verbunden ist, wobei der Wischer in elektrischem Kontakt mit den Pads steht, wenn sich der Kragen relativ zur gedruckten Schaltungsplatte dreht; oder
- (ii) wobei die elektronische Kupplung eines oder mehrere von einem Potentiometer, einem Hall-Effekt-Sensor und einem induktiven Sensor einschließt.
- 50
11. Hammerbohrer (10, 1010) nach Anspruch 1, wobei die Kupplung (78, 1078) eine mechanische Kupplung ist.
12. Hammerbohrer (10, 1010) nach Anspruch 11, wobei das Getriebe (26, 1026) ein mehrstufiges Planetengetriebe mit einem Hohlrad (1094) ist, wobei die mechanische Kupplung eine in dem Hohlrad definierte Kupplungsfläche (1098) und eine Vielzahl von Mitnehmern (1102) aufweist, die mit der Kupplungsfläche in Eingriff stehen, wobei in dem ersten Zustand die Mitnehmer mit einem ersten Vorspannungswert gegen die Kupplungsfläche vorgespannt sind, und wobei in dem zweiten Zustand die Mitnehmer mit einem zweiten Vorspannungswert gegen die Kupplungsfläche vorge-
- 55

spannt sind,

und optional, wobei die mechanische Kupplung einen Halter (1122) einschließt, in dem eine Vielzahl von Federn (1130) empfangen wird, wobei jede der Federn jeweils einen der Mitnehmer gegen die Kupplungsfläche vorspannt, und wobei die Bewegung des Kragens (74, 1074) von der ersten Drehposition in die zweite Drehposition den Halter von einer ersten axialen Position in eine zweite axiale Position bewegt, und wobei die Bewegung des Kragens von der zweiten Drehposition in die dritte Drehposition den Halter von der zweiten axialen Position in eine dritte axiale Position bewegt, und ferner optional:

- (i) wobei der Halter einen ersten Gewindeabschnitt (1126) einschließt, der in einen zweiten Gewindeabschnitt (1128) des Kragens eingeschraubt ist; oder
- (ii) wobei die Kupplungsfläche eine Vielzahl von Rampen (1106) einschließt, die sich in einem ersten Abstand von der Kupplungsfläche erstrecken, und wobei die mechanische Kupplung eine Kupplungsscheibe (1090) zwischen den Federn und den Mitnehmern einschließt,

und ferner optional:

- (a) wobei ein einstellbarer Spalt zwischen der Kupplungsscheibe und dem Halter definiert ist, wobei der einstellbare Spalt einen zweiten Abstand definiert, und wobei die Bewegung des Halters von der ersten axialen Position zur zweiten axialen Position den zweiten Abstand des einstellbaren Spalts steigert,

und ferner optional, wobei, wenn der zweite Abstand größer als der erste Abstand ist, die Kupplung ein Ausgangsdrehmoment der Spindel reduziert, und wobei, wenn der zweite Abstand kleiner als der erste Abstand ist, die Kupplung gesperrt wird, wodurch ein vom Motor entwickeltes maximales Drehmoment auf die Spindel (18, 1018) übertragen wird, und ferner optional, wobei, wenn sich der Kragen in der ersten Drehposition befindet, der zweite Abstand geringer ist als der erste Abstand; oder

- (b) wobei die mechanische Kupplung eine Vielzahl von Stiften (1082) einschließt, wobei ein Stift zwischen jedem Mitnehmer und der Kupplungsscheibe angeordnet ist.

13. Hammerbohrer (10, 1010), umfassend:

einen Antriebsmechanismus (14, 1014), der einen Elektromotor (22) und ein Getriebe (26, 1026) einschließt; ein Gehäuse (30, 1030), das mindestens einen Abschnitt des Antriebsmechanismus umschließt; eine Spindel (18, 1018), die in dem Gehäuse angeordnet und drehbar ist, wenn sie ein Drehmoment von dem Antriebsmechanismus empfängt; eine erste Sperrklinke (42, 1042), die in dem Gehäuse angeordnet und mit der Spindel drehbar gekoppelt ist; eine zweite Sperrklinke (46, 1046), die drehbar am Gehäuse befestigt ist; einen Hammerverriegelungsmechanismus (90, 90a, 1174), der eine Vielzahl von Blenden (A1, A2, A3, A4, A5) in dem Gehäuse und eine in jeder der Blenden angeordnete Kugel (98, 98a, 1102, B1, B2, B3, B4, B5) einschließt; eine Kupplung (78, 1078), die zwischen einem ersten Zustand, in dem ein Ausgangsdrehmoment der Spindel ein vorbestimmter Maximalwert ist, und einem zweiten Zustand, in dem das Ausgangsdrehmoment der Spindel auf einen Wert kleiner als der vorbestimmte Maximalwert begrenzt ist, einstellbar ist; und einen Kragen (74, 1074), der drehbar mit dem Gehäuse gekoppelt ist und eine Vielzahl von Vertiefungen (R1, R2, R3, R4, R5) einschließt,

dadurch gekennzeichnet, dass der Kragen zwischen einer ersten Drehposition beweglich ist, in der jede der Vertiefungen mit einer der Blenden ausgerichtet ist und die Kupplung sich im ersten Zustand befindet, einer zweiten Drehposition, in der mindestens eine Vertiefung nicht mit einer der Blenden ausgerichtet ist und die Kupplung sich im ersten Zustand befindet, und eine dritte Drehposition, in der mindestens eine Vertiefung nicht mit einer der Blenden ausgerichtet ist und die Kupplung sich im zweiten Zustand befindet,

wobei jede der Kugeln innerhalb ihrer jeweiligen Blende zwischen einer Entriegelungsposition, in der die Kugel zumindest teilweise in einer der Vertiefungen des Kragens empfangen wird, und einer Verriegelungsposition, in der die Kugel in keiner der Vertiefungen des Kragens empfangen wird, beweglich ist, wobei, wenn sich der Kragen in der ersten Drehposition befindet, die Kugeln jeweils aus der Verriegelungs-

position in die Entriegelungsposition bewegt werden können, so dass die Spindel als Reaktion auf eine axiale Kraft, die auf die Spindel in einer rückwärtigen Richtung ausgeübt wird, relativ zum Gehäuse bewegt werden kann, so dass die erste und die zweite Sperrklinke ineinander greifen können, und wobei, wenn sich die Sperrklinke in der zweiten und dritten Drehposition befindet, mindestens eine Kugel daran gehindert wird, sich von der Verriegelungsposition in die Entriegelungsposition zu bewegen, so dass die mindestens eine Kugel in der Verriegelungsposition die Spindel daran hindert, sich als Reaktion auf die auf die Spindel in der Rückwärtsrichtung ausgeübte Axialkraft relativ zum Gehäuse zu bewegen, und ein Spalt zwischen der ersten und der zweiten Sperrklinke aufrechterhalten wird.

14. Hammerbohrer (10, 1010) nach Anspruch 13, wobei, wenn sich der Kragen (74, 1074) in der zweiten und dritten Drehstellung befindet, mindestens drei Vertiefungen (R1, R2, R3, R4, R5) nicht mit einer der Blenden (A1, A2, A3, A4, A5) ausgerichtet sind, sodass mindestens drei Kugeln (98, 98a, 1102, B1, B2, B3, B4, B5) daran gehindert werden, von der Verriegelungsstellung in die Entriegelungsstellung zu gelangen, oder wobei, wenn sich der Kragen in der zweiten und dritten Drehstellung befindet und mindestens eine der Vielzahl von Blenden mit einer der Vielzahl von Vertiefungen ausgerichtet ist, jede Blende, die mit einer der Vertiefungen ausgerichtet ist, zwischen zwei Blenden liegt, die nicht mit einer der Vertiefungen ausgerichtet sind.
15. Hammerbohrer (10, 1010) nach Anspruch 13, ferner umfassend ein Lager (50, 1050), das die Spindel (18, 1018) drehbar abstützt, wobei die mindestens eine Kugel (98, 98a, 1102, B1, B2, B3, B4, B5) in der Verriegelungsposition, wenn sich der Kragen (74, 1074) in der zweiten und dritten Drehposition befindet, verhindert, dass sich das Lager als Reaktion auf die auf die Spindel in Rückwärtsrichtung ausgeübte Axialkraft relativ zum Gehäuse bewegt, und optional, wobei das Lager einen Rand (54, 1054) einschließt, und wobei, wenn sich der Rand in der ersten Drehposition befindet und die Axialkraft auf die Spindel (18, 1018) in der Rückwärtsrichtung aufgebracht wird, jede der Vielzahl von Kugeln entlang des Randes von der Verriegelungsposition in die Entriegelungsposition bewegt wird.

Revendications

1. Marteau perforateur (10, 1010) comprenant :

un mécanisme d'entraînement (14, 1014) comportant un moteur électrique (22) et une boîte de vitesses (26, 1026) ;
 un boîtier (30, 1030) renfermant au moins une partie du mécanisme d'entraînement ;
 une broche (18, 1018) rotative en réponse à la réception d'un couple à partir du mécanisme d'entraînement ;
 un premier cliquet (42, 1042) accouplé pour une co-rotation avec la broche ;
 un second cliquet (46, 1046) fixé de manière rotative au boîtier ;
 un mécanisme de verrouillage du marteau (90, 90a, 1174) réglable entre un premier mode et un second mode, le mécanisme de verrouillage du marteau comportant un cran mobile entre une position de verrouillage et une position de déverrouillage ;
 un embrayage (78, 1078) réglable entre un premier état dans lequel un couple de sortie de la broche est une valeur maximale prédéterminée, et un second état dans lequel le couple de sortie de la broche est limité à une valeur inférieure à la valeur maximale prédéterminée ; et
 un collier (74, 1074) accouplé de manière rotative au boîtier,

caractérisé en ce que le collier (74, 1074) est mobile entre une première position de rotation dans laquelle le mécanisme de verrouillage du marteau est dans le premier mode et l'embrayage dans le premier état, une deuxième position de rotation dans laquelle le mécanisme de verrouillage du marteau est dans le second mode et l'embrayage dans le premier état, et une troisième position de rotation dans laquelle le mécanisme de verrouillage du marteau est dans le second mode et l'embrayage dans le second état,

dans lequel, dans le premier mode, le cran peut se déplacer de la position de verrouillage à la position de déverrouillage, de sorte que la broche peut se déplacer par rapport au boîtier en réponse à un contact avec une pièce à usiner, amenant les premier et second cliquets à venir en prise, et dans lequel, dans le second mode, le cran est empêché de se déplacer de la position de verrouillage à la position de déverrouillage, de sorte que la broche est bloquée par le cran et ne peut se déplacer par rapport au boîtier en réponse à un contact avec une pièce à usiner et qu'un espace est maintenu entre les premier et second cliquets.

2. Marteau perforateur (10, 1010) selon la revendication 1, dans lequel le mécanisme de verrouillage du marteau (90,

EP 3 606 702 B1

90a, 1174) comporte une ouverture (A1, A2, A3, A4, A5) dans le boîtier et le cran est une bille (98, 98a, 1102, B1, B2, B3, B4, B5) agencée dans l'ouverture, et dans lequel la bille peut être déplacée à l'intérieur de l'ouverture entre la position de verrouillage et la position de déverrouillage.

- 5 **3.** Marteau perforateur (10, 1010) selon la revendication 2, dans lequel le collier (74, 1074) comporte un évidement (R1, R2, R3, R4, R5), et dans lequel lorsque le collier est dans la première position de rotation, l'ouverture est alignée avec l'évidement, et dans lequel lorsque le collier est dans les deuxième et troisième positions de rotation, l'ouverture n'est pas alignée avec l'évidement, et dans lequel la bille est au moins partiellement reçue dans l'évidement lorsque la bille est dans la position de déverrouillage.
- 10
- 4.** Marteau perforateur (10, 1010) selon la revendication 2, dans lequel le mécanisme de verrouillage du marteau comporte un premier palier (50, 1050) supportant de manière rotative la broche (18, 1018), et dans lequel, lorsque le collier (74, 1074) est dans les deuxième et troisième positions de rotation, la bille en position de verrouillage empêche le premier palier de se déplacer par rapport au boîtier en réponse à une force axiale appliquée à la broche dans une direction arrière.
- 15
- 5.** Marteau perforateur (10, 1010) selon la revendication 4, dans lequel le second cliquet (46, 1046) comporte une poche (62, 1062), et dans lequel un second palier (66, 1066) qui supporte de manière rotative la broche est au moins partiellement positionné dans la poche.
- 20
- 6.** Marteau perforateur (10, 1010) selon la revendication 4, dans lequel le premier palier comporte un bord (54, 1054) qui entre en contact avec la bille lorsque la bille est en position de verrouillage et que la force axiale est appliquée à la broche dans la direction arrière.
- 25
- 7.** Marteau perforateur (10, 1010) selon la revendication 6, dans lequel, lorsque le collier est dans la première position de rotation et que la force axiale est appliquée à la broche dans la direction arrière, la bille est déplacée le long du bord de la position de verrouillage à la position de déverrouillage, et éventuellement, dans lequel le bord a une forme choisie dans le groupe constitué de concave, chanfreiné, et une combinaison de concave et chanfreiné.
- 30
- 8.** Marteau perforateur (10, 1010) selon la revendication 1, dans lequel le second cliquet (46, 1046) est fixé axialement par rapport au boîtier (30, 1030).
- 35
- 9.** Marteau perforateur (10, 1010) selon la revendication 1, dans lequel le second cliquet comporte une poche (62, 1062), et dans lequel un palier (50, 1050) qui supporte de manière rotative la broche est au moins partiellement positionné dans la poche.
- 10.** Marteau perforateur (10, 1010) selon la revendication 1, dans lequel l'embrayage (78, 1078) est un embrayage électronique, et éventuellement :
- 40
- (i) dans lequel l'embrayage électronique comprend :
- une carte de circuit imprimé (82) ayant une pluralité de pastilles électroniques (86) correspondant à différentes valeurs du couple de sortie du moteur électrique (22) ; et
- 45
- un racleur accouplé en co-rotation avec le collier (74, 1074), dans lequel le racleur est en contact électrique avec les pastilles lorsque le collier tourne par rapport à la carte de circuit imprimé ; ou
- 50
- (ii) dans lequel l'embrayage électronique comporte un ou plusieurs parmi un potentiomètre, un capteur à effet Hall et un capteur inductif.
- 11.** Marteau perforateur (10, 1010) selon la revendication 1, dans lequel l'embrayage (78, 1078) est un embrayage mécanique.
- 55
- 12.** Marteau perforateur (10, 1010) selon la revendication 11, dans lequel la boîte de vitesses (26, 1026) est une boîte de vitesses à trains planétaires à plusieurs étages ayant une couronne (1094), dans lequel l'embrayage mécanique comporte une surface d'embrayage (1098) définie dans la couronne et une pluralité de suiveurs (1102) venant en

prise avec la surface d'embrayage, dans lequel dans le premier état, les suiveurs sont sollicités contre la surface d'embrayage à une première valeur de précharge, et dans lequel dans le second état, les suiveurs sont sollicités contre la surface d'embrayage à une seconde valeur de précharge,

5 et éventuellement, dans lequel l'embrayage mécanique comporte un dispositif de retenue (1122) dans lequel une pluralité de ressorts (1130) sont reçus, chacun des ressorts sollicitant respectivement l'un des suiveurs contre la surface de l'embrayage, et dans lequel un mouvement du collier (74, 1074) de la première position de rotation à la deuxième position de rotation déplace le dispositif de retenue d'une première position axiale à une deuxième position axiale, et dans lequel un mouvement du collier de la deuxième position de rotation à la troisième position de rotation déplace le dispositif de retenue de la deuxième position axiale à une troisième position axiale, et, en outre, éventuellement :

10 (i) dans lequel le dispositif de retenue comporte une première partie filetée (1126) qui vient en prise de manière filetée à l'intérieur d'une seconde partie filetée (1128) du collier ; ou
 15 (ii) dans lequel la surface d'embrayage comporte une pluralité de rampes (1106) s'étendant à une première distance de la surface d'embrayage, et dans lequel l'embrayage mécanique comporte un disque d'embrayage (1090) entre les ressorts et les suiveurs,

et, en outre, éventuellement :

20 (a) dans lequel un espace réglable est défini entre le disque d'embrayage et le dispositif de retenue, l'espace réglable définissant une seconde distance, et dans lequel un mouvement du dispositif de retenue de la première position axiale à la deuxième position axiale augmente la seconde distance de l'espace réglable,

25 et en outre, éventuellement, dans lequel lorsque la seconde distance est supérieure à la première distance, l'embrayage réduit un couple de sortie de la broche, et dans lequel lorsque la seconde distance est inférieure à la première distance, l'embrayage est verrouillé, transférant ainsi un couple maximal développé par le moteur à la broche (18, 1018),

30 et en outre, éventuellement, dans lequel lorsque le collier est dans la première position de rotation, la seconde distance est inférieure à la première distance ; ou

(b) dans lequel l'embrayage mécanique comporte une pluralité de goupilles (1082), avec une goupille agencée entre chaque suiveur et le disque d'embrayage.

35 **13.** Marteau perforateur (10, 1010) comprenant :

un mécanisme d'entraînement (14, 1014) comportant un moteur électrique (22) et une boîte de vitesse (26, 1026) ;

un boîtier (30, 1030) renfermant au moins une partie du mécanisme d'entraînement ;

40 une broche (18, 1018) agencée dans le boîtier et rotative en réponse à la réception d'un couple provenant du mécanisme d'entraînement ;

un premier cliquet (42, 1042) agencé dans le boîtier et accouplé en co-rotation avec la broche ;

un second cliquet (46, 1046) fixé de manière rotative au boîtier ;

45 un mécanisme de verrouillage de marteau (90, 90a, 1174) comportant une pluralité d'ouvertures (A1, A2, A3, A4, A5) dans le boîtier et une bille (98, 98a, 1102, B1, B2, B3, B4, B5) agencée dans chacune des ouvertures ;

un embrayage (78, 1078) réglable entre un premier état dans lequel un couple de sortie de la broche est une valeur maximale prédéterminée, et un second état dans lequel le couple de sortie de la broche est limité à une valeur inférieure à la valeur maximale prédéterminée ; et

50 un collier (74, 1074) accouplé de manière rotative au boîtier et comportant une pluralité d'évidements (R1, R2, R3, R4, R5), **caractérisé en ce que** le collier est mobile entre une première position de rotation, dans laquelle chacun des évidements est aligné avec l'une des ouvertures et l'embrayage est dans le premier état, et une deuxième position de rotation, dans laquelle au moins un évidement n'est aligné avec aucune des ouvertures et l'embrayage est dans le premier état, et une troisième position de rotation, dans laquelle au moins un évidement n'est aligné avec aucune des ouvertures et l'embrayage est dans le second état,

55 dans lequel chacune des billes peut être déplacée à l'intérieur de son ouverture respective entre une position de déverrouillage, dans laquelle la bille est au moins partiellement reçue dans l'un des évidements du collier, et une position de verrouillage, dans laquelle la bille n'est reçue dans aucun des évidements du collier,

dans lequel, lorsque le collier est dans la première position de rotation, les billes sont chacune mobiles de la

EP 3 606 702 B1

position de verrouillage à la position de déverrouillage, de sorte que la broche est mobile par rapport au boîtier en réponse à une force axiale appliquée à la broche dans une direction arrière, permettant aux premier et second cliquets de venir en prise, et

dans lequel, lorsque le collier est dans les deuxième et troisième positions de rotation, au moins une bille est empêchée de se déplacer de la position de verrouillage à la position de déverrouillage, de sorte que l'au moins une bille en position de verrouillage empêche la broche de se déplacer par rapport au boîtier en réponse à la force axiale appliquée à la broche dans la direction arrière et qu'un espace est maintenu entre les premier et second cliquets.

14. Marteau perforateur (10, 1010) selon la revendication 13, dans lequel lorsque le collier (74, 1074) est dans les deuxième et troisième positions de rotation, au moins trois évidements (R1, R2, R3, R4, R5) ne sont alignés avec aucune des ouvertures (A1, A2, A3, A4, A5), de sorte qu'au moins trois billes (98, 98a, 1102, B1, B2, B3, B4, B5) sont empêchées de se déplacer de la position de verrouillage à la position de déverrouillage, ou dans lequel, lorsque le collier est dans les deuxième et troisième positions de rotation et qu'au moins une de la pluralité d'ouvertures est alignée avec l'un de la pluralité d'évidements, chaque ouverture alignée avec l'un des évidements est située entre deux ouvertures qui ne sont alignées avec aucun des évidements.

15. Marteau perforateur (10, 1010) selon la revendication 13, comprenant en outre un palier (50, 1050) supportant de manière rotative la broche (18, 1018), et dans lequel, lorsque le collier (74, 1074) est dans les deuxième et troisième positions de rotation, l'au moins une bille (98, 98a, 1102, B1, B2, B3, B4, B5) dans la position de verrouillage empêche le palier de se déplacer par rapport au boîtier en réponse à la force axiale appliquée à la broche dans la direction arrière, et éventuellement, dans lequel le palier comporte un bord (54, 1054), et dans lequel lorsque le collier est dans la première position de rotation et que la force axiale est appliquée à la broche (18, 1018) dans la direction arrière, chacune de la pluralité de billes est déplacée le long du bord de la position de verrouillage à la position de déverrouillage.

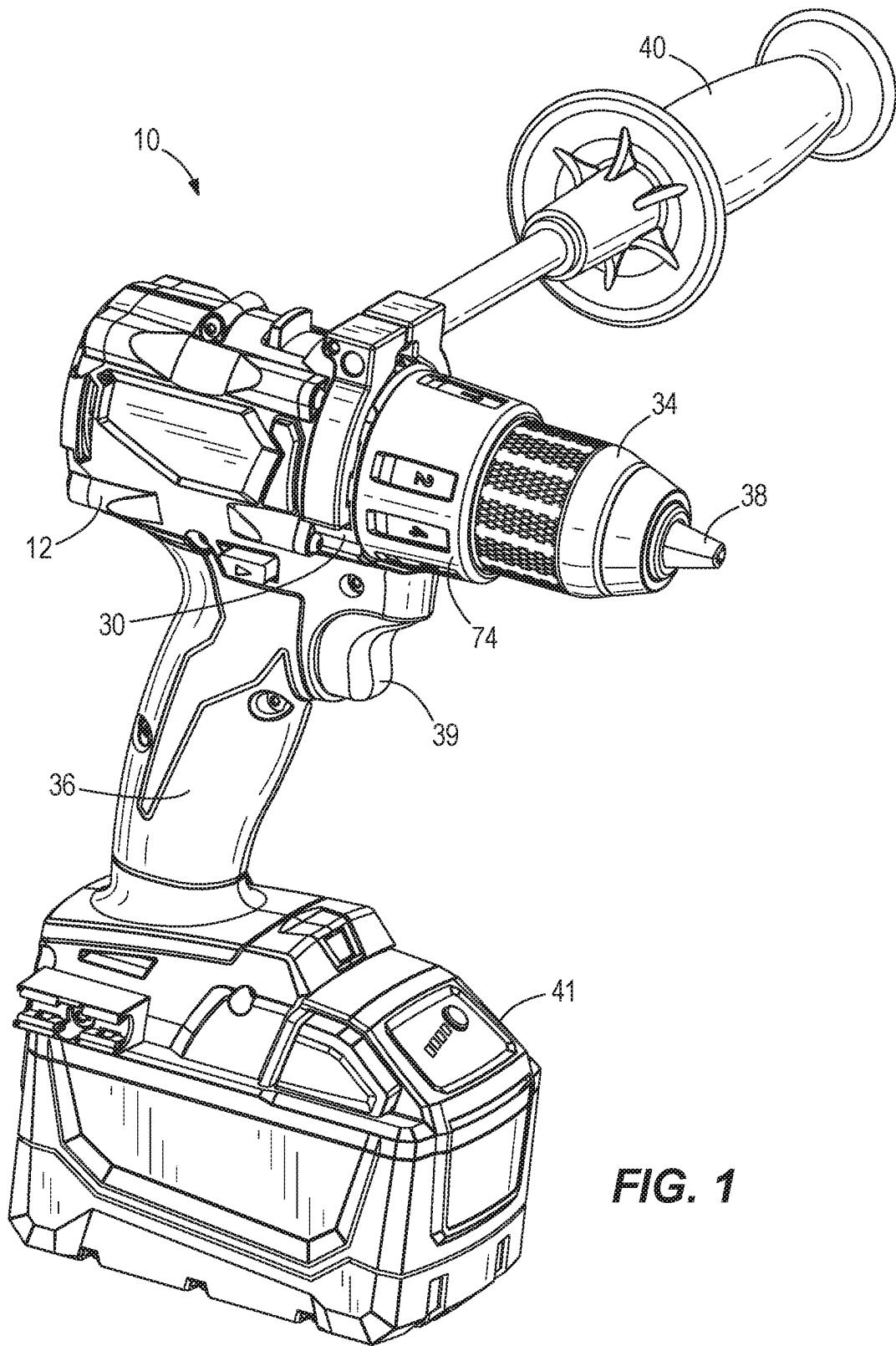

FIG. 1

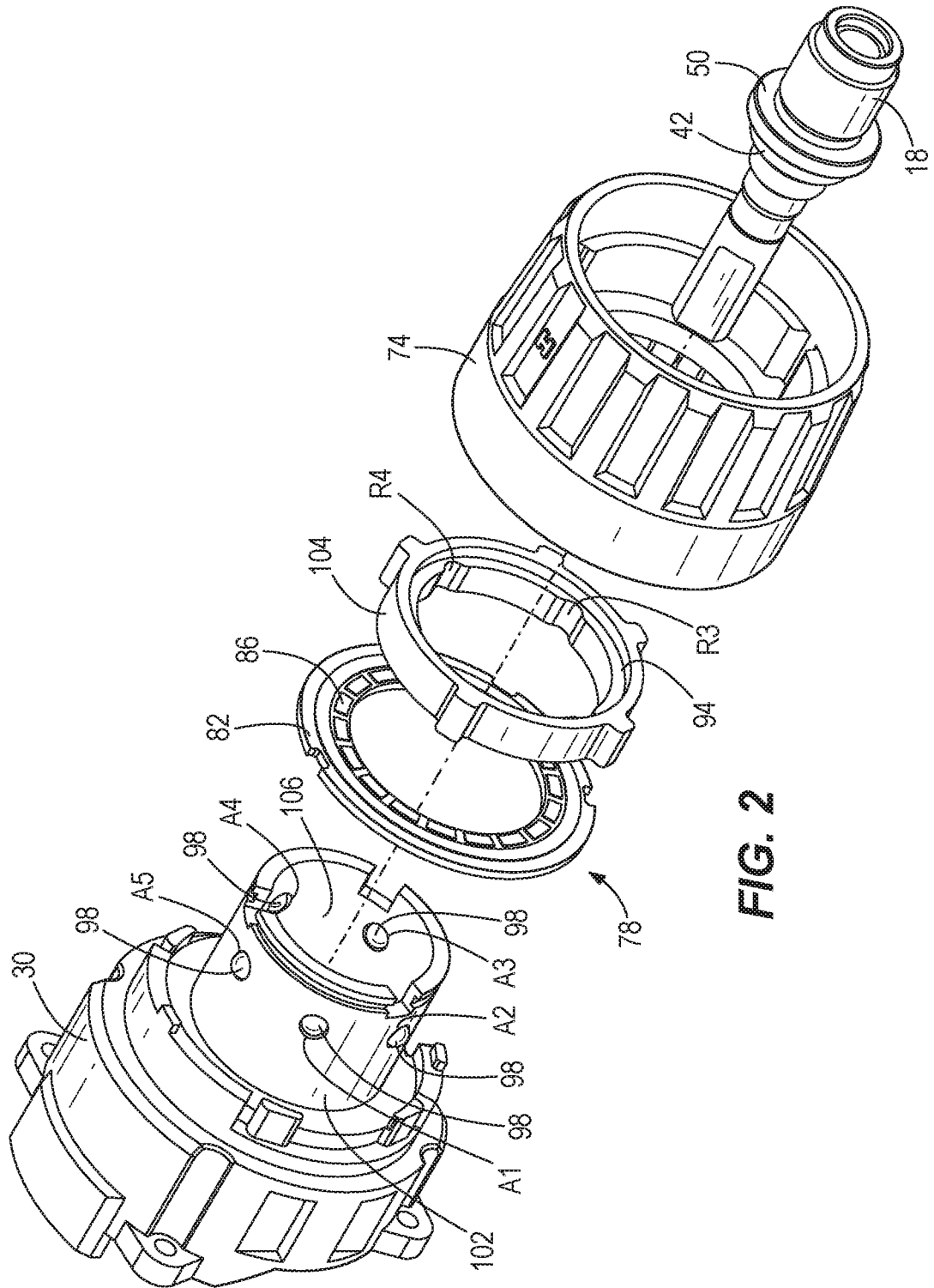

FIG. 2

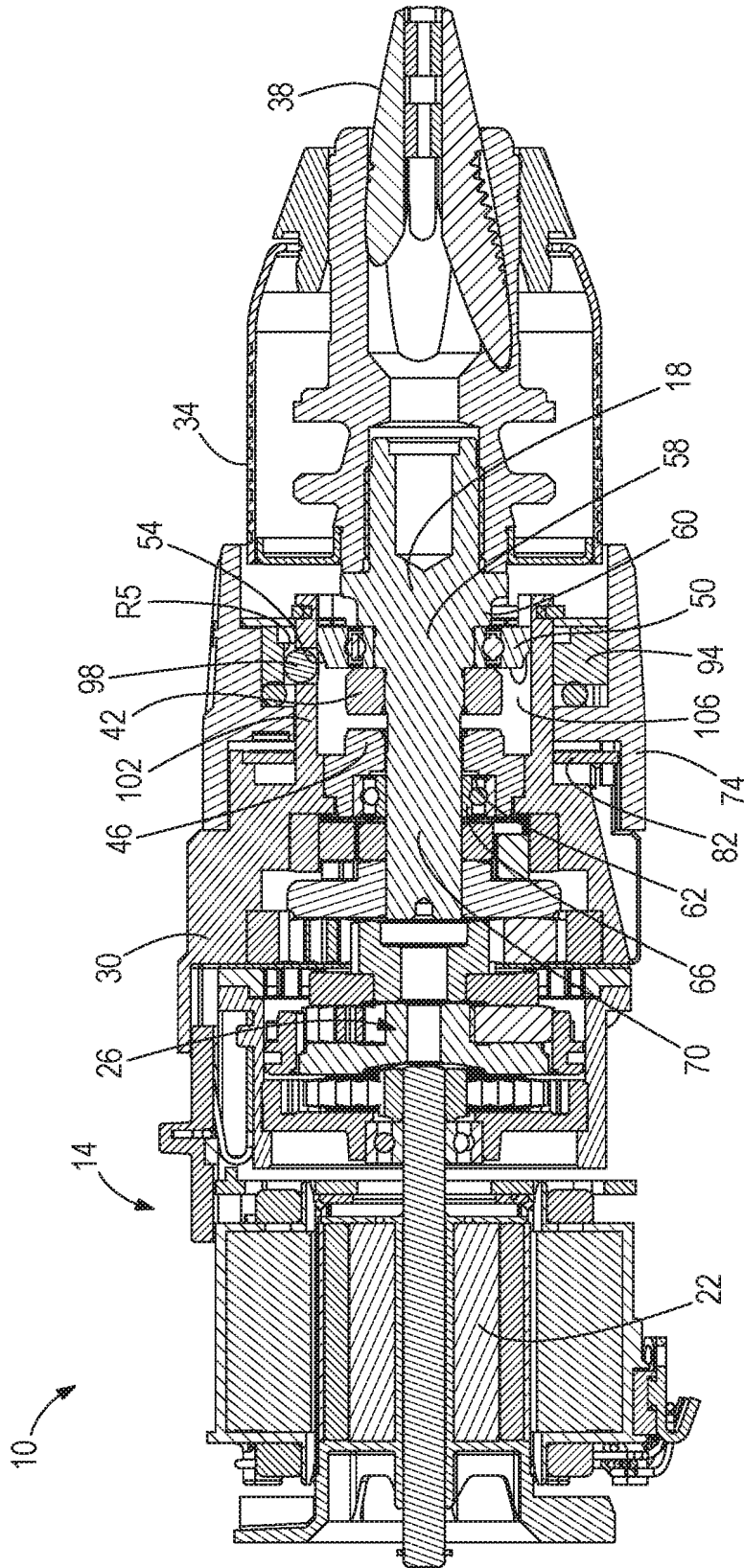

FIG. 3

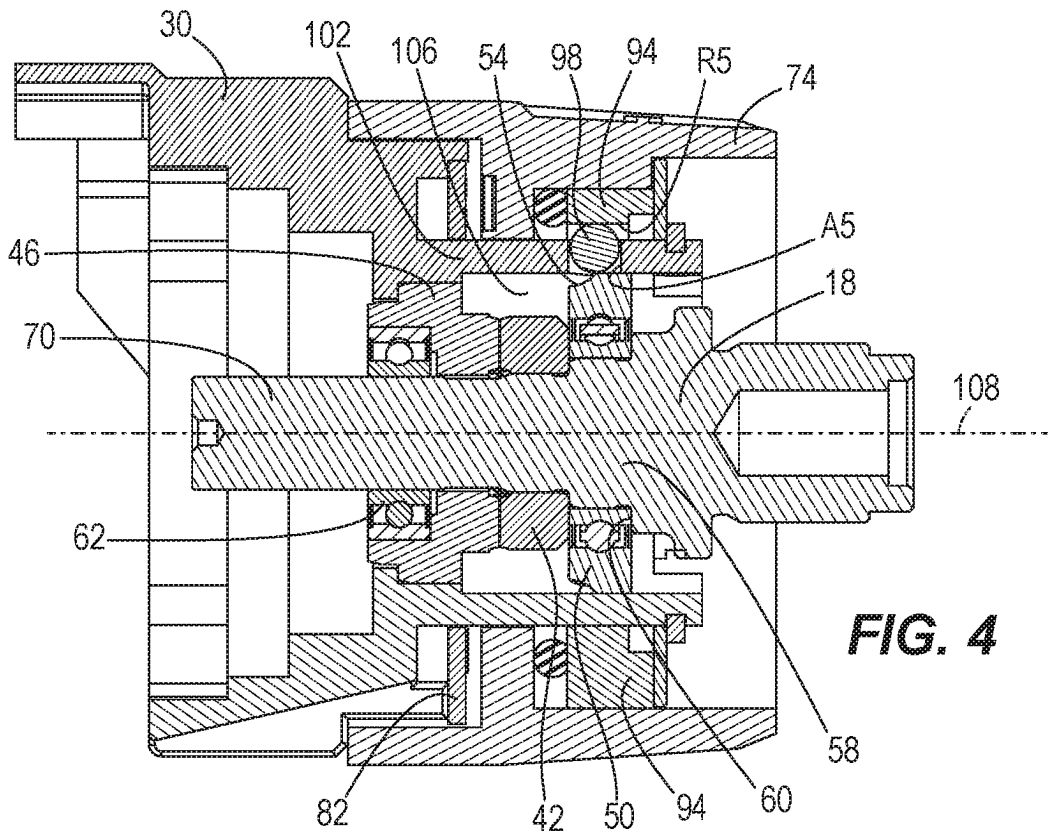

FIG. 4

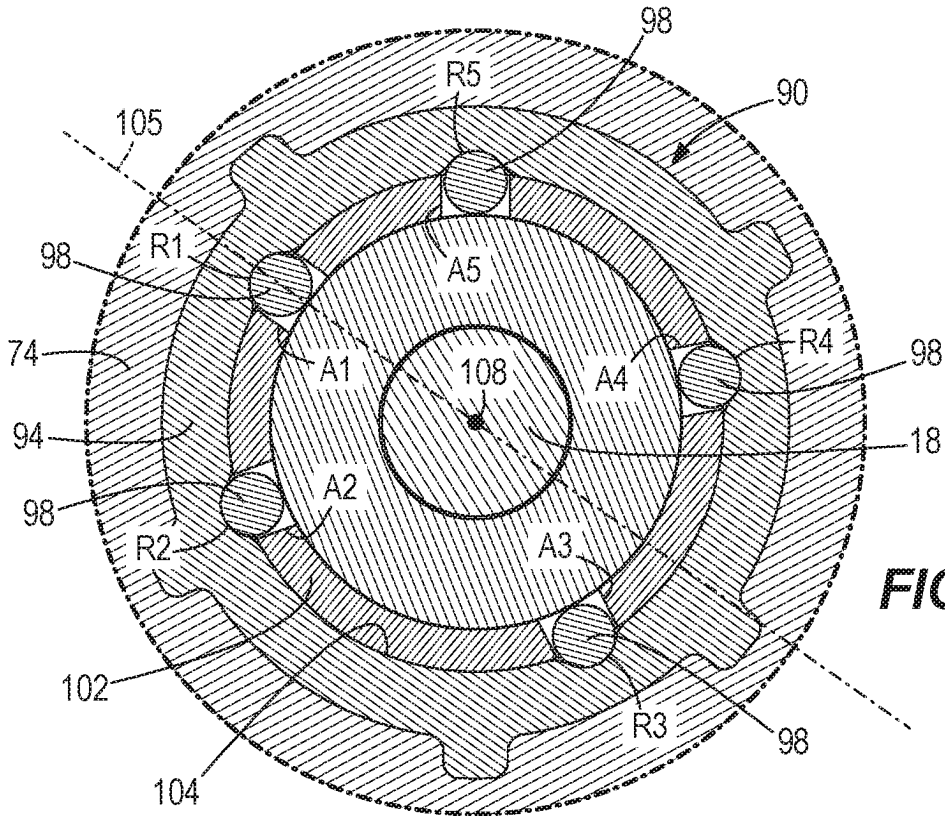

FIG. 5

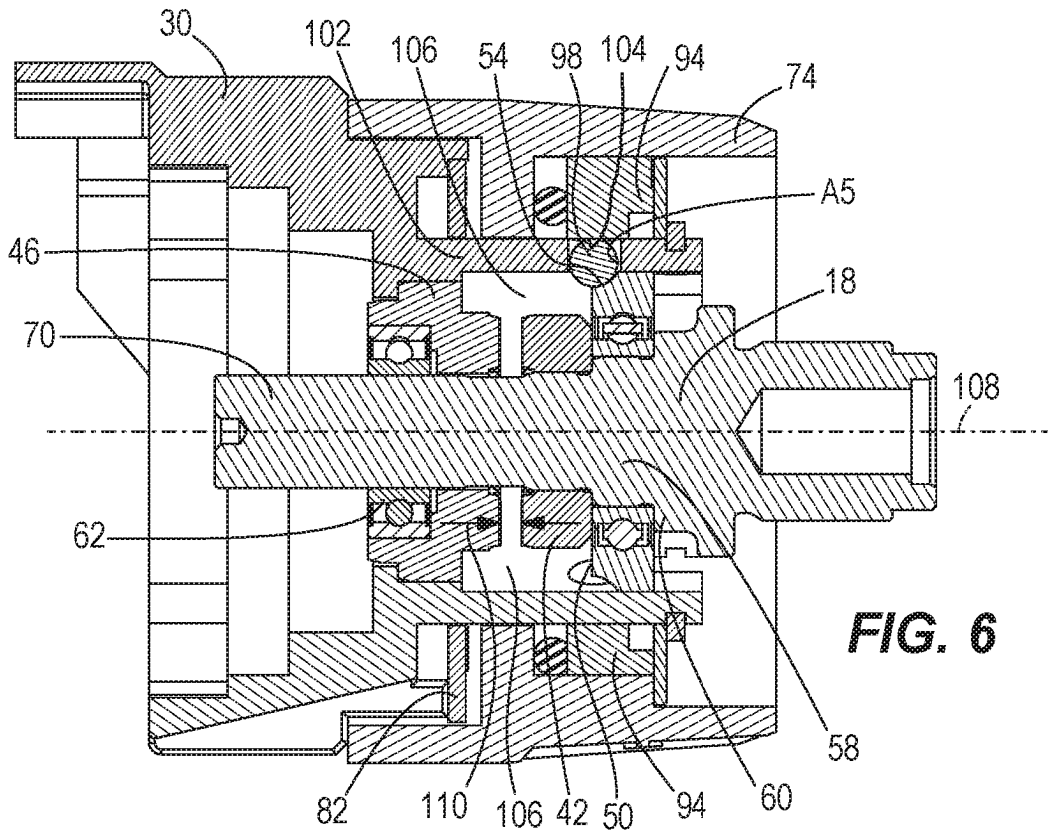

FIG. 6

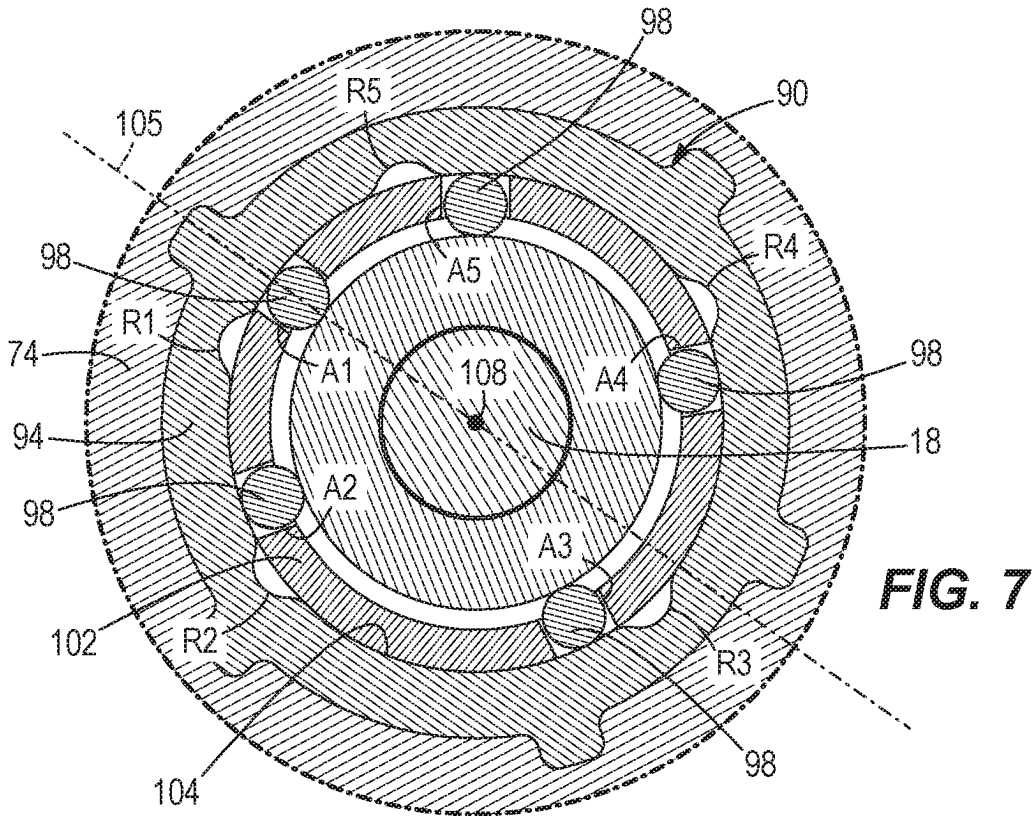

FIG. 7

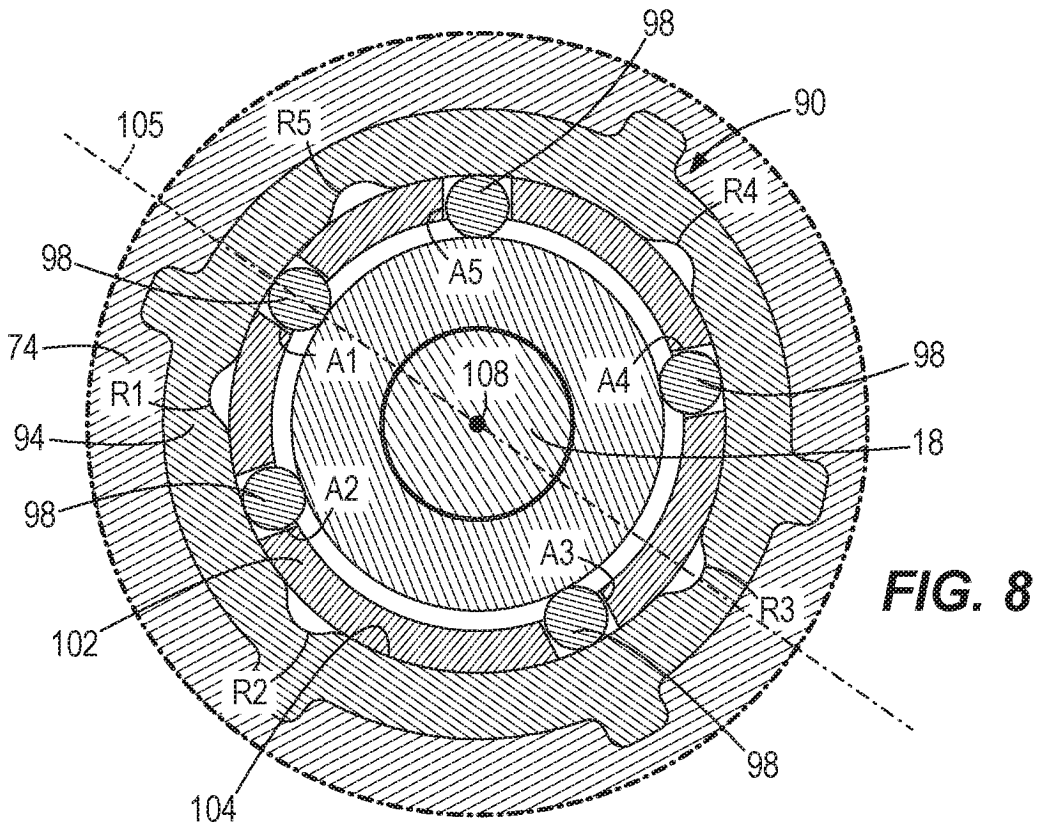

FIG. 8

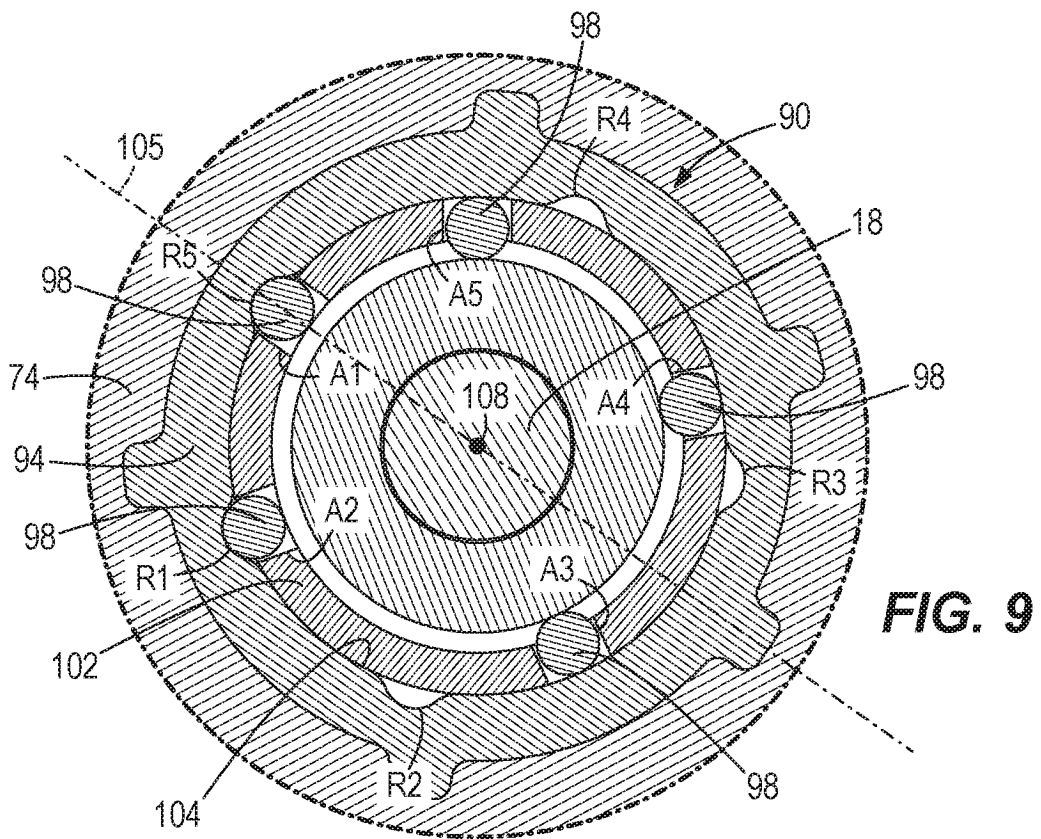

FIG. 9

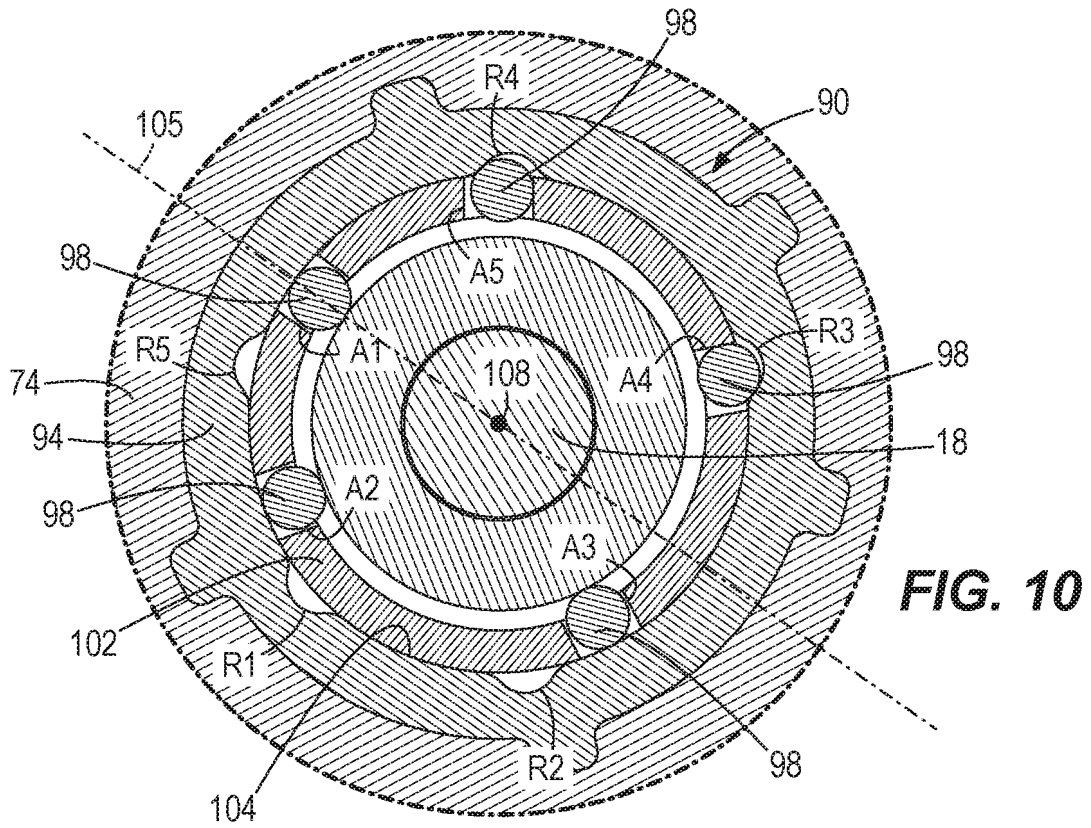

FIG. 10

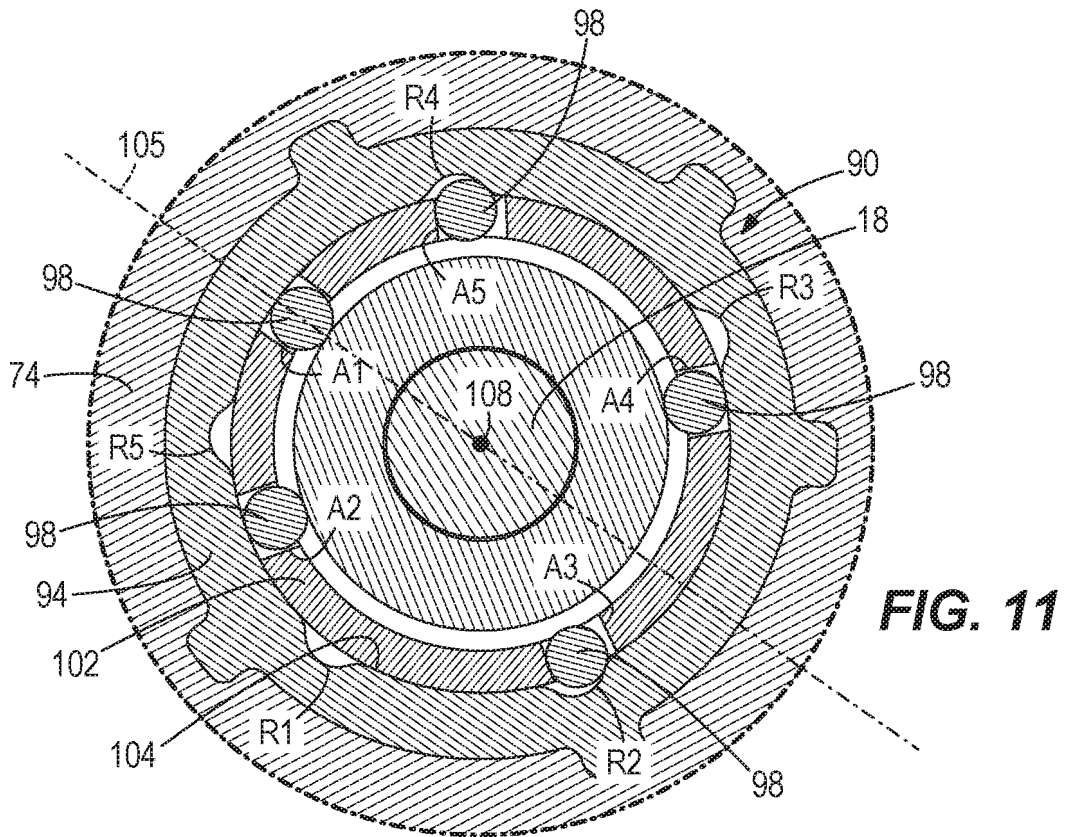

FIG. 11

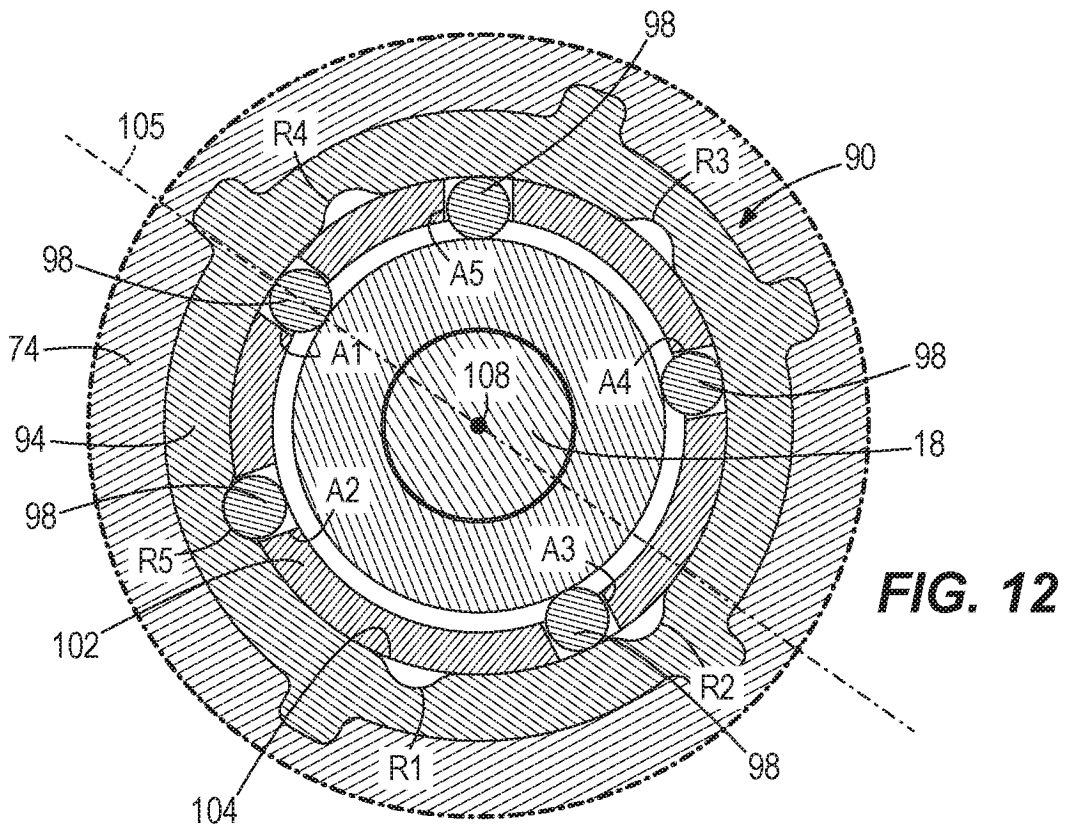

FIG. 12

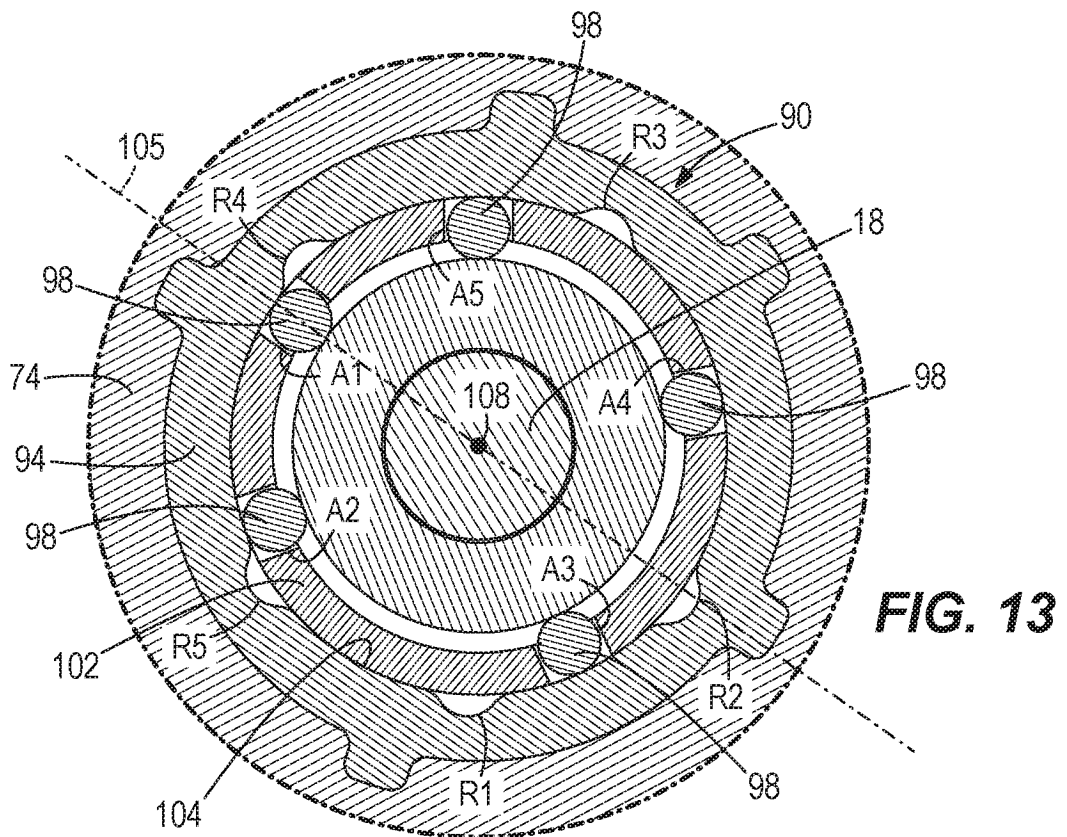

FIG. 13

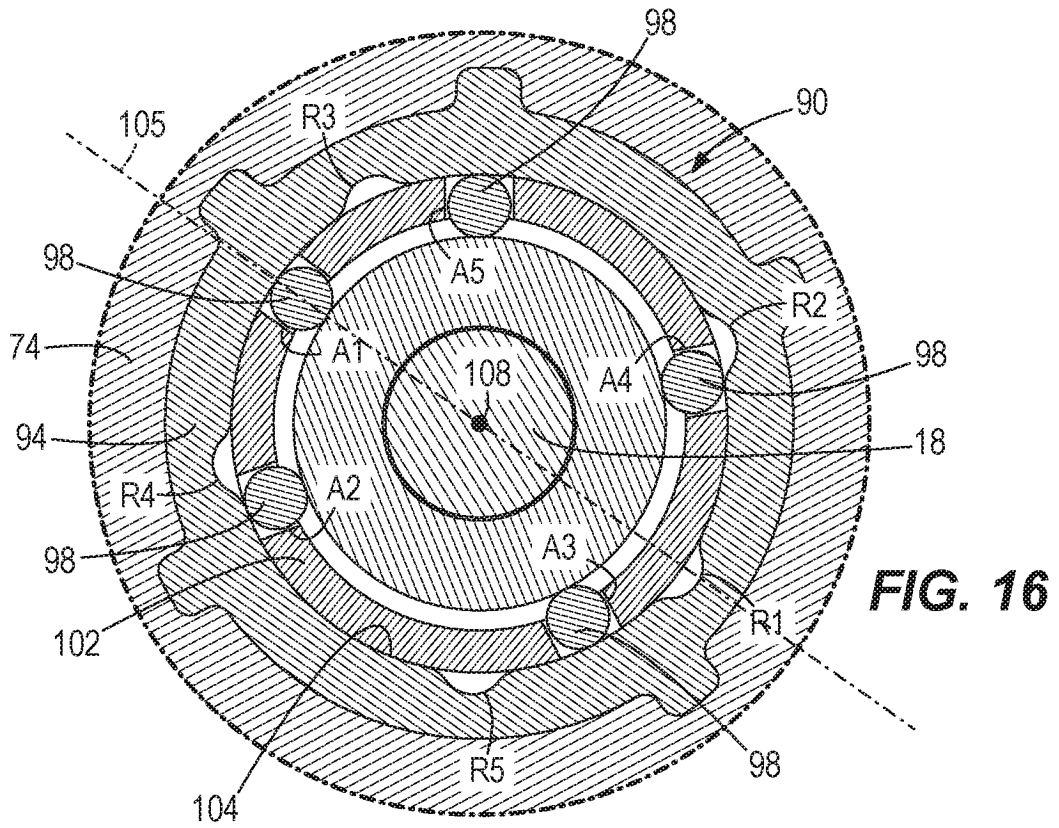

FIG. 16

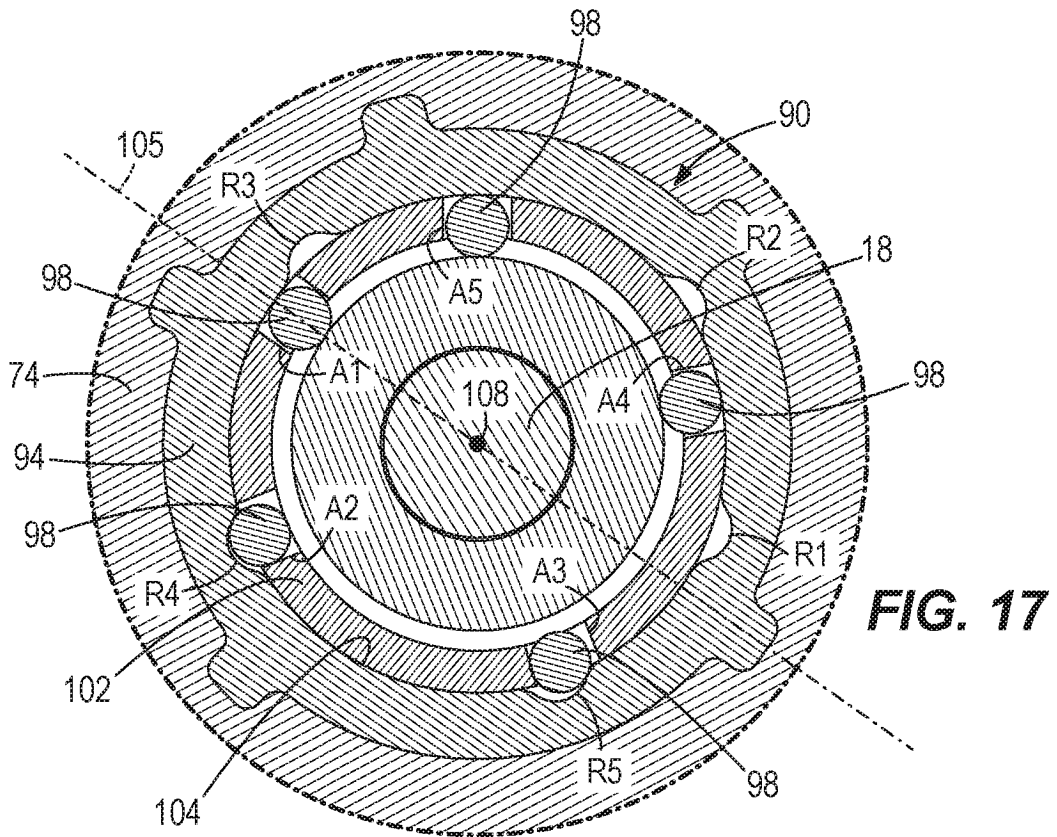

FIG. 17

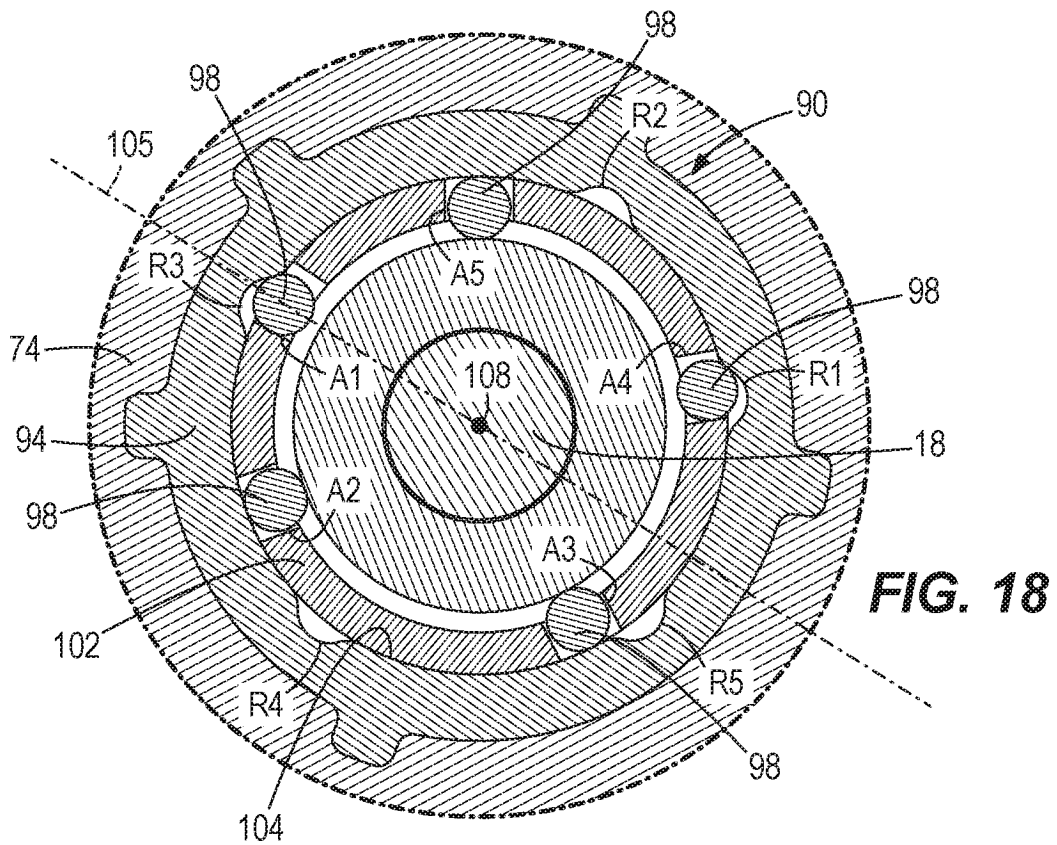

FIG. 18

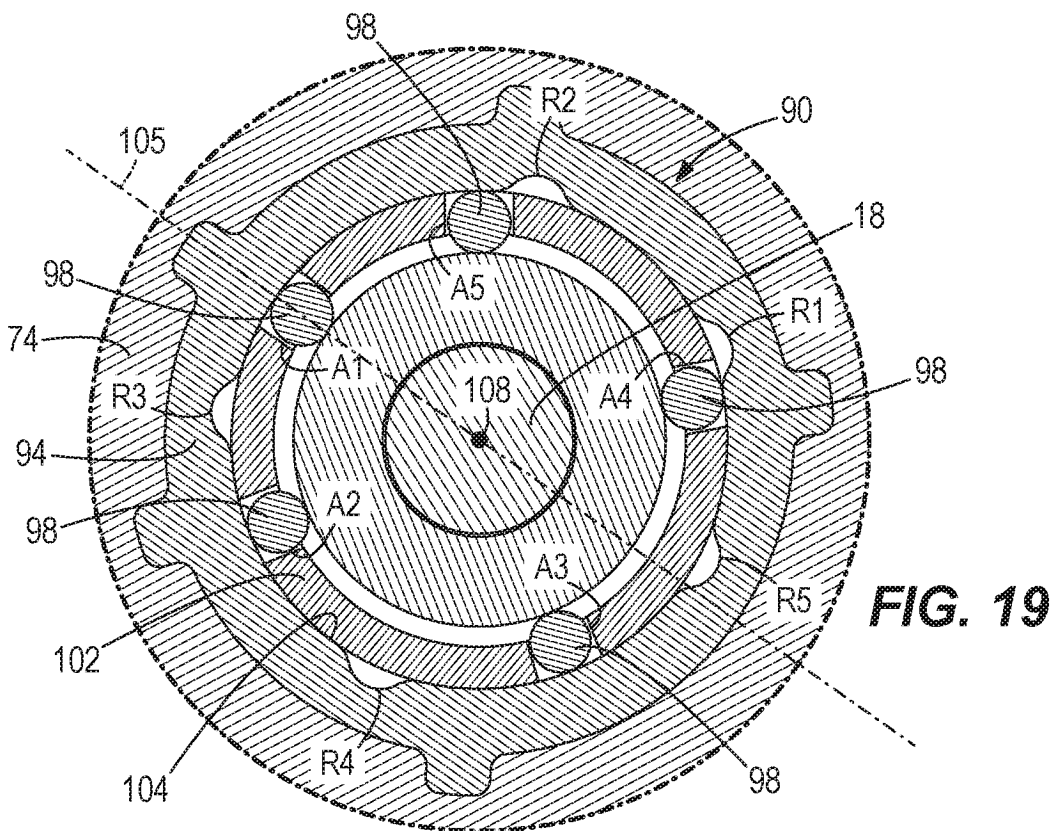

FIG. 19

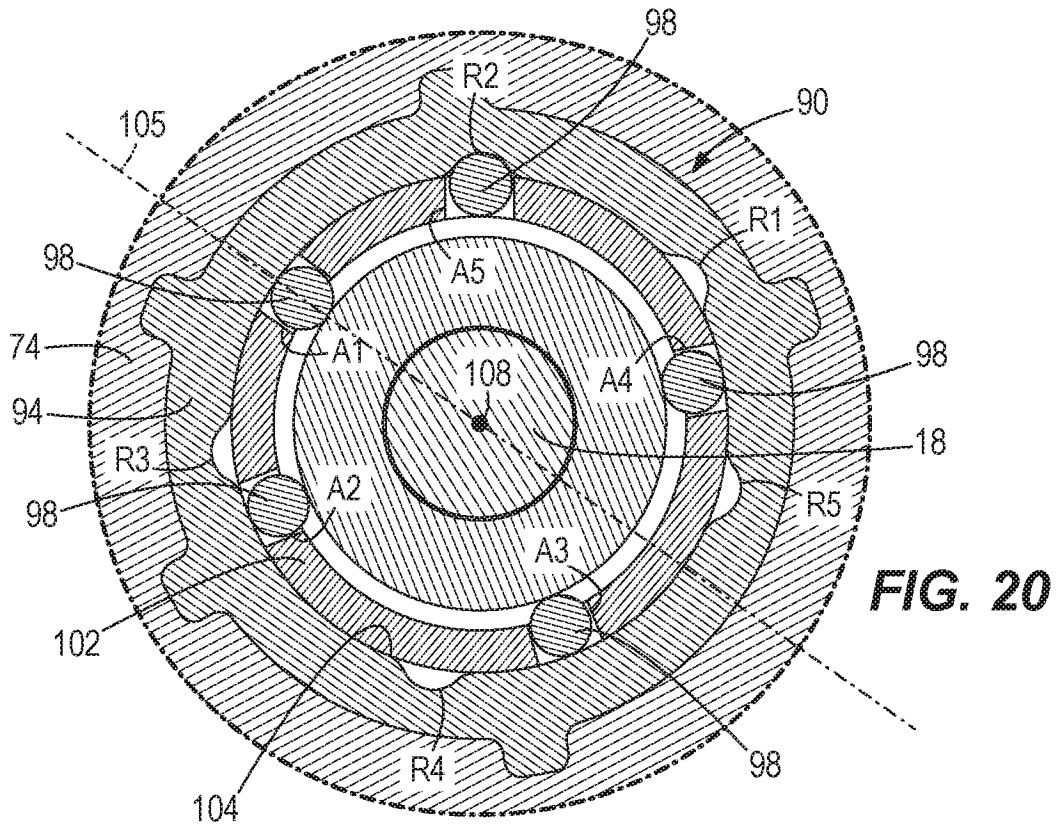

FIG. 20

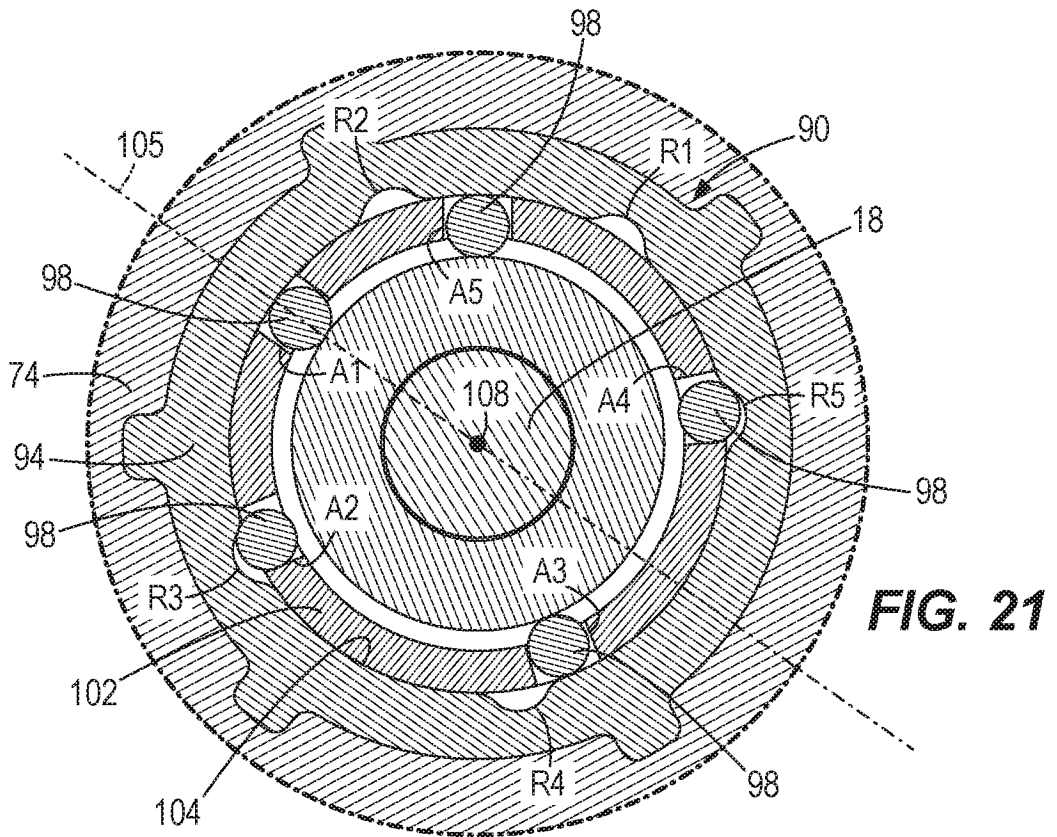

FIG. 21

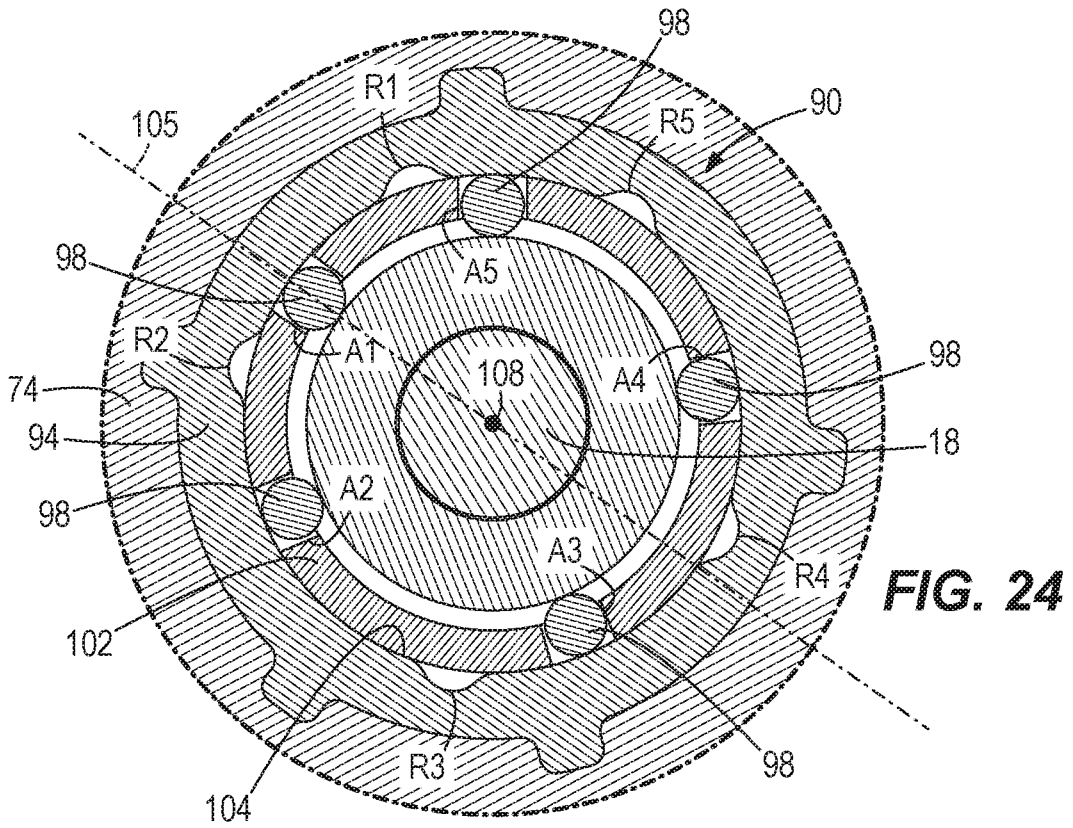

FIG. 24

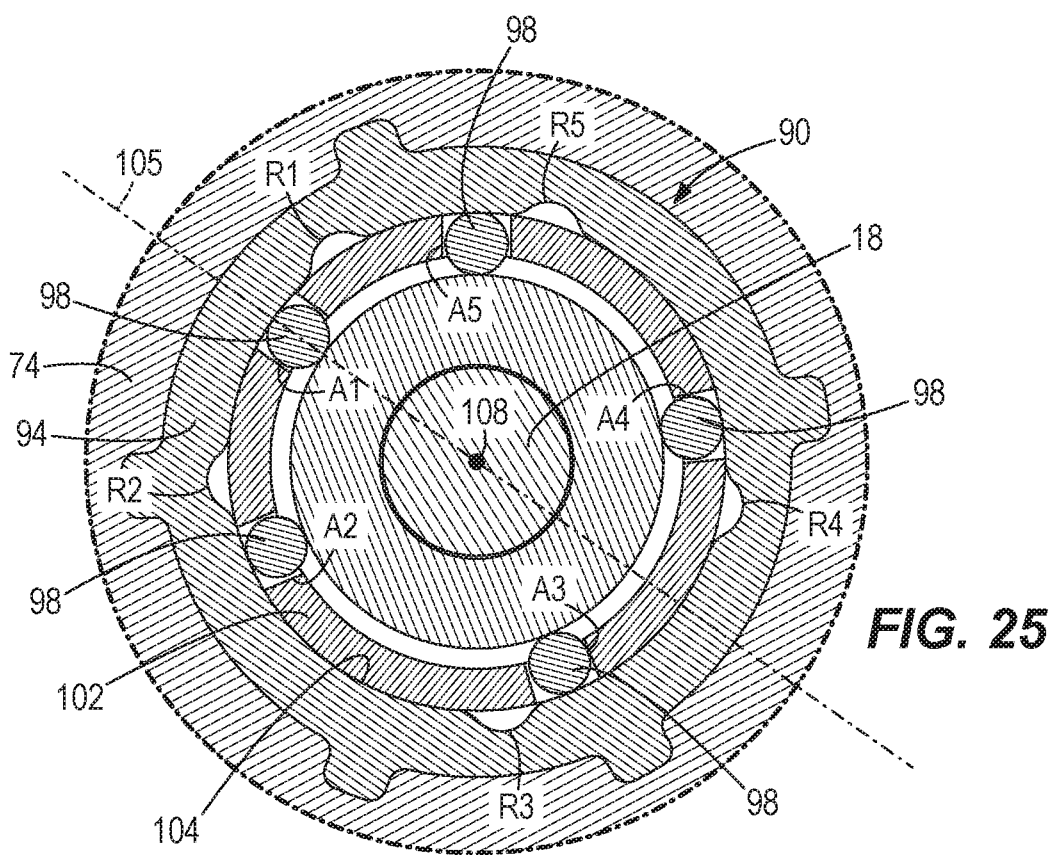

FIG. 25

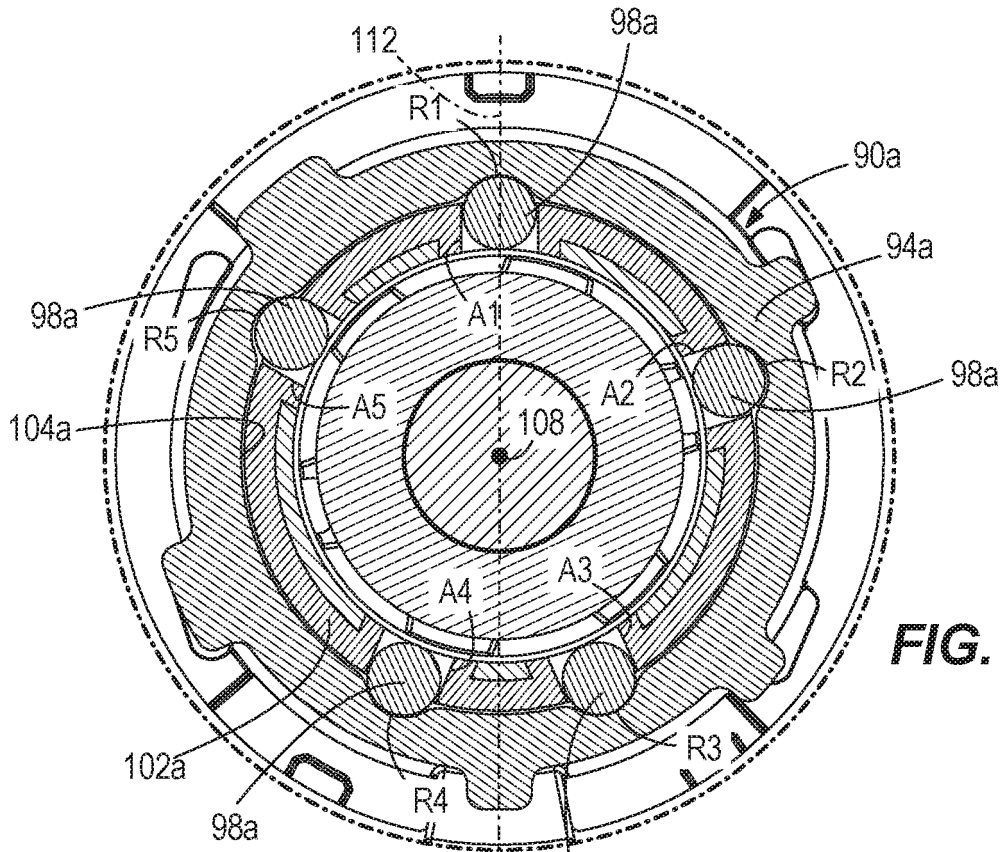

FIG. 26

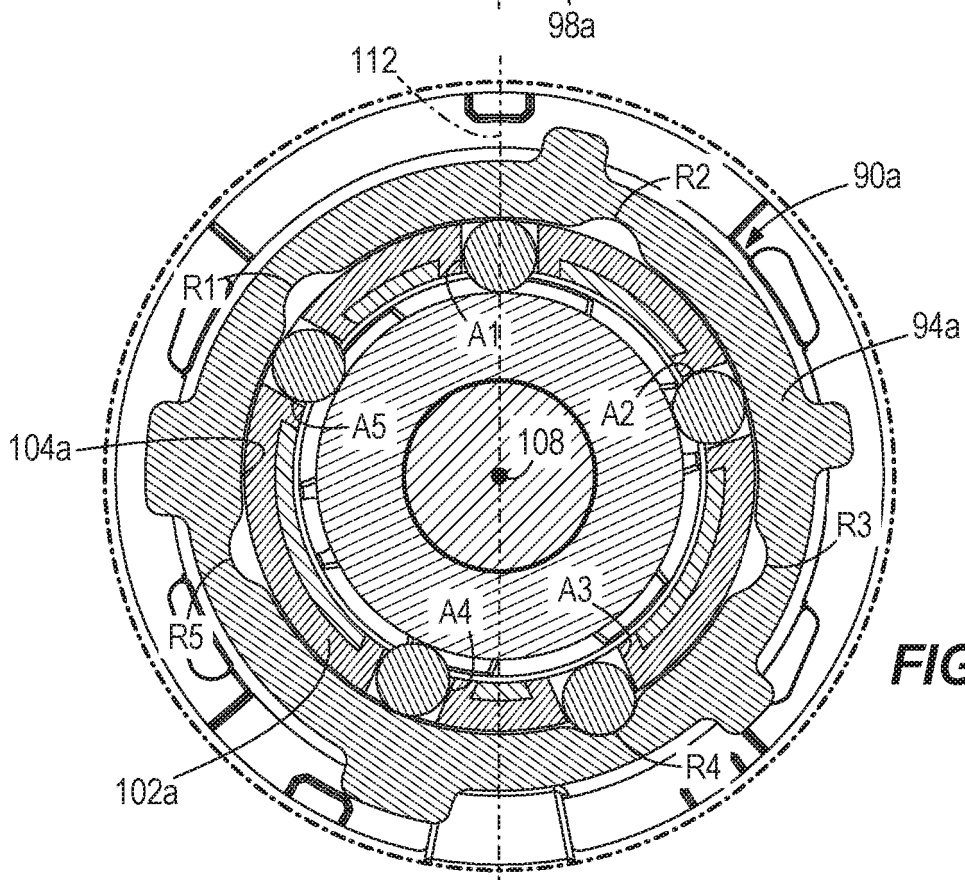

FIG. 27

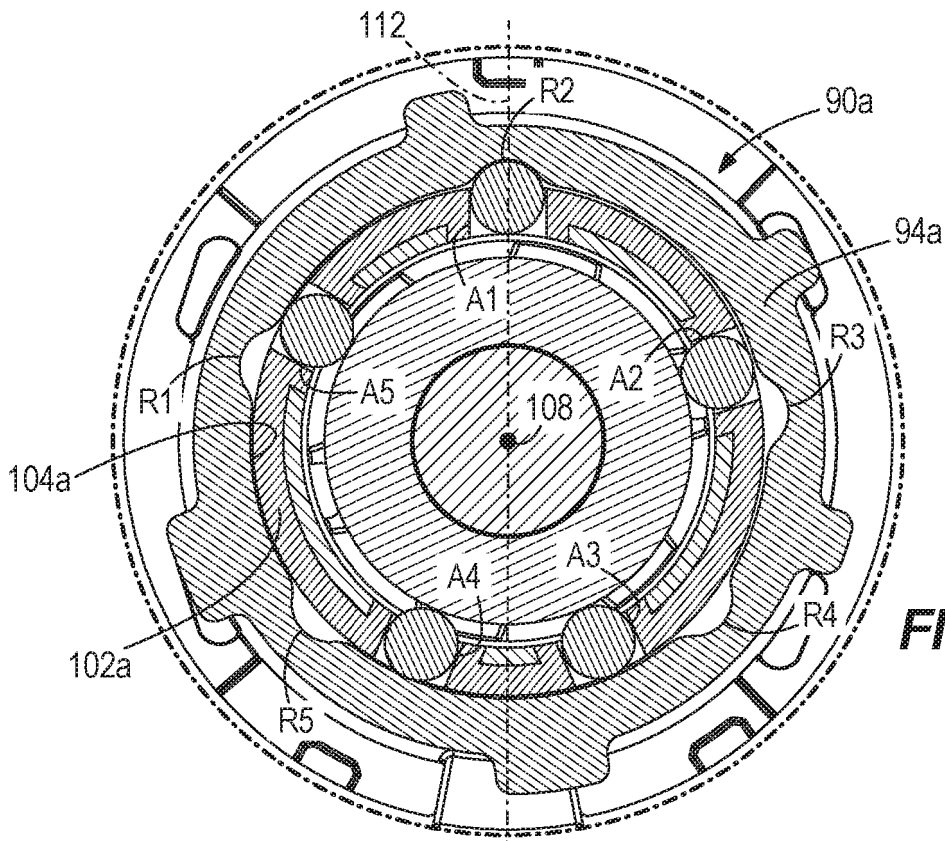

FIG. 28

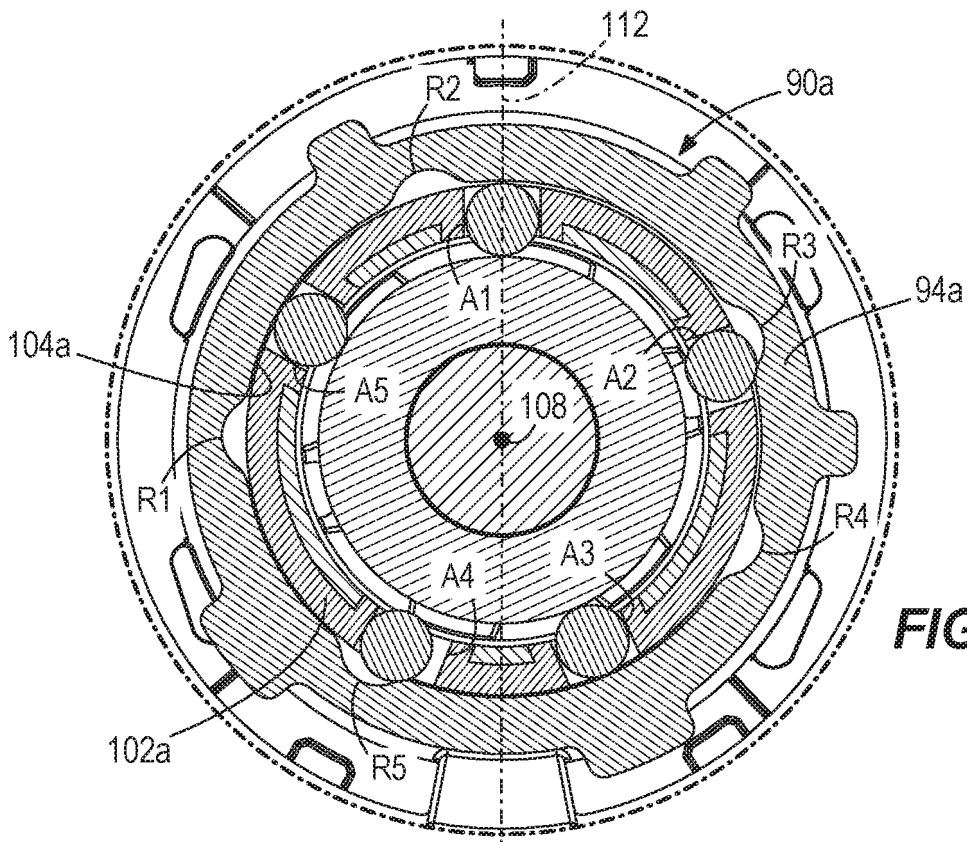

FIG. 29

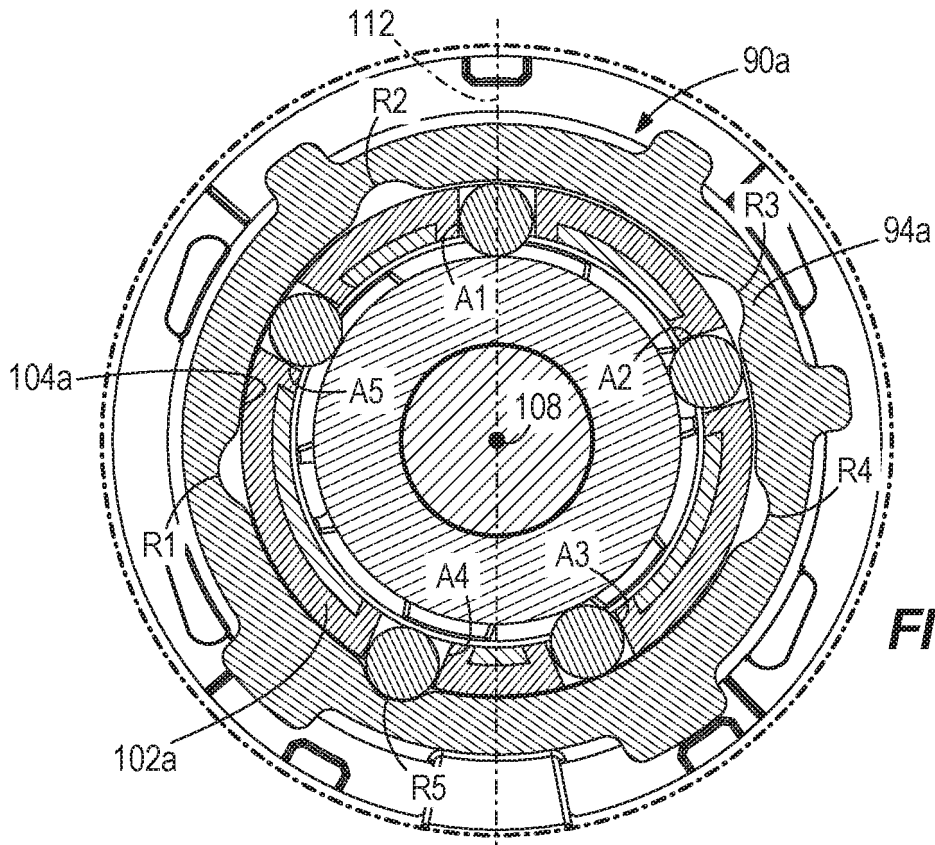

FIG. 30

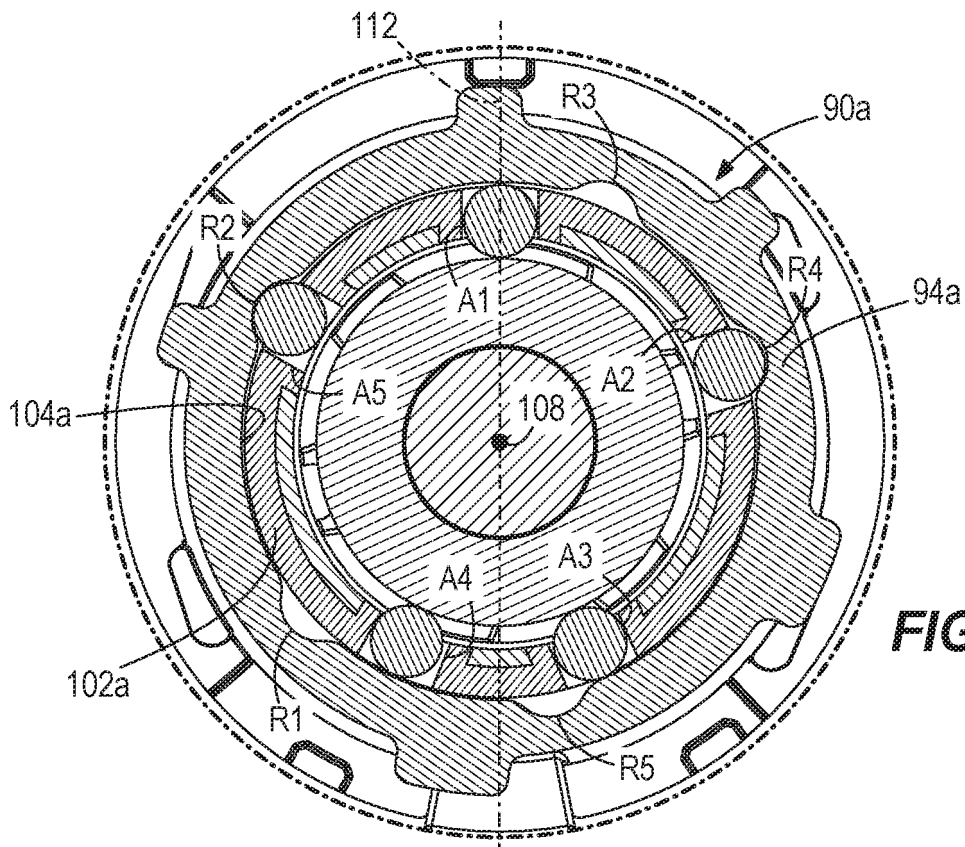

FIG. 31

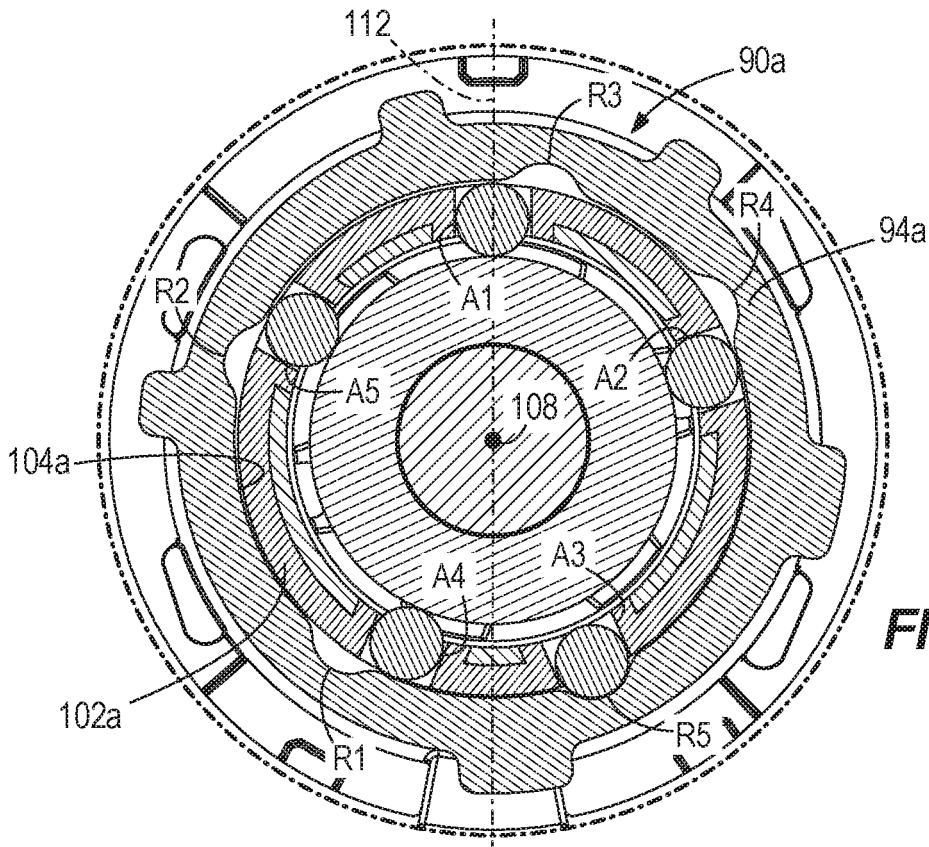

FIG. 32

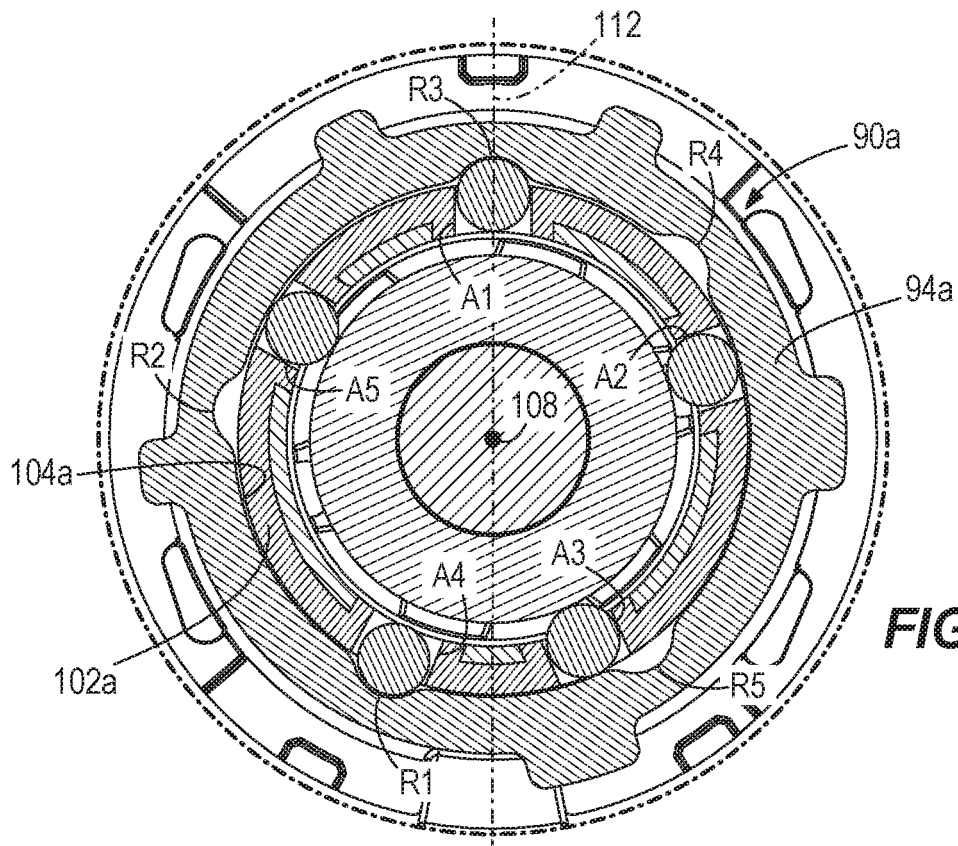

FIG. 33

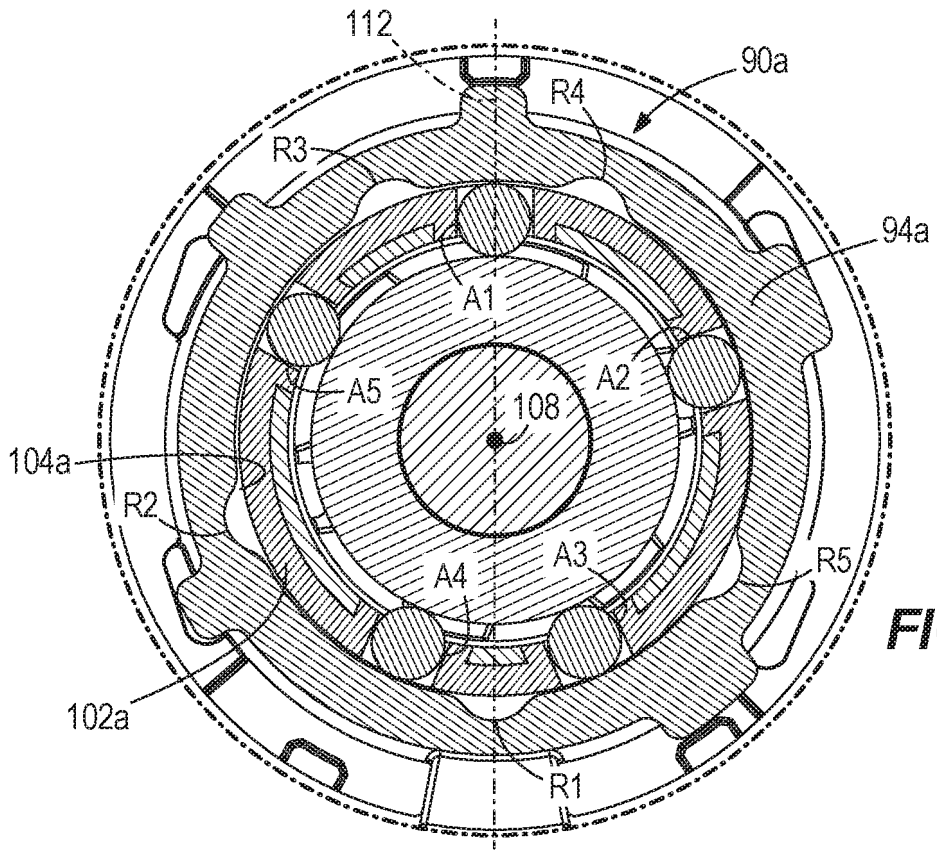

FIG. 34

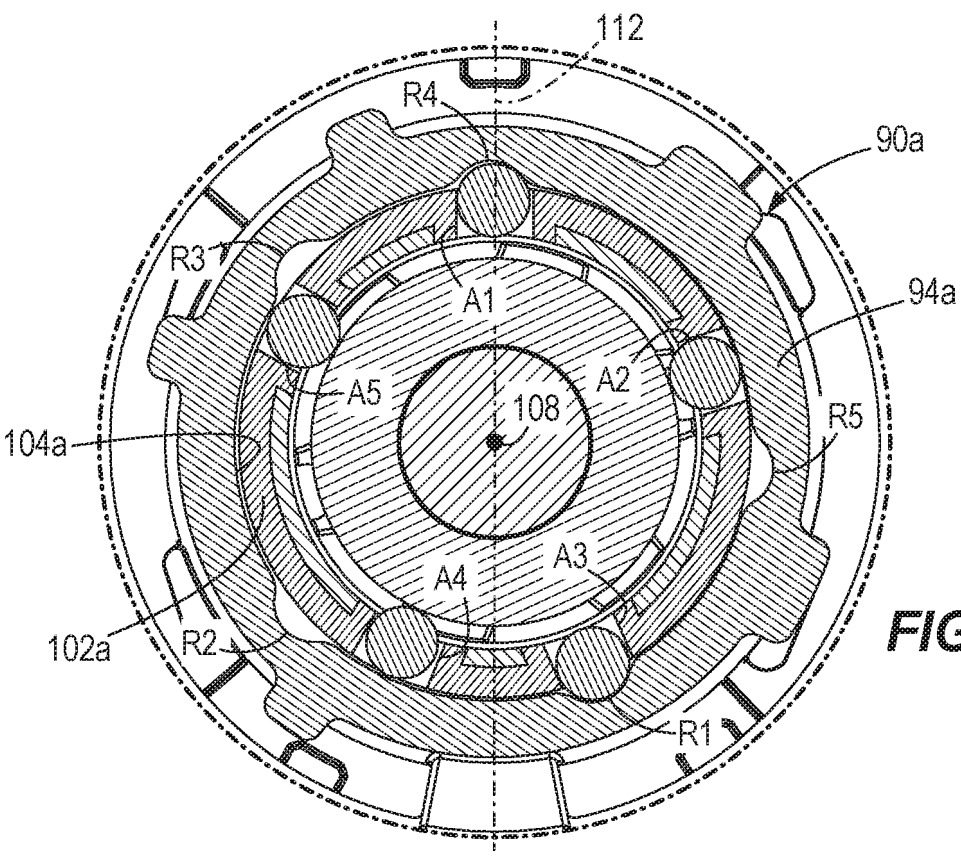

FIG. 35

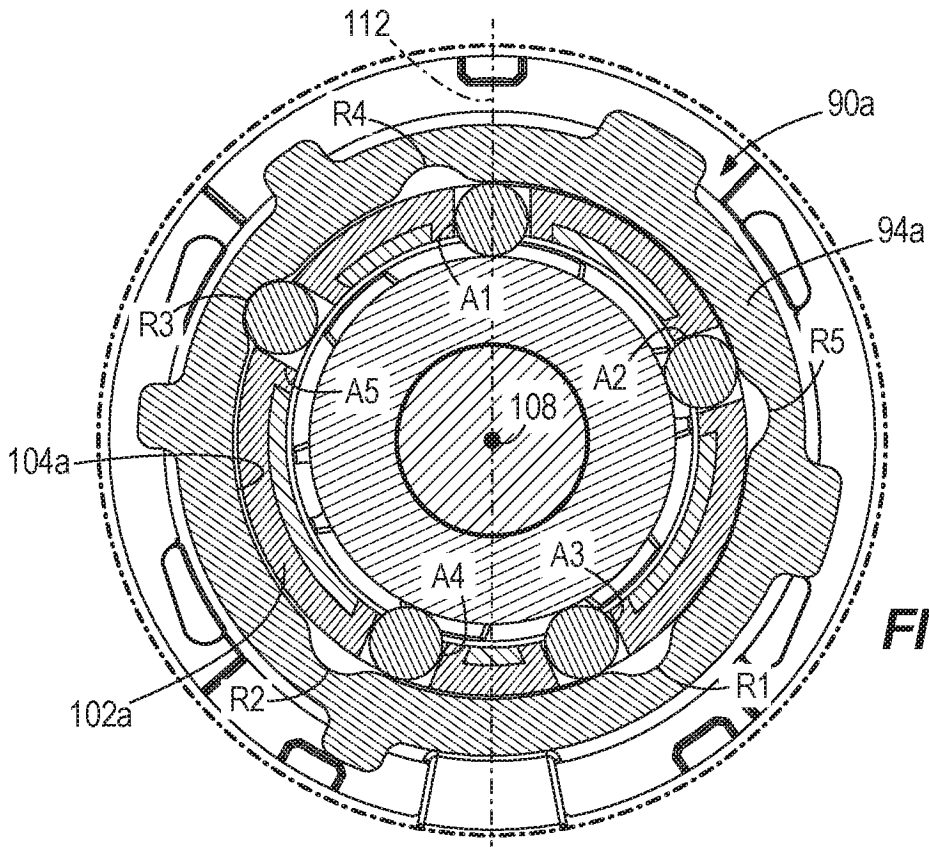

FIG. 36

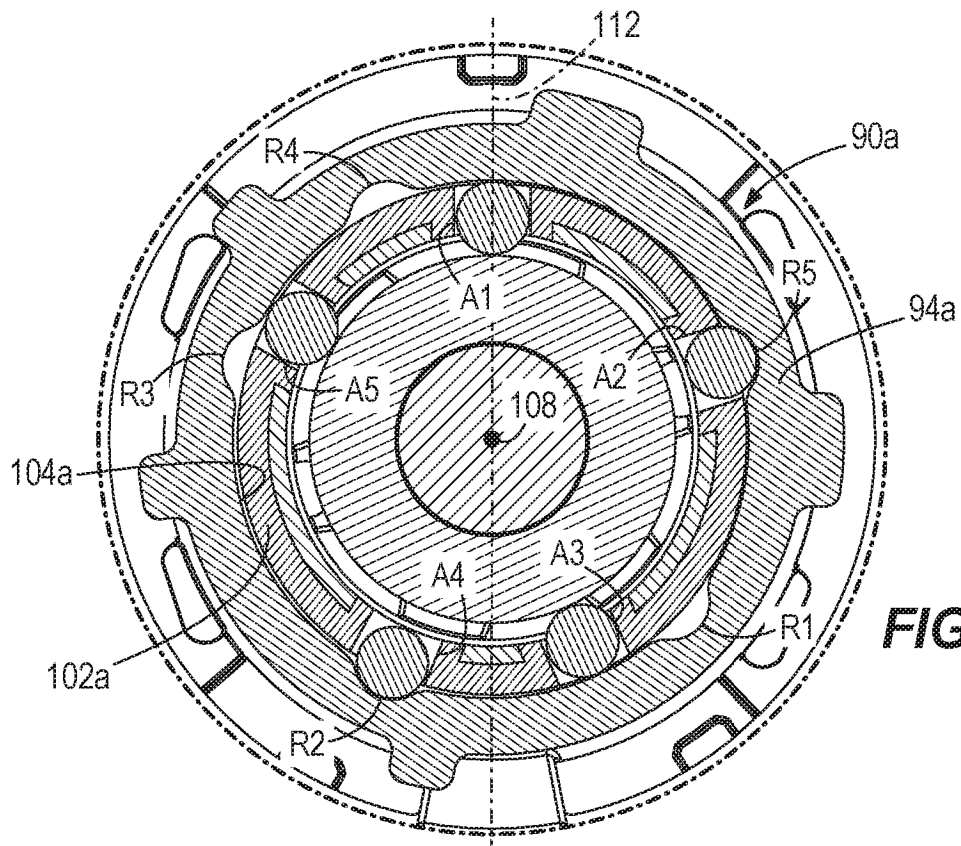

FIG. 37

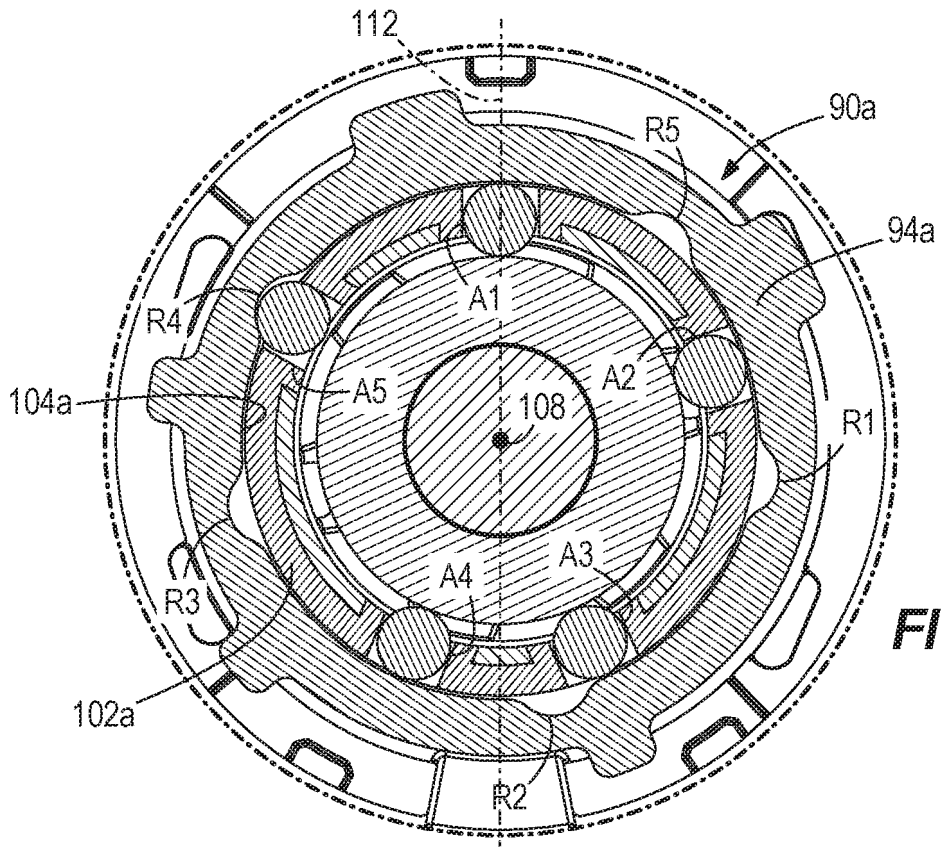

FIG. 38

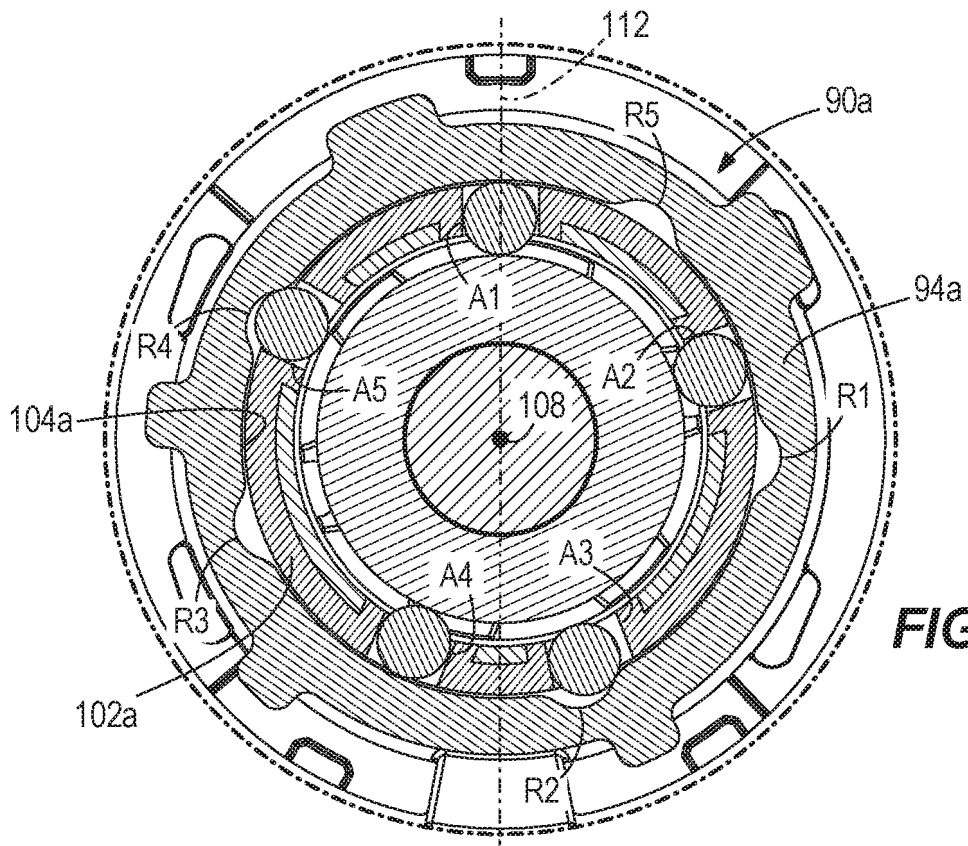

FIG. 39

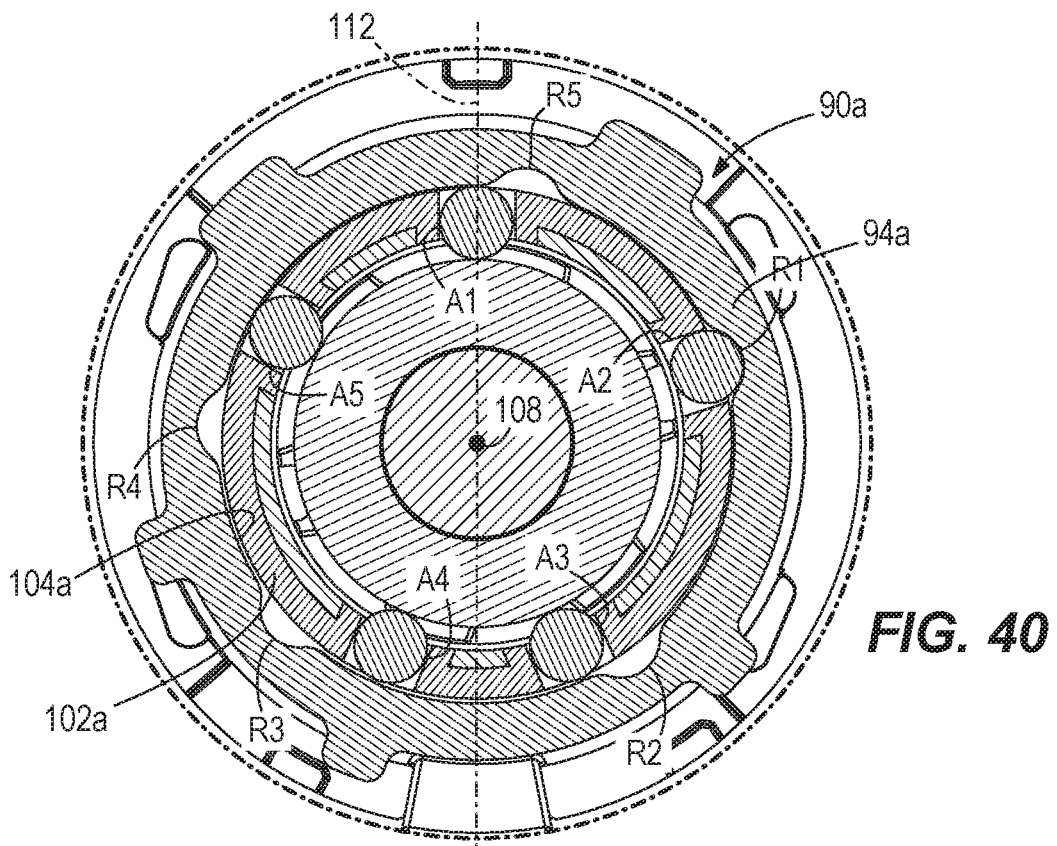

FIG. 40

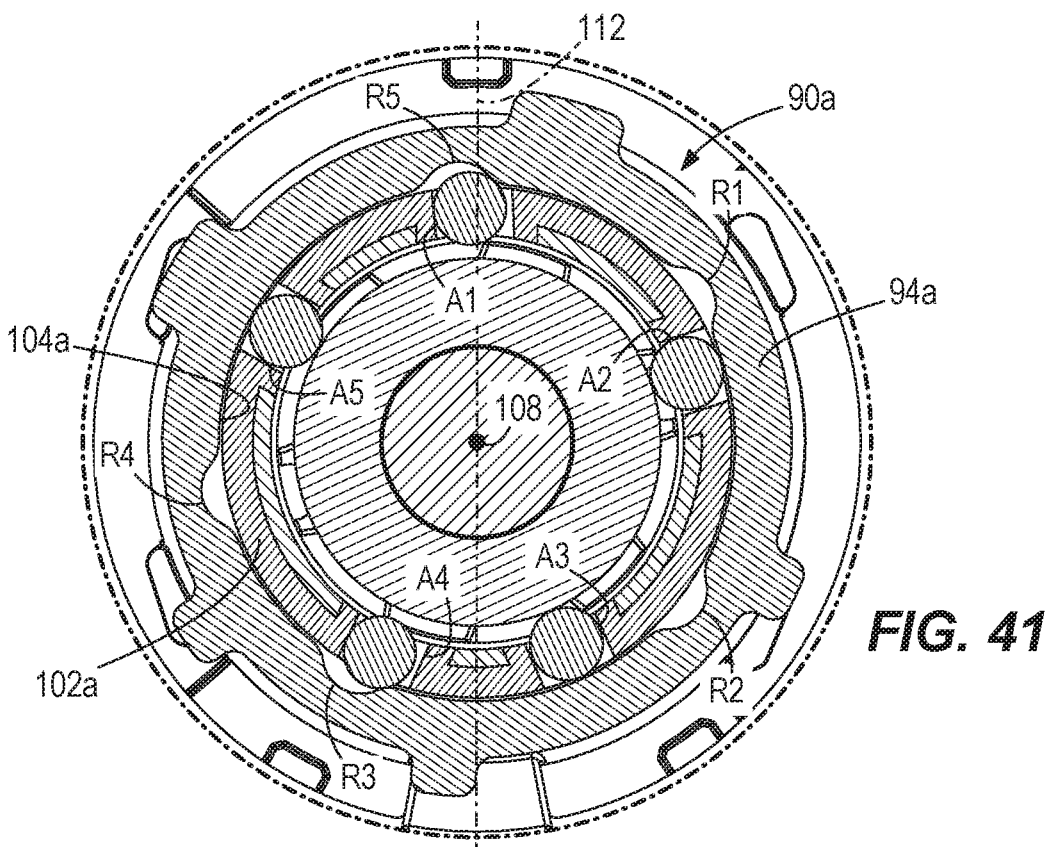

FIG. 41

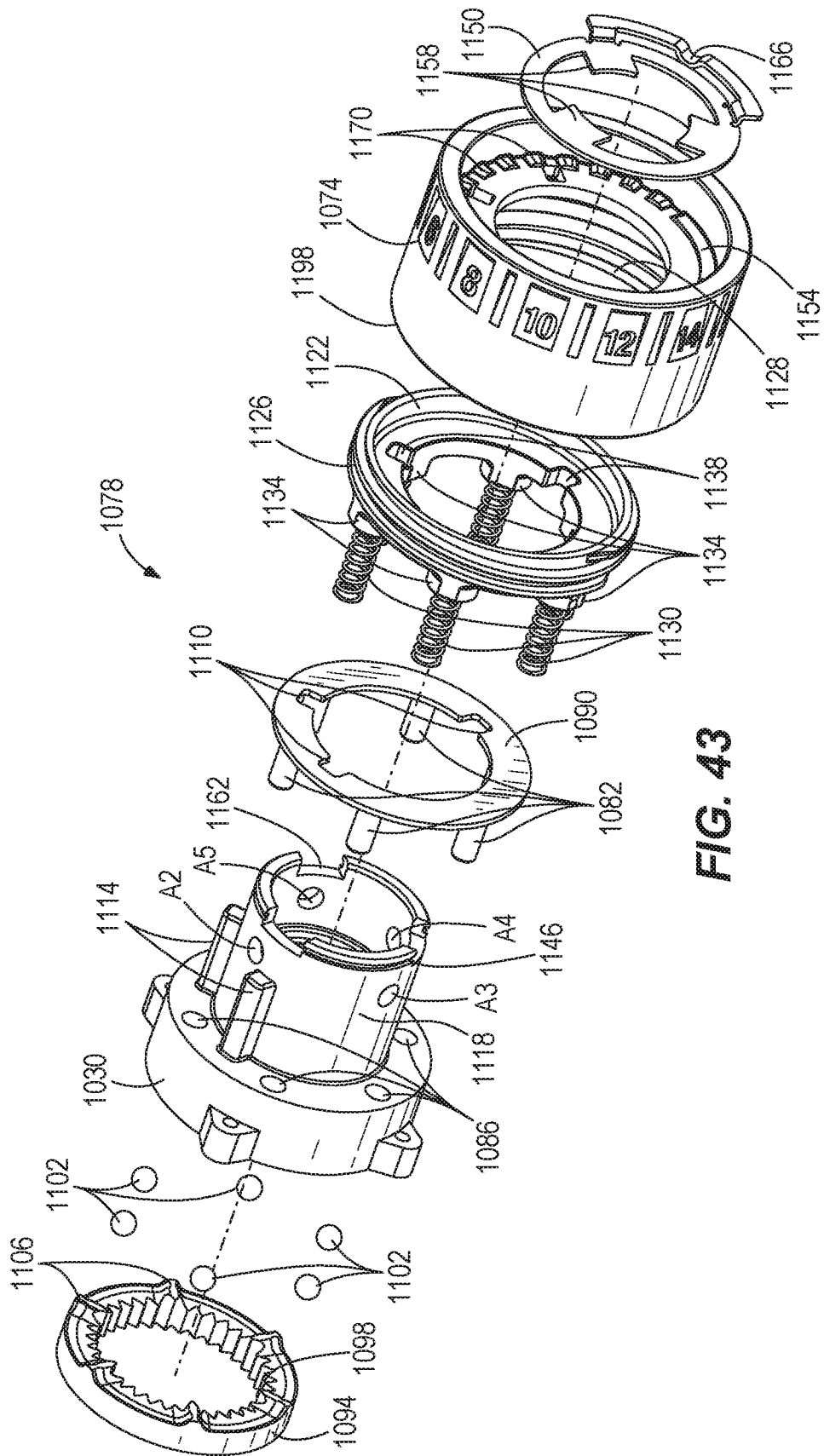

FIG. 43

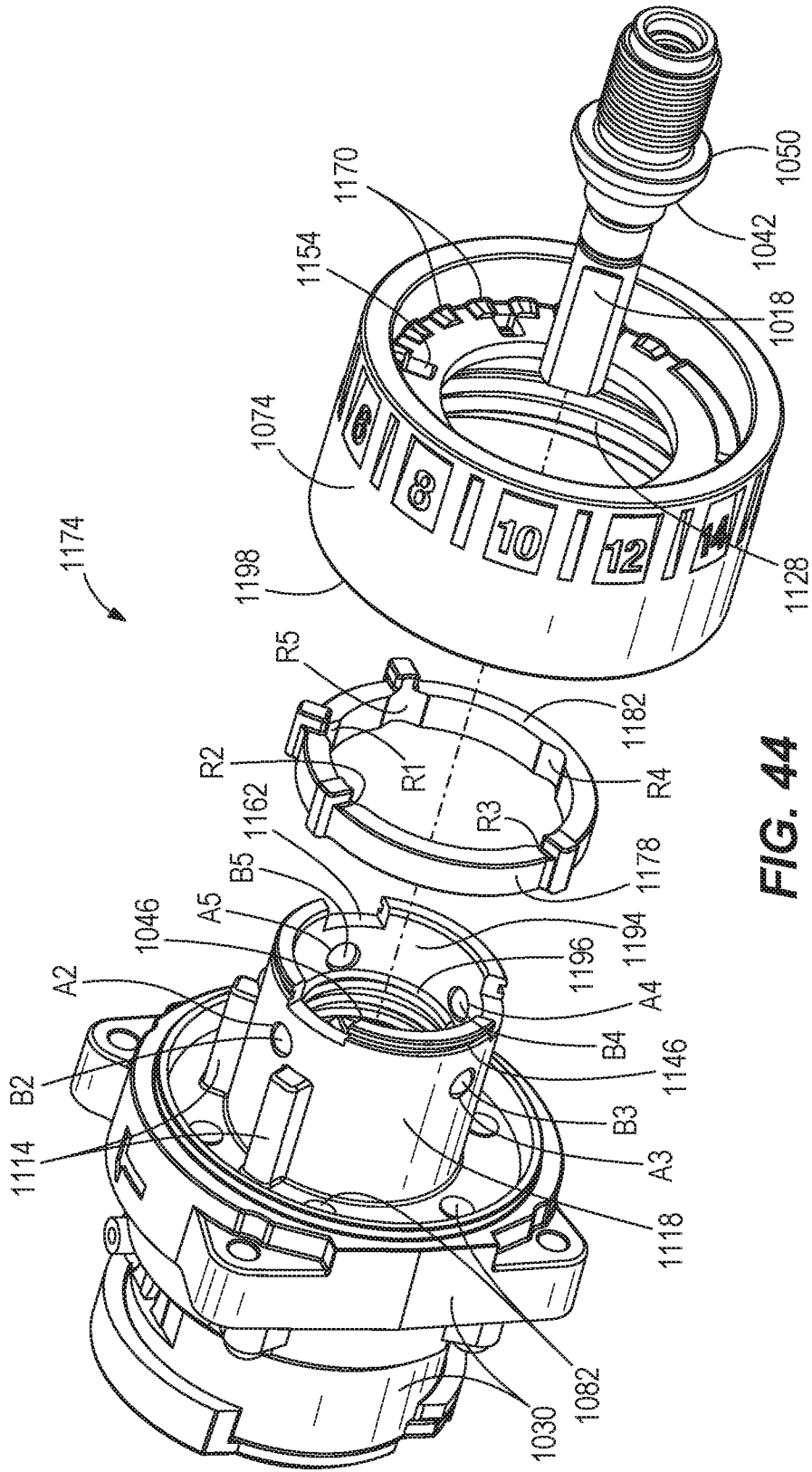

FIG. 44

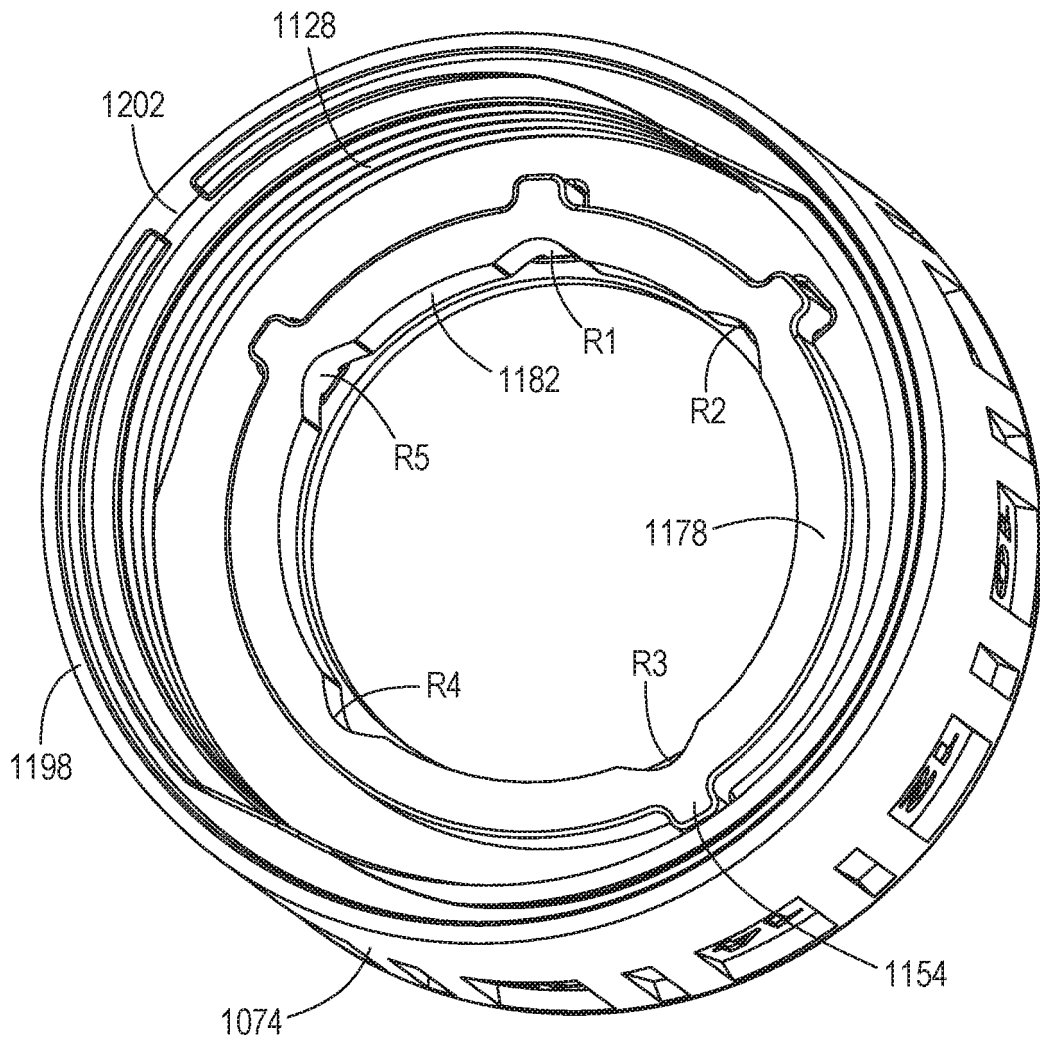
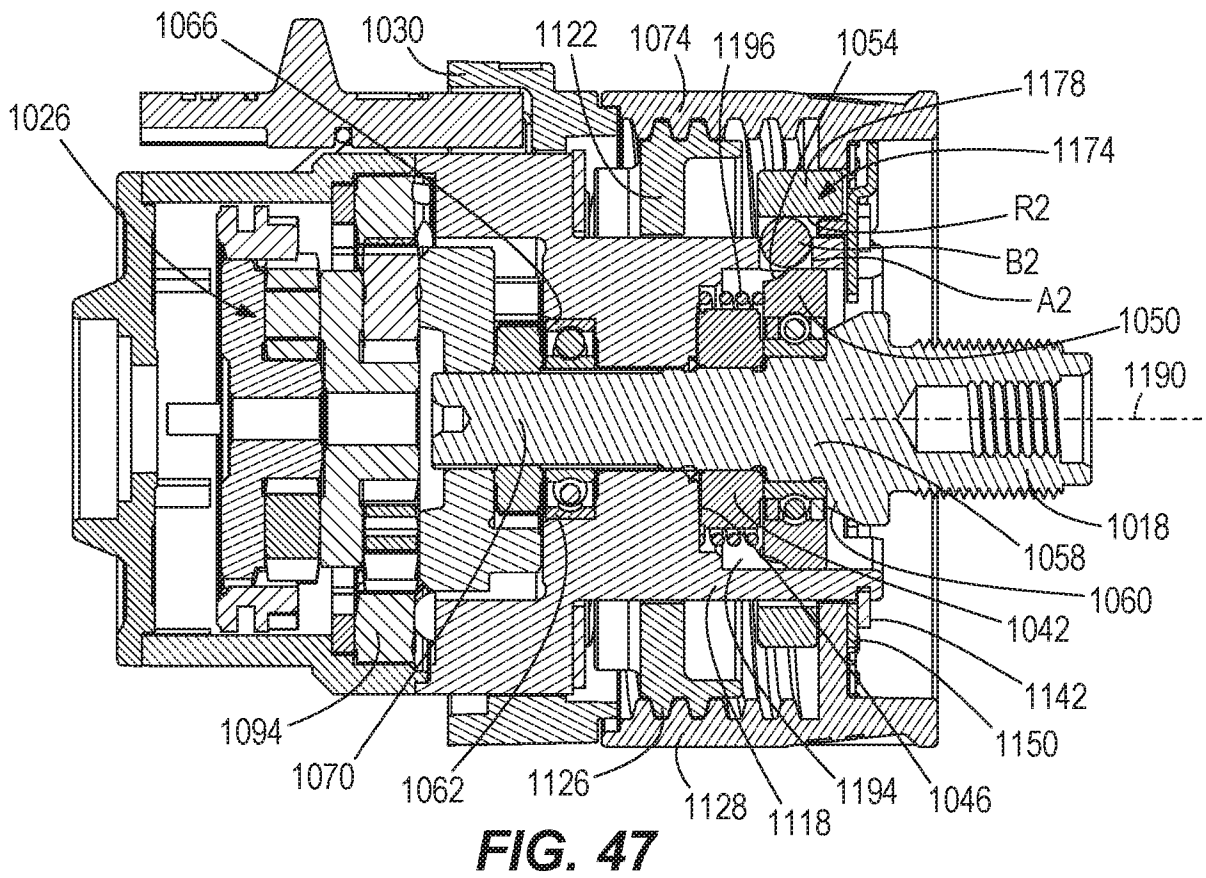
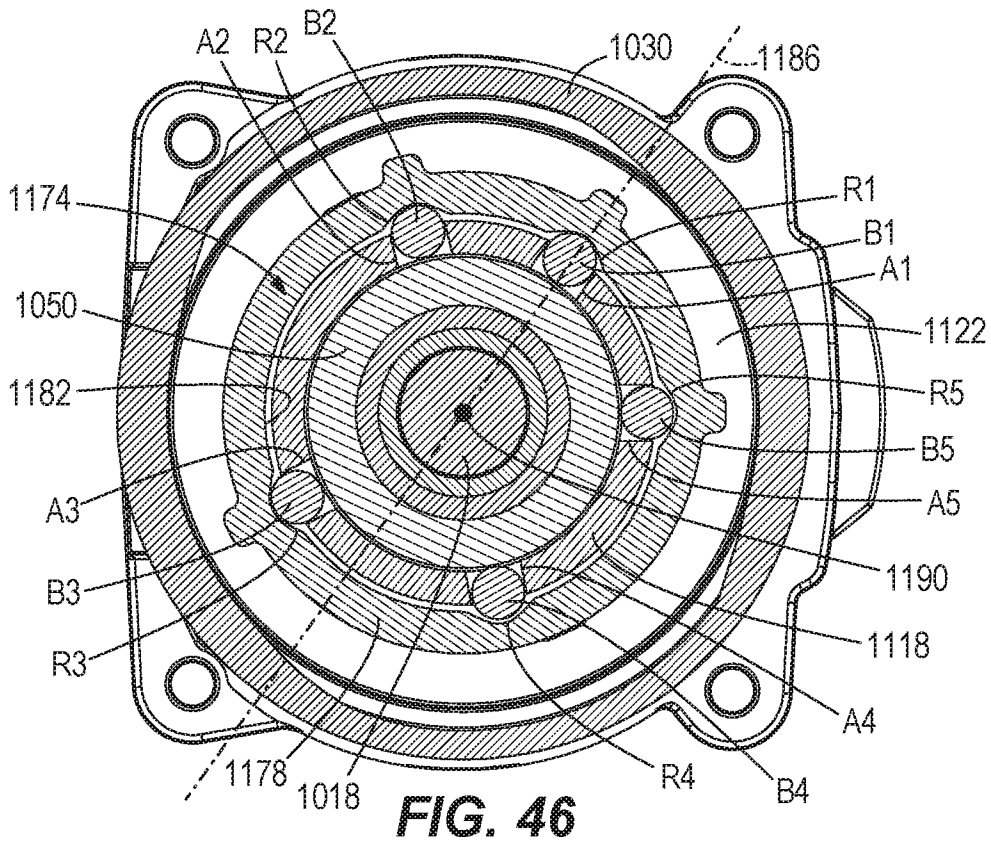

FIG. 45



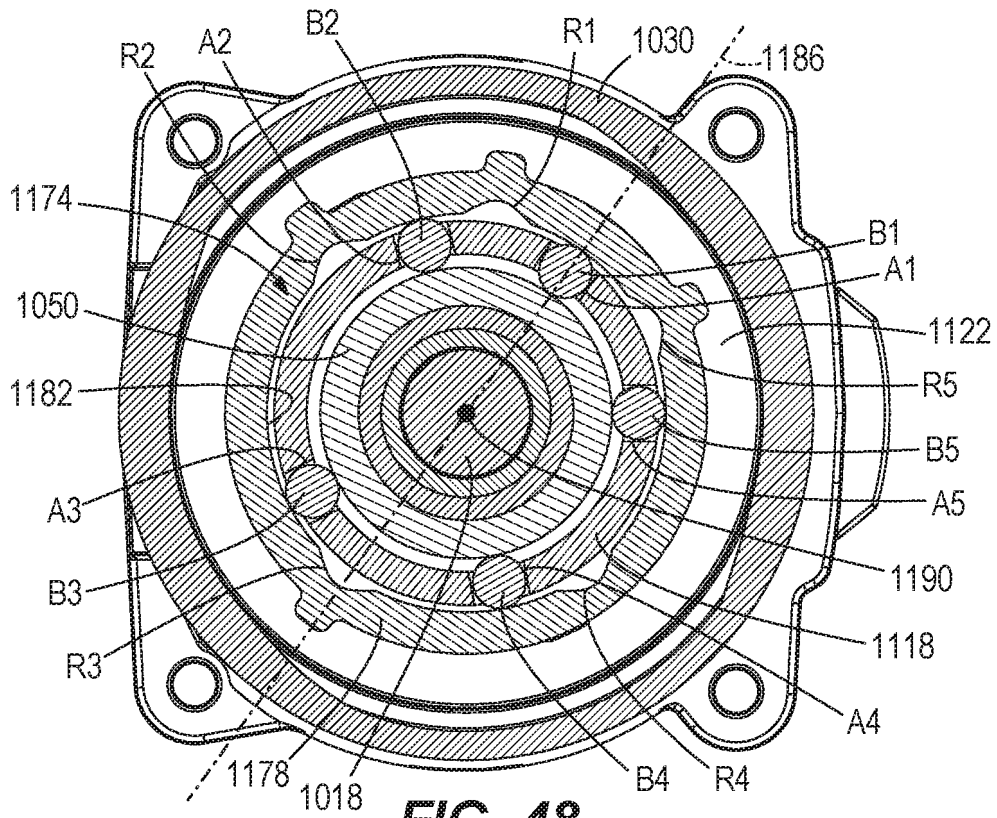

FIG. 48

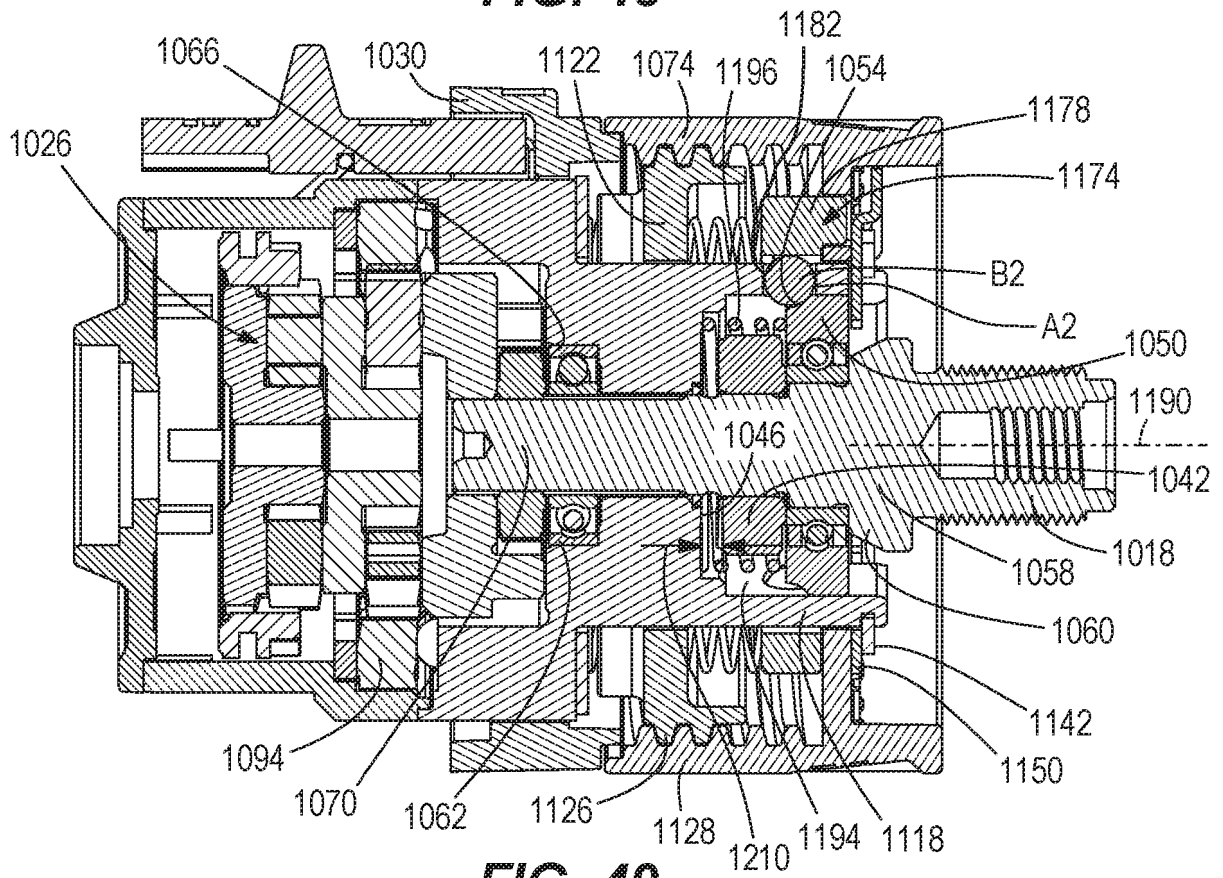

FIG. 49

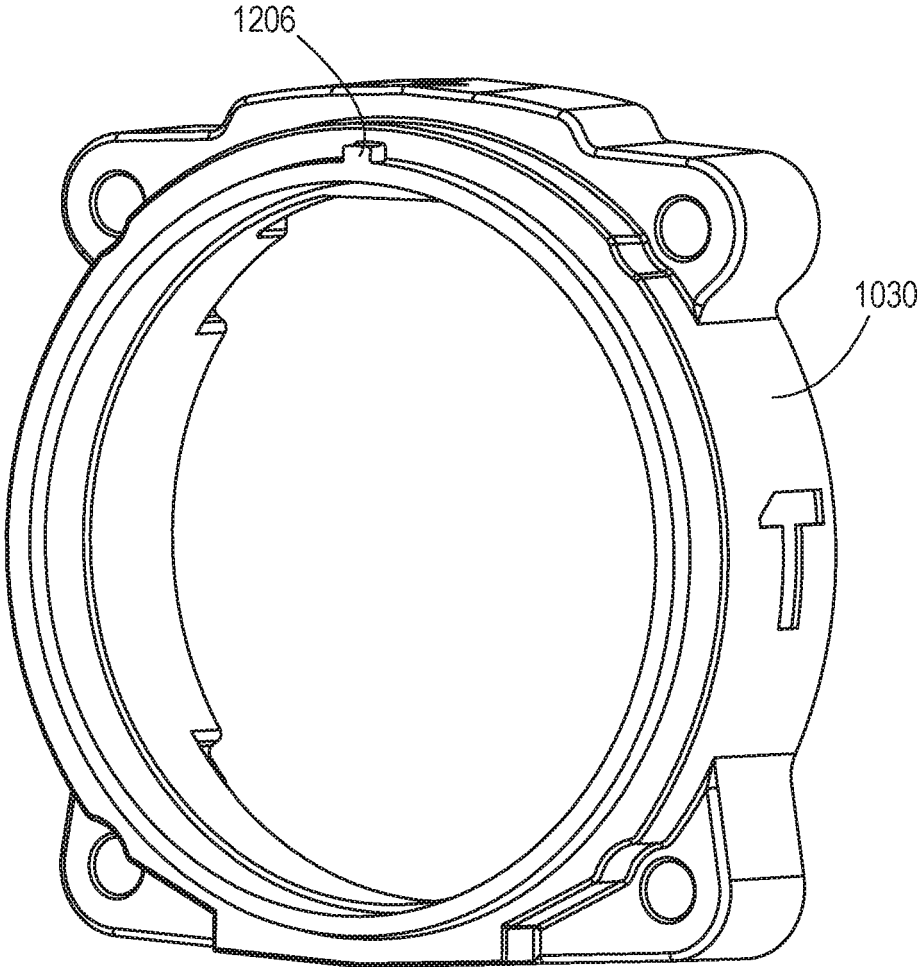

FIG. 50

REFERENCES CITED IN THE DESCRIPTION

This list of references cited by the applicant is for the reader's convenience only. It does not form part of the European patent document. Even though great care has been taken in compiling the references, errors or omissions cannot be excluded and the EPO disclaims all liability in this regard.

Patent documents cited in the description

- US 62501962 [0001]
- US 62531054 [0001]
- US 5458206 A [0002] [0004]
- US 2014110140 A1 [0005]