

*W. Thomas,
Lifting Jack.*

N^o 17,344.

Patented May 19, 1857.

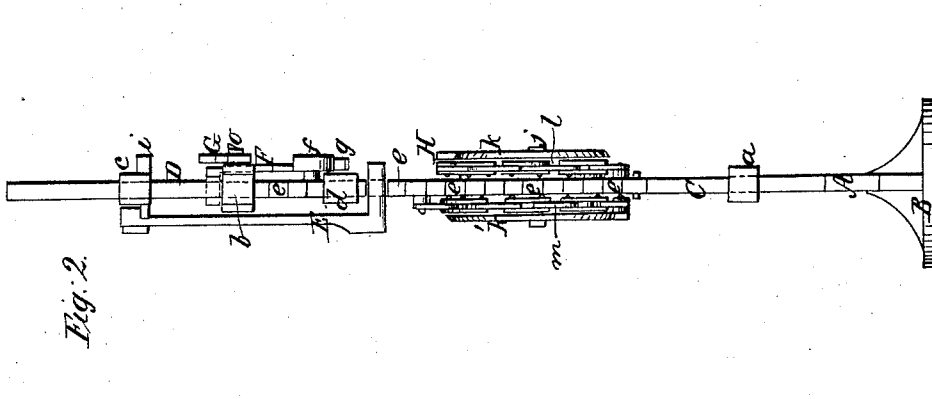

Fig. 2.

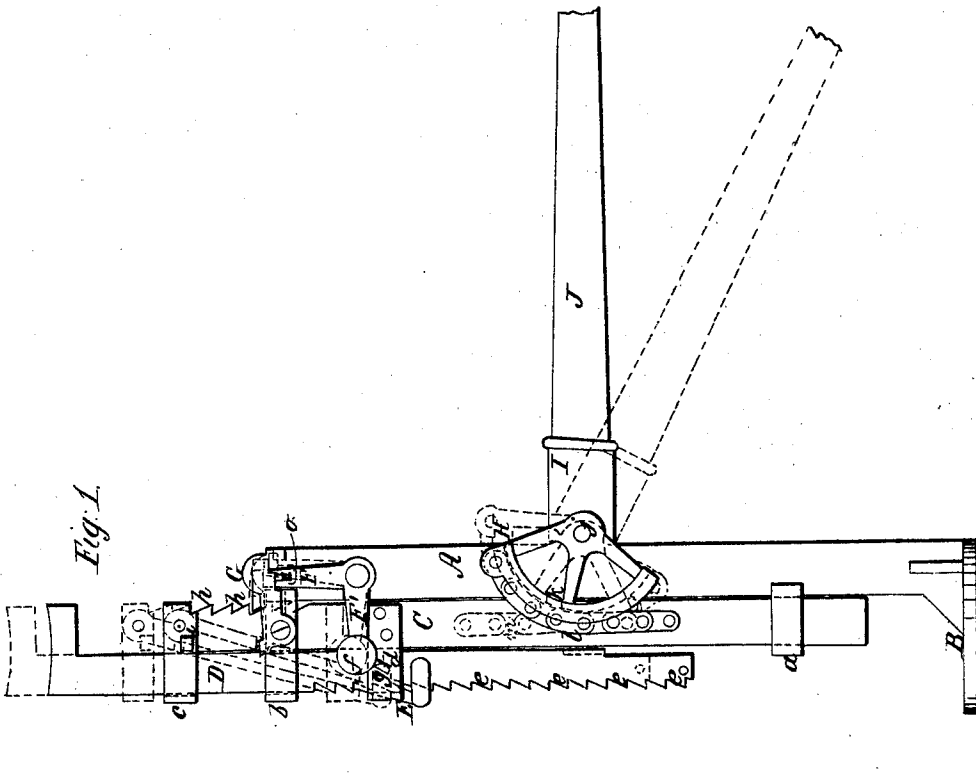

Fig. 1.

UNITED STATES PATENT OFFICE.

WILLIAM THOMAS, OF HINGHAM, MASSACHUSETTS.

LIFTING-JACK.

Specification of Letters Patent No. 17,344, dated May 19, 1857.

To all whom it may concern:

Be it known that I, WILLIAM THOMAS, of Hingham, in the county of Plymouth and State of Massachusetts, have invented a new and Improved Lifting-Jack; and I do hereby declare that the following is a full, clear, and exact description of the same, reference being had to the annexed drawings, making a part of this specification, in which—

Figure 1 is a side elevation of my improvement. Fig. 2 is a front elevation of ditto.

Similar letters of reference indicate corresponding parts in the two figures.

This invention consists in the employment or use of a pawl attached to the upright bar or standard of the implement, the pawl being so arranged as to operate automatically, or be thrown in and out from the rack of the lifting bar by the movement of said bar.

To enable those skilled in the art to fully understand and construct my invention I will proceed to describe it.

A represents an upright or standard, the lower end of which is attached to a suitable base B. The standard and base may be constructed of cast iron and cast in one piece. The standard A has a guide (a) at its lower part and a guide (b) at its upper part, the guides being cast with the standard and projecting at right angles from it.

C represents a lifting bar which is fitted and works within the guides (a)-(b). This lifting bar has two guides attached to it, one guide (c) being at its upper end, and the other guide (d) some distance below the guide (c). Within the guides (c) (d) a bar D is fitted and allowed to slide freely up and down, said bar also passing through the upper guide (b) on the standard A. The front edge of the lower part of the bar D is provided with teeth (e) of inclined or ratchet form, and a pawl E which is attached by a pivot to the upper end of the lifting bar C, catches under the teeth (e) of the bar D.

F represents a pawl the lower end of which is pivoted to the upright or standard A, the upper end of the pawl extending over the upper end of the standard. The lower end of the pawl has an arm F' projecting from it at right angles; the outer end of said arm having a knob or weight (f) on it, to which knob or weight a projection (g) is attached. The upper part of

the bar C at its back edge is provided with teeth (h) into which the pawl F catches.

To one side of the upper guide (b) of the standard A a catch G is pivoted, and to one side of the upper guide (c) a projection (i) is attached.

To the standard A, at about its center, a sector H is attached, said sector having a socket I at one side of its axis (j). This sector is formed of two parts (k), (k') a part being at each side of the standard A as shown clearly in Fig. 2. To the upper end of the part (k) of the sector, a chain (l) is attached, said chain bearing against the periphery of the part (k) and having its lower end attached to the bar C, at a point below the axis (j) of the sector, and to the lower end of the part (k') of the sector a chain (m) is attached, said chain being attached to the bar C at a point above the axis (j) of the sector.

J is a handle or lever which is fitted within the socket I.

The operation is as follows: The standard A is placed underneath the article to be raised, and the bar D is raised by moving the pawl E outward so that it will be free from the teeth (e) of the bar D, the upper end of the bar D being placed against the article to be raised—the bar D, when properly adjusted, being retained in proper position by the pawl E. The lever J is then depressed and the chain (l) forces up the bars C, D, and raises the article which rests upon the upper end of the bar D, the bars C, D, being retained by the pawl F which catches underneath the teeth (h), said pawl sustaining the bars at any point within the distance of their movement or stroke, the pawl F being kept underneath the teeth (h) by the weight (f) at the end of the arm F'. When however the bars have reached their culminating point, they are allowed to descend by having the pawl F thrown out from the teeth (h) in consequence of the lower end of the pawl E striking against the projection (g) on the weight (f), the pawl E being kept out from the teeth (h) by the catch G which drops over a projection (o) on the pawl F. When the bars reach their lowest point, the projection (i) on the guide (c) strikes against the inner end of the catch G and throws the outer end of said catch upward and free from the pawl E which is consequently made to fall in gear with the teeth (h) by the weighted arm F'.

Thus it will be seen that the pawl F has an automatic movement, that is the jack is operated entirely by the lever J, the lifting bars being raised by the lever J and the pawl F operated by the movement of the bars. In order therefore to lower the bars and let down the weight or article previously raised, all that is required is, merely, to depress the end of the lever J, till the lower end of the pawl E strikes against the projection (g).

By having the extension bar D attached to the bar C as shown the implement may be readily adjusted to raise articles of varying heights, and the trouble of "blocking up" the standard which is now necessary in raising ordinary jacks is avoided.

By lifting the bars C, D, by means of the sector H and chains (l) (m) an even or nearly even power is applied to the bars at

all points of their movement. The chain (l) raises the bars and the chain (m) draws them down.

The jack may be cheaply constructed. It is very simple, there are no parts liable to get out of repair, and it may be applied and operated with much greater facility than the jacks of usual construction.

Having thus described my invention what I claim as new and desire to secure by Letters Patent is—

The retaining pawl F, provided with the weighted arm F', attached to the standard A, arranged relatively with the pawl E, and catch G, substantially as shown, for the purpose set forth.

WILLIAM THOMAS.

Witnesses:

WILLIAM THOMAS, Jr.,
CALEB B. MARSH.