



(86) Date de dépôt PCT/PCT Filing Date: 2001/07/03
 (87) Date publication PCT/PCT Publication Date: 2002/01/24
 (45) Date de délivrance/Issue Date: 2009/03/17
 (85) Entrée phase nationale/National Entry: 2003/01/07
 (86) N° demande PCT/PCT Application No.: US 2001/021296
 (87) N° publication PCT/PCT Publication No.: 2002/006047
 (30) Priorité/Priority: 2000/07/13 (US60/217,918)

(51) Cl.Int./Int.Cl. *B29C 47/20* (2006.01),
B29C 47/06 (2006.01), *B29C 47/58* (2006.01),
B29C 47/70 (2006.01)
 (72) Inventeurs/Inventors:
 DOOLEY, JOSEPH, US;
 JENKINS, STEVEN R., US;
 NAUMOVITZ, JOHN A., US
 (73) Propriétaire/Owner:
 DOW GLOBAL TECHNOLOGIES INC., US
 (74) Agent: SMART & BIGGAR

(54) Titre : FILMS MULTICOUCHES TUBULAIRES, ET PROCEDE ET APPAREIL POUR LA REALISATION DE TELS FILMS

(54) Title: TUBULAR MULTILAYER FILMS, METHOD AND APPARATUS FOR PREPARING THE SAME

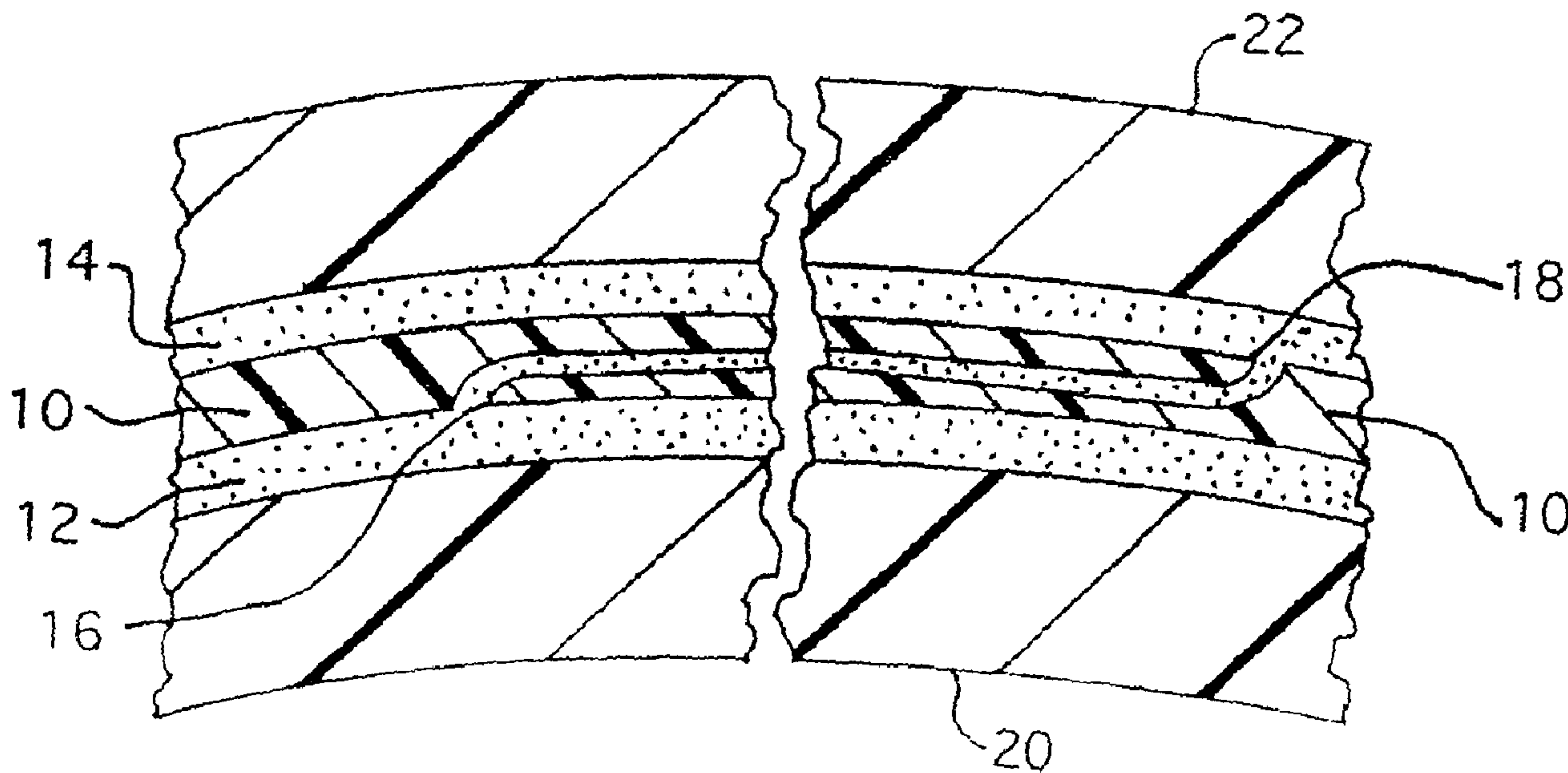

(57) Abrégé/Abstract:

A tubular, multilayer film comprises a central barrier layer and a pair of adhesive layers on opposite sides of the central barrier layer. The adhesive layers completely cover the central barrier layer. Opposing edges of the central barrier layer overlap longitudinally along the tubular, multilayer film. The total thickness of the central barrier layers in the overlapping portion is substantially the same as the thickness of the central barrier layer in the non-overlapping portion. The tubular, multilayer film also includes inner and outer surface layers. The inner surface layer extends completely around the interior of the tubular, multilayer film, and the outer surface layer extends completely around the exterior of the tubular, multilayer film.

(12) INTERNATIONAL APPLICATION PUBLISHED UNDER THE PATENT COOPERATION TREATY (PCT)

(19) World Intellectual Property Organization
International Bureau(43) International Publication Date
24 January 2002 (24.01.2002)

PCT

(10) International Publication Number
WO 02/06047 A3

- (51) International Patent Classification⁷: B32B 1/08, B29C 47/06, F16L 11/04, B32B 31/30
- (21) International Application Number: PCT/US01/21296
- (22) International Filing Date: 3 July 2001 (03.07.2001)
- (25) Filing Language: English
- (26) Publication Language: English
- (30) Priority Data:
60/217,918 13 July 2000 (13.07.2000) US
- (71) Applicant: THE DOW CHEMICAL COMPANY
[US/US]; 2030 Dow Center, Midland, MI 48674 (US).
- (72) Inventors: DOOLEY, Joseph; 3645 East Hubbard Road, Midland, MI 48642 (US). JENKINS, Steven, R.; 576 Point Drive, Clare, MI 48617 (US). NAUMOVITZ, John, A.; 4780 Southfield Road, Auburn, MI 48611 (US).
- (74) Agent: DAMOCLES, Nemia, C.; The Dow Chemical Company, Intellectual Property, P.O. Box 1967, Midland, MI 48641-1967 (US).
- (81) Designated States (*national*): AE, AG, AL, AM, AT, AU, AZ, BA, BB, BG, BR, BY, BZ, CA, CH, CN, CO, CR, CZ, DE, DK, DM, DZ, EC, EE, ES, FI, GB, GD, GE, GH, GM, HR, HU, ID, IL, IN, IS, JP, KE, KG, KR, KZ, LC, LK, LR, LS, LT, LU, LV, MA, MD, MG, MK, MN, MW, MX, MZ, NO, NZ, PL, PT, RO, RU, SD, SE, SG, SI, SK, SL, TJ, TM, TR, TT, TZ, UA, UG, UZ, YU, ZA, ZW.
- (84) Designated States (*regional*): ARIPO patent (GH, GM, KE, LS, MW, MZ, SD, SL, SZ, TZ, UG, ZW), Eurasian patent (AM, AZ, BY, KG, KZ, MD, RU, TJ, TM), European patent (AT, BE, CH, CY, DE, DK, ES, FI, FR, GB, GR, IE, IT, LU, MC, NL, PT, SE, TR), OAPI patent (BF, BJ, CF, CG, CI, CM, GA, GN, GW, ML, MR, NE, SN, TD, TG).
- Published:**
— with international search report
— before the expiration of the time limit for amending the claims and to be republished in the event of receipt of amendments
- (88) Date of publication of the international search report:
13 June 2002

[Continued on next page]

(54) Title: TUBULAR MULTILAYER FILMS, METHOD AND APPARATUS FOR PREPARING THE SAME

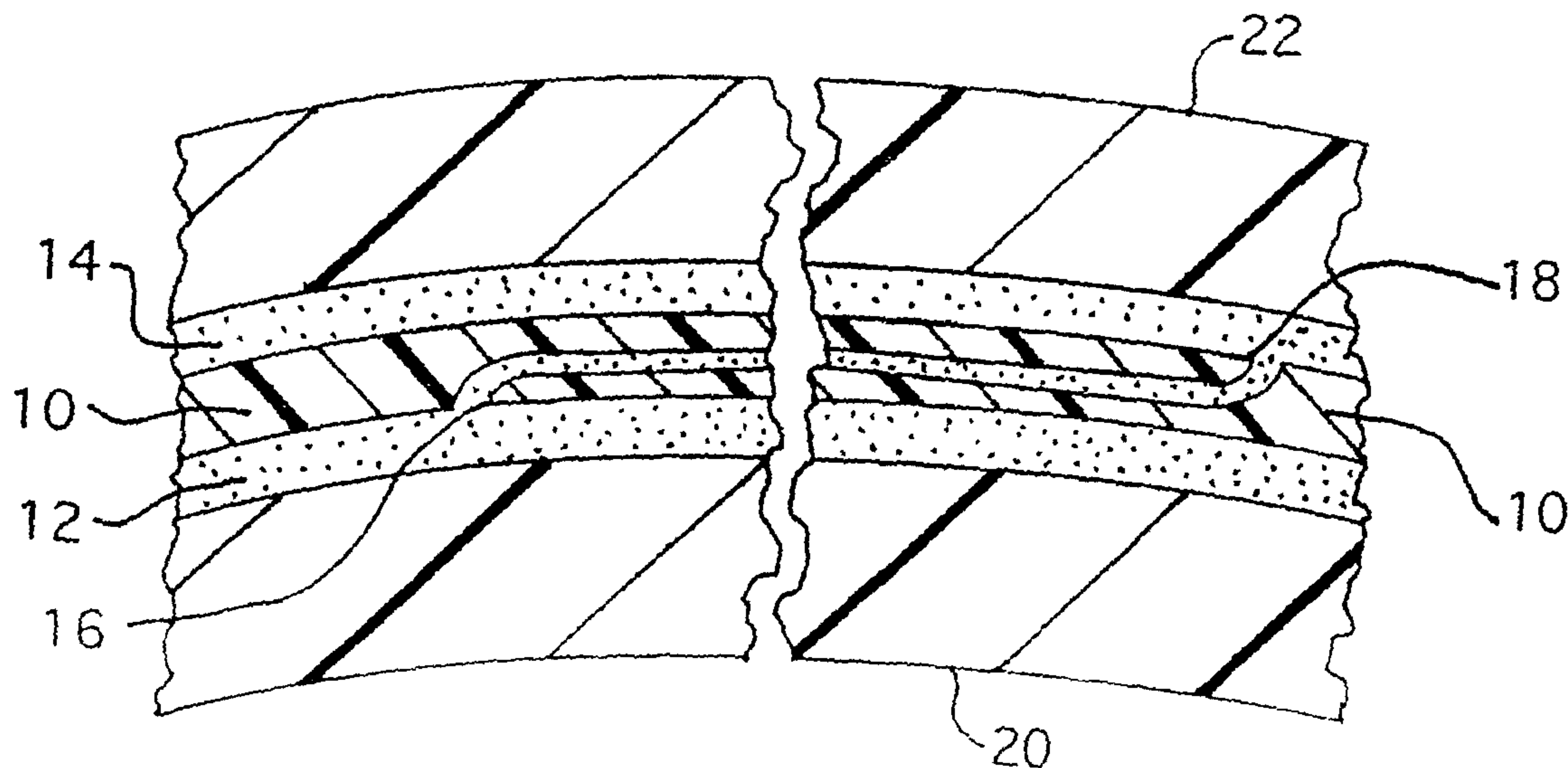

(57) Abstract: A tubular, multilayer film comprises a central barrier layer and a pair of adhesive layers on opposite sides of the central barrier layer. The adhesive layers completely cover the central barrier layer. Opposing edges of the central barrier layer overlap longitudinally along the tubular, multilayer film. The total thickness of the central barrier layers in the overlapping portion is substantially the same as the thickness of the central barrier layer in the non-overlapping portion. The tubular, multilayer film also includes inner and outer surface layers. The inner surface layer extends completely around the interior of the tubular, multilayer film, and the outer surface layer extends completely around the exterior of the tubular, multilayer film.

WO 02/06047 A3

TUBULAR MULTILAYER FILMS, METHOD AND APPARATUS FOR
PREPARING THE SAME

The present invention relates generally to multilayer, tubular films and to methods and apparatus for making such films. More particularly, the invention relates to
5 tubular, polymer films containing a barrier layer and having uniform barrier properties around the circumference of the tube.

Film structures including a barrier layer such as polyvinylidene chloride have been difficult to extrude in tubular form. Extrusion of polyvinylidene chloride presents special problems. One problem results from the thermal degradation of the polymer which
10 can occur in the extrusion die. To overcome this, polyvinylidene chloride has been encapsulated in an encapsulating material which does not exhibit the thermal degradation of polyvinylidene chloride.

Another problem which arises in the formation of polyvinylidene chloride into a tubular film is the seam which is formed. The seam extends along a weld line on one
15 side of the extrudate. Generally, the extrusion die used to produce a tubular extrudate defines an annular chamber into which the extrusion material is forced. The material separates into two substreams which flow in opposite directions around the annular chamber, meeting on the opposite side of the chamber where they recombine. The streams then exit from the annular opening, and define a weld line at the point of recombination.

If an encapsulated layer of a barrier material such as polyvinylidene chloride
20 is extruded in this way, the polyvinylidene chloride core does not recombine along the weld line. Only the encapsulating material recombines at the weld line. Since the encapsulating material has a much higher gas transmission rate than polyvinylidene chloride, the tubular film has higher gas transmission properties at the weld line than in the rest of the tubular
25 film. This is unacceptable in many applications.

U.S. Patent No. 4,643,927, to Luecke et al., suggests one solution to this problem. Luecke discloses a multilayer film having a central layer of barrier material which overlaps itself by a substantial distance along the weld line. The patent states that an overlap of two thirds of one inch in the barrier layer along the weld line is sufficient to

50431-6(S)

provide a film in which the oxygen transmission rate along the weld line is no greater than in other portion of the film.

While Luecke represents a significant improvement in the manufacture of tubular barrier films, problems still remain. Blown films containing polyvinylidene chloride can only be produced on small dies (those having a diameter of less than about 8 inches (20 cm)).

Furthermore, even these small blown film dies can only be operated for about 1 to 4 weeks before the line must be shut down and cleaned. Because of its thermal degradability, polyvinylidene chloride has a tendency to "carbonize" in the extrusion equipment. Carbonization results in the formation of small carbon particles in the molten extrudate. Blown film dies have a large surface area where the molten polymer is exposed to long residence time, and polyvinylidene chloride has a tendency to adhere to the metal. The long residence time results in degradation of the polyvinylidene chloride. Black, degraded polymer may form, which can then break loose and contaminate the film. This is an even bigger problem on large dies (those having a diameter of greater than about 8 inches (20 cm)) due to the increased surface area and higher metal temperature as a result of higher temperature skin polymers conducting heat to the die mandrel. The carbon build-up requires the manufacturer to shut down and clean the extrusion apparatus. The shutdown and cleaning of the extrusion apparatus results in high maintenance costs and lost production time.

Thus, it would be desirable to make a coextruded blown film containing a barrier material, to produce such a film on large dies, and to operate for long periods of time without shutdowns due to carbon formation.

These needs are met by the tubular, multilayer film, methods and apparatus of embodiments of the present invention. The tubular, multilayer film includes a central barrier layer and a pair of adhesive layers on opposite sides of the central barrier layer. The adhesive layers completely cover the central barrier layer. Opposing edges of the central barrier layer overlap longitudinally along the tubular, multilayer film. The total thickness of the central barrier layers in the overlapping portion is substantially the same as the thickness of the central barrier layer in the non-overlapping portion. The tubular, multilayer film also

50431-6 (S)

includes inner and outer surface layers. The inner surface layer extends completely around the interior of the tubular, multilayer film, and the outer surface layer extends completely around the exterior of the tubular, multilayer film. This arrangement covers the encapsulated barrier layer and protects it from degradation. Additional layers may be
5 included as needed.

Some embodiments of the invention also involve a tubular film including a central barrier layer overlapping by at least an amount determined by Equation 1 along a weld line which extends longitudinally along the tubular film. The central barrier layer has substantially the same total thickness in the overlapping portion as in the non-overlapping portion. An inner
10 adhesive layer and an outer adhesive layer are positioned on opposite sides of the central barrier layer. The adhesive layers completely encapsulate the central barrier layer. An inner surface layer is positioned inside the inner adhesive layer, and an outer surface layer is positioned outside the outer adhesive layer.

The central barrier layer might be made from a polymer selected from
15 vinylidene chloride polymers and copolymers, ethylene vinyl alcohol polymers and copolymers, polyamide (Nylon) polymers and copolymers, and acrylonitrile polymers and copolymers. The adhesive layers might be made from a polymer selected from ethylene vinyl acetate (EVA) polymers and copolymers, ethylene methyl acrylate (EMA) polymers and copolymers, ethylene acrylic acid (EAA) polymers and copolymers, ionomers,
20 and maleic anhydride grafted olefin polymers and copolymers. The surface layers might be made from a polymer selected from polyethylene polymers and copolymers, nylon and K-resins (styrene/butadiene block copolymers), ethylene vinyl acetate copolymer (EVA), polypropylene (PP) and polyethylene terephthalate (PET).

50431-6(S)

According to one aspect of the present invention, there is provided an extrusion apparatus for coextruding a multilayer film from a plurality of feed-stock materials comprising: a core extruder for extruding a core extrudate; 5 a preencapsulation die disposed adjacent the outlet of the core extruder; the preencapsulation die having a gap in the dieland area with different thicknesses around its circumference for producing a non-uniform encapsulation layer thickness; a preencapsular extruder for extruding a 10 preencapsular extrudate; a preencapsular transfer tube for transferring the preencapsular extrudate to the preencapsulation die where the preencapsular extrudate surrounds the core extrudate to form a preencapsulated core extrudate; a coextrusion die having a distribution manifold 15 comprising a body having an inlet end and an outlet end, a manifold inlet near the inlet end of the body, and a pair of manifold channels extending from the manifold inlet around the body in opposite directions, opposite ends of the manifold channels overlapping each other such that the 20 preencapsulated core extrudate in the overlapping ends of the manifold channels remains separated; and a preencapsulated core extrudate transfer tube disposed downstream of the preencapsulation die for transferring the preencapsulated core extrudate to the coextrusion die.

25 Another aspect of the present invention also includes a method of making a tubular, multilayer film. The method includes extruding a block of material having a barrier core and an adhesive covering the barrier layer core into a first stream having a generally annular 30 cross-section. The first stream has a central barrier layer which overlaps longitudinally along the tubular, multilayer film, such that the total thickness of the central barrier layers in the overlapping portion is substantially the same

50431-6(S)

as the thickness of the central barrier layer in the non-overlapping portion. An inner surface layer is extruded into a second stream having a generally annular cross-section. The second stream is positioned within the first stream and is joined thereto by the adhesive. An outer surface layer is extruded into a third stream having a generally annular cross-section. The third stream is positioned to surround the first stream and is joined thereto by the adhesive. The first stream might be extruded such that the opposing longitudinally extending edges of the central barrier layer overlap.

Another aspect of the present invention relates to a method for coextruding a multilayer tubular film having a barrier material. A core extrudate of barrier material is extruded with a core extruder. A preencapsular extrudate of preencapsular material is extruded and directed to a preencapsulation die provided adjacent to the outlet of the core extruder. The preencapsulation die is capable of producing a non-uniform layer thickness. The core extrudate and the preencapsular extrudate are joined in the preencapsulation die in a coaxial relationship wherein the preencapsular extrudate is disposed radially outwardly of the core extrudate to form a preencapsulated core extrudate having a non-uniform layer thickness. An inner layer extrudate and an outer layer extrudate are extruded. The preencapsulated core extrudate is fed through a distribution manifold to a coextrusion die. The distribution manifold is designed to overlap opposing longitudinally extending edges. A multilayer blown film having the inner layer extrudate disposed radially inwardly of the preencapsulated core extrudate and the outer layer extrudate disposed radially outwardly of the preencapsulated core extrudate is formed.

50431-6(S)

The coextrusion die has an annular channel adjacent to the distribution manifold to receive the preencapsulated core extrudate from the manifold channels. The depth of the annular channel is such that the flow of the polymer is not excessively restricted, and is approximately twice the depth of the end of one manifold channel in one embodiment.

The preencapsulation die might produce a preencapsulated core extrudate having non-uniform layer thicknesses. The preencapsulation die has a first die gap and a second die gap, the first die gap being greater than the second die gap so that more polymer flows through the first die gap than through the second die gap in one embodiment.

The inner layer extrudate and the outer layer extrudate can be joined to the preencapsulated core extrudate either before or after the preencapsulated core extrudate is fed through the coextrusion die. Additional inner layers and outer layers can be included, if desired.

Another aspect of the invention is an extrusion apparatus for coextruding a multilayer film from a plurality of feed stock materials. The apparatus includes a core extruder for extruding a core extrudate, and a preencapsular extruder for extruding a

preencapsular extrudate. A preencapsular transfer tube transfers the preencapsular extrudate to the preencapsulation die, which is disposed adjacent the outlet of the core extruder. A preencapsulated core extrudate transfer tube disposed downstream of the preencapsulation die transfers the preencapsulated core extrudate to the coextrusion die, which has a
5 distribution manifold.

Another aspect of the invention is the distribution manifold. The distribution manifold includes a body having an inlet end and an outlet end, a manifold inlet at the inlet end of the body, and a pair of manifold channels. The pair of manifold channels has substantially the same length and extends from the manifold inlet around the body in
10 opposite directions. Opposite ends of the manifold channels overlap each other by a set distance at a point opposite the manifold inlet. The opposite ends of the manifold channels are at different radial distances from the center of the body such that the preencapsulated core extrudate in the overlapping ends of the manifold channels remains separated. If the geometry is planar, the ends of the manifold channel will be at the same radial distance.
15 The manifold channels decrease in the cross-sectional area from the manifold inlet to the opposite end. The manifold channels preferably have a streamlined shape, preferably a teardrop shape. The manifold channels preferably have an aspect ratio of height to depth of greater than 3:1. The distribution manifold preferably has a depression in the body located where the manifold channels overlap. The depression is at a first radial distance from the
20 center of the body, and the set distance of the end of one manifold channel is located in the depression. There is an insert positioned over the depression. The insert is at a second radial distance from the center of the body, the second radial distance being greater than the first. The set distance of the end of the second manifold channel is located on the insert. The depression and the insert define a gap therebetween so that the preencapsulated core
25 extrudate from the end of the manifold channel located in the depression flows through the gap.

Another aspect of the invention is a preencapsulation die for preencapsulating thermally sensitive polymer. The preencapsulation die includes a die body having an annular opening therethrough. The die body has a first member and a second
30 member adjacent to the first member. The preencapsulation die includes an inner mandrel which extends circumferentially around the annular opening in the first member. The inner

50431-6(S)

mandrel has a first surface and a second surface. The first surface is lower than the second surface whereby the first surface of the inner mandrel and the second member define a first die gap, and the second surface of the inner mandrel and the second member define a second die gap, the first die gap being greater than the second die gap, and whereby the preencapsulation die is capable of producing a non-uniform encapsulation layer thickness. There is also a preencapsulation distribution manifold which extends circumferentially around the inner mandrel in the first member.

The preencapsulation die optionally includes a resin distribution channel extending about 180 degrees circumferentially around the preencapsulation distribution manifold in the first member. The resin distribution channel terminates in an opening at each end in one embodiment. The openings in the resin distribution channel communicate with the preencapsulation distribution manifold. The resin distribution channel communicates with a resin inlet, which is located intermediate the openings in the resin distribution channel. The openings in the resin distribution channel are positioned adjacent the first surface of the inner mandrel in one embodiment. The inner mandrel has a pair of first surfaces and a pair of second surfaces in one embodiment. The first surfaces extend approximately 60 degrees around the annular opening, and the second surfaces extend approximately 120 degrees around the annular opening in one embodiment. The first surfaces are positioned on opposite sides of the inner mandrel adjacent to the openings in the resin distribution channel, and the second surfaces are positioned between the first surfaces on opposite sides of the inner mandrel in one embodiment.

50431-6(S)

The second member of the preencapsulation die can be flat. Alternatively, it could be a mirror image of the first member.

There is also provided an extrusion apparatus for
5 coextruding a multilayer film from a plurality of feedstock materials comprising: a core extruder for extruding a core extrudate; a preencapsulation die disposed adjacent the outlet of the core extruder, the preencapsulation die comprising: a die body having an annular opening
10 therethrough, the die body having a first member and a second member adjacent to the first member; an inner mandrel extending circumferentially around the annular opening in the first member, the inner mandrel having a first surface and a second surface, the first surface being lower than the
15 second surface whereby the first surface of the inner mandrel and the second member define a first die gap and the second surface of the inner mandrel and the second member define a second die gap, the first die gap being greater than the second die gap and whereby the preencapsulation die
20 produces a non-uniform encapsulation layer thickness; and a preencapsulation distribution manifold extending circumferentially around the inner mandrel in the first member; a preencapsular extruder for extruding a preencapsular extrudate; a preencapsular transfer tube for
25 transferring the preencapsular extrudate to the preencapsulation die; a coextrusion die having a distribution manifold designed to overlap opposing longitudinally extending edges of the preencapsular extrudate; and a preencapsulated core extrudate transfer
30 tube disposed downstream of the preencapsulation die for transferring the preencapsulated core extrudate to the coextrusion die.

50431-6(S)

Fig. 1 is a cross-section of the multilayer, tubular extrudate of an embodiment of the present invention, with the individual layer thicknesses greatly exaggerated for purposes of illustration.

5 Fig. 2 is a partial cross-section of the extrudate in the region of the weld line, greatly exaggerated.

Fig. 3 is a diagram of the overall process of an embodiment of the present invention.

10 Fig. 4 is a cross-section of one embodiment of the preencapsulation die of an embodiment of the present invention.

Fig. 5 is a plan view of one embodiment of the preencapsulation die of an embodiment of the present invention.

15 Fig. 6 is a schematic of a cross-section of the preencapsulated core extrudate having uniform layer thicknesses produced by the preencapsulation die of Fig. 5.

20 Fig. 7 is a plan view of another embodiment of the preencapsulation die of an embodiment of the present invention.

Fig. 8 is a schematic of a cross-section of the preencapsulated core extrudate having non-uniform layer thicknesses produced by the preencapsulation die of Fig. 7.

25 Fig. 9 is a plan view of one side of the distribution manifold of an embodiment of the present invention.

50431-6(S)

Fig. 10 is a plan view of the opposite side of the distribution manifold of an embodiment of the present invention with the insert installed.

Fig. 11 is a plan view of the side of the
5 distribution manifold shown in Fig. 8 without the insert installed.

Fig. 12 is a cross-section of the manifold channels in the distribution manifold.

Figs. 1 and 2 show cross-sectional views of the
10 tubular, multilayer films of an embodiment of the present invention. For purposes of clarity in illustration, the thicknesses of the layers are exaggerated with respect to the size of the tubular laminate. The film comprises a central barrier layer 10, and a pair of adhesive layers 12
15 and 14 which are positioned on opposite sides of the central barrier layer 10. The central barrier layer 10 can be any barrier polymer, including, but not limited to, vinylidene chloride polymers and copolymers, ethylene vinyl alcohol polymers and copolymers, nylon polymers and copolymers, and
20 acrylonitrile polymers and copolymers. The barrier layer is preferably a vinylidene chloride polymer or copolymer.

The adhesive layers 12 and 14 completely cover the central barrier layer 10. The adhesive layers 12 and 14 can be any one of a number of adhesives, including, but not limited to, EVA polymers and copolymers, EMA polymers and copolymers, EAA polymers and copolymers, ionomers, and maleic anhydride grafted olefin polymers and copolymers.

5 When the central barrier layer is polyvinylidene chloride, the adhesive layer is preferably an ethylene vinyl acetate polymer or copolymer.

As best seen in Fig. 2, the opposing edges of 16 and 18 of the central barrier layer 10 overlap along the weld line. The thickness of the central barrier layers 10 in the overlapping portion is substantially the same as the thickness of the central barrier layer 10 in the non-overlapping portion. As a result of this arrangement, the film exhibits a

10 substantially uniform oxygen transmission rate at all points around its circumference.

The multilayer film also includes inner and outer surface layers 20 and 22, respectively. The inner layer 20 extends completely around the interior of the tubular, multilayer film, and the outer layer 22 extends completely around the exterior of the film.

15 The surface layers 20 and 22 can be made of any suitable polymer, including, but not limited to, polyethylene polymers and copolymers, polyamide (Nylon), K-resins (styrene/butadiene block copolymers), polypropylene, ethylene vinyl acetate copolymer and polyethylene terephthalate. The surface layers are preferably polyethylene when the central barrier layer is polyvinylidene chloride. For a more complete discussion of the materials which can be

20 used for the central barrier (or core) layers, the adhesive layers, and the surface layers, see Lee, Jr. et al., United States Patent No. 3,477,099, and Gould, et al., United States Patent No. 4,842,791.

The adhesive layers 12 and 14 not only bond the central barrier layer 10 together in overlapping fashion at overlapping edges 16 and 18, but they also join inner and

25 outer surface layers 20 and 22 to central barrier layer 10.

Additional layers can be included in the multilayer film as may be required for the particular application. The film can include adhesive layers to adhere the additional layers to the film. The additional layers can be added in the coextrusion die. Alternatively, they can be added in a feedblock prior to the die. Methods of including additional layers are

well known to those of skill in the art. The number of layers in the multilayer film is not critical.

The tubular, multilayer film of the present invention is formed by extrusion. A co-extrusion die, such as shown in U.S. Patent No. 4,365,949, is utilized to coextrude
5 three laminate layers simultaneously. Polyethylene extrusion blocks are supplied to the die to extrude the inner and outer surface layers 20 and 22 respectively. An extrusion block containing a central barrier layer, such as polyvinylidene chloride, which is completely encapsulated in an adhesive layer is provided to the inlet opening of the die communicating with the middle extrusion passage, as will be discussed below. The central barrier
10 layer/adhesive composite extrusion block is extruded into a first stream having a generally annular cross-section. The middle extrusion passage is configured to ensure that there is an overlap of the central barrier layer along the weld line such that the thickness in the overlap portion is substantially the same thickness as in the non-overlapped portion, as will be discussed below. Because of this, the overlap produces an oxygen transmission rate in the
15 region of the weld line which is comparable to that provided in other areas of the film.

Fig. 3 shows the general layout of an extrusion line using two extruders to produce a preencapsulated core extrudate for use in making the multilayer film of the present invention. A core extruder 42 feeds a core extrudate of molten barrier material into a preencapsulation feedblock 44. Preencapsular extruder 32 feeds preencapsular extrudate
20 of preencapsular material to the preencapsulation feedblock 44 through a preencapsular transfer tube 48. In the preencapsulation feedblock 44, the core extrudate is surrounded by an annular layer of preencapsular material. This preencapsulated core extrudate flows through the preencapsulated core extrudate transfer tube 52 to the coextrusion die 38.

The molten core layer and preencapsulation layer are joined near the tip of
25 the screw of the core extruder. This minimizes the exposure of the core material to the walls of the extrusion equipment. This is particularly important for a thermally sensitive polymer, such as polyvinylidene chloride.

Fig. 4 shows the details of the preencapsulation feedblock 44. Gould et al., United States Patent No. 4,842,791, discloses a similar preencapsulation feedblock. The
30 preencapsulation feedblock 44 includes an axially arrayed series of members which define a

series of pathways for directing the flow of the core extrudate and the preencapsular extrudate. The preencapsulation feedblock 44 includes an inner member 62 disposed adjacent to the downstream end 64 of core extruder 42, a middle member 66 disposed axially outwardly from the inner member 62, and an outer member 68 disposed axially outwardly from middle member 66. The inner, middle, and outer members 62, 66, 68 are placed in an end-to-end, colinear relation, and are disposed between the downstream end 64 of the core extruder 42 and the upstream end of transfer tube 52. The inner, middle, and outer members 62, 66, and 68 are mounted to the core extruder by bolts 72 which pass through aligned openings in the inner, middle, and outer members 62, 66, 68. The bolts 72 are threadedly engaged in axially outwardly opening apertures 74 in the core extruder 42.

Inner member 62 is generally disk shaped, and includes an axially extending leg 76 having a conically shaped axially extending inner end 78. The conically shaped axially extending inner end 78 is disposed in a spaced, parallel relation to the downstream end 80 of the extrusion advancing screw 82 of the core extruder 42. Inner member 62 also includes an axially extending central pathway 84. The downstream end 80 of the extrusion advancing screw 82, and the conically shaped axially extending inner end 78, and central pathway 84 of the inner member 62 define a core extrudate pathway through which the core extrudate flows immediately after its extrusion by the core extruder 42.

Likewise, inner member 62 and middle member 66 cooperate to define a preencapsular extrudate pathway 86 in the preencapsulation feedblock 44 for directing preencapsular extrudate to the stream of core extrudate flowing through the central pathway 84. The preencapsular extrudate pathway 86 includes an inlet portion 88 for receiving the downstream end 90 of the preencapsular extrudate transfer tube 48, and thus for receiving the preencapsular extrudate flowing therein. The preencapsular extrudate pathway 86 also includes an L-shaped (in cross-section) portion 92 having a radially inwardly extending leg and an axially inwardly extending leg. The L-shaped portion 92 is disposed downstream from the inlet portion 88 and directs the preencapsular extrudate to a preencapsulation distribution manifold 94 formed between the axially extending outer surface 96 of inner member 62 and the axially inner surface 98 of middle member 66. A radially inwardly extending inner mandrel 100 extends between the preencapsulation distribution manifold 94 and the outlet portion 102 of the preencapsular extrudate pathway 86. The outlet portion

102 circumferentially surrounds the downstream end of the central pathway 84, and extends generally axially to direct the flow of the preencapsular extrudate in an axial direction, so that the preencapsular extrudate flowing out of the outlet portion 102 joins the core extrudate flowing out of the central pathway 84 in a coaxial, surrounding relation in the preencapsulated core extrudate pathway 104.

The preencapsulated core extrudate pathway 104 is disposed colinearly with the central pathway 84 and has a cross-sectional area generally equal to the combined cross-sectional areas of the outlet portion 102 of the preencapsular extrudate pathway 86 and the central pathway 84, so that the flows of core and preencapsular material are not substantially restricted in preencapsulated core extrudate pathway 104. Preencapsulated core extrudate transfer tube 52 includes interior passageway 106 having an upstream end 108. The upstream end 108 of the interior passageway 106 of the preencapsulated core extrudate transfer tube 52 is disposed colinearly with, and has generally the same cross-sectional area as the preencapsulated core extrudate pathway 104 so as not to introduce perturbations in the flow of the preencapsulated core extrudate as it moves from pathway 104 into the interior passageway 106. A collar 110 is formed at, or fixed to, the upstream end 108 of preencapsulated core extrudate transfer tube 52. The collar 110 is mateable with the axially outwardly facing surface 112 of middle member 66, for properly positioning preencapsulated core extrudate transfer tube 52 on the preencapsulation feedblock 44. The ring-shaped outer member 68 of the preencapsulation feedblock 44 serves as a yoke for maintaining the collar 110 in the preencapsulation feedblock 44.

Fig. 5 shows a plate of one embodiment of the preencapsulation die. Middle member 66 (shown in Fig. 4) has a preencapsulated core extrudate pathway 104. An inner mandrel 100 extends circumferentially around the preencapsulated core extrudate pathway 104. A preencapsulation distribution manifold 94 extends circumferentially around the inner mandrel 100. There is a resin inlet 158 in the preencapsulation distribution manifold 94. The inner mandrel 100 is flat. As a result, the die gap between the inner mandrel 100 and the surface 96 of the inner member 62 (shown in Fig. 4) is the same at all points around the circumference of the die. This produces a preencapsulated core extrudate as shown in Fig. 6. The preencapsulated core extrudate has a preencapsulation layer 152 positioned annularly around the core layer 150. The preencapsulation layer 152 has a uniform

thickness around the round core layer 150. The surface of the inner member 62 can be a mirror image of the die plate shown in Fig. 5. Alternatively, for ease of construction, it is preferable that the surface of inner member 62 be flat.

5 A preencapsulated core extrudate with uniform layer thicknesses is not always the preferred structure to send to the tubular coextrusion die. In some cases, when the preencapsulated core extrudate has uniform layer thicknesses, the tubular film produced does not have the desired barrier layer in the overlap. Too much preencapsular material flows into the overlap area, resulting in a thick layer of preencapsular material and a thin barrier layer in the overlap area.

10 The thickness of the encapsulation layer around the core material can be controlled selectively. This is done by creating a gap in the preencapsulation die land area having different thicknesses around its circumference, thus promoting or retarding flow through those areas of the die. This allows better control of the final layer thickness profiles for each individual layer in the final film structure. The shaping of the preencapsular material results in a more uniform core layer and preencapsular layer in the overlap.

15 Fig. 7 shows a plate of an alternate embodiment of the preencapsulation die. In this embodiment, the die has a non-uniform die gap. Middle member 66 (shown in Fig. 4) has a preencapsulation distribution manifold 94, an inner mandrel 100, and a preencapsulated core extrudate pathway 104, as before. There is a resin distribution channel 20 160 which extends circumferentially about 180 degrees around the preencapsulation distribution manifold 94. The resin distribution channel 160 is separated from the preencapsulation distribution channel 94 by a wall 162. There are openings 164 and 166 on each end of the resin distribution channel 160 which allow resin to flow from the resin distribution channel 160 into the preencapsulation distribution manifold 94. The resin inlet 25 158 is located about midway between the ends of the resin distribution channel 160.

The inner mandrel 100 has a pair of first surfaces 170 and 172 and a pair of second surfaces 174 and 176. The first surfaces 170 and 172 are lower than the second surfaces 174 and 176. When paired with either a flat surface or a mirror image on the surface 96 of inner member 62, this produces a bigger die gap between the inner mandrel 30 100 and the surface 96 of the inner member 62 at the first surfaces 170 and 172 than at

second surfaces 174 and 176. The bigger die gap allows more polymer to flow through first surfaces 170 and 172, which produces non-uniform layer thicknesses as shown in Fig. 8. The preencapsulation layer 182 is thicker at the top and bottom than on the sides.

5 The first surfaces 170 and 172 of the inner mandrel produce the thicker top and bottom portions of the preencapsulation layer, and second surfaces 174 and 176 produce the thinner side portions. It was expected that the first surfaces should be larger than the second surfaces to obtain the shape shown in Fig. 8. However, initial experiments in which the first surfaces were much larger than the second surfaces did not yield the desired shape. Surprisingly, it was discovered that in order to produce a preencapsulated core extrudate as shown in Fig. 8, the first surfaces 170 and 172 should extend for approximately 60 degrees around the preencapsulated core extrudate pathway 104 on opposite sides of the inner mandrel 100, and the second surfaces 174 and 176 should extend for approximately 120 degrees. Other designs are possible depending on the desired profile of the preencapsulated core extrudate and the particular materials to be used in the film.

15 The transition 178 between first surfaces 170 and 172 and second surfaces 174 and 176 is preferably inclined to allow smooth polymer flow from the deeper portion to the shallower portion.

The preencapsulated core extrudate is sent to a tubular die where it flows through a distribution manifold to produce a tubular structure in which the ends of the core layer are overlapped. A representative cylindrical distribution manifold is shown in Figs. 9-20 11. Fig. 9 shows the inlet side of the distribution manifold 200, and Figs. 10 and 11 show the opposite side. The distribution manifold 200 has a body 202. The body has an inlet end 204 and an outlet end 206. The body 202 can be cylindrical or other suitable shape. It can be a straight cylinder in which the inlet end 204 and the outlet end 206 are the same diameter. Alternatively, the cylinder can be tapered, with either the inlet end 204 being larger in diameter than the outlet end 206, or the inlet end 204 being smaller in diameter than the outlet end 206.

25 There is a resin inlet 208 near the inlet end 204 of the body 202. The resin inlet 208 is connected to a pair of manifold channels 210 and 212. The pair of manifold channels 210 and 212 has substantially the same length. They extend from the resin inlet

30

208 around the body 202 in opposite directions. The pair of manifold channels 210 and 212 preferably spiral upward from the inlet end 204 toward the outlet end 206 of the body 202. On the opposite side of the body 202, the ends 214 and 216 of the manifold channels 210 and 212 overlap each other. The manifold channels decrease in cross-sectional area from
5 the resin inlet 208 to the ends 214 and 216.

Figs. 10 and 11 show one embodiment of how to achieve the overlap of the core layer. Manifold channel 210 spirals upward toward the outlet end 206 of the body 202. Manifold channel 210 extends onto an insert 218, and continues to end 214. Underneath the insert 218, there is a depression 220. Manifold channel 212 extends into the depression 220
10 and continues to end 216. Because the end 216 of manifold channel 212 is in depression 220 and the end 214 of manifold channel 210 is on insert 218, the ends 214 and 216 of the manifold channels 210 and 212 are at different radial distances from the center of body 202.

When the insert 218 is in place, resin flows through manifold channel 212 to end 216 underneath the insert 218. At the same time resin flows through manifold channel
15 210 to end 214. There is a set distance 224 of overlap by the ends 214 and 216 of the manifold channels 210 and 212. The resin in the ends 214 and 216 of manifold channels 210 and 212 remains separated by the insert 218.

For a uniform total barrier layer thickness, the minimum set distance 224 of overlap depends on the particular barrier material being used and the thickness of the barrier
20 film layer. The set distance needed for a specific barrier material and thickness of barrier film layer can be determined by Equation 1.

Equation 1: $OL = PE/PB \times BLT$

Where:

OL = Overlap Length;

25 PE = Permeability per mil of the Encapsulation material;

PB = Permeability per mil of the Barrier material;

BLT = Barrier Layer Thickness.

The permeabilities in Equation 1 are for the permeant molecule of interest. As used herein, the term "permeant" refers to a gas or vapor that passes through a polymeric
30 material. Since the permeabilities of resins can differ substantially for different permeants,

the necessary overlap length may vary depending on choice of permeant. Table 1 shows an example of necessary overlap lengths based on oxygen permeability for specific vinylidene chloride copolymer (SARAN™) and tie layer material (EVA) combinations.

Barrier Material	Barrier Perm.*	Barrier Thick. (in.)	Encaps. Material	Encaps Perm.*	Overlap Length (in.)
SARAN	0.08	0.005	EVA	400	2.5
SARAN	0.08	0.002	EVA	400	1.0
SARAN	0.08	0.005	Grafted HDPE	150	0.94

*Permeability in cc/100 sq. in.-day-atm

5 The manifold channels may be designed to assist in producing an encapsulated structure with uniform layers. Since the manifold will contain an encapsulated structure, the effects of viscous encapsulation and elastic layer rearrangement should be minimized in order to maintain a uniform layer structure as it flows down the manifold channel. These effects can be minimized by using channels that are streamlined and use
10 large radii in any corners. One preferred channel geometry for producing uniform layers would be a teardrop shape manifold with an aspect ratio of height to depth of greater than 3:1. Fig. 12 shows one example of a preferred manifold channel having a height to depth ratio (h:d) of greater than 3:1.

Example 1

15 A copolymer of polyvinylidene chloride and methyl acrylate (including typical additives) was fed through a core extruder with a diameter of 4.45 cm and a length to diameter ratio 24:1. The temperature of the core extruder was controlled in three barrel zones: 149°C/154°C/154°C for the feed/transition/metering sections of the core extruder, respectively. A screw speed of 35 rpm was used in the primary extruder resulting in an
20 output rate of 17 kg/hr.

An ethylene vinyl acetate resin with a melt flow of 6 gm/10 min. and 28 percent vinyl acetate was fed through a side arm extruder with a diameter of 3.18 cm and a length to diameter ratio of 20:1. The temperature of the side arm extruder was controlled in three barrel zones: 121°C/149°C/149°C for the feed/transition/meter sections of the side arm extruder, respectively. A screw speed of 18 rpm was used in the side arm extruder, resulting in an output rate of 2 kg/hr.

The melt streams of the copolymer of polyvinylidene chloride and methyl acrylate from the core extruder and ethylene vinyl acetate from the side arm extruder were fed into a preencapsulation feedblock as described above. The layer thickness of the ethylene vinyl acetate layer was controlled to produce the desired layer thickness in the final product, as shown in Fig. 8. From the feedblock, the encapsulated material was passed through a crosshead style blown film die manifold in which the ends of the manifold were overlapped, as described above. The encapsulated structure was joined with two ethylene vinyl acetate adhesive layers and two polyethylene layers in an A/B/C/B/A structure (where A is polyethylene, B is ethylene vinyl acetate adhesive layer, and C is the copolymer of polyvinylidene chloride and methyl acrylate encapsulated in ethylene vinyl acetate) to produce the final blown film structure.

Example 2

In order to evaluate the effect of the preencapsulation die, blown film was produced using the encapsulation dies shown in Figs. 5 and 7. The film incorporated a polyvinylidene chloride central barrier layer, and ethylene vinyl acetate adhesive layers. In the first run with the uniform die gap in the preencapsulation die, it was difficult to see the layer thicknesses. As a result, the layer thicknesses were increased when the film with the non-uniform die gap in the preencapsulation die was produced in order to see the layers better.

The film was tested for oxygen permeability. The results are shown in Table 2.

Table 2

Uniform Die Gap v. Non-Uniform Die Gap In Preencapsulation Die

Run	Die Gap	(1) Permeability* (In Overlapped Region (-2 in. to +2 in.)**	(2) Permeability* (Away from Overlapped Region (+18 in. to +22 in.)**	Permeability Ratio - ((1)/(2))
1	Uniform	1.40	0.30	4.6
2	non-uniform	0.18	0.13	1.38

*Permeability in cc/100 sq.in.-day-atm

5 **4-inch diameter piece of film used for barrier measurement.

Table 3

Total Percent Saran Vs. Position Around Film

Position (In)*	Uniform Insert	Non-uniform Insert
	SARAN	SARAN
-22	15.4	14.5
-14	15.9	
-10	16	15.2
-6	14	12.9
-5	14.8	-
-4	13.9	-
-3	11.6	13.3
-2	8.1	11.3
-1	2.6	10.5
0	5	11.9
+1	6.2	11.9
+2	9.5	9
+3	10.9	10.2
+4	14.7	14.9
+5	15.3	-
+6	16.6	-
+10	15.4	16
+14	16.4	-
+22	15.4	14.5

*Position = Distance from the point opposite the entry port of the SARAN extruder

The increase in the layer thicknesses with the shaped preencapsulation accounts for the differences in the absolute values of the permeability. The film produced with the uniform die gap in the preencapsulation die did not have a uniform barrier layer
5 around the circumference of the tube. The increased permeability at the overlap region shows that the barrier layer at the weld was not uniform. In contrast, the film made with the non-uniform die gap in the preencapsulation die had a permeability at the overlap region which was close to the permeability away from the overlap region.

While certain representative embodiments and details have been shown for
10 purposes of illustrating the invention, it will be apparent to those skilled in the art that various changes in the compositions, methods, and apparatus disclosed herein may be made without departing from the scope of the invention, which is defined in the appended Claims.

50431-6(S)

CLAIMS:

1. An extrusion apparatus for coextruding a multilayer film from a plurality of feed-stock materials comprising:

- 5 a core extruder for extruding a core extrudate;
- a preencapsulation die disposed adjacent the outlet of the core extruder; the preencapsulation die having a gap in the dieland area with different thicknesses around its circumference for producing a non-uniform encapsulation
- 10 layer thickness;
- a preencapsular extruder for extruding a preencapsular extrudate;
- a preencapsular transfer tube for transferring the preencapsular extrudate to the preencapsulation die where
- 15 the preencapsular extrudate surrounds the core extrudate to form a preencapsulated core extrudate;
- a coextrusion die having a distribution manifold comprising a body having an inlet end and an outlet end, a manifold inlet near the inlet end of the body, and a pair of
- 20 manifold channels extending from the manifold inlet around the body in opposite directions, opposite ends of the manifold channels overlapping each other such that the preencapsulated core extrudate in the overlapping ends of the manifold channels remains separated; and
- 25 a preencapsulated core extrudate transfer tube disposed downstream of the preencapsulation die for transferring the preencapsulated core extrudate to the coextrusion die.

50431-6(S)

2. The extrusion apparatus of Claim 1 wherein the pair of manifold channels have the same length.

3. The extrusion apparatus of Claim 1 wherein opposite ends of the manifold channels overlap each other by
5 a distance at a point opposite the manifold inlet.

4. The extrusion apparatus of Claim 1 wherein the opposite ends of the manifold channels are at different radial distances from a center of the body.

5. The extrusion apparatus of Claim 1 wherein the
10 manifold channels have a streamlined shape.

6. The extrusion apparatus of Claim 1 wherein the manifold channels have a teardrop shape.

7. The extrusion apparatus of Claim 1 wherein the manifold channels have an aspect ratio of height to depth of
15 greater than 3:1.

8. The extrusion apparatus of Claim 1 wherein the distance of overlap is at least an amount as determined by the following Equation:

$$OL = PE/PB \times BLT$$

20 Where:

OL = Overlap Length;

PE = Permeability per mil of the Encapsulation material;

PB = Permeability per mil of the barrier material;

25 BLT = Barrier Layer Thickness.

50431-6(S)

9. The extrusion apparatus of Claim 1 further comprising a depression in the body located where the manifold channels overlap, the distance of overlap of the end of one manifold channel being located in the depression,
5 and an insert positioned over the depression, the depression and the insert defining a gap therebetween so that the preencapsulated core extrudate from the end of the manifold channel located in the depression flows through the gap.

10. The extrusion apparatus of Claim 1 wherein the
10 body is a cylinder.

11. The extrusion apparatus of Claim 10 wherein the cylinder is tapered.

12. The extrusion apparatus of Claim 1 wherein the body is planar.

15 13. A preencapsulation die for preencapsulating thermally sensitive polymer comprising:

a die body having an annular opening therethrough, the die body having a first member and a second member adjacent to the first member;

20 an inner mandrel extending circumferentially around the annular opening in the first member, the inner mandrel having a first surface and a second surface, the first surface being lower than the second surface whereby the first surface of the inner mandrel and the second member
25 define a first die gap and the second surface of the inner mandrel and the second member define a second die gap, the first die gap being greater than the second die gap, and whereby the preencapsulation die is capable of producing a non-uniform encapsulation layer thickness; and

50431-6(S)

a preencapsulation distribution manifold extending circumferentially around the inner mandrel in the first member.

14. The preencapsulation die of Claim 13 further
5 comprising a resin distribution channel extending about 180 degrees circumferentially around the preencapsulation distribution manifold in the first member, the resin distribution channel terminating in an opening at each end, the openings in the resin distribution channel
10 communicating with the preencapsulation distribution manifold, the resin distribution channel communicating with a resin inlet, the resin inlet being located intermediate the openings in the resin distribution channel, the openings in the resin distribution channel being positioned adjacent
15 the first surface of the inner mandrel.

15. The preencapsulation die of Claim 13 wherein the inner mandrel has a pair of first surfaces and a pair of second surfaces, the first surfaces extending approximately 60 degrees around the annular opening and the second
20 surfaces extending approximately 120 degrees around the annular opening.

16. The preencapsulation die of Claim 14 wherein the inner mandrel has a pair of first surfaces and a pair of second surfaces, the first surfaces extending approximately
25 60 degrees around the annular opening and the second surfaces extending approximately 120 degrees around the annular opening, the first surfaces being positioned on opposite sides of the inner mandrel adjacent to the openings in the resin distribution channel, the second surfaces being
30 positioned between the first surfaces on opposite sides of the inner mandrel.

50431-6(S)

17. A method for coextruding a multilayer tubular film having a barrier material comprising:

extruding a core extrudate of barrier material with a core extruder;

5 providing a preencapsulation die adjacent the outlet of the core extruder, the preencapsulation die capable of producing a non-uniform layer thickness;

extruding a preencapsular extrudate of preencapsular material and directing said preencapsular
10 extrudate to the preencapsulation die;

joining the core extrudate and the preencapsular extrudate in the preencapsulation die in a coaxial relationship wherein the preencapsular extrudate is disposed radially outwardly of the core extrudate to form a
15 preencapsulated core extrudate having a non-uniform layer thickness;

extruding an inner layer extrudate and an outer layer extrudate;

feeding the preencapsulated core extrudate through
20 a distribution manifold to a coextrusion die, the distribution manifold designed to overlap opposing longitudinally extending edges of the preencapsulated core extrudate; and

forming a multilayer blown film having the inner
25 layer extrudate disposed radially inwardly of the preencapsulated core extrudate and the outer layer extrudate disposed radially outwardly of the preencapsulated core extrudate.

50431-6(S)

18. The method of Claim 17 wherein the inner layer extrudate and the outer layer extrudate are joined to the preencapsulated core extrudate before the preencapsulated core extrudate is fed through the coextrusion die.

5 19. The method of Claim 17 wherein the inner layer extrudate and the outer layer extrudate are joined to the preencapsulated core extrudate while the preencapsulated core extrudate is fed through the coextrusion die.

20. The method of Claim 17 further comprising
 10 extruding a second inner layer extrudate disposed inwardly of the inner layer extrudate and a second outer layer extrudate disposed outwardly of the outer layer extrudate.

21. The method of Claim 17 wherein the distance of overlap is at least an amount as determined by the following
 15 Equation:

$$OL = PE/PB \times BLT$$

Where:

OL = Overlap Length;

20 PE = Permeability per mil of the Encapsulation material;

PB = Permeability per mil of the barrier material;

BLT = Barrier Layer Thickness.

22. An extrusion apparatus for coextruding a multilayer film from a plurality of feedstock materials
 25 comprising:

a core extruder for extruding a core extrudate;

50431-6(S)

a preencapsulation die disposed adjacent the outlet of the core extruder, the preencapsulation die comprising:

5 a die body having an annular opening therethrough, the die body having a first member and a second member adjacent to the first member;

10 an inner mandrel extending circumferentially around the annular opening in the first member, the inner mandrel having a first surface and a second surface, the first surface being lower than the second surface whereby the first surface of the inner mandrel and the second member define a first die gap and the second surface of the inner mandrel and the second member define a second die gap, the first die gap being greater than the second die gap and
15 whereby the preencapsulation die produces a non-uniform encapsulation layer thickness; and

a preencapsulation distribution manifold extending circumferentially around the inner mandrel in the first member;

20 a preencapsular extruder for extruding a preencapsular extrudate;

a preencapsular transfer tube for transferring the preencapsular extrudate to the preencapsulation die;

25 a coextrusion die having a distribution manifold designed to overlap opposing longitudinally extending edges of the preencapsular extrudate; and

a preencapsulated core extrudate transfer tube disposed downstream of the preencapsulation die for transferring the preencapsulated core extrudate to the
30 coextrusion die.

50431-6(S)

23. The extrusion apparatus of Claim 22 wherein the preencapsulation die further comprises a resin distribution channel extending 180 degrees circumferentially around the preencapsulation distribution manifold in the first member,
5 the resin distribution channel terminating in an opening at each end, the openings in the resin distribution channel communicating with the preencapsulation distribution manifold, the resin distribution channel communicating with a resin inlet, the resin inlet being located intermediate
10 the openings in the resin distribution channel, the openings in the resin distribution channel being positioned adjacent the first surface of the inner mandrel.

24. The extrusion apparatus of Claim 22 or 23 wherein the inner mandrel has a pair of first surfaces and a pair of
15 second surfaces, the first surfaces extending 60 degrees around the annular opening and the second surfaces extending 120 degrees around the annular opening.

25. The extrusion apparatus of Claim 22, 23, or 24 wherein the distribution manifold of the coextrusion die
20 comprises:

a body having an inlet end and an outlet end;

a manifold inlet near the inlet end of the body;

a pair of manifold channels having substantially the same length extending from the manifold inlet around the
25 body in opposite directions, opposite ends of the manifold channels overlapping each other by a distance at a point opposite the manifold inlet, the opposite ends at different radial distances from a center of the body such that polymer in the overlapping ends of the manifold channels remains
30 separated, the manifold channels decreasing in cross-sectional area from the manifold inlet to the opposite end.

50431-6(S)

26. The extrusion apparatus of Claim 25 further comprising a depression in the body located where the manifold channels overlap, the distance of overlap of the end of one manifold channel being located in the depression,
5 and an insert positioned over the depression, the distance of overlap of the end of the second manifold channel being located on the insert, the depression and the insert defining a gap therebetween so that the preencapsulated core extrudate from the end of the manifold channel located in
10 the depression flows through the gap.

SMART & BIGGAR

OTTAWA, CANADA

PATENT AGENTS

1/4

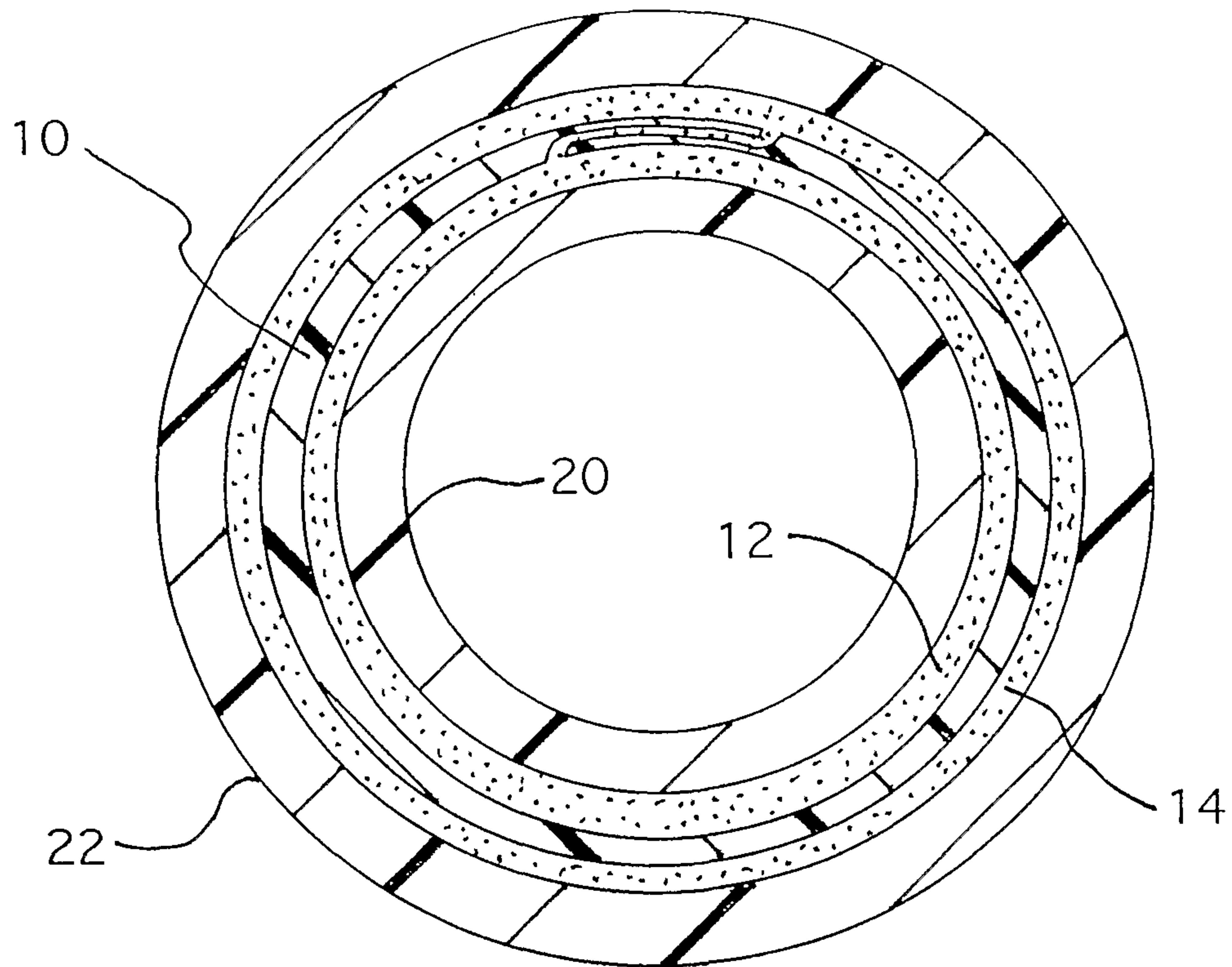

Fig. 1 (PRIOR ART)

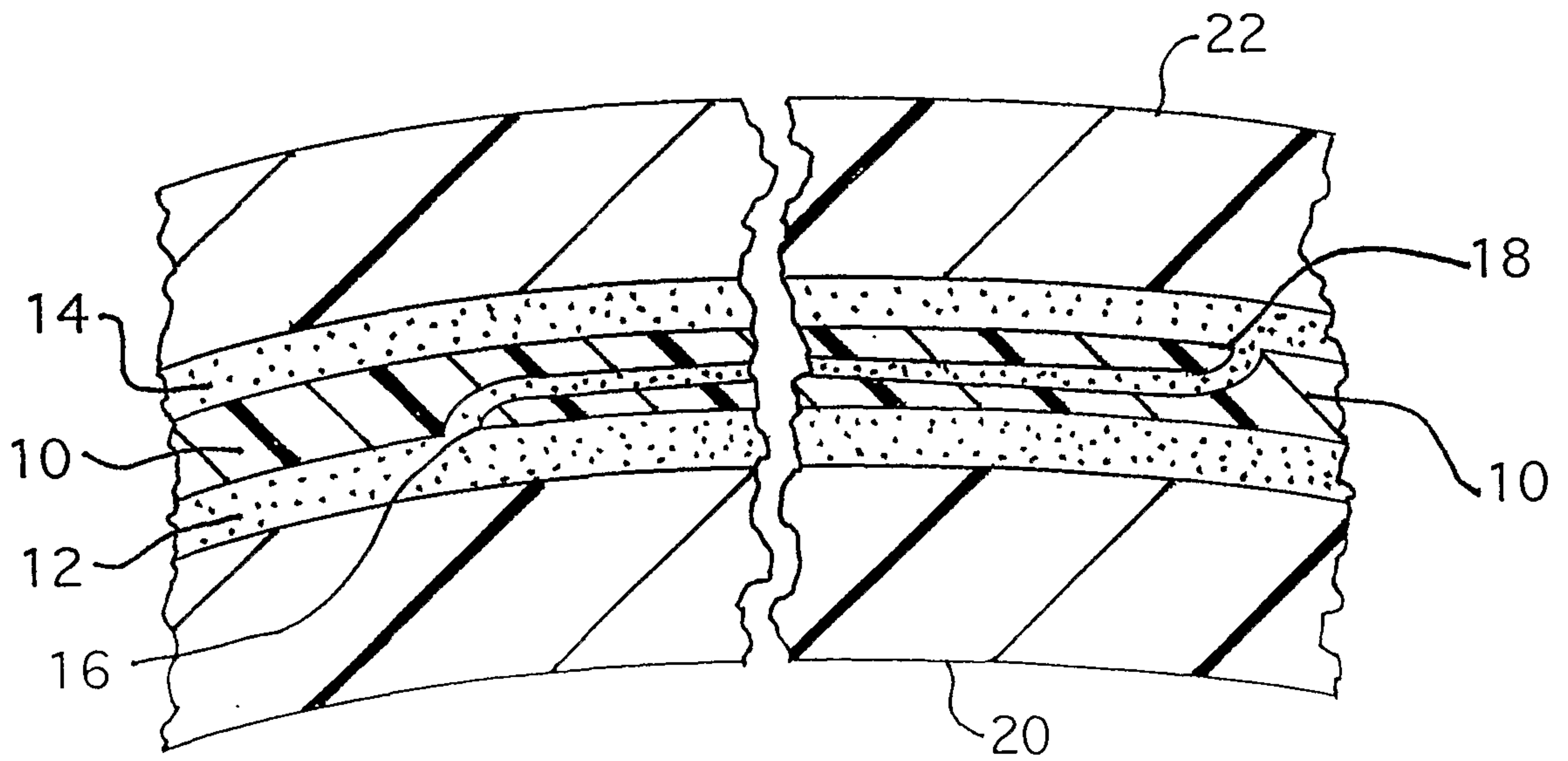

Fig. 2 (PRIOR ART)

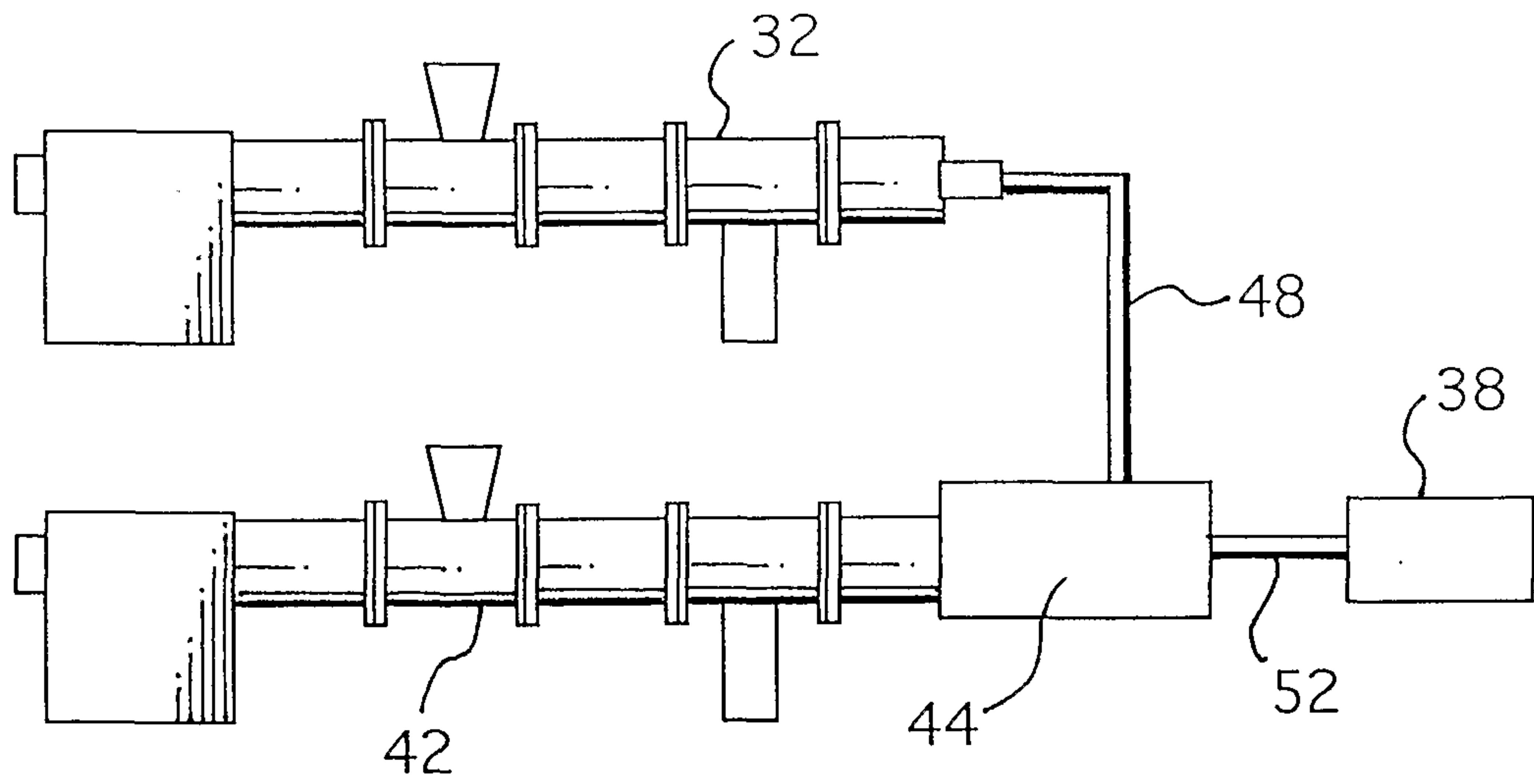

Fig. 3

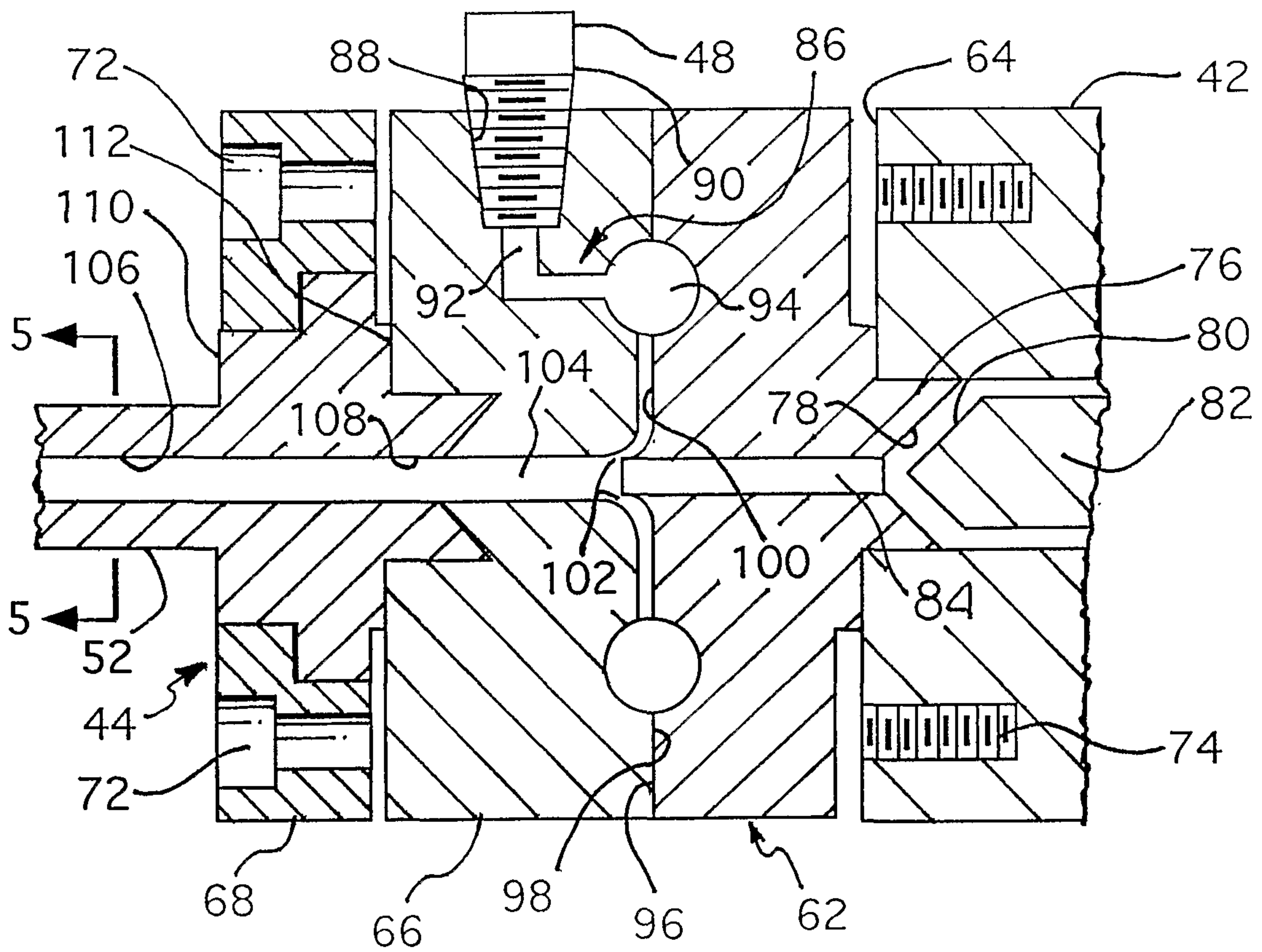

Fig. 4

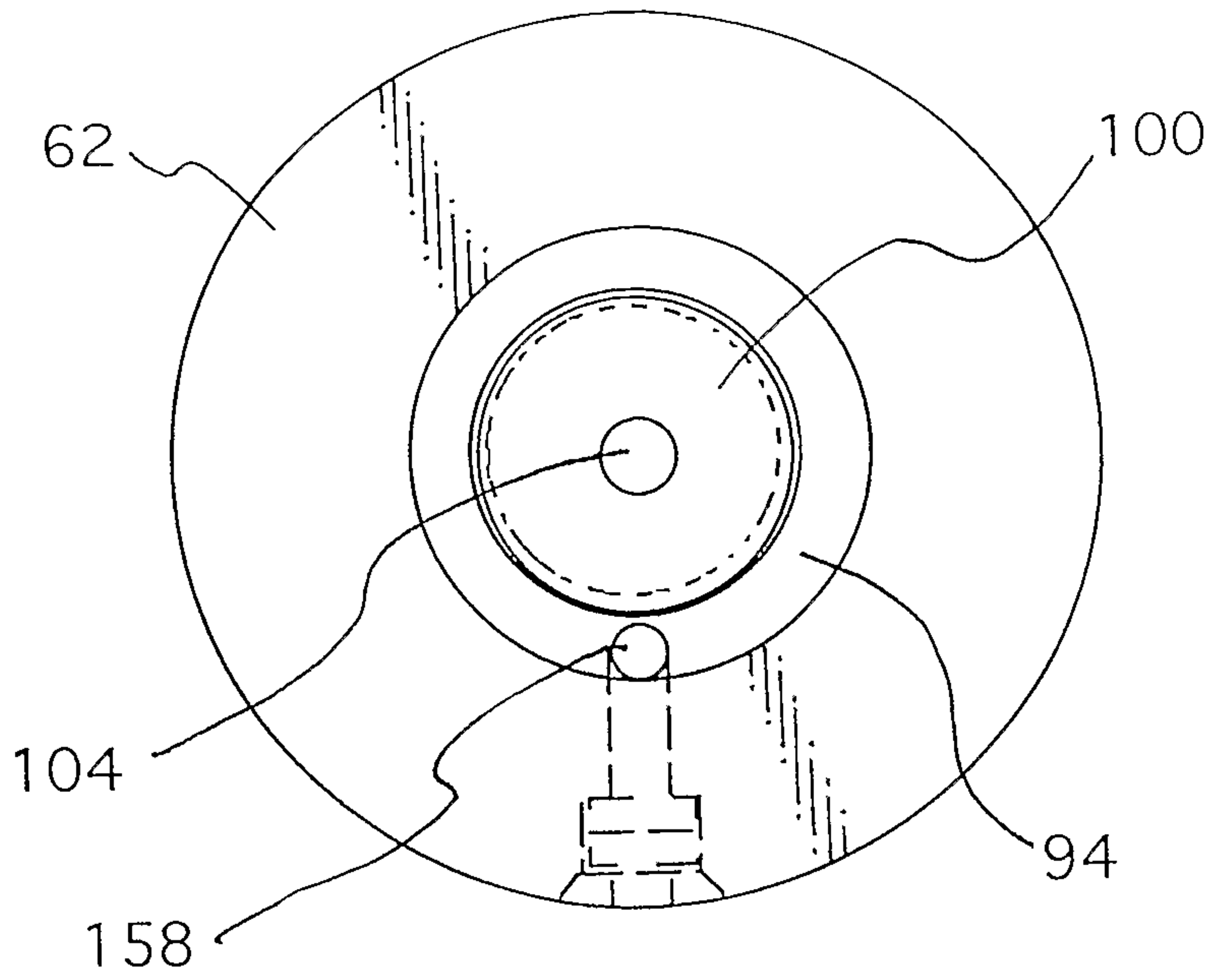

Fig. 5

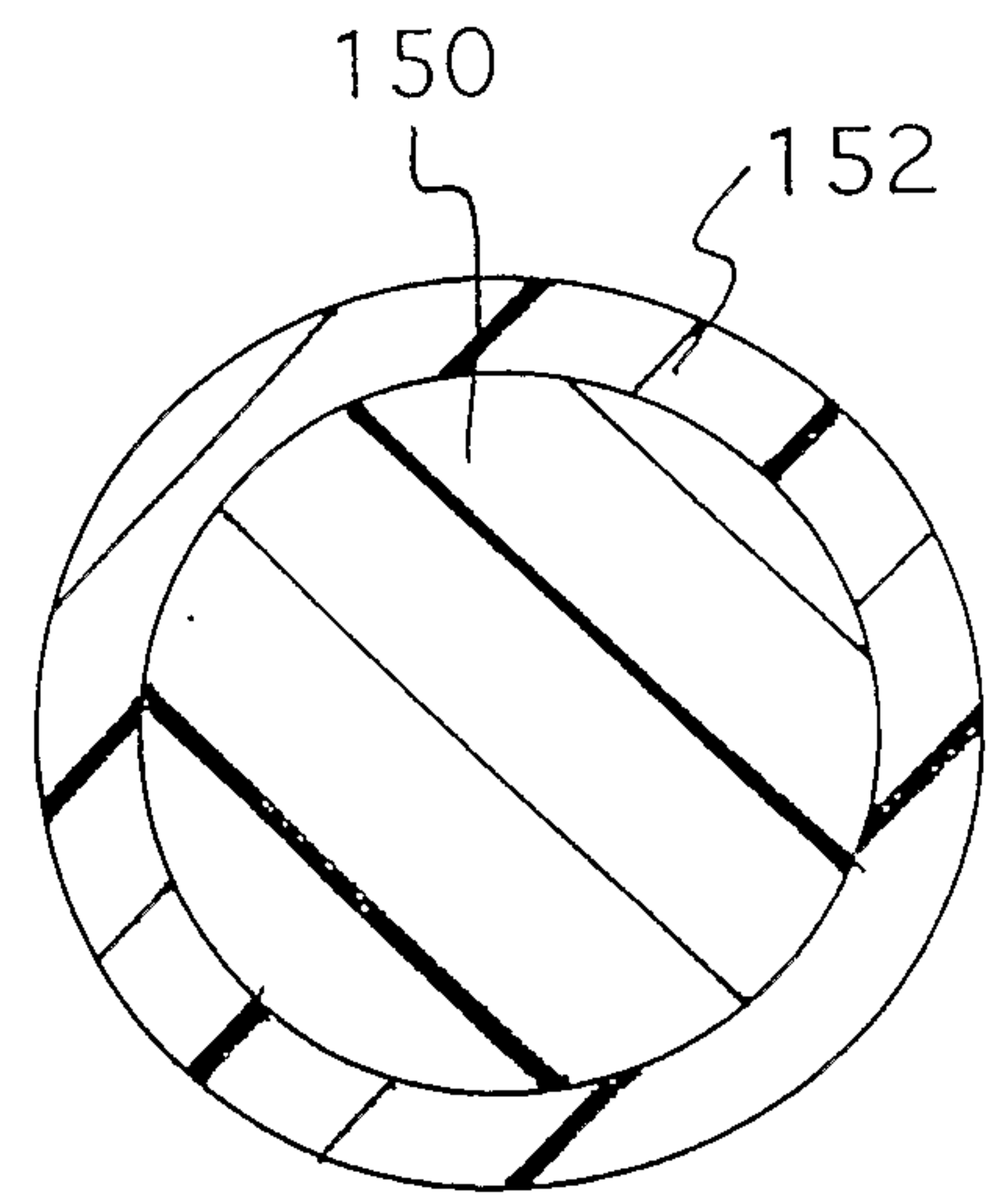

Fig. 6

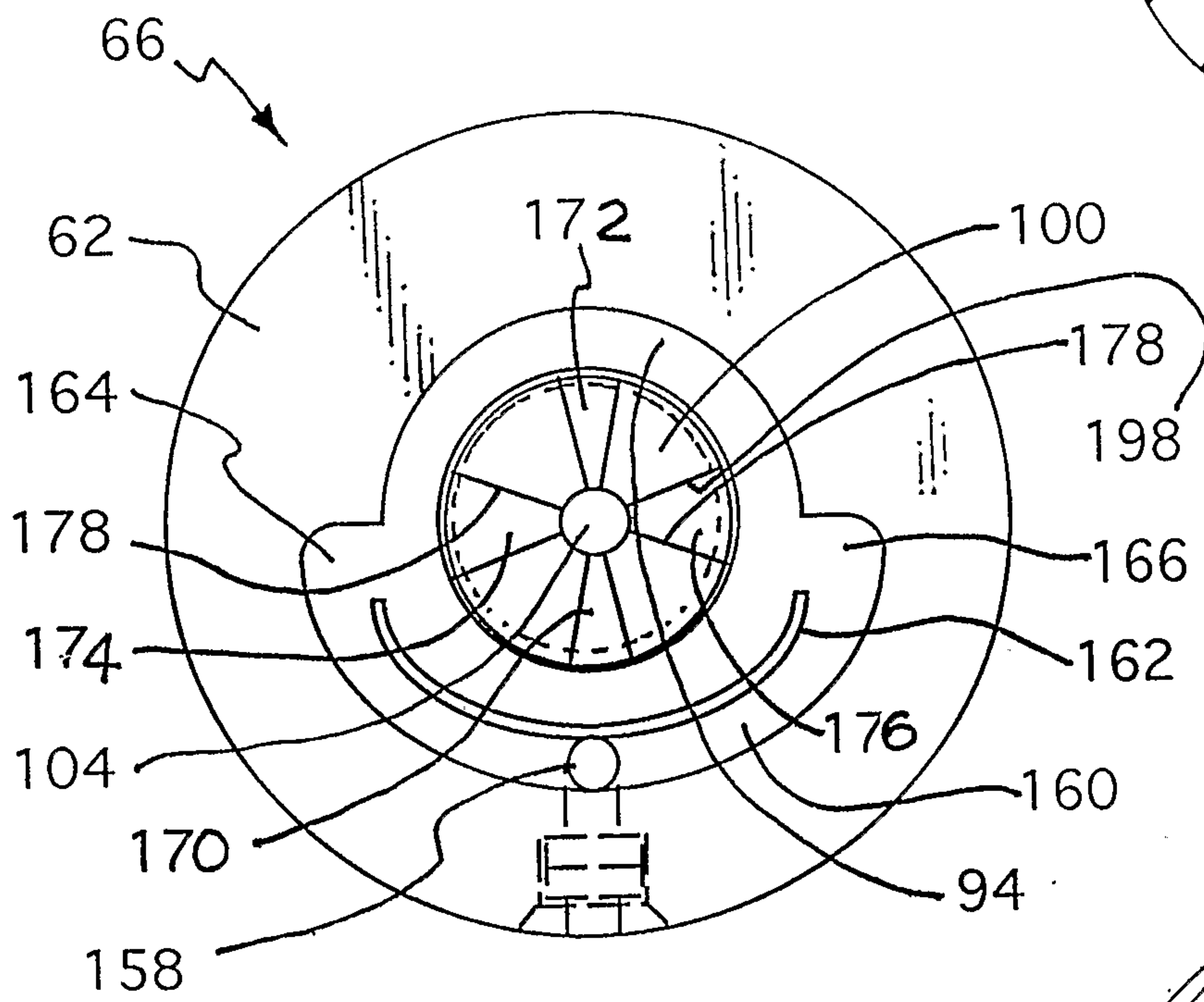

Fig. 7

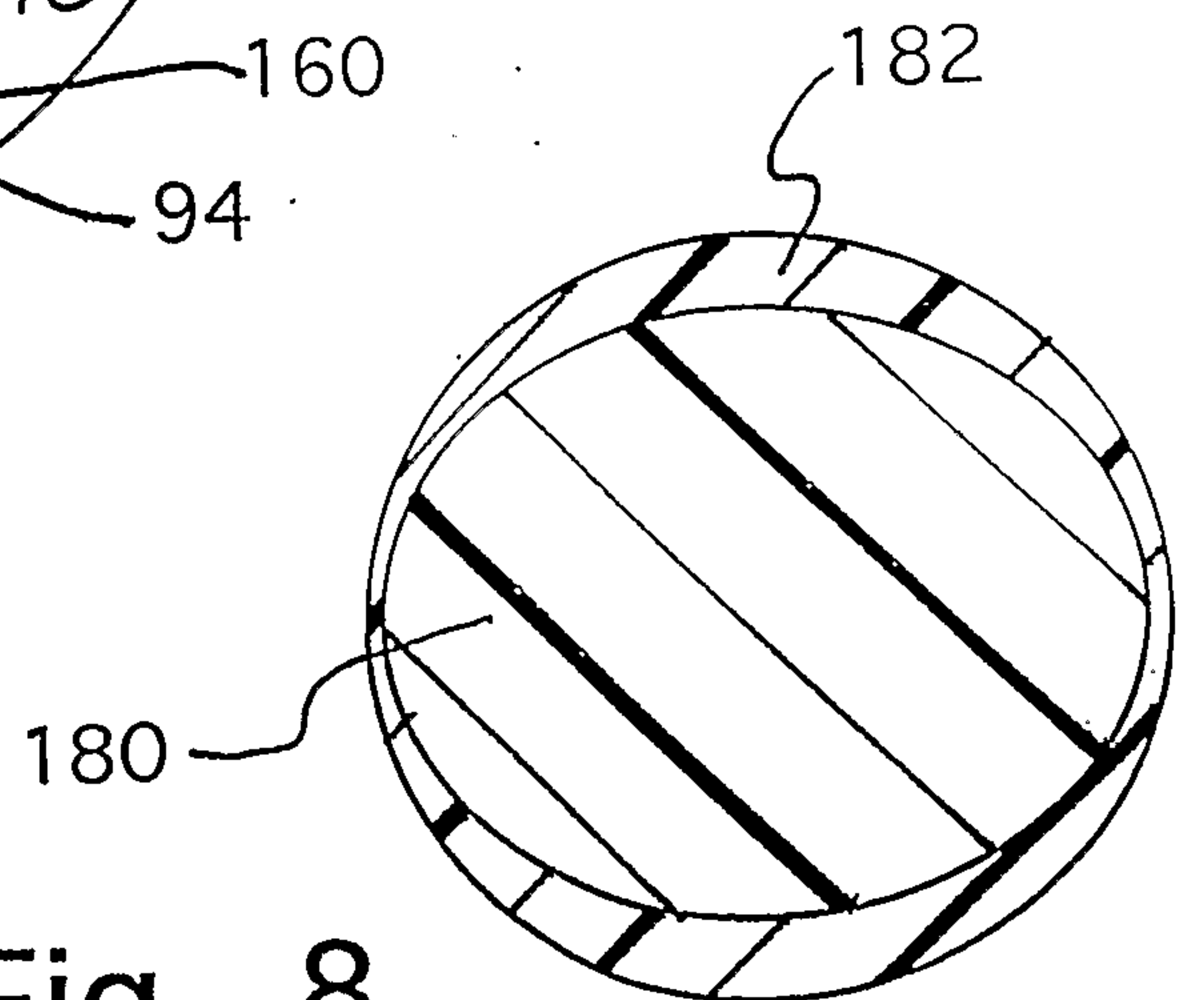

Fig. 8

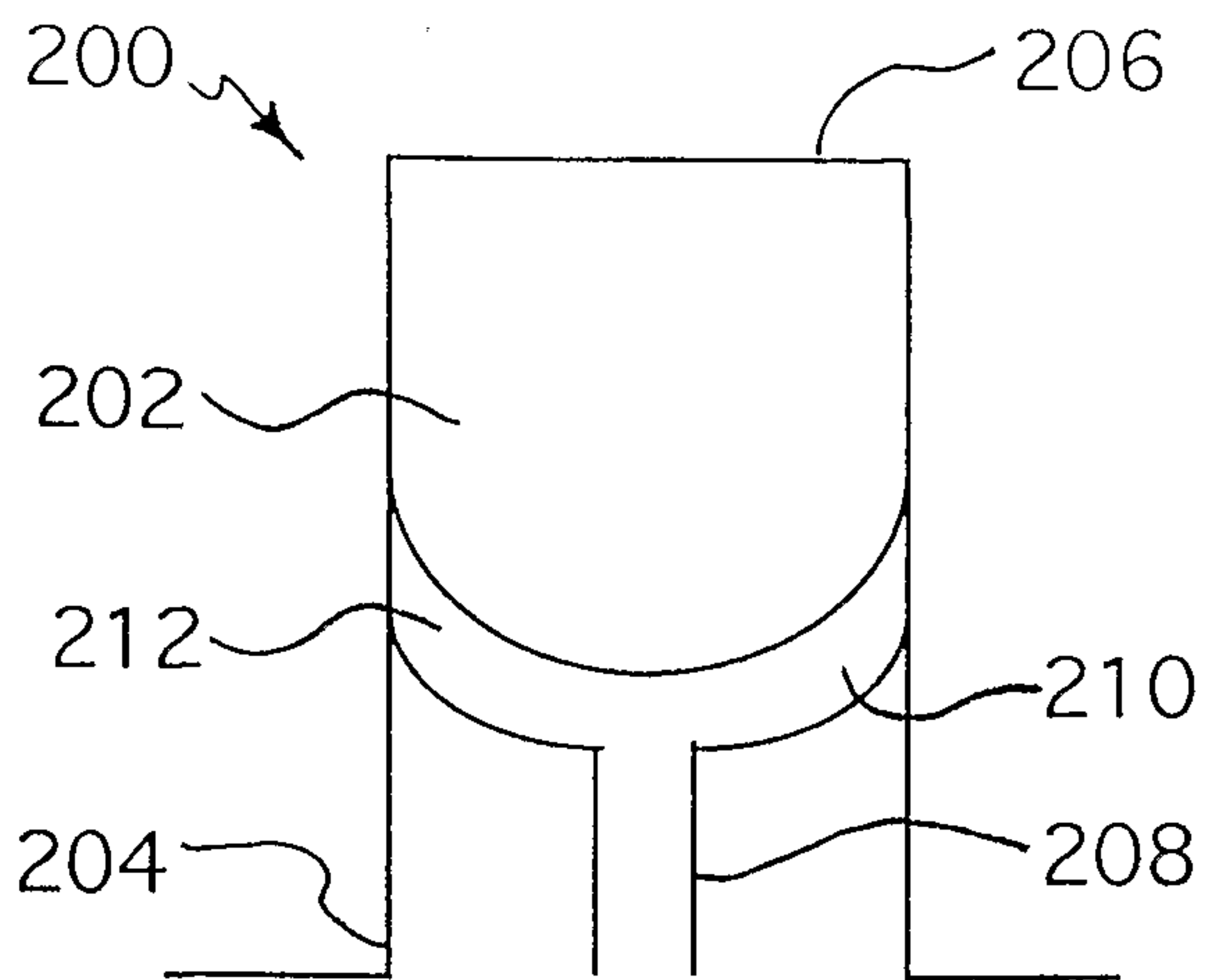

Fig. 9

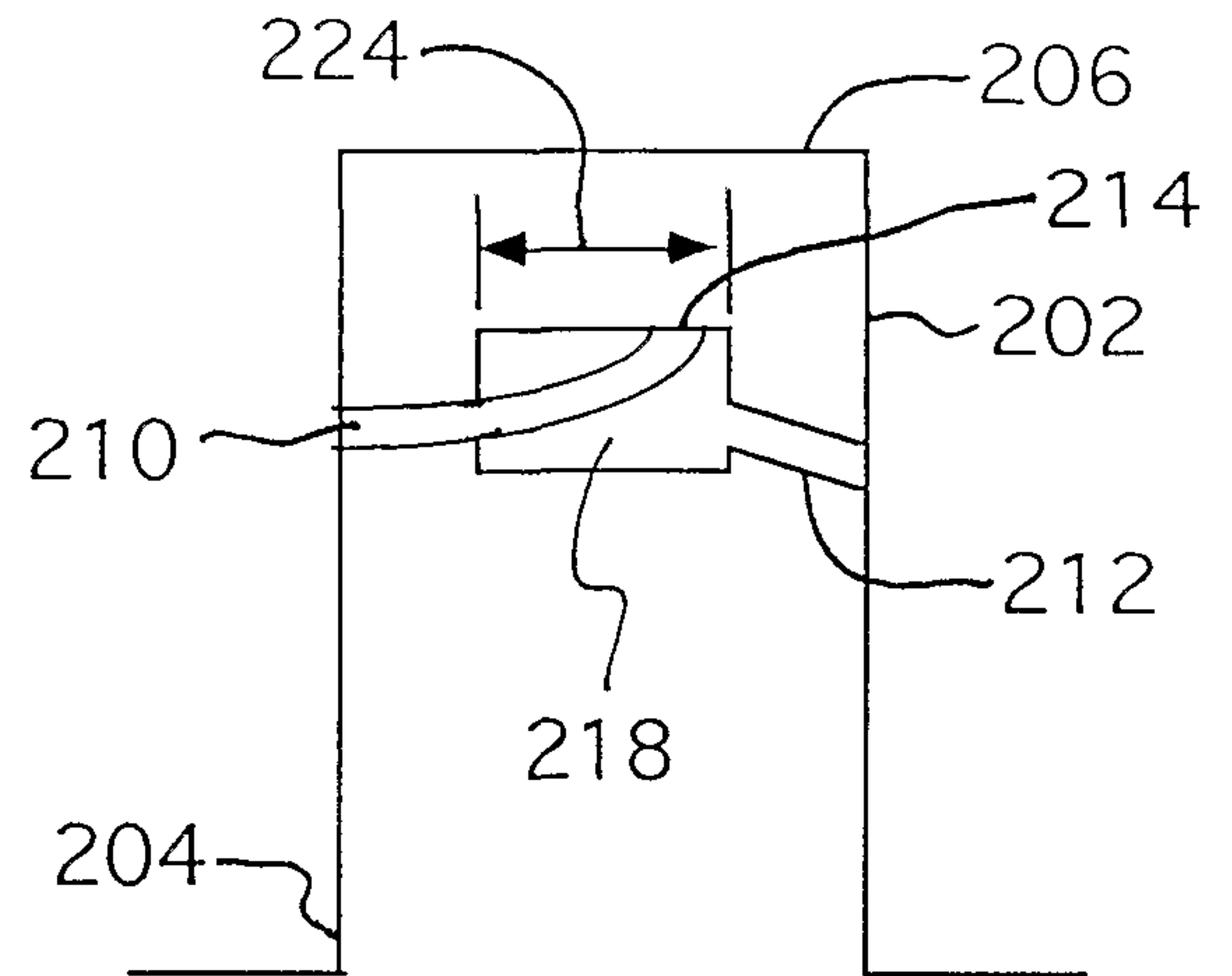

Fig. 10

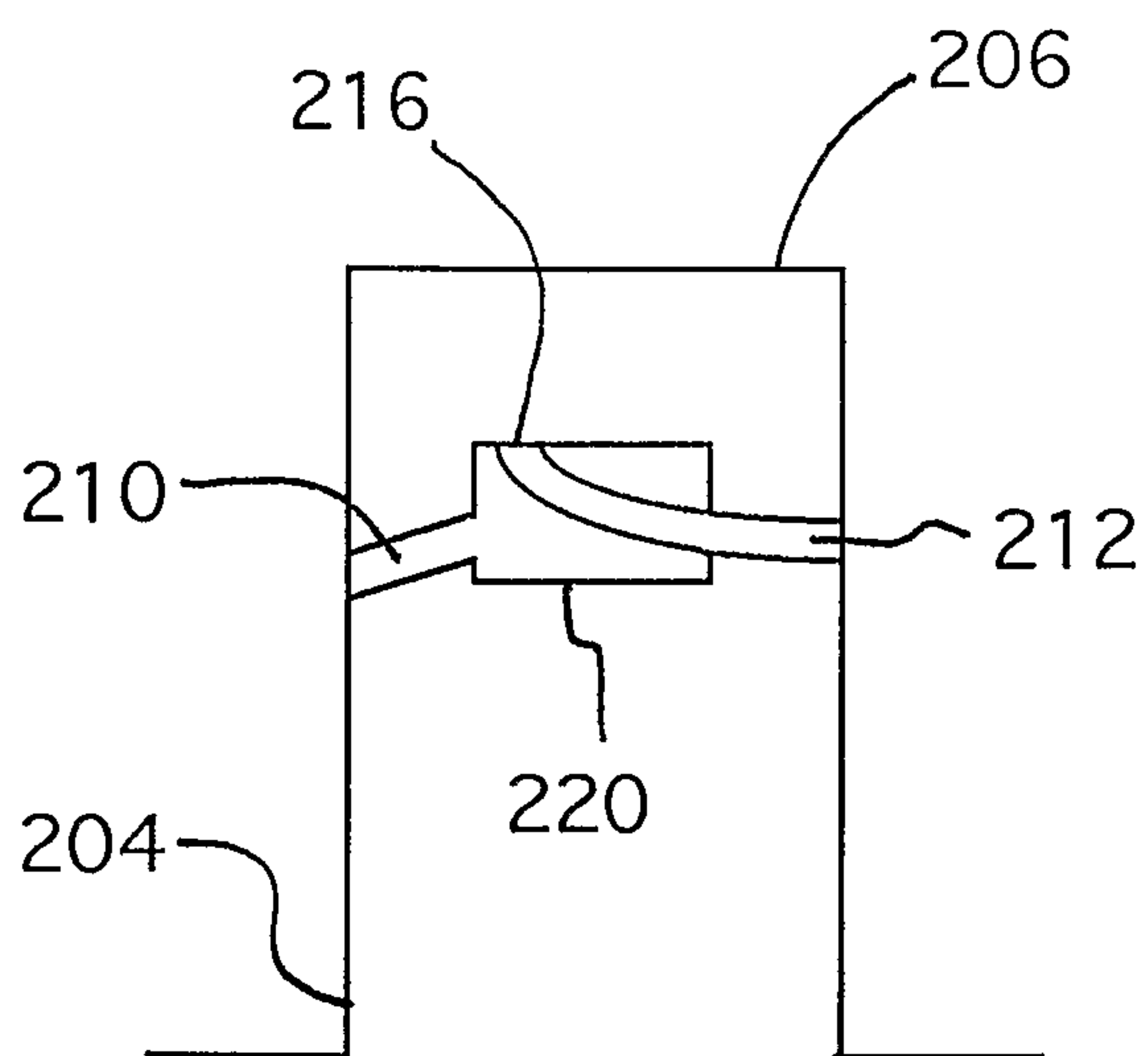

Fig. 11

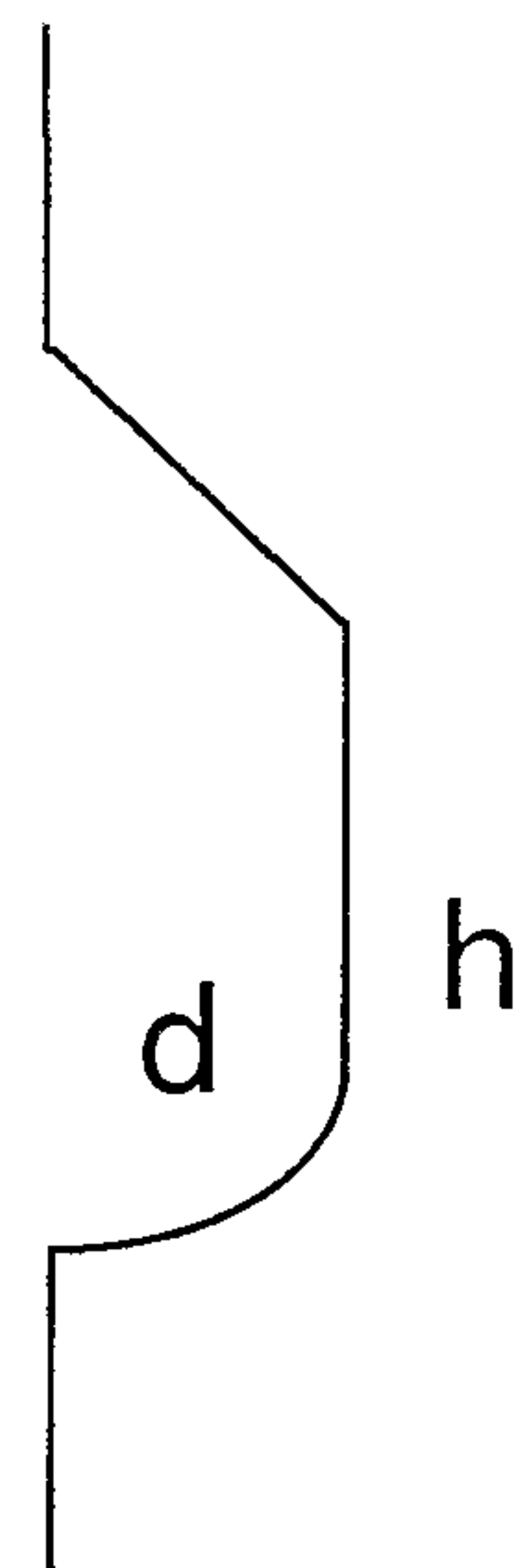

Fig. 12

