

(12) STANDARD PATENT
(19) AUSTRALIAN PATENT OFFICE

(11) Application No. **AU 2010318593 B2**

(54) Title
Structure for an implantable medical device having telemetry and charging coils within a case

(51) International Patent Classification(s)
A61N 1/372 (2006.01) **A61N 1/375** (2006.01)

(21) Application No: **2010318593** (22) Date of Filing: **2010.09.17**

(87) WIPO No: **WO11/059565**

(30) Priority Data

(31) Number	(32) Date	(33) Country
12/616,178	2009.11.11	US

(43) Publication Date: **2011.05.19**

(44) Accepted Journal Date: **2014.05.08**

(71) Applicant(s)
Boston Scientific Neuromodulation Corporation

(72) Inventor(s)
Rahman, Md. Mizanur;Nimmagadda, Kiran;Parramon, Jordi;Feldman, Emanuel

(74) Agent / Attorney
Griffith Hack, GPO Box 1285, Melbourne, VIC, 3001

(56) Related Art
US 2005/0075693

(12) INTERNATIONAL APPLICATION PUBLISHED UNDER THE PATENT COOPERATION TREATY (PCT)

(19) World Intellectual Property Organization
International Bureau



(43) International Publication Date
19 May 2011 (19.05.2011)

(10) International Publication Number
WO 2011/059565 A1

- (51) **International Patent Classification:**
A61N 1/372 (2006.01) A61N 1/375 (2006.01)
- (21) **International Application Number:**
PCT/US2010/049215
- (22) **International Filing Date:**
17 September 2010 (17.09.2010)
- (25) **Filing Language:** English
- (26) **Publication Language:** English
- (30) **Priority Data:**
12/616,178 11 November 2009 (11.11.2009) US
- (71) **Applicant (for all designated States except US):**
BOSTON SCIENTIFIC NEUROMODULATION CORPORATION [US/US]; 25155 Rye Canyon Loop, Valencia, CA 91355 (US).
- (72) **Inventors; and**
- (75) **Inventors/Applicants (for US only):** **RAHMAN, Md. Mizanur** [BD/US]; 25213 Bishop Court, Stevenson Ranch, CA 91381 (US). **NIMMAGADDA, Kiran** [IN/US]; 26127 McBean Parkway, Unit 38, Valencia, CA 91355 (US). **PARRAMON, Jordi** [ES/US]; 27631 Cobblestone Court, Valencia, CA 91354 (US). **FELDMAN, Emanuel** [US/US]; 5785 Nutwood Circle, Simi Valley, CA 93063 (US).
- (74) **Agent:** **LEWIS, Terril, G.;** Wong, Cabello, Lutsch, Rutherford & Bruculeri L.L.P., 20333 Tomball Parkway, Suite 600, Houston, TX 77070 (US).
- (81) **Designated States (unless otherwise indicated, for every kind of national protection available):** AE, AG, AL, AM, AO, AT, AU, AZ, BA, BB, BG, BH, BR, BW, BY, BZ, CA, CH, CL, CN, CO, CR, CU, CZ, DE, DK, DM, DO, DZ, EC, EE, EG, ES, FI, GB, GD, GE, GH, GM, GT, HN, HR, HU, ID, IL, IN, IS, JP, KE, KG, KM, KN, KP, KR, KZ, LA, LC, LK, LR, LS, LT, LU, LY, MA, MD, ME, MG, MK, MN, MW, MX, MY, MZ, NA, NG, NI, NO, NZ, OM, PE, PG, PH, PL, PT, RO, RS, RU, SC, SD, SE, SG, SK, SL, SM, ST, SV, SY, TH, TJ, TM, TN, TR, TT, TZ, UA, UG, US, UZ, VC, VN, ZA, ZM, ZW.
- (84) **Designated States (unless otherwise indicated, for every kind of regional protection available):** ARIPO (BW, GH, GM, KE, LR, LS, MW, MZ, NA, SD, SL, SZ, TZ, UG, ZM, ZW), Eurasian (AM, AZ, BY, KG, KZ, MD, RU, TJ, TM), European (AL, AT, BE, BG, CH, CY, CZ, DE, DK, EE, ES, FI, FR, GB, GR, HR, HU, IE, IS, IT, LT, LU, LV, MC, MK, MT, NL, NO, PL, PT, RO, SE, SI, SK, SM, TR), OAPI (BF, BJ, CF, CG, CI, CM, GA, GN, GQ, GW, ML, MR, NE, SN, TD, TG).
- Declarations under Rule 4.17:**
- as to applicant's entitlement to apply for and be granted a patent (Rule 4.17(ii))
 - as to the applicant's entitlement to claim the priority of the earlier application (Rule 4.17(iii))
- Published:**
- with international search report (Art. 21(3))
 - with amended claims (Art. 19(1))

(54) **Title:** STRUCTURE FOR AN IMPLANTABLE MEDICAL DEVICE HAVING TELEMETRY AND CHARGING COILS WITHIN A CASE

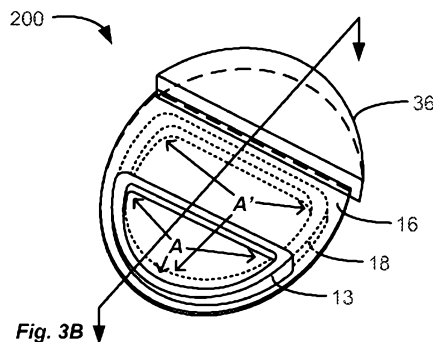

Figure 3A

(57) **Abstract:** An implantable medical device is disclosed comprising a conductive case; a charging coil within the case for receiving power from an external charger, the charging coil wound around an area having a first extent; and a telemetry coil within the case for receiving data from an external controller, or for transmitting data to the external controller, or for receiving and transmitting data from and to the external controller, the telemetry coil would around an area having a second extent, in which the second extent of the telemetry coil at least overlaps the first extent of the charging coil. The charging coil can be proximate to one side of a circuit board, with the telemetry coil is proximate to the other side. The implantable medical device further comprises a non-conductive header comprising at least one lead connector for coupling to an electrode lead.

WO 2011/059565 A1

STRUCTURE FOR AN IMPLANTABLE MEDICAL DEVICE HAVING TELEMETRY AND CHARGING COILS WITHIN A CASE

CROSS REFERENCE TO RELATED APPLICATIONS

[001] This patent application claims priority to U.S. Patent Application Serial No. 12/616,178, filed November 11, 2009, which is incorporated herein by reference in its entirety.

FIELD OF THE INVENTION

[002] The present invention relates to an implantable medical device having charging and telemetry coils within the case of the implantable medical device.

BACKGROUND

[003] Implantable stimulation devices are devices that generate and deliver electrical stimuli to body nerves and tissues for the therapy of various biological disorders, such as pacemakers to treat cardiac arrhythmia, defibrillators to treat cardiac fibrillation, cochlear stimulators to treat deafness, retinal stimulators to treat blindness, muscle stimulators to produce coordinated limb movement, spinal cord stimulators to treat chronic pain, cortical and deep brain stimulators to treat motor and psychological disorders, and other neural stimulators to treat urinary incontinence, sleep apnea, shoulder subluxation, etc. The description that follows will generally focus on the use of the invention within a Spinal Cord Stimulation (SCS) system, such as that disclosed in U.S. Patent 6,516,227. However, the present invention may find applicability in any implantable medical device system.

[004] As shown in Figures 1A and 1B, a SCS system typically includes an Implantable Pulse Generator (IPG) 100, which includes a biocompatible device case 30 formed of a conductive material such as titanium for example. The case 30 typically holds the circuitry and battery 26 necessary for the IPG to function, although IPGs can also be powered via external RF energy and without a battery. The IPG 100 is coupled to electrodes 106 via one or more electrode leads (two

such leads 102 and 104 are shown), such that the electrodes 106 form an electrode array 110. The electrodes 106 are carried on a flexible body 108, which also houses the individual signal wires 112 and 114 coupled to each electrode. In the illustrated embodiment, there are eight electrodes on lead 102, labeled E₁-E₈, and eight electrodes on lead 104, labeled E₉-E₁₆, although the number of leads and electrodes is application specific and therefore can vary. The leads 102, 104 couple to the IPG 100 using lead connectors 38a and 38b, which are fixed in a non-conductive header material 36, which can comprise an epoxy for example.

[005] As shown in Figure 2, the IPG 100 typically includes an electronic substrate assembly 14 including a printed circuit board (PCB) 16, along with various electronic components 20, such as microprocessors, integrated circuits, and capacitors mounted to the PCB 16. Two coils (more generally, antennas) are generally present in the IPG 100: a telemetry coil 13 used to transmit/receive data to/from an external controller 12; and a charging coil 18 for charging or recharging the IPG's battery 26 using an external charger 50. The telemetry coil 13 is typically mounted within the header 36 of the IPG 100 as shown, and may be wrapped around a ferrite core 13'.

[006] As just noted, an external controller 12, such as a hand-held programmer or a clinician's programmer, is used to wirelessly send data to and receive data from the IPG 100. For example, the external controller 12 can send programming data to the IPG 100 to dictate the therapy the IPG 100 will provide to the patient. Also, the external controller 12 can act as a receiver of data from the IPG 100, such as various data reporting on the IPG's status. The external controller 12, like the IPG 100, also contains a PCB 70 on which electronic components 72 are placed to control operation of the external controller 12. A user interface 74 similar to that used for a computer, cell phone, or other hand held electronic device, and including touchable buttons and a display for example, allows a patient or clinician to operate the external controller 12. The communication of data to and from the external controller 12 is enabled by a coil (antenna) 17.

[007] The external charger 50, also typically a hand-held device, is used to wirelessly convey power to the IPG 100, which power can be used to recharge the IPG's battery 26. The transfer of power from the external charger 50 is enabled

by a coil (antenna) 17'. For the purpose of the basic explanation here, the external charger 50 is depicted as having a similar construction to the external controller 12, but in reality they will differ in accordance with their functionalities as one skilled in the art will appreciate.

[008] Wireless data telemetry and power transfer between the external devices 12 and 50 and the IPG 100 takes place via inductive coupling, and specifically magnetic inductive coupling. To implement such functionality, both the IPG 100 and the external devices 12 and 50 have coils which act together as a pair. In case of the external controller 12, the relevant pair of coils comprises coil 17 from the controller and coil 13 from the IPG. In case of the external charger 50, the relevant pair of coils comprises coil 17' from the charger and coil 18 from the IPG.

[009] When data is to be sent from the external controller 12 to the IPG 100 for example, coil 17 is energized with an alternating current (AC). Such energizing of the coil 17 to transfer data can occur using a Frequency Shift Keying (FSK) protocol for example, such as disclosed in U.S. Patent Application Serial No. 11/780,369, filed July 19, 2007. Energizing the coil 17 produces a magnetic field, which in turn induces a voltage in the IPG's coil 13, which produces a corresponding current signal when provided a closed loop path. This voltage and/or current signal can then be demodulated to recover the original data. Transmitting data from the IPG 100 to the external controller 12 occurs in essentially the same manner.

[0010] When power is to be transmitted from the external charger 50 to the IPG 100, coil 17' is again energized with an alternating current. Such energizing is generally of a constant frequency, and may be of a larger magnitude than that used during the transfer of data, but otherwise the basic physics involved are similar.

[0011] The IPG 100 can also communicate data back to the external charger 50 by modulating the impedance of the charging coil 18. This change in impedance is reflected back to coil 17' in the external charger 50, which demodulates the reflection to recover the transmitted data. This means of transmitting data from the IPG 100 to the external charger 50 is known as Load Shift Keying (LSK), and is useful to communicate data relevant during charging of the battery 26 in the

IPG 100, such as the capacity of the battery, whether charging is complete and the external charger can cease, and other pertinent charging variables. LSK communication from an IPG 100 to an external charger is discussed further in U.S. Patent Application Serial No. 12/354,406, filed January 15, 2009.

[0012] As is well known, inductive transmission of data or power can occur transcutaneously, i.e., through the patient's tissue 25, making it particularly useful in a medical implantable device system. During the transmission of data or power, the coils 17 and 13, or 17' and 18, preferably lie in planes that are parallel, along collinear axes, and with the coils as close as possible to each other. Such an orientation between the coils 17 and 13 will generally improve the coupling between them, but deviation from ideal orientations can still result in suitably reliable data or power transfer.

[0013] The inventors consider certain aspects of the design of IPG 100 to be non-optimal. For one, the inventors find it unfortunate that the telemetry coil 13 resides in the IPG's header 36. The telemetry coil 13 takes up space in the header, which space is becoming more limited at IPG technology advances. It is desirable for patient comfort to continue to make IPGs 100 smaller, which shrinks header 36 volume accordingly. At the same time, future-generation IPGs are expected to offer even greater numbers of electrodes (e.g., 32, 64, etc). But accommodating an increased number of electrodes requires more space for lead connectors (see Figs. 1A & 1B; 38a & 38b) in the header 36. As such, it is anticipated by the inventors that there may be little room left in the header for an adequate telemetry coil 13.

SUMMARY OF THE INVENTION

[0014] In a broad aspect the invention provides an implantable medical device, comprising:

- a case;
 - a charging coil within the case configured to wirelessly receive power, wherein the charging coil is wound in a first plane around a first area;
 - and
 - a telemetry coil within the case configured to wirelessly receive data, or wirelessly transmit data, or wirelessly receive and transmit data, wherein the telemetry coil is wound in a second plane around a second area,
- wherein the first and second planes are parallel, and wherein the second area of the telemetry coil at least overlaps the first area of the charging coil, and

wherein the second area is smaller than the first area.

BRIEF DESCRIPTION OF THE DRAWINGS

[0014a] In order that the invention may be more clearly ascertained, embodiments will now be described, by way of example, with reference to the accompanying drawing, in which:

[0015] Figures 1A and 1B show an implantable medical device, and the manner in which an electrode array is coupled to the IPG in accordance with the prior art.

[0016] Figure 2 shows the relation between the implantable medical device, an external controller, and an external charger.

[0017] Figure 3 shows an improved IPG in accordance with the invention, in which both the telemetry and charging coil are within the IPG case.

[0018] Figure 4 shows a first embodiment of improved telemetry circuitry for the IPG of Figure 3, in which the charging coil is decoupled from the telemetry coil using pre-existing LSK circuitry.

[0019] Figure 5 shows a second embodiment of improved telemetry circuitry for the IPG of Figure 3, which includes discrete decoupling circuitry for decoupling the charging coil from the telemetry coil.

[0020] Figure 6 shows a third embodiment of improved telemetry circuitry for the IPG of Figure 3, which includes discrete decoupling circuitry for decoupling the charging coil from the telemetry coil.

[0021] Figure 7 shows a fourth embodiment of improved telemetry circuitry for the IPG of Figure 3, which includes discrete decoupling circuitry for decoupling the charging coil from the telemetry coil which is not controlled by the IPG's microcontroller.

DETAILED DESCRIPTION

[0022] The description that follows relates to use of the invention within a spinal cord stimulation (SCS) system. However, it is to be understood that the invention is not so limited, and could be used with any type of implantable medical device system.

[0023] The inventors address the problem of reduced header 30 volume by placing the telemetry coil 13 inside the device case 30, as shown in Figures 3A and 3B, which shows the basic mechanical structure of the improved IPG 200. When the telemetry coil 13 is placed inside the case 30, more room is left in the header 36 for the at least one or more lead connectors, such as lead connectors 38a and 38b shown in Figure 3B.

[0024] Because the telemetry coil 13 is placed inside the device case 30, it will be shielded to some extent by the conductive material (e.g., titanium) from which the

case is made. Such shielding attenuates data telemetry between the IPG 100 and the external controller 12, making such communications more difficult and less reliable. To counteract this, the telemetry coil 13 is preferably made to encompass a larger area A, as shown in Figure 3A. This larger area improves coupling, and hence the reliability of data transfer, with the telemetry coil 17 in the external controller 12 (Fig. 2). A larger area also compensates for the lack of a ferrite core within the telemetry coil 13, which is eliminated because of its incompatibility with Magnetic Resonance Imaging (MRI) techniques. As shown, the charging coil 18 is proximate to one side of the circuit board 16, with the telemetry coil 13 proximate to the other side of the circuit board 16.

[0025] The charging coil 18 already present inside the device case 30 will interfere with the larger telemetry coil 13, and vice versa. To maximize power receipt from the external charger 50, the charging coil 18 is preferably made as large as possible inside the case 30, with the result that the area extent A encompassed by the telemetry coil 13 is, at least in part, overlapping or entirely within the area extent A' encompassed by the charging coil 18. As a result, the mutual inductance (coupling) between these two coils 13 and 18 is relatively high. This means that the coils 13 and 18 will load each other, which affects receipt of power or data at either coil. Of particular concern is interference of the charging coil 18 when data is being received at or transmitted by the telemetry coil 13. Because of the relatively high coupling, data received at or transmitted from the telemetry coil 13 will induce an opposing current, I_e , in coil 18. This induced current I_e in coil 18 comprises an unwanted energy sink, which effectively reduces the energy and hence reliability of the data transmission.

[0026] To combat this problem, the improved IPG 200 includes improved telemetry circuitry 202, one example of which is shown in Figure 4. Charging coil 18 and capacitor 203 are shown in parallel, which comprise a resonant tank for receiving power from the external charger 50. This L-C circuit 18/203 is tuned to the frequency of the magnetic charging field output by the external charger 50, which may be 80 kHz or same as the data telemetry frequency as discussed below. Resonance of the L-C circuit in response to the magnetic charging field is sent to charging circuitry 240, which includes a rectifier 242 for

converting the received power to a DC level, and protection circuitry 244 for controlling charging of the IPG battery 26 using the rectified power. In the example of Figure 4, the input from the L-C circuit 18/203 to the charging circuitry 240 is differential, occurring at both ends of the paralleled circuit.

[0027] Also shown in Figure 4 is telemetry coil 13 and capacitor 204, which comprise a resonant tank for receiving data from and transmitting data to the external controller 12. This L-C circuit is tuned to the frequency of the external controller 12, which may be 125 kHz or so. For example, when an FSK protocol is used, the frequency might be 121 kHz for transmission of a logic '0', and 129 kHz for a logic '1'. The L-C circuit 13/204 is coupled to transceiver circuitry 250, which includes a receiver 270 for receiving data from the external controller 12; transmission circuitry 271 for transmitting data back to the external controller 12; and transceiver control circuitry 260 coupled to the IPG 200's microcontroller 250.

[0028] Microcontroller 250 determines when it is appropriate to enable reception or transmission of data from or to the external controller 12 per conventional means, and issues reception and transmission enable signals RX_en or TX_en accordingly. When reception is enabled (RX_en), transceiver control circuitry 260 opens transistors 214 and 216 in transmission circuitry 271, and closes transistors 218 and 220. This connects telemetry coil 13 and capacitor 204 in parallel, with one node of the paralleled circuit being coupled to ground through transistors 218 and 220, and the other node X being input into receiver 270. As one skilled in the art will realize, receiver 270 conditions and demodulates the received signal to ultimately produce a digital received data signal, RX_data, which can be input to the microcontroller 250 for appropriate consideration. When transmission is enabled (TX_en), transceiver control circuitry 260 alternates between opening transistors 214 and 220 and closing transistors 216 and 218, and closing transistors 214 and 220 and opening transistors 216 and 218. This establishes a series connection between telemetry coil 13 and capacitor 204, with the alternating of the transistors switching the polarity of the current passing through the L-C circuit 13/204. The frequency of the alternation of the transistors is set by the data to be transmitted, TX_data, with the frequency set to 121 kHz for

transmission of a logic '0', and 129 kHz for a logic '1', consistent with the above-illustrated FSK protocol.

[0029] As mentioned earlier, a potential problem with the arrangement of Figure 4 is the mutual inductance between the telemetry coil 13 and the charging coil 18, a problem which is exacerbated when these coils are placed in proximity within the IPG case 30. In particular, when data is received at or transmitted from the telemetry coil 13, a current I_e is induced in the closed loop formed by the charging coil 18 and capacitor 203. This induced current I_e can be a significant power drain from the received or transmitted data signal, and so can affect the reliability of data transfer to or from the external controller 12. Moreover, the induced current I_e is enhanced by the somewhat close relationship between the frequency of the data (e.g., approximately 125 kHz) and the frequency at which the charging circuitry is tuned (e.g., 80 kHz).

[0030] In the example of Figure 4, induced current I_e is reduced via novel control of LSK communication circuitry 255, although it bears noting that other embodiments to be discussed later remove or reduce I_e through means independent of the LSK circuitry. Prior to discussing such novel control of the LSK circuitry 255, such circuitry's normal use is discussed.

[0031] As mentioned in the Background, LSK circuitry can be used as a means of telemetering data back to the external charger 50 during charging, i.e., for sending data to the external charger when the charging coil receives power from the external charger. Such data is shown in Figure 4 as LSK_data, which gates transistors 210 and 212. When LSK_data = 1, transistors 210 and 212 are closed, and both ends of the paralleled L-C circuit 18/203 are shorted to ground. This modulates the load of the charging coil 18, causing reflections sensed at the external charger 50. The external charger 50 can then demodulate these reflections to recover the serial stream of LSK-transmitted data, as discussed previously.

[0032] In a traditional implementation, LSK circuitry 255 is disabled when the IPG is communicating with the external controller 12. That is, when microcontroller 250 asserts TX_en or RX_en, it disables LSK_data, which turns off transistors 210 and 212. This was logical in prior IPG implementations,

because LSK circuitry 255 was only used for back telemetry to an external charger 50 during charging, and otherwise had no purpose or use during data telemetry with the external controller 12. Additionally, disabling of the LSK circuitry 255 in prior implementations was non-problematic because the telemetry coil 13 and charging coil 18 were not in proximity, and hence were relatively poorly coupled (see, e.g., Fig. 2).

[0033] By contrast, in the improved IPG 200, the LSK circuitry 255 is enabled during communications with the external controller 12 to mitigate the mutual inductance between the telemetry coil 13 and the charging coil 18. As already noted, mutual induction during data telemetry results in an induced current I_e in the charging coil 18 through the tuning capacitor 203, which siphons energy from telemetry—a problem exacerbated by the close proximity of the coils 13 and 18 in IPG 200's design (see, e.g., Fig. 3A). To combat this, and as shown in the timing diagrams at the bottom of Figure 4, the LSK_data signal is asserted by the microcontroller 250 during data telemetry with the external controller 12, i.e., whenever TX_en or RX_en is asserted. Assertion of LSK_data, as mentioned before, will turn on transistors 210 and 212, thus grounding both ends of the paralleled L-C circuit 18/203. With both ends of the resonant circuitry grounded in this fashion, I_e in the charging coil 18 is reduced, which minimizes its loading on the telemetry coil 13, and improves the reliability of data transfer between the IPG 100 and the external controller 12.

[0034] How the induced current I_e is reduced can be understood as follows. The tuning capacitor 203 for L-C circuit 18/203 is chosen to create a resonance for the charging frequency (e.g., 80 kHz), which can be a frequency close to (or same) the telemetry frequency (e.g., 125 kHz). Induced current I_e will increase as the charging frequency approaches the telemetry frequency. When the LSK_data signal shorts the tuning capacitor 203, the L-C circuit is detuned to the coil 18's self-resonance frequency, which is usually much higher than the operating frequency. Even though the tuning capacitor 203 and the coil 18 are grounded at both of their ends, a voltage would still be induced across the coil 18 when a data telemetry field is present. However, because of the detuning caused by the shorted capacitor 203, the induced current I_e is significantly reduced. To remove

It is entirely to zero, one needs to open the closed loop formed by the L-C circuit 18/203, which is the approach taken in Figures 5, 6 and 7.

[0035] To summarize, in the improved IPG 200, the LSK_data signal is used to transmit serial data to the external charger 50 during charging, as is typical. Additionally, LSK_data is also used as a control signal to reduce loading of the telemetry coil 13 during data telemetry between the IPG 100 and the external controller 12. Using the preexisting LSK circuitry 255 to provide this benefit requires no change in the telemetry circuitry 202 other than to program the microcontroller 250 to assert LSK_data during periods of data telemetry. Of course, discrete logic gates could also be used to perform this function, and more than one control signal could be provided by the microcontroller 250 to the LSK circuitry 255. In any event, the implementation of the improved telemetry circuitry 202 shown in Figure 4 improves the reliability of telemetry between the external controller 12 and the IPG 100 without substantial circuitry changes.

[0036] Although LSK_data is shown as enabled when transmission or reception are enabled (TX_en; RX_en), it should be understood that LSK_data can also be enabled when data is actually being transmitted from or received at the IPG 100 (e.g., TX_actual; RX_actual), instead of merely when it is enabled and waiting to do so without regard to whether data is actually being communicated.

[0037] Not all implementations of the improved telemetry circuitry 202 require use of the pre-existing LSK circuitry 255, and Figures 5, 6, and 7 show additional implementations in which the LSK circuitry is not implicated (and thus not shown). The example of Figure 5 includes decoupling circuitry 300 comprising two transistors 205 and 206. In this example, the paralleled resonant L-C circuit 18/203 provides only a single, non-differential input to the charging circuitry 240; the other end of the L-C circuit is coupled to ground during charging through transistors 205 and 206 by assertion of a charge control signal (Chrg_cntl=1). The Chrg_cntl control signal can be asserted either when a magnetic charging field is (or is expected to be) present, or simply could otherwise be asserted at all other times not involving data telemetry (i.e., whenever neither TX_en nor RX_en are asserted), as is shown in the timing diagrams at the bottom of Figure 5. Back

telemetry to the external charger 50 during charging may occur by the use of LSK circuitry, although such circuitry is not shown.

[0038] By contrast, during data telemetry with the external controller 12, i.e., when TX_en or RX_en are asserted, the charge control signal is deasserted (Chrg_cntl=0). This opens transistors 205 and 206 which opens the charging coil 18, which removes current flow through the charging coil 18, such that $I_e=0$, realizing the desirable benefits already discussed. Similar to Figure 4, Chrg_cntl can also be deasserted when data is actually being transmitted from or received at the IPG 100 (e.g., TX_actual; RX_actual), instead of merely when it is enabled and waiting to do so.

[0039] Although decoupling circuitry 300 in Figure 5 shows two transistors 205 and 206, it should be understood that only one transistor is needed to interrupt induced current I_e in the loop comprising L-C circuit 18/203.

[0040] The improved telemetry circuitry 202 of Figure 6 also includes decoupling circuitry 300. The L-C circuit 18/203 is coupled in parallel, and provides a differential input to the charging circuitry 240. The decoupling circuitry 300 is connected in series with the coil 18, the decoupling capacitor 203, or both. In the embodiment shown, the decoupling circuitry 300 is shown in series with the coil 18, although the dotted lines show the optional provision of such circuitry in series with capacitor 203.

[0041] In this example, decoupling circuitry 300 can comprise an optical circuit, such as a PhotoMOS switch 301. A suitable PhotoMOS switch 301 for use in the improved telemetry circuitry 301 is manufactured by Panasonic Electric Works, Ltd. part number AQY22100M. A data sheet for this device is submitted with this disclosure via an Information Disclosure Statement. Although familiarity with PhotoMOS switch 301 can be assumed, key internal circuitry within the switch 301 is shown in Figure 6. When the charge control signal is asserted (Chrg_cntl=1), an LED 276 built into the PhotoMOS switch 301 turns on and emits radiation. This radiation is received by two serially-connected photo-sensitive MOS transistors 207 and 208. When illuminated by LED 276, these normally-off transistors 207 and 208 are turned on. In other words, transistors

207 and 208 are normally open, but become a short circuit when illuminated by the LED 276.

[0042] Thus, during charging or periods of no data telemetry ($\text{Chrg_cntl}=1$), the PhotoMOS switch 301 is closed, which couples the L-C circuit 18/203 to the charging circuitry 240 to enable power reception from the external charger 50. When charging is not enabled ($\text{Chrg_cntl}=0$), e.g., when TX_en or RX_en are asserted, the switch 301 is opened, which opens the L-C circuit loop 18/203, which removes induced current flow in charging coil 18 ($I_e=0$), realizing the desirable benefits already discussed. Similar to Figure 5, Chrg_cntl can also be deasserted when data is actually being transmitted from or received at the IPG 100 (e.g., TX_actual ; RX_actual), instead of merely when it is enabled and waiting to do so.

[0043] While the improved telemetry circuitry 202 of Figure 6 features decoupling circuitry 300 using an optical solution, it should be appreciated that more standard solutions include the use of electrically-gated transistors could be used as well.

[0044] The embodiments of the improved telemetry circuit 202 shown so far rely on the provision of at least one control signals (LSK_data , Chrg_cntl) from the IPG's microcontroller 250 to decouple the charging coil 18 from the telemetry coil 13 during data telemetry with the external controller 12. However, this is not strictly required, and the charging circuitry can independently decide when it needs to be coupled or decoupled. For example, in Figure 7, the decoupling circuitry 300 is able to independently detect the presence of the magnetic charging field and can enable the receipt of this power even without receipt of information from the microprocessor 250. For the rest of the time, including the data telemetry operation, the decoupling circuitry 300 disconnects the charge coil 18, thereby removing I_e by making $I_e=0$.

[0045] The improved telemetry circuit 202 of Figure 7 is similar to that shown in Figure 6, but adds a charge field detection circuit 287. The charge field detection circuit comprises an inductor 282 and a capacitor 283 in parallel and coupled to the inputs of the PhotoMOS switch 301. This L-C circuit 287 is tuned by appropriate choice of the values of the capacitor and inductor to resonate at the

same frequency as the magnetic charging field broadcast by the external charger 50—approximately 80 kHz. The upper left corner of Figure 7 shows one possible location for the inductor (coil) 282 used in the charge field detection circuit 287. Notice that coil 282 is preferably outside the area extent of telemetry coil 13 so as to prevent coupling between the two.

[0046] When a magnetic charging field has been broadcast from the external charger 50, L-C circuit 287 will detect this fact and start to resonate. Such resonance will power the diode 276 in the PhotoMOS switch 301 to radiate, which in turn will turn on transistors 207 and 208. Thus, the L-C tank 18/203 is coupled to the charging circuitry 240, and the implant's battery can be charged. By contrast, during other periods—during data telemetry at a different frequency (e.g., 125 kHz) or when no magnetic fields are present at all, L-C circuit 287 will not resonate, LED 276 will not radiate, and transistors 207 and 208 will be off. Importantly, the current I_e induced in the charging coil 18 equals zero during periods of data telemetry. This decouples the telemetry coil 13 from the charging coil 18, realizing the desirable benefits already discussed.

[0047] The disclosed embodiments of improved telemetry circuitry 202 assist in decoupling the telemetry coil 13 and the charging coil 18, which ultimately improves the reliability of data telemetry between the IPG 100 and the external controller 12. Such improved circuitry 202, as noted, is particularly useful when a relatively high coupling exists between the two coils 13 and 18, such as when the two coils are within the same IPG case 30, and encompass areas that are overlapping. However, this does not mean that all useful implementations are limited to these contexts.

[0048] While embodiments to this point have focused on interference of the charging coil 18 during data telemetry, it should be understood that mutual inductance between the charging coil 18 and the telemetry coil 13 can also result in interference of the telemetry coil 13 during charging. Therefore, although not shown, it should be understood that decoupling circuitry 200 could also be employed with telemetry coil 13, with the goal of preventing an induced current in that coil during the reception of a magnetic charging field at charging coil 18. Thus, decoupling circuitry can decouple the charging coil when the telemetry coil

is communicating or enabled to communicate with the external controller, or can decouple the telemetry coil when the charging coil is receiving power or enabled to receive power from the external charger.

[0049] It should be noted that it is unimportant to implementations of the invention whether the IPG 100 functions with separate external devices (external controller 12 and external charger 50) for charging and data telemetry. Instead, a singular external device capable of both data telemetry and production of a charging field could be used. See, e.g., U.S. Patent Application Serial 12/368,385, filed February 10, 2009.

[0050] Although the telemetry coil in the disclosed examples is capable of receiving and transmitting data from and to the external controller, other implementations will require only that the telemetry coil receive data, or that the telemetry coil transmit data. In recognition of this fact, and to cover each of the ideas using simple phrasing, a telemetry coil “receiving and/or transmitting data from and/or to the external controller” comprises a telemetry coil for receiving data from an external controller, or a telemetry coil for transmitting data to the external controller, or a telemetry coil for receiving and transmitting data from and to the external controller.

[0051] Although particular embodiments of the present invention have been shown and described, it should be understood that the above discussion is not intended to limit the present invention to these embodiments. It will be obvious to those skilled in the art that various changes and modifications may be made without departing from the spirit and scope of the present invention. Thus, the present invention is intended to cover alternatives, modifications, and equivalents that may fall within the spirit and scope of the present invention as defined by the claims.

[0052] It is to be understood that, if any prior art is referred to herein, such reference does not constitute an admission that such prior art forms a part of the common general knowledge in the art, in Australia or any other country.

[0053] In the claims that follow and in the preceding description of the invention, except where the context requires otherwise due to express language or necessary implication, the word “comprise” or variations such as “comprises” or “comprising” is used in an inclusive sense, i.e. to specify the presence of the stated features but not to preclude the presence or addition of further features in various embodiments of the invention.

WHAT IS CLAIMED IS:

1. An implantable medical device, comprising:
 - a case;
 - a charging coil within the case configured to wirelessly receive power, wherein the charging coil is wound in a first plane around a first area; and
 - a telemetry coil within the case configured to wirelessly receive data, or wirelessly transmit data, or wirelessly receive and transmit data, wherein the telemetry coil is wound in a second plane around a second area,wherein the first and second planes are parallel, and wherein the second area of the telemetry coil at least overlaps the first area of the charging coil, and wherein the second area is smaller than the first area.
2. The device of claim 1, further comprising a circuit board, wherein the charging coil is proximate to one side of the circuit board, and the telemetry coil is proximate to the other side of the circuit board.
3. The device of either claim 1 or 2, wherein the second area of the telemetry coil is entirely within the first area of the charging coil.
4. The device of any one of claims 1 to 3, wherein the case is conductive.
5. The device of any one of claims 1 to 4, further comprising a header comprising at least one lead connector configured to couple to an electrode lead.
6. The device of claim 5, wherein the header is non-conductive.
7. The device of any one of claims 1 to 6, wherein the telemetry coil is not wound around a ferrite core.

8. The device of any one of claims 1 to 7, further comprising decoupling circuitry controllable to reduce or remove a current in the charging coil when the telemetry coil is receiving or transmitting data.

9. The device of any one of claims 1 to 8, further comprising decoupling circuitry controllable to reduce or remove a current in the charging coil when the telemetry coil is enabled to receive or transmit data.

10. The device of any one of claims 1 to 9, wherein the first and second planes are parallel to first and second sides of the case.

11. The device of any one of claims 1 to 10, further comprising a battery, and charging circuitry coupled between the battery and the charging coil, wherein the charging circuitry uses the received power to charge the battery.

12. The device of claim 11, wherein the battery is inside the charging coil.

13. The device of any one of claims 1 to 12, wherein the charging coil is tuned to a first frequency matching the received power, and wherein the telemetry coil is tuned to a second frequency matching the data.

14. An implantable medical device substantially as herein described with reference to figures 3 to 7 of the accompanying drawings.

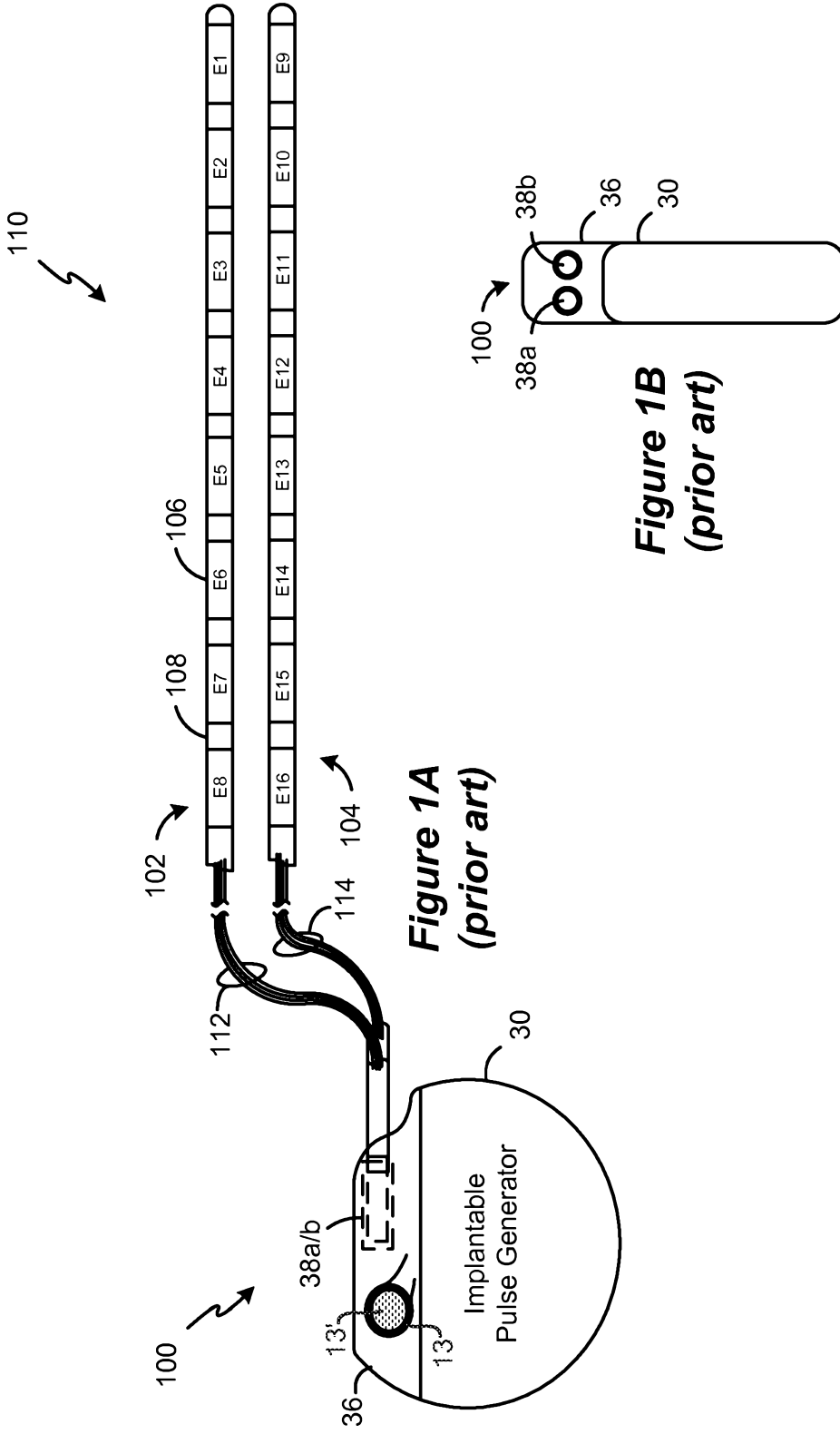

Figure 1A
(prior art)

Figure 1B
(prior art)

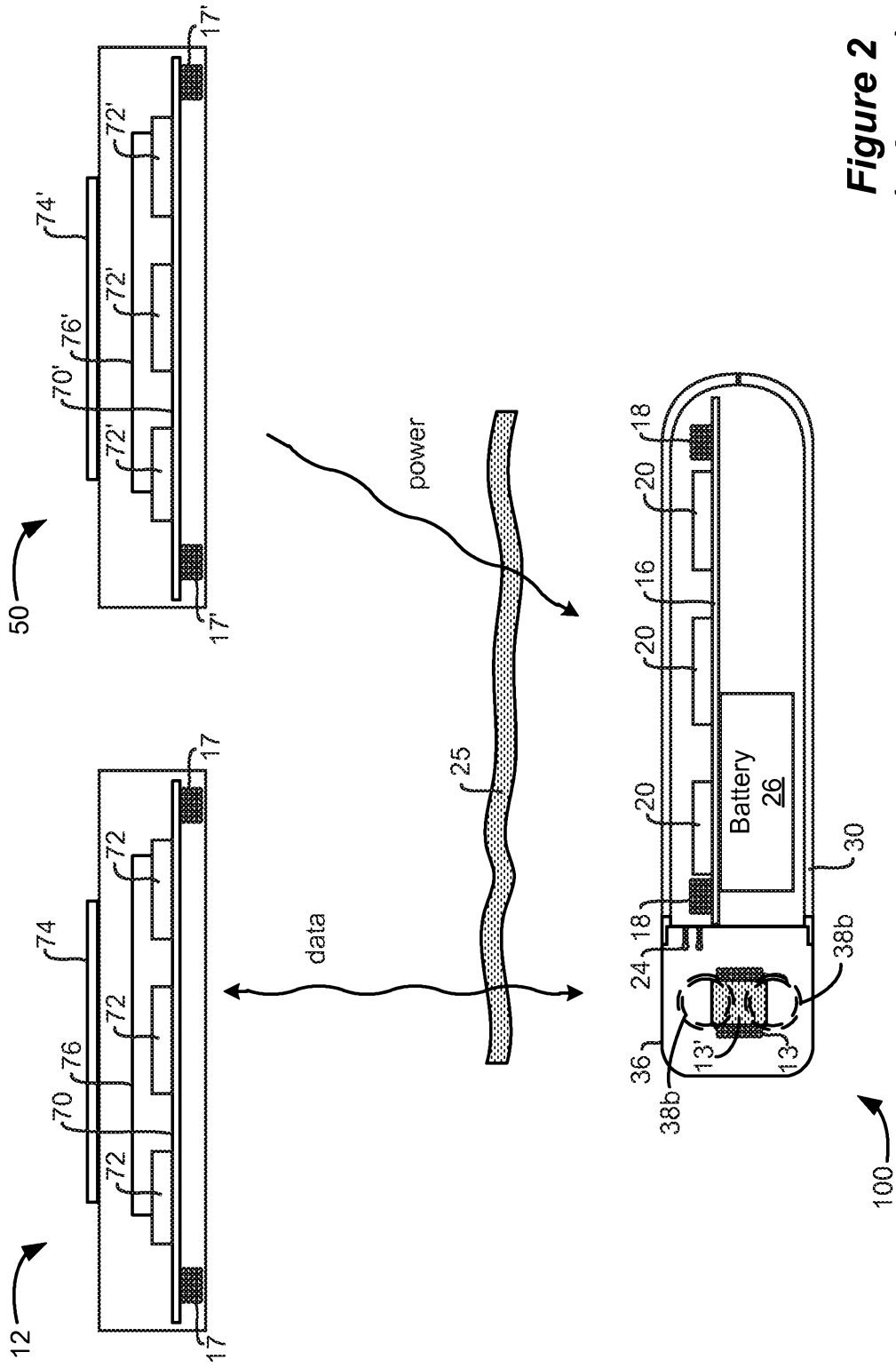

Figure 2
(prior art)

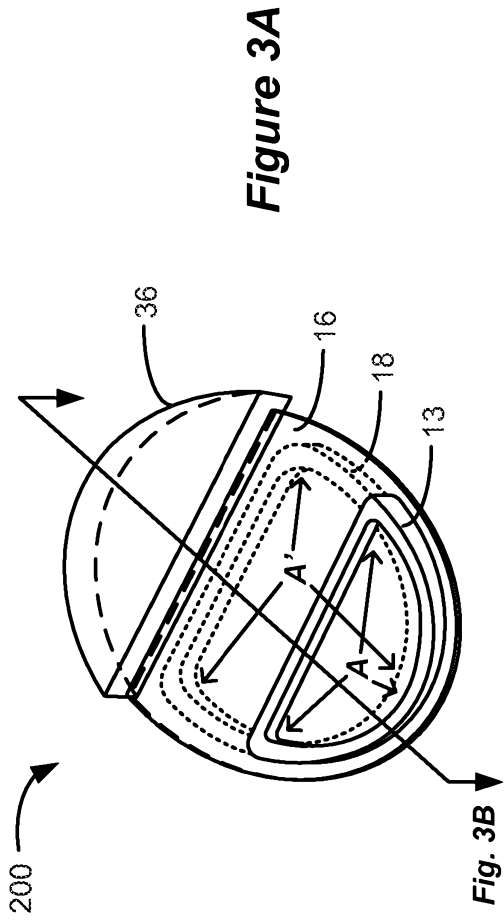

Figure 3A

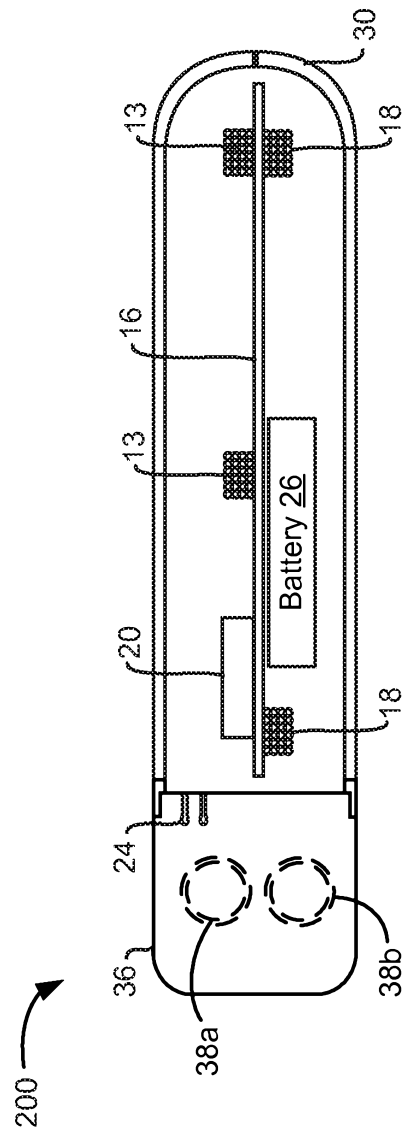

Figure 3B

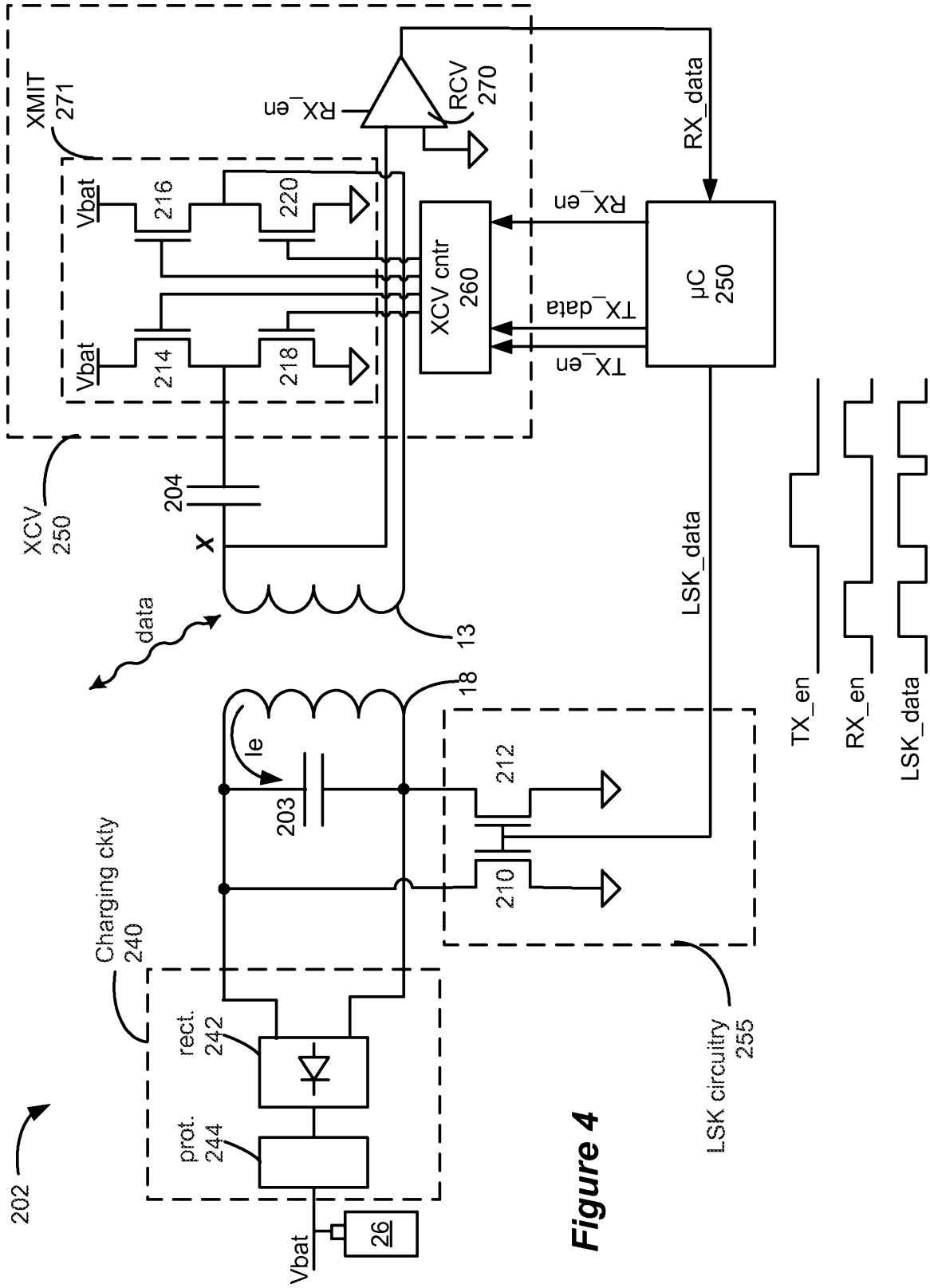

Figure 4

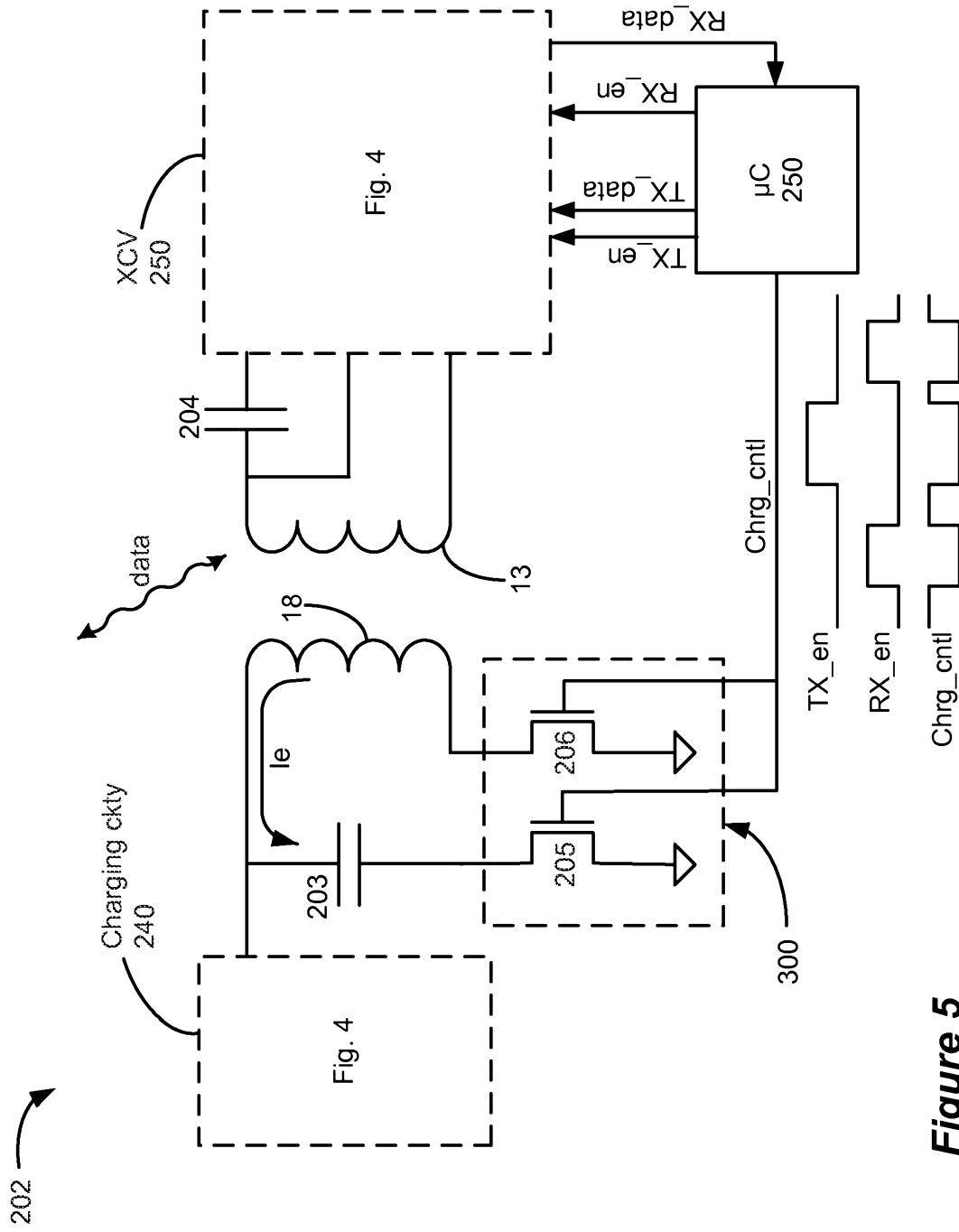

Figure 5

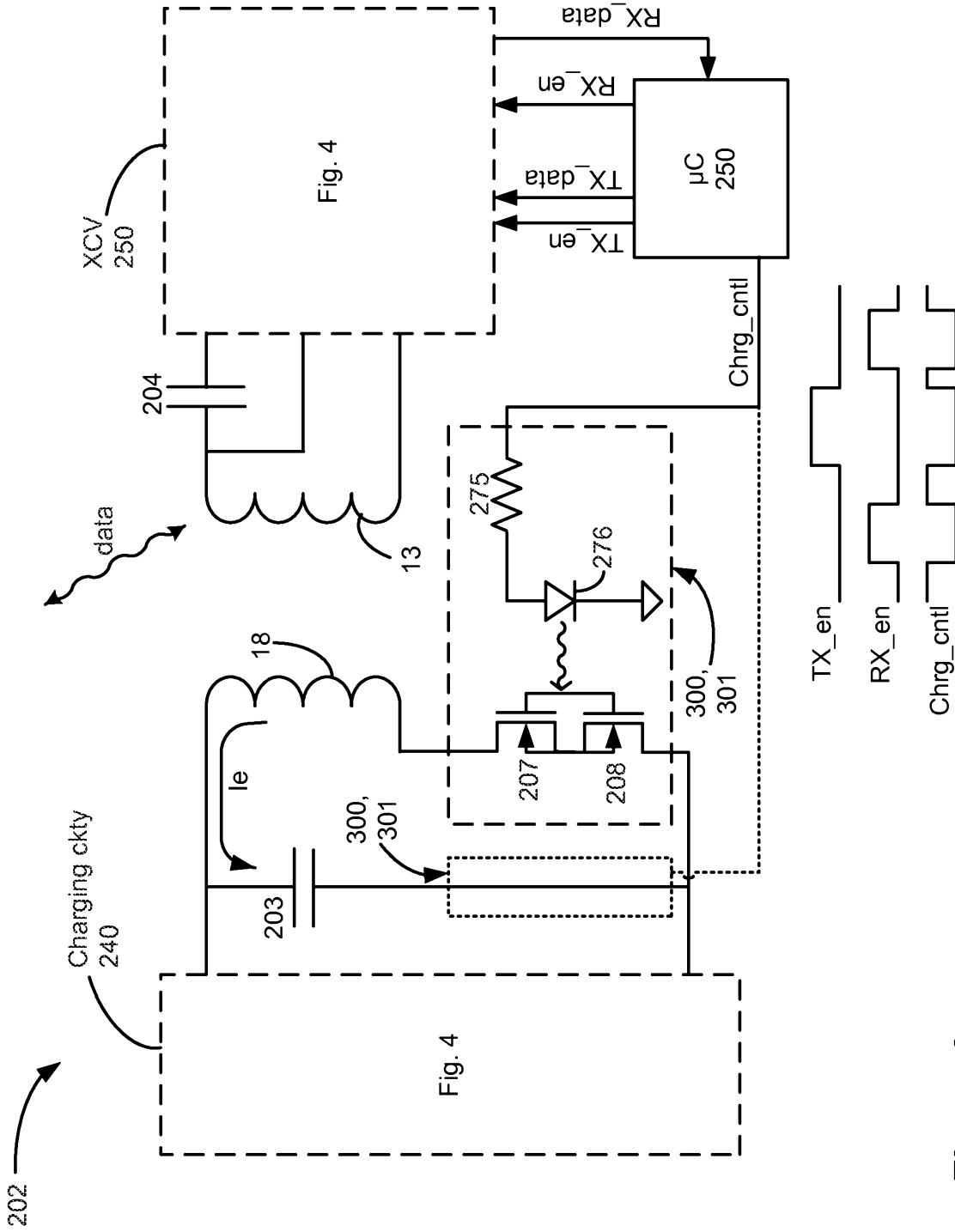

Figure 6

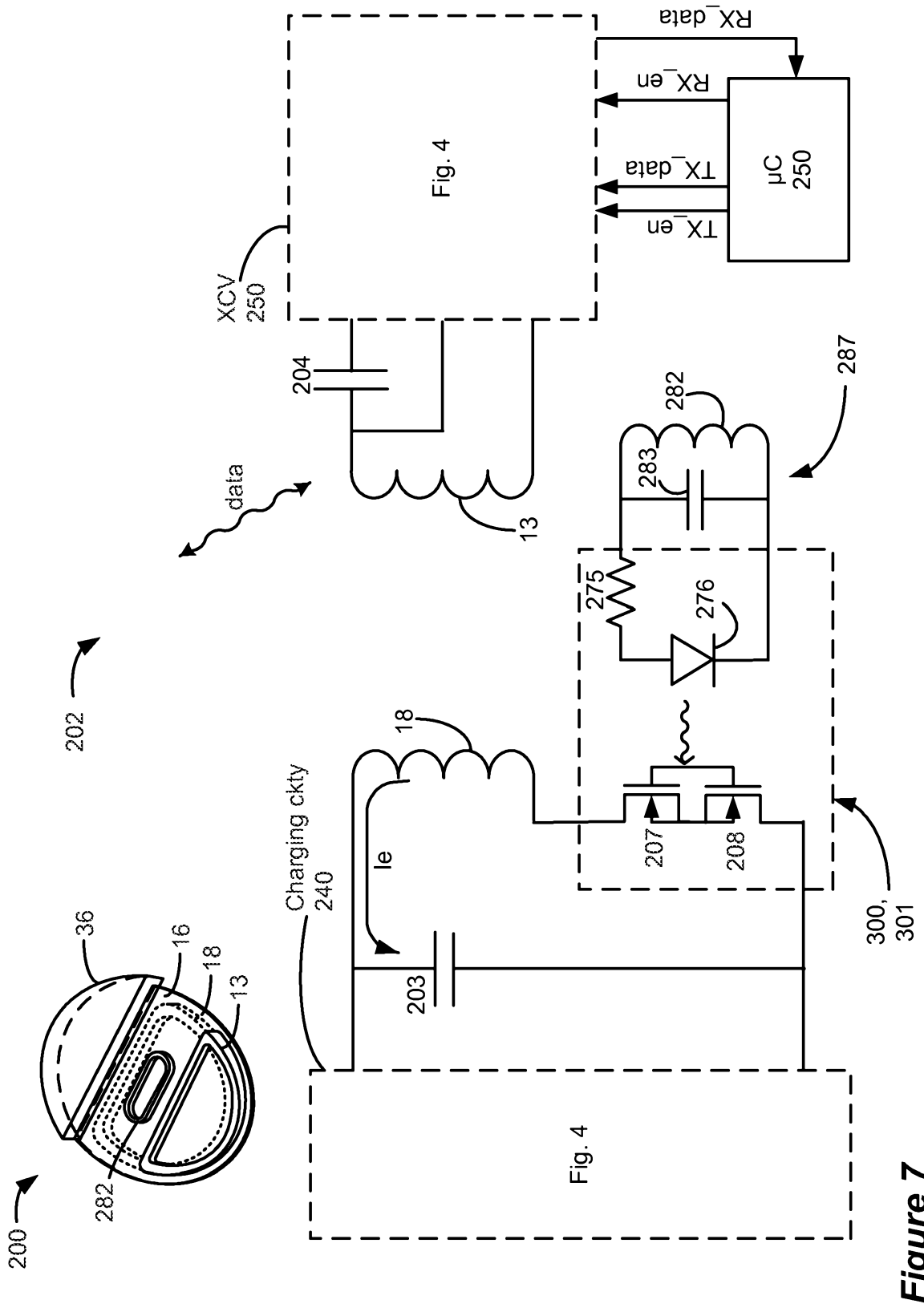

Figure 7