

J. A. HERRICK.  
GAS VALVE.

APPLICATION FILED JUNE 1, 1910.

1,001,399.

Patented Aug. 22, 1911.

6 SHEETS—SHEET 1.

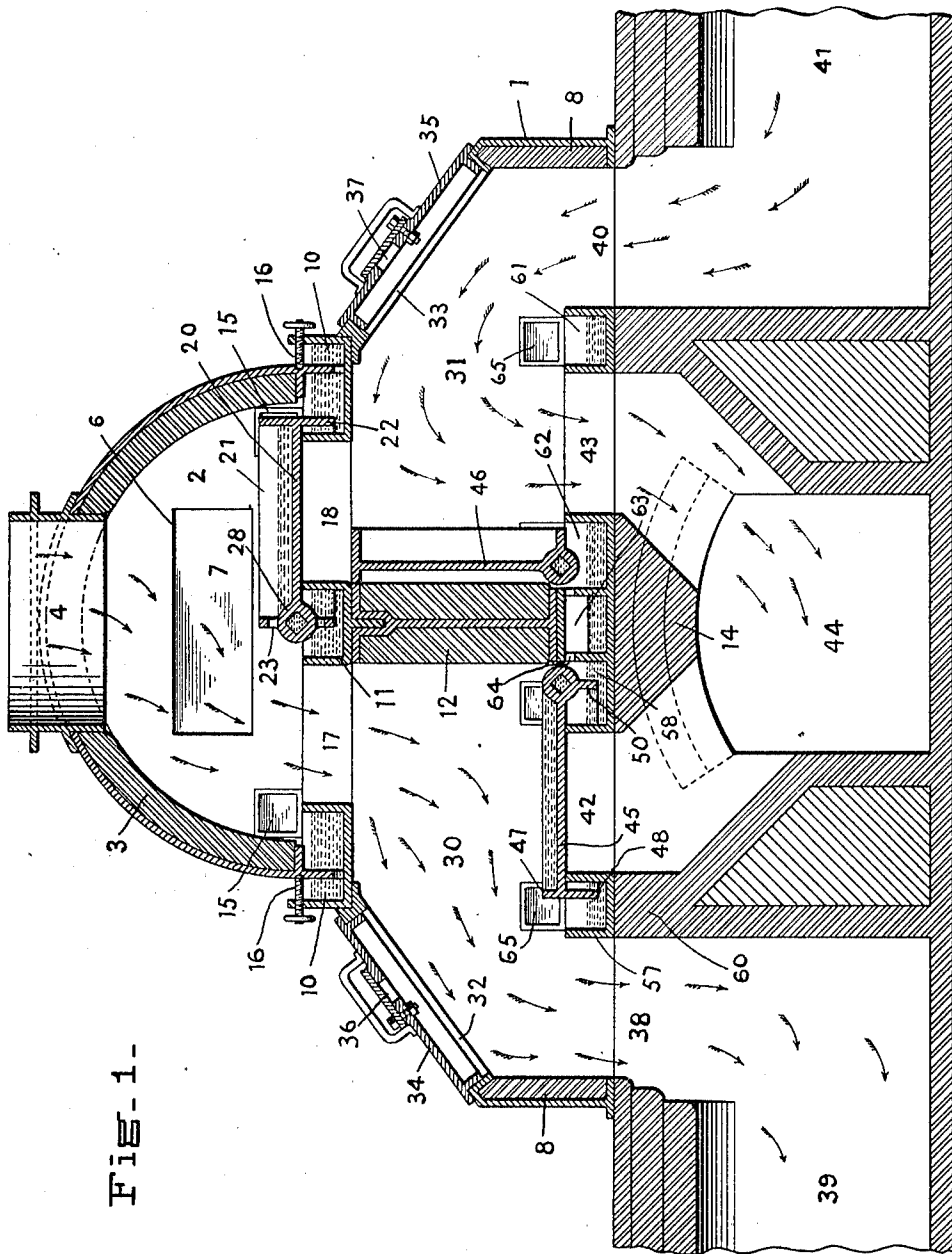

FIG-1-

WITNESSES:

*J. J. J. J.*  
*Adelle Honeysberg*

*James A. Herrick* INVENTOR  
BY *Wilson & Kent*  
ATTORNEYS.

J. A. HERRICK.  
GAS VALVE.  
APPLICATION FILED JUNE 1, 1910.

1,001,399.

Patented Aug. 22, 1911.

5 SHEETS—SHEET 2.

FIG. 2.

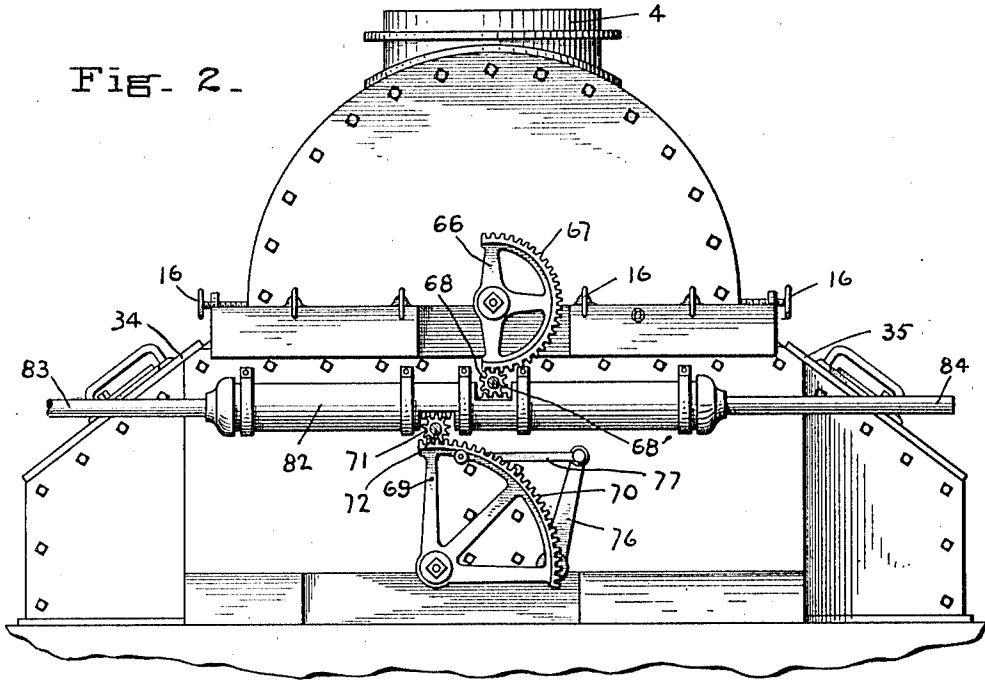
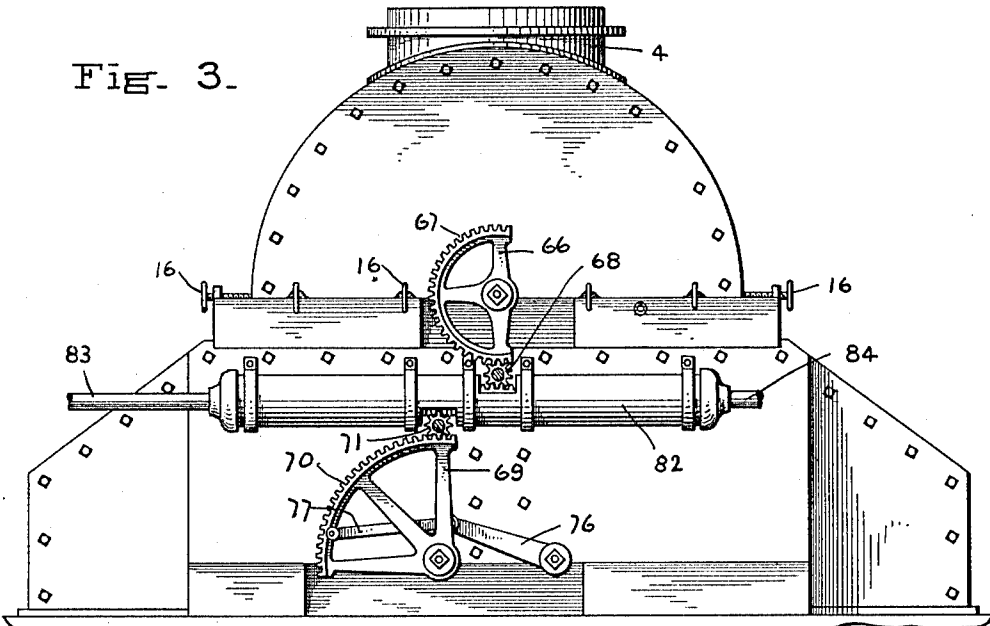

FIG. 3.



WITNESSES:  
*J. P. [Signature]*  
*Adele Horigberg*

INVENTOR  
*James A. Herrick*  
BY  
*Wilson & Kent*  
ATTORNEYS.

J. A. HERRICK.

GAS VALVE.

APPLICATION FILED JUNE 1, 1910.

1,001,399.

Patented Aug. 22, 1911.

5 SHEETS—SHEET 3.

Fig. 4.

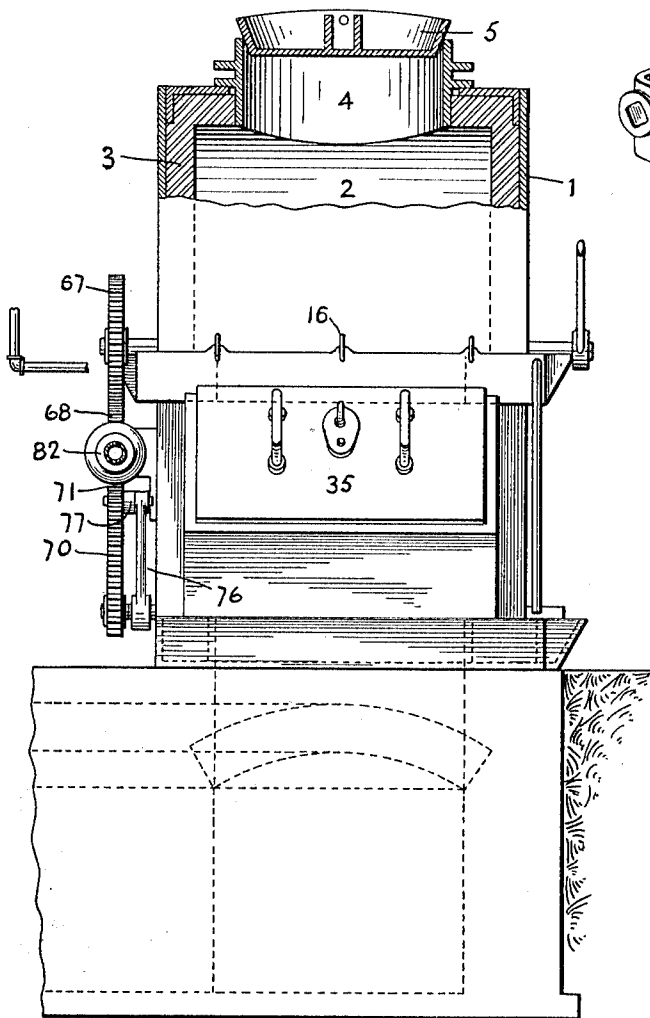

Fig. 5.

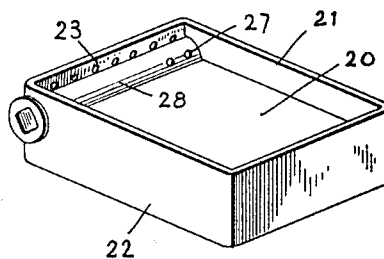

Fig. 6.

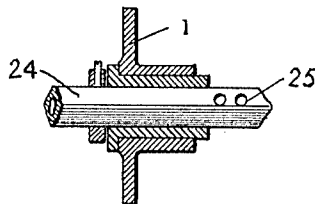

Fig. 8.

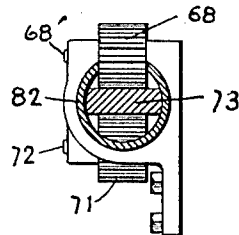
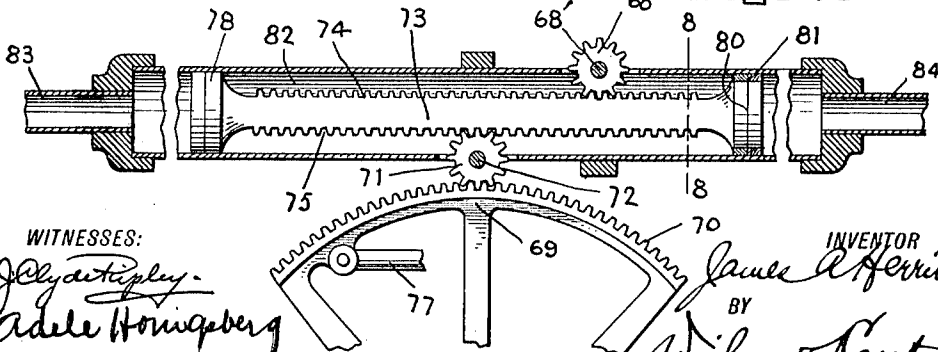

Fig. 7.



WITNESSES:

*J. A. Herrick*  
*Adele Honigberg*

INVENTOR

*James A. Herrick*  
BY  
*Wilson Kent*  
ATTORNEYS.

J. A. HERRICK.  
 GAS VALVE.  
 APPLICATION FILED JUNE 1, 1910.

1,001,399.

Patented Aug. 22, 1911.  
 5 SHEETS—SHEET 4.

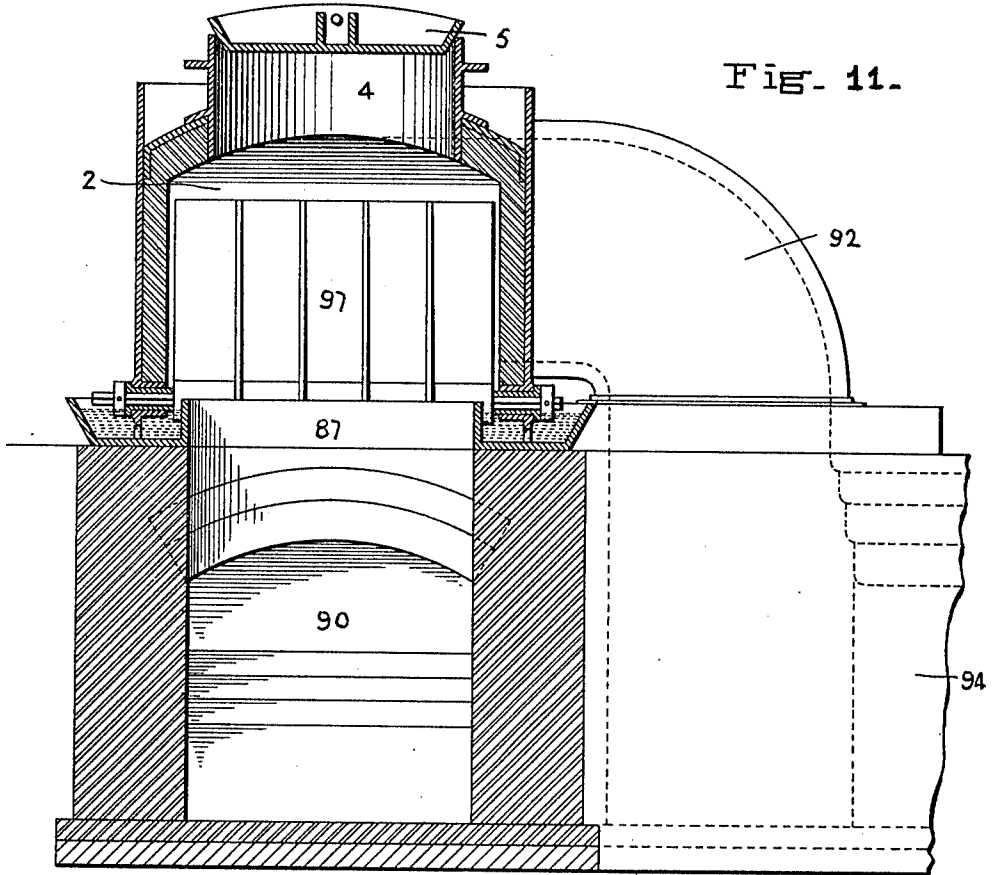
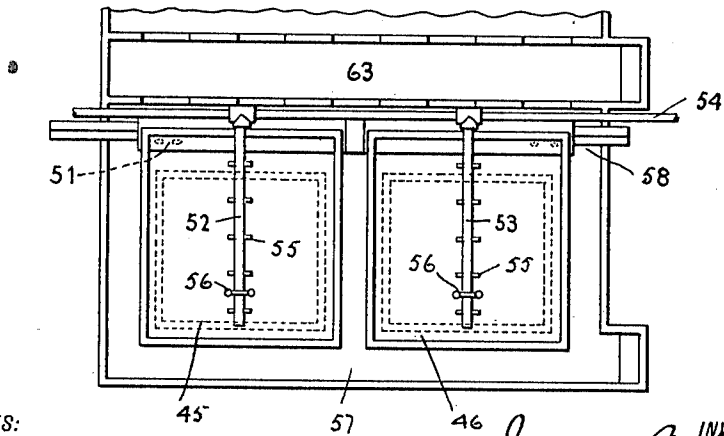

Fig. 9.



WITNESSES:  
*J. J. [Signature]*  
*Adelle Housberg*

INVENTOR  
*James A. Herrick*  
 BY  
*Wilson & Kent*  
 ATTORNEYS!

J. A. HERRICK.

GAS VALVE.

APPLICATION FILED JUNE 1, 1910.

1,001,399.

Patented Aug. 22, 1911.

5 SHEETS—SHEET 6.

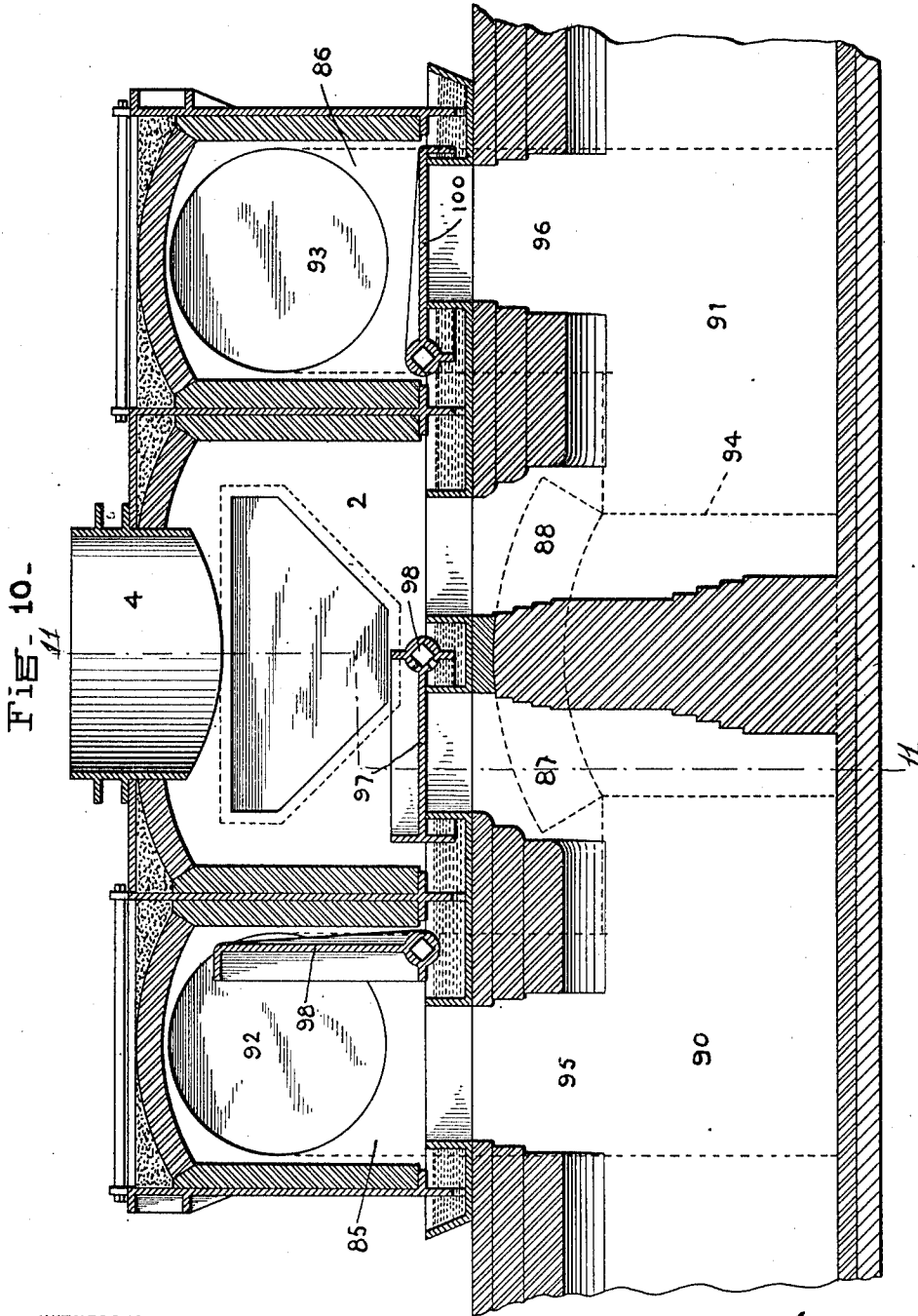

WITNESSES:  
*J. J. DePuy.*  
*Adelle Honeopberg*

INVENTOR  
*James A. Herrick*  
BY  
*Wilson & Hunt*  
ATTORNEYS.

# UNITED STATES PATENT OFFICE.

JAMES A. HERRICK, OF NEW YORK, N. Y.

GAS-VALVE.

1,001,399.

Specification of Letters Patent. Patented Aug. 22, 1911.

Application filed June 1, 1910. Serial No. 564,447.

*To all whom it may concern:*

Be it known that I, JAMES A. HERRICK, residing at New York, in the county and State of New York, have invented certain new and useful Improvements in Gas-Valves, of which the following is a specification.

This invention relates to producer gas apparatus, and one of the objects of the invention is to provide new and improved valve mechanism adapted to be used in connection with gas producing and gas consuming apparatus.

Another object is to provide improved means whereby the valve mechanism in such apparatus may be kept in a cool condition at all times and thereby prevented from becoming burned out.

Another object is to provide valve mechanism such that the gas consuming apparatus is at all times in direct communication with the stack, and the gas supplying means is also in direct communication with the gas consuming apparatus thereby insuring a ready and unobstructed feed of producer gas, and a free discharge of the products of combustion.

Another object of the invention is to so construct the valve mechanism that a ready access may be had to all the interior parts whereby replacement or renewal of parts may be easily and expeditiously effected.

Other objects will be in part obvious and in part pointed out hereinafter.

The invention accordingly consists in the features of construction, combinations of elements and arrangement of parts, which will be exemplified in the construction hereinafter described, and the scope of the application of which will be indicated in the following claims.

In the accompanying drawings wherein I have illustrated two forms of embodiments of my invention: Figure 1 is a view in vertical section of a preferred embodiment thereof, showing the arrangement of the interior of the valve mechanism; Fig. 2 is a view in side elevation showing the means for operating the valve in one position; Fig. 3 is a view similar to Fig. 2, but showing the parts in a different position; Fig. 4 is a view in end elevation, partly broken away; Fig. 5 is a view in perspective of one of the valves; Fig. 6 is a sectional view showing the manner of conducting water to the

valve; Fig. 7 is a sectional view through the casing or cylinder of the valve operating mechanism; Fig. 8 is a vertical sectional view taken substantially on the line 8—8 of Fig. 7; Fig. 9 is a plan view showing one of the valves and the manner in which the same is mounted within the casing; Fig. 10 is a vertical sectional view showing a slightly modified embodiment of my invention; and Fig. 11 is a view in vertical section on line 11—11 of the structure shown in Fig. 10.

Similar reference characters refer to similar parts throughout the several views of the drawings.

Referring now to the drawings, and particularly to the embodiment of my invention shown in Figs. 1 to 9 inclusive, 1 denotes generally the metallic casing of my improved valve mechanism, in the upper part of which is formed a valve chamber 2, which is preferably lined with a heat resisting material such as shown at 3. Leading into this valve chamber is a conduit 4, which may be valved as by means of the valve 5, Fig. 4. This conduit leads from a source of gas supply, not shown, as for instance, from gas producing apparatus. Valve chamber 2 may be provided with an opening 6, through which access may be had to the interior, which opening may be suitably closed as by means of a door 7, held in position in any desirable manner.

Suitably supported upon the side walls 8 and end walls of the casing, are troughs 10, and 11 indicates a central trough supported upon the upright 12 which is disposed transversely of the casing, and which in turn is supported by the arch 14. These troughs are adapted to contain water which is discharged thereinto by means presently to be described.

15 indicates openings provided in the casing which may be employed as observation openings, or through which access may be had to the interior of the valve-chamber 2, when it is desired to clean out the troughs 10. The outer wall of the valve-chamber 12 rests in the troughs 10, and provision is made whereby a slight lateral adjustment of the chamber may be had and by means of the adjusting screws 16, which are threaded into the outer wall of the troughs. The lower edges of the metallic casing of valve chamber 2 may be cut away, as shown,

below the water line so as to provide for a free access of water to all parts of the trough.

5 Leading from valve-chamber 2 are pas-  
 10 sage ways 17 and 18 and adapted alter-  
 15 nately to open and close these passage ways  
 20 is a valve member 20, which is suitably piv-  
 25 oted upon a hollow shaft immediately above  
 30 trough 14. Valve member 20 is provided  
 35 with oppositely extending flanges 21 and 22,  
 40 so that a receptacle adapted for containing  
 45 water is provided on the upper and lower  
 50 side of the valve member, the flanges adja-  
 55 cent the pivotal portion of the valve mem-  
 60 ber being provided with openings as at 23,  
 65 through which water may flow to the trough  
 11, when the valve member is swung from  
 one side to the other by the means which  
 will presently be described. The shaft 24  
 which forms a hollow pivot for the valve  
 member 20 is provided with two sets of op-  
 posed openings, as at 25, and one of these  
 sets is adapted to register with the openings  
 27 formed in the collar 28, formed integral  
 with the valve-member and which encircles  
 the pipe upon which it swings, when the  
 valve member is in one position, for in-  
 stance, as that shown in the drawing where-  
 by water may be discharged through the hol-  
 low pivotal portion to the upper portion of  
 the valve. These openings are closed when  
 the valve member is swung to the opposite  
 position to close the passage way 17 and the  
 openings opposite are carried into engage-  
 ment with another set of openings in the  
 pipe 24, whereby water may be discharged  
 upon the opposite side of the valve member.  
 The flanges 21 and 22 when the valve mem-  
 ber is in either of its closed positions, dip  
 into the troughs 10 and 11 and form a water-  
 seal for the passage ways 17 and 18.

Passage ways 17 and 18 lead into valve-  
 chambers 30 and 31 respectively, which are  
 also provided with suitably closed openings  
 32 and 33, doors 34 and 35 being provided in  
 the present instance, and these doors 34 and  
 35 may be provided with suitably closed  
 sight openings 36, 37. Leading from valve-  
 chamber 30 is a passage way 38 which leads  
 to a conduit 39, and leading from valve-  
 chamber 31 is a passage way 40, which leads  
 to a conduit 41. Conduits 39 and 41 are con-  
 nected with a furnace or other gas consum-  
 ing apparatus, not shown, and it will be un-  
 derstood that each of these conduits is  
 adapted alternately to conduct gas to the gas  
 consuming apparatus, or to conduct the  
 products of combustion therefrom; it being  
 understood that when one of the conduits is  
 conducting gas to the gas consuming appara-  
 tus, the other is discharging the products of  
 combustion into a stack, as will be presently  
 described. Leading also from valve-cham-  
 bers 30 and 31 are passage ways 42 and 43  
 respectively, which lead into a stack, the

flue of which is shown at 44. Passage ways  
 42 and 43 are adapted to be closed as by  
 means of valves 45 and 46, and inasmuch as  
 these valves are similar in all respects, but  
 one thereof need be described herein. Re-  
 70 ferring now to valve 45, the same consists of  
 a metallic sheet provided with opposed  
 flanges 47 and 48, and a downward extend-  
 75 ing flange 50. The inner end of the valve  
 is formed hollow and is adapted to receive  
 a pipe upon which the same swings, said  
 pipe being provided with suitable openings  
 which register with openings as at 51, and  
 80 through which water may be discharged  
 upon the top of the valve, it being under-  
 stood that when the valve is in upright posi-  
 tion, the openings are carried out of register  
 thereby shutting off the flow of water.  
 Water may also be discharged on top of  
 the valve as by means of journaled pipes 52  
 85 and 53 mounted upon a transversely extend-  
 ing supply pipe 54, the construction being  
 such that when the valves are in a vertical  
 position, water will be discharged through  
 the pipes 52 and 53 by means of the small  
 90 nozzles 55, carried by said pipes; this result  
 being attained by means of forming valves  
 at the points where the pipes 52 and 53 are  
 connected with the pipe 54, so that when  
 pipes 52 and 53 are vertical the supply of  
 95 water is turned on, and when they are hori-  
 zontal, the water is shut off, pipes 52 and 53  
 being connected with the valve 45, as by  
 means of the strap 56, so as to swing there-  
 100 with. The flanges 48 and 50 when the valves  
 are in horizontal position dip into troughs  
 57, 58, the former of which is supported  
 upon an upright 60 and the latter upon the  
 arch 14. It will be understood of course  
 105 that shafts supporting the valves are hollow  
 only so far as will permit the water to flow  
 out through the exit orifices, the remainder  
 of the shaft being solid. Valves 45 and 46,  
 in the present instance are each made in two  
 110 parts and are mounted upon a hollow shaft,  
 the object of this construction being to per-  
 mit a more ready replacement when neces-  
 sary. This necessitates the dividing of the  
 passage ways 42 and 43 into smaller pas-  
 115 sage ways. By this arrangement repairs  
 will be facilitated and the valve will not be  
 so likely to become deformed or cracked.  
 Similar troughs 61 and 62 surround the pas-  
 sage way 43 and a central trough 63 extends  
 120 parallel with the arch 14, suitable openings  
 as at 64 being provided to allow the passage  
 of water to flow from the troughs 58 and 61  
 thereinto.

65 indicates openings adjacent the troughs  
 in the valve-chambers 30 and 31, through  
 125 which access may be had to the interior  
 when it is desired to clean out the troughs.  
 These openings may be closed by any de-  
 sired means.

Fixed upon the pivot of the valve 20 and

located exteriorly of the casing is a 180° segment 66, provided with teeth 67, which mesh with a gear-wheel 68, journaled upon a pivot 68' fast upon the casing. Fixed upon the pivot of the valve 45, is a 90° segment 69 provided exteriorly with teeth 70, which mesh with teeth formed upon a gear-wheel 71, mounted upon a pivot 72 fast upon the casing.

73 indicates a reciprocating rack formed with opposed teeth 74 and 75, one set of which meshes with the gear wheel 68, and the other with the teeth upon the gear-wheel 71 so that when the rack is moved in a longitudinal direction, the gears 68 and 71 will communicate the motion to the segments 66 and 69, and the rotation of the segments will rotate the valves 20 and 45. The pivotal valve 46 is provided exteriorly of the casing with a lever 76, which is connected by means of a link 77, with the segment 69, so that when that segment is rotated the said valve 46 will be moved in a direction corresponding to the movement of the valve 45. It will be noted that by means of the construction just described, at a given movement of the rack 73, the valve 20 will be moved from one closed position, over one of the passage ways 17 or 18, through an angle of 180° to close the opposite passage way, whereas the valves 45 and 46 will move through an angle of about 90°, or from open to closed positions or vice versa.

Rack 73 at its outer ends is provided with pistons 78 and 80 suitably packed as at 81, said pistons being adapted to traverse the cylinder 82. Leading into the opposite ends of the cylinder 82 are fluid pressure pipes 83 and 84 through which a fluid may be introduced to operate the pistons. It will be understood that pipes 83 and 84 may be connected with a suitable source of pressure supply, and that a fluid under pressure may be alternately introduced through said pipes to the opposite ends of the cylinder 82 whereby the rack 73 will be reciprocated, and the valves operated.

Having thus described the construction of this embodiment of my invention, the operation thereof may now be understood. With the parts in the position shown in the drawing gas will flow from the conduit 4 through the valve chamber 2, passage way 17, valve-chamber 30, passage way 38, and conduit 39 to the gas consuming apparatus, the products of combustion being discharged through the conduit 41, passage way 40, valve chamber 31, and passage way 43 to the stack 44. The ingoing gas is prevented from entering the stack by the valve 45 and the outgoing products of combustion are prevented from entering the valve chamber 2 by the valve 20. When the valves are moved to their opposite positions, the gas will flow from the conduit 4 to the gas consuming apparatus

through the valve chamber 2, passage way 18, valve chamber 31, passage way 40, and conduit 41, the products of combustion being discharged through the conduit 39, passage way 38, valve-chamber 30, passage way 42, to the stack flue 44.

The embodiment of my invention shown in Figs. 10 and 11 is quite similar to that just above described, but is adapted for use when a structure of less height is required. It will be noted that valve-chambers similar to those at 30 and 31 in the first described embodiment are provided at 85 and 86 at either side of the valve chamber 2, the gas being received through conduit 4 as in the embodiment first described. Passage ways 87 and 88 lead from valve chamber 2 directly into the conduits 90 and 91, which are connected with the gas consuming apparatus, and the conduits 92 and 93 extend rearwardly from the valve chambers 85 and 86 and connect with the stack flue 94, as shown in Fig. 11 of the drawings as indicated in dotted lines of Fig. 10. Passage ways 95 and 96 connect the conduits 90 and 91 respectively with the valve chambers 85 and 86. A double flanged valve 97 pivoted at 98 is adapted to close both of the passage ways 87 and 88, and the passage ways 95 and 96 are adapted to be closed by the valves 98 and 100. Valves 97, 98 and 100 may be connected to move in unison as in the first described embodiment, and water-cooling means is shown which forms a seal for the valve as in the embodiment first above described. The operation of this embodiment of my invention should be largely obvious from the above description and it will be understood that the gas from the source of supply with the parts in the position shown will flow from the conduit 4 to the valve chamber 2, passage way 88, and conduit 91, to the gas consuming apparatus and the products of combustion will be discharged through the conduit 90, passage way 95 and conduit 92 to the stack flue 94. When the valves are reversed the flow of gas and the products of combustion will be reversed throughout the apparatus.

It will accordingly be seen that I have provided apparatus particularly well adapted to attain, among others, all the ends and objects above pointed out in a simple yet efficient manner, and as many changes could be made in the above construction and many apparently widely different embodiments of this invention could be made without departing from the scope thereof, it is intended that all matter contained in the above description or shown in the accompanying drawings shall be interpreted as illustrative and not in a limiting sense. It is also to be understood that the language used in the following claims is intended to cover all of the generic and specific features of the

invention herein described and all statements of the scope of the invention, which as a matter of language, might be said to fall therebetween.

5 Having thus described my invention, what I claim as new and desire to secure by Letters Patent, is:

1. In apparatus of the class described, the combination in a valve structure, of a casing comprising a gas inlet conduit, a gas chamber into which said conduit leads, a pair of gas inlet ports leading from said gas chamber, a swinging valve pivotally mounted intermediate said ports and adapted alternately to open one of said ports and simultaneously close the other, said valve being provided upon either side with means for confining water thereon and when closing either of said ports resting in a horizontal position, means adapted alternately to discharge water upon the opposite sides of said valve, said discharging means being operative to discharge water upon the side which is uppermost, a pair of chambers for said inlet gas and exit fumes connected directly to said ports, a pair of normally open conduits, each of which is adapted to conduct gas to consuming apparatus and fumes therefrom, open passage ways leading from said last named chambers to said last named conduit, a stack flue, exit ports leading from said last named chambers to said stack flue, valves for said exit ports, and means for operating said valves.

2. In apparatus of the class described, the combination of a valve structure comprising a casing, the upper portion of which is provided with a gas chamber, a gas inlet conduit connected with said chamber, a pair of vertically disposed gas inlet ports leading from said gas chamber, a horizontally disposed valve adapted alternately to open and close said ports, a pair of chambers disposed beneath said gas chamber, each of which is connected therewith by one of said ports, a pair of normally open conduits, each of which is adapted to conduct gas to consuming apparatus and to conduct fumes therefrom, normally open (passage ways connecting said last named chambers with said last named conduits, a stack flue, passage ways connecting said stack flue with said last named chambers, a pair of swinging valves, one for each of said last named passage ways, each valve being adapted when lying in a horizontal position to close its passage way and when swung to a vertical position to open its passage way, and means for simultaneously operating said valves.

3. In apparatus of the class described, in combination, a casing having a valve chamber, a pair of valve chambers located adjacent said first valve chamber, a pair of passage ways connecting said first valve cham-

ber with the other valve chambers, troughs adapted to contain water located contiguous to said passage ways, a pivotally mounted valve adapted alternately to open and close said passage ways, and an inlet valve located in the pivotal portion of said swinging valve adapted alternately to discharge water upon the opposite sides of said swinging valve.

4. In apparatus of the kind described, in combination, a casing provided at its upper portion with a valve chamber, a pair of valve chambers arranged immediately below said valve chamber and connected therewith by means of passage ways, troughs for containing water disposed contiguous to said passage ways, a pivotally mounted valve adapted to be swung to position to close either of said passage ways while simultaneously opening the other, oppositely disposed flanges provided upon said valve whereby when the valve is swung in one direction to cover said passage way the flanges dip into the troughs surrounding that passage way to form a water seal, and means for conducting water through the pivotal portion of said valve and discharging the same on the portion of the valve which is uppermost.

5. In apparatus of the class described, in combination, a valve structure comprising a casing divided into a plurality of compartments connected by passage ways, a pivotally mounted valve adapted alternately to open and close certain of said passage ways, a channel for containing water formed contiguous to said passage ways, means for discharging water through the pivotal portion of said valve upon the same, and means whereby the water may flow from the valve into said channels.

6. In apparatus of the class described, in combination, a casing provided with a valve chamber, a gas conduit leading thereinto, a plurality of valve chambers located adjacent said first mentioned valve chamber and connected therewith by means of passage ways, a swinging valve adapted alternately to open and close said passage ways, a stack flue, passage ways connecting said second mentioned valve chamber with said stack flue, a pair of valves for alternately opening and closing the passage ways connecting said passage ways with the stack flue, a cylinder, a pair of pistons connected with a rack located in said cylinder, segments connected with said valves, and gears connecting said rack with said segments whereby when the rack is moved said gears will be simultaneously operated.

7. In apparatus of the class described, in combination, a casing having compartments connected by means of passage ways, a trough provided about each of said passage ways, a pivotally mounted valve for open-

ing and closing said passage ways, said valve being provided with opposed flanges whereby when said valve is moved in one direction the flanges will dip into the water seal and  
 5 opposed flanges thereof will form a receptacle for water, and a pipe provided upon said valve adapted when the same is moved in one position to discharge water upon the side of the valve which is uppermost, and  
 10 when the valve is moved to another position so that another side is uppermost, to discharge water upon that side.

8. In apparatus of the class described, in combination, a casing provided with a plurality of compartments connected by passage ways, swinging valves for opening and closing said passage ways, comprising one valve adapted to be moved through an arc of 180° from one closed position to another,  
 20 said valve when in a closed position being disposed horizontally, said valve having means upon either side thereof for confining water thereon, means for discharging water upon whichever side of said valve is  
 25 uppermost, a pair of valves, each of which is adapted to be swung through an arc of 90° from a closed position to an open position or from an open position to a closed position, one side of each of said valves having  
 30 means for confining water thereon, means for discharging water upon each of said valves when the same is in a closed position, and a common means for operating all of said valves.

9. In apparatus of the class described, in combination, a casing provided with compartments connected with passageways, a plurality of swinging valves for said passageways, and a single shaft for supporting said valves. 35 40

10. In apparatus of the class described, in combination, a casing provided with compartments connected by means of passage ways, swinging valves for opening and closing said passage ways, a hollow shaft for supporting one of said valves provided with means for discharging water upon either side of said valve, the arrangement being such that the water is discharged upon the side of the valve which is uppermost, hollow shafts for supporting the others of said valves provided with means for discharging water upon one side of said valves. 45 50

11. In apparatus of the class described, in combination, a casing provided with compartments connected with passageways, swinging valves for opening and closing said passage ways, a single hollow shaft for supporting said valves, and means for discharging water into said shaft whereby the same may flow upon said valve. 55 60

In testimony whereof I affix my signature in the presence of two witnesses.

JAMES A. HERRICK.

Witnesses:

A. S. HONIGSBERG,  
 CHARLES S. FOLTZ.