



(22) Date de dépôt/Filing Date: 2005/04/28

(41) Mise à la disp. pub./Open to Public Insp.: 2006/01/01

(45) Date de délivrance/Issue Date: 2013/11/26

(30) Priorité/Priority: 2004/07/01 (US10/883,081)

(51) Cl.Int./Int.Cl. *H01J 61/02* (2006.01)

(72) Inventeurs/Inventors:
KLINEDINST, KEITH A., US;
SHINN, DENNIS B., US

(73) Propriétaire/Owner:
OSRAM SYLVANIA INC., US

(74) Agent: SMART & BIGGAR

(54) Titre : METHODE POUR CONTROLER LA PERTE DE MERCURE PAR DES LAMPES

(54) Title: METHOD OF CONTROLLING LEACHABLE MERCURY IN LAMPS

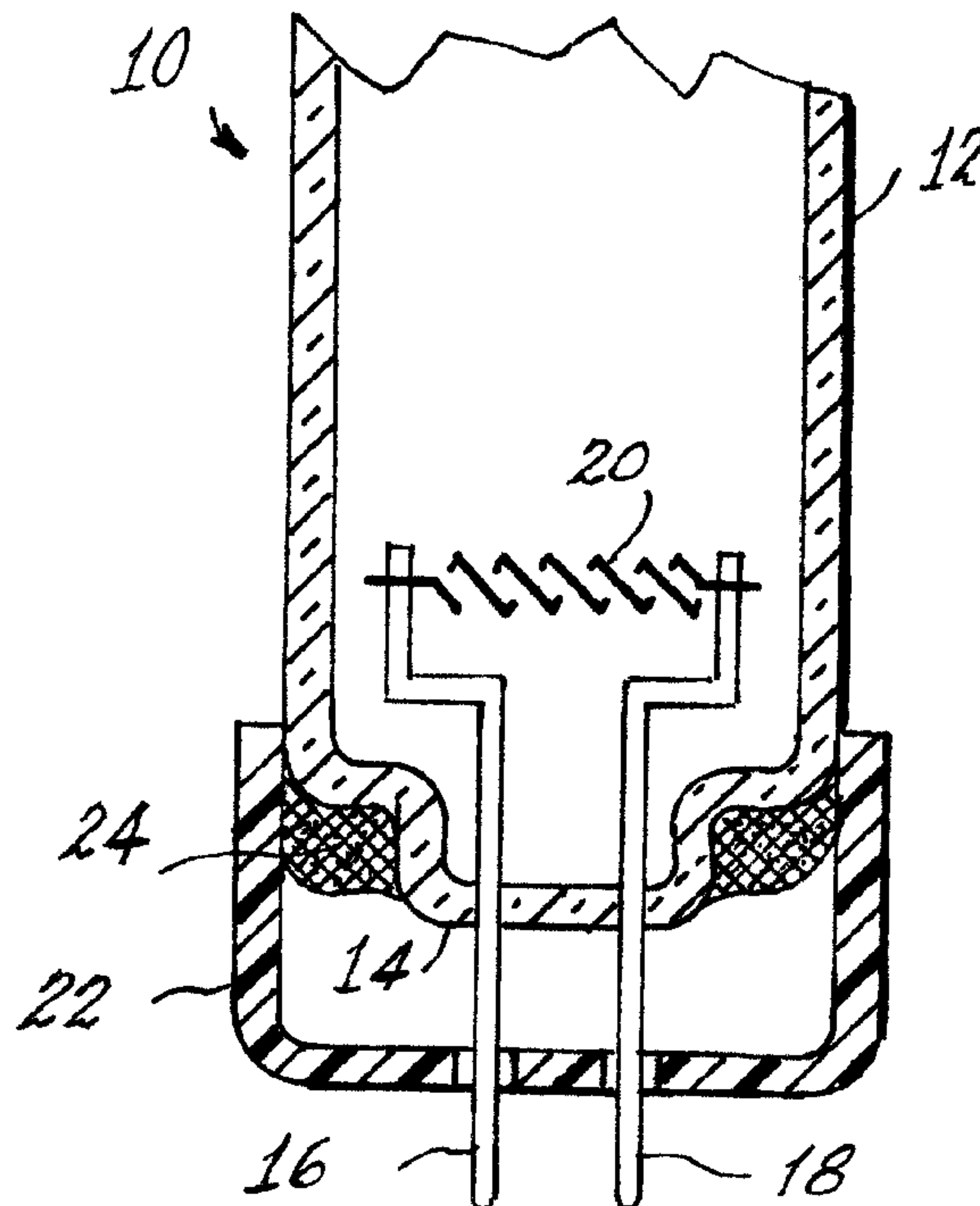

(57) Abrégé/Abstract:

A method for inhibiting mercury from leaching from a land-filled arc discharge lamp containing a quantity of elemental mercury at least partially convertible to soluble mercury, provides for including within the lamp a quantity of a non-metallic copper-containing compound and an ingredient X, said ingredient X including a noble metal or a noble metal compound selected from the group consisting of silver and compounds of silver, gold and platinum, and a lamp containing same. The inhibiting compound is preferably included with the basing cement.



ABSTRACT

A method for inhibiting mercury from leaching from a land-filled arc discharge lamp containing a quantity of elemental mercury at least partially convertible to soluble mercury, provides for including within the lamp a quantity of a non-metallic copper-containing compound and an ingredient X, said ingredient X including a noble metal or a noble metal compound selected from the group consisting of silver and compounds of silver, gold and platinum, and a lamp containing same. The inhibiting compound is preferably included with the basing cement.

METHOD OF CONTROLLING LEACHABLE MERCURY IN LAMPS**001 TECHNICAL FIELD**

002 This invention relates to mercury vapor discharge lamps and more particularly to fluorescent lamps. Still more particularly it relates to lamps that can be landfilled without leaching potentially damaging mercury into the environment.

003 BACKGROUND ART

004 During the manufacture of a fluorescent lamp, as well as other types of arc discharge lamps, a quantity of elemental mercury is sealed within the lamp envelope. It is known that in operation some of the elemental mercury contained in these lamps can be converted to a mercuric oxide or a mercury salt. This is true in fluorescent lamps in particular. In such lamps most of this mercury adheres to the phosphor coating deposited upon the inside wall of the lamp envelope, leaving only a small portion of the mercury in the form of mercury vapor. After the alkaline earth metal oxides coating the lamp electrodes are volatilized, the oxides decompose in the discharge space, and the freed oxygen converts some of this elemental mercury to a salt or compound such as the above-mentioned mercuric oxide (HgO) which is water soluble.

005 There is a growing concern that a waste stream resulting from the disposal of arc discharge lamps such as fluorescent lamps may leach excessive amounts of soluble mercury into the environment. One method of measuring the amount of soluble mercury, which may leach from the waste stream resulting from the disposal of fluorescent lamps, is described in the Toxicity Characteristic Leaching Procedure (TCLP) prescribed on pages 26987-26998 of volume 55, number 126 of the June 29, 1990 issue of the Federal Register. According to the procedure, the lamp being tested is pulverized into granules having a surface area per gram of material equal to or greater than 3.1 cm² or having a particle size smaller than 1 cm in its narrowest dimension. Following pulverization, the granules are subjected to a sodium acetate

buffer solution having a pH of approximately 4.93 and having a weight twenty times the weight of the granules.

006 At the present time, the Environmental Protection Agency defines a maximum concentration level for mercury at 0.2 milligram leachable mercury per liter extract fluid when the TCLP is applied. According to present standards, a fluorescent lamp is considered nonleachable, and thus available for conventional landfill deposition, when less than 0.2 milligram per liter of leachable mercury results from a TCLP extraction.

007 Various methods have been proposed which attempt to treat or process burned-out discharge lamps or scrap lamp exhaust tubing containing mercury in order to reclaim the mercury and thereby reduce the amount of mercury-contaminated scrap. These methods are summarized as background in U.S. 5,229,686 and U.S. 5,229,687, which describe methods by which to render a mercury vapor lamp nonleaching upon disposal without the use of expensive treatment processes to reclaim the mercury. The method of U.S. 5,229,686 employs a chemical agent, enclosed within the lamp, suitable for chemically combining a substantial portion of the soluble mercury as a sparingly soluble salt when the lamp is pulverized as a result of disposal. The method of U.S. 5,229,687 employs a chemical agent, enclosed within the lamp, suitable for electrochemically reducing a substantial portion of the soluble mercury to elemental mercury, again when the lamp is pulverized during disposal. Preferably, this chemical agent is an element which has an electrode potential for oxidation reactions higher than mercury but which is not sufficiently active to displace hydrogen from acidic aqueous solutions. In a preferred embodiment, the chemical agent is sealed within an enclosure (e.g., glass), which is rupturable upon pulverization of the lamp. In another embodiment, the chemical agent is mixed with the basing cement used to secure the lamp bases to the glass envelope. The chemical agent acts to reduce soluble mercury produced during lamp operation to elemental mercury, which is not leachable as measured by the TCLP.

008 The chemical agent used in '687 may be used in various forms, e.g., as a powder, dust, wire mesh, or metallic foil. The amount or size of the chemical agent is directly related to the surface area and surface condition, finely divided metallic powders being preferred over a solid mass because of their relatively large effective surface areas. Because of their availability and inexpensive cost, iron and copper, in the form of a powder or dust, are preferred. The amount of chemical agent present should be sufficient to electrochemically reduce the amount of soluble mercury within the lamp which is leached at the time of disposal to less than 0.2 milligram per liter of an aqueous acid solution such as a sodium acetate buffer solution as prescribed in the TCLP.

009 However, there are several disadvantages to the methods described in U.S. 5,229,686 and '687. In regard to '686, the quantity of chemical agent required to chemically combine nearly all of the mercury within a fluorescent lamp may be so large as to be inconvenient or impossible to contain within a standard lamp envelope. In regard to '687, the metallic copper or iron reduces the amount of leachable mercury via a surface redox reaction between adsorbed mercury ions and zero-valent metal atoms. In order for this reaction to occur, the dissolved ionic mercury must first find its way to and become adsorbed upon the metal surface. Thus, the effectiveness of a metallic element as a means of reducing leachable mercury will ultimately be limited by the rates at which mercury ions diffuse to the metal surface and become adsorbed thereon. A means of reducing leachable mercury that did not depend upon the chance contact between dissolved mercury ions and a metal surface followed by the adsorption of the mercury upon that surface would be likely to be more efficient and, therefore, preferable.

010 It may also be difficult or impossible to incorporate a sufficiently large quantity of a finely divided metal within a fluorescent lamp, the more so the smaller or more compact the lamp. In a small lamp, the only convenient way to introduce the metal may be as a component of the basing cement. However, the electrical conductivity of the metal may prevent its incorporation into the basing cement since the cement may easily come into

contact with internal electrical leads. On the other hand, electrically insulating materials might easily be added to the basing cement in addition to or in place of the normal CaCO_3 cement filler without risk of creating electrical short circuits within the lamp.

011 In U.S. 5,736,813, it is disclosed that "the formation of leachable mercury upon disposal or during TCLP testing of mercury vapor discharge lamps is substantially prevented by incorporation of a pH control agent in the lamp structure or in the test solution to provide a pH of about 5.5 to 6.5." A low pressure mercury discharge lamp is claimed which includes about 5-15 grams of a pH control agent (generally a water-soluble base) which, it is suggested, is sufficient to substantially prevent formation of ferric and cupric compounds which oxidize elemental mercury to a soluble form. The primary disadvantage of this method of reducing mercury leaching is that it may be difficult or, depending upon the lamp type, practically impossible to package the relatively large amounts of the required pH control agent (5-15 grams) within the structure of a typical mercury vapor lamp.

012 Recently, an improved mercury vapor discharge lamp was described in which an effective amount of a nonmetallic copper-containing compound which, when the lamp is pulverized to granules and subjected to a suitable aqueous acid solution, dissolves in the acid solution, resulting in a concentration of extracted mercury less than 0.2 mg per liter of solution. The effective amount of soluble copper is relatively small (between 0.1 and 4 mg per gram of total lamp weight, depending upon lamp type and size, total mercury loading, etc.). However, copper in the environment, although relatively harmless, may be toxic to certain marine invertebrates. In order to eliminate the possibility of damage to ecological systems, the EPA has placed a limit of 25 mg/L for copper levels in discharges from nonferrous operations to lakes and streams. It is desirable, therefore, to minimize the amount of soluble copper, which is effective with respect to the control of mercury leaching. Further, the smaller the quantity of nonmetallic copper-containing compound, the more easily it will be to incorporate within the lamp.

013 The use of so-called noble metals and metal salts has also been suggested for the control of mercury leaching in fluorescent lamps. U.S. Patent No. 6,515,421 describes a method and apparatus for preventing the formation of leachable mercury in mercury arc vapor discharge lamps, which comprises coating at least one of the metallic components of the lamp with at least one noble metal coating (typically silver or palladium). A method and apparatus for preventing the formation of leachable mercury in mercury arc vapor discharge lamps which comprises providing in the lamp structure an effective amount of a silver salt, gold salt, or combination thereof, is described in U.S. Published Patent Application No. 2002/0190646 A1. While these methods may be effective for the control of leachable mercury, they are generally not practical due to the relatively high costs of the noble metals and metal salts. However, the use of such noble metals or metal salts might become practical if a relatively inexpensive means were found to substantially reduce the amounts of these substances which are required to effectively reduce or control mercury leaching.

014 SUMMARY

015

016 It is desirable to enhance the disposability of mercury-containing discharge lamps.

017 It is also desirable to provide a method for controlling leachable mercury in discharge lamps.

018 According to one aspect of the invention there is provided a method for inhibiting mercury from leaching from a land-filled arc discharge lamp that contains a quantity of elemental mercury at least partially convertible to soluble mercury, the method comprising including within the lamp a quantity of a non-metallic copper-containing compound and an ingredient X, said ingredient X including a noble metal or noble metal compound selected from the group consisting of silver and compounds of silver, platinum and gold.

019 The combination of the non-metallic copper-containing compound and the noble metal or noble metal compound provides a method that may be effective, inexpensive and easy to apply.

019a According to another aspect of the invention there is provided a method for inhibiting mercury from leaching from a land-filled arc discharge lamp containing a quantity of elemental mercury at least partially convertible to soluble mercury, the method comprising: including within the lamp a quantity of a non-metallic copper-containing compound and platinum chloride as PtCl_2 .

020 BRIEF DESCRIPTION OF THE DRAWINGS

021 Fig. 1 is a graph providing test results with various amounts of silver addition;

022 Fig. 2 is a graph providing test results with various amounts of ionic copper addition;

023 Fig. 3 is a diagrammatic view of a lamp employing an embodiment of the invention; and

024 Fig. 4 is a view similar to Fig. 3 of an alternate embodiment.

025 BEST MODE FOR CARRYING OUT THE INVENTION

026 For a better understanding of the present invention, together with other and further objects, advantages and capabilities thereof, reference is made to the following disclosure and appended claims taken in conjunction with the above-described drawings.

027 Referring now to the invention with greater particularity, it has been discovered that a relatively small amount of a soluble non-metallic copper-containing compound used in combination with a small quantity of metallic silver or a compound of silver, platinum,

Page 6a

or gold in the Toxicity Characteristic Leaching Procedure applied to a mercury vapor discharge lamp containing a quantity of mercury that is at least partially convertible to soluble mercury may be much more effective in preventing mercury leaching than either the copper-containing

compound or the metallic silver or compound of silver, platinum, or gold used alone. Thus, as a result of the presence of a small amount of metallic silver or a compound of silver, platinum, or gold, concentrations of extracted mercury much less than 0.2 mg per liter of solution may be obtained with quantities of soluble copper-containing compounds substantially smaller than would be required to achieve the same extracted mercury concentrations in the absence of the metallic silver or compound of silver, platinum, or gold. Conversely, as a result of the presence of a relatively small amount of a soluble copper-containing compound, concentrations of extracted mercury much less than 0.2 mg per liter of solution may be obtained with quantities of metallic silver or of compounds of silver, platinum, or gold substantially smaller than would be required to achieve the same extracted mercury concentrations in the absence of the dissolved copper compound. Various aspects of this invention are presented in the following examples.

028 Example 1

029 A series of four TCLP tests were carried out with commercial 32WT8 fluorescent lamps manufactured without metallic mercury but with 6 mg of ionic mercury (as HgO) soluble in the TCLP extraction fluid. No additives were used in one of the tests. However, each of the other three tests included 50 mg of copper as the compound copper dihydroxide carbonate (CDC), 4 mg (4×10^{-5} mole) of finely divided metallic silver (with most particles in the 0.5 – 1.0 micron range), or a combination of the two. The TCLP test results (leached mercury concentration in units of mg per liter of extraction fluid) are listed in Table I below for T8 lamps with 6 mg soluble Hg²⁺.

030 TCLP Results for T8 Lamps without Metallic Hg, with 6 mg Soluble Hg²⁺, and with a Soluble Copper-Containing Compound (CDC), Finely Divided (0.5 – 1.0 Micron) Metallic Silver, a Combination of CDC and Finely Divided Metallic Silver, or No Additive Added at the Start of the Test

Cu (as CDC) (mg)	Ag (0.5-1.0 micron) (mg)	Leached Hg (mg/L)
0	0	0.82
50	0	0.31
0	4	0.29
50	4	0.05

Table I

031 It is seen that a relatively small amount of a soluble nonmetallic copper-containing compound used in combination with a small quantity of metallic silver in the Toxicity Characteristic Leaching Procedure applied to a mercury vapor discharge lamp containing a quantity of mercury that is soluble in the acidic extraction fluid may be much more effective in preventing mercury leaching than either the copper-containing compound or the metallic silver used alone.

032 Example 2

033 Additional TCLP tests were carried out in the same way as those described in Ex. 1 except that 4 mg of silver as silver oxide, Ag_2O , was used rather than metallic silver. As before, tests were performed both with and without the presence of 50 mg of copper as CDC. The results of these tests, along with those performed without the addition of silver oxide, are compared in Table 2 below.

034 TCLP Results for T8 Lamps without metallic mercury, with 6 mg Soluble Hg^{2+} and with a Soluble Copper-Containing Compound (CDC), Silver Oxide (Ag_2O), a Combination of CDC and Silver Oxide, or No Additive Added at the Start of the Test.

Cu (as CDC) (mg)	Ag (as Ag ₂ O) (mg)	Leached Hg (mg/L)
0	0	0.82
50	0	0.31
0	4	0.24
50	4	0.07

Table II

035 It is seen that a relatively small amount of a soluble nonmetallic copper-containing compound used in combination with a small quantity of silver oxide in the Toxicity Characteristic Leaching Procedure applied to a mercury vapor discharge lamp may be much more effective in preventing mercury leaching than either the copper-containing compound or the silver compound used alone.

036 Example 3

037 Additional TCLP tests were carried out in the same way as those described in Ex. 2 except that 4 mg of silver as silver carbonate, Ag₂CO₃, was used rather than silver oxide. As before, tests were performed both with and without the presence of 50 mg of copper as CDC. The results of these tests, along with those performed without the addition of silver carbonate, are compared in Table 3 below.

038 TCLP Results for T8 Lamps without Metallic Hg, with 6 mg Soluble Hg²⁺ and with a Soluble Copper-Containing Compound (CDC), Silver Carbonate (Ag₂CO₃), a Combination of CDC and Silver Carbonate, or No Additive Added at the Start of the Test.

Cu (as CDC) (mg)	Ag (as Ag ₂ CO ₃) (mg)	Leached Hg (mg/L)
0	0	0.82
50	0	0.31
0	4	0.24
50	4	0.12

Table III

039 As in the preceding example, it is seen that a relatively small amount of a soluble nonmetallic copper-containing compound used in combination with a small quantity of a silver compound in the Toxicity Characteristic Leaching Procedure applied to a mercury vapor discharge lamp may be much more effective in preventing mercury leaching than either the copper-containing compound or the silver compound used alone.

040 Example 4

041 Additional TCLP tests were carried out in the same way as those described in the preceding examples except that 4 mg of silver as silver chloride, AgCl, was used rather than metallic silver or another silver compound. As before, tests were performed both with and without the presence of 50 mg of copper as CDC. The results of these tests, along with those performed without the addition of silver chloride, are compared in Table 4 below.

042 TCLP Results for T8 Lamps without Metallic Hg, with 6 mg Soluble Hg²⁺ and with a Soluble Copper-Containing Compound (CDC), Silver Chloride (AgCl), a Combination of CDC and Silver Chloride, or No Additive Added at the Start of the Test

Cu (as CDC) (mg)	Ag (as AgCl) (mg)	Leached Hg (mg/L)
0	0	0.82
50	0	0.31
0	4	0.21
50	4	0.05

Table IV

043 As in the preceding examples, it is seen that a relatively small amount of a soluble nonmetallic copper-containing compound used in combination with a small quantity of a silver compound in the Toxicity Characteristic Leaching Procedure applied to a mercury vapor discharge lamp may be much more effective in preventing mercury leaching than either the copper-containing compound or the silver compound used alone.

044 Example 5

045 Additional TCLP tests were carried out in the same way as those described in the preceding example except that 7 mg (4×10^{-5} mole) of gold as gold chloride, AuCl_3 , was used rather than silver chloride. As before, tests were performed both with and without the presence of 50 mg of copper as CDC. The results of these tests, along with those performed without the addition of gold chloride, are compared in Table 5 below.

046 TCLP Results for T8 Lamps without Metallic Hg, with 6 mg Soluble Hg^{2+} , and with a Soluble Copper-Containing Compound (CDC), Gold Chloride (AuCl_3), a Combination of CDC and Gold Chloride, or No Additive Added at the Start of the Test.

Cu (as CDC) (mg)	Au (as AuCl ₃) (mg)	Leached Hg (mg/L)
0	0	0.82
50	0	0.31
0	7	0.51
50	7	0.10

Table V

047 As in the preceding examples, it is seen that a relatively small amount of a soluble nonmetallic copper-containing compound used in combination with a small quantity of a gold compound in the Toxicity Characteristic Leaching Procedure applied to a mercury vapor discharge lamp may be much more effective in preventing mercury leaching than either the copper-containing compound or the gold compound used alone.

048 Example 6

049 Additional TCLP tests were carried out in the same way as those described in the preceding example except that 8 mg (4×10^{-5} mole) of platinum as platinum chloride, PtCl₂, was used rather than silver chloride. As before, tests were performed both with and without the presence of 50 mg of copper as CDC. The results of these tests, along with those performed without the addition of gold chloride, are compared in Table 6 below.

050 TCLP Results for T8 Lamps without Metallic Hg, with 6 mg Soluble Hg²⁺ and with a Soluble Copper-Containing Compound (CDC), Platinum Chloride (PtCl₂), a Combination of CDC and Platinum Chloride, or No Additive Added at the Start of the Test.

Cu (as CDC) (mg)	Pt (as PtCl ₂) (mg)	Leached Hg (mg/L)
0	0	0.82
50	0	0.31
0	8	0.52
50	8	0.03

Table VI

051 As in the preceding examples, it is seen that a relatively small amount of a soluble nonmetallic copper-containing compound used in combination with a small quantity of a platinum compound in the Toxicity Characteristic Leaching Procedure applied to a mercury vapor discharge lamp may be much more effective in preventing mercury leaching than either the copper-containing compound or the platinum compound used alone.

052 Example 7

053 Additional TCLP tests were carried out in the same way as were those described in Ex. 1. However, in this case, two series of tests were conducted with increasing amounts of finely divided metallic silver (with most particles in the 0.5 – 1.0 micron range). 50 mg of copper as the compound copper dihydroxide carbonate (CDC) was included in one series of tests, while the other series of tests were carried out without the addition of a soluble copper-containing compound. The results of these TCLP tests (extracted mercury concentrations obtained with and without the addition of CDC) are plotted in Fig. 1 vs. the amount of metallic silver that was included in each test. As indicated, the amount of metallic silver needed to reduce the leachable mercury concentration to below the 0.2 mg/l threshold level in the presence of only 50 mg of soluble copper is a small fraction of that required in the absence of the soluble copper compound.

054 Example 8

055 Three additional series of TCLP tests were carried out similar to those described in Ex. 7. However, in each of these test series, the amount of soluble copper (as CDC) was systematically varied while the amount of metallic silver powder was held constant at 0, 3, or 5 mg. The results of these TCLP tests (extracted mercury concentrations obtained with the addition of 0, 3, or 5 mg of 0.5 – 1.0 micron metallic silver powder) are plotted in Fig. 2 vs. the amount of soluble copper that was included in each test. As shown, the amount of soluble copper needed to reduce the leachable mercury concentration to below the 0.2 mg/l threshold level decreases rapidly with the addition of very small amounts of metallic silver.

056 Example 9

057 Additional TCLP tests were carried out with commercial 32WT8 fluorescent lamps manufactured without metallic mercury but with 8.5 mg of ionic mercury (as HgO) soluble in the TCLP extraction fluid. Several tests were run with lamps having each of three different basing cement compositions. The basing cement was a typical cement comprising an inert filler of CaCO₃ and a polymer such as phenol formaldehyde. Type 1 cement was formulated in the normal way except that it contained about 34 mg of silver as Ag₂CO₃. Type 2 cement was formulated in the normal way except that it contained about 250 mg of copper (as CDC, substituted for about 25% of the CaCO₃ cement filler material). Type 3 cement was identical to type 2, except that it contained about 17 mg of silver (as Ag₂CO₃) in addition to about 250 mg of copper (as CDC). The averaged TCLP results obtained with lamps containing each of these three cement compositions are listed in Table 7 below.

058 Fig. 3 illustrates diagrammatically a portion of a fluorescent lamp 10 having an envelope 12 sealed at one end 14. Two electrical lead-ins 16, 18 are sealed into the end 14 and interior of the envelope mount a filamentary cathode 20. Exteriorly of the envelope the lead-ins project from a base 22 for connection to a power source. The base 22 is cup-shaped and sealed to the envelope 12 by a basing cement 24, which can be formulated as described above.

059 TCLP Results for T8 Lamps without Metallic Hg, with 8.5 mg Hg²⁺ (as HgO), and with Type 1, 2, or 3 Basing Cement.

Cement Type	Ag (as Ag ₂ CO ₃) (mg)	Cu (as CDC) (mg)	Leached Hg (mg/L)
1	34	0	0.21
2	0	250	0.20
3	17	250	0.02

Table VII

060 It is seen that leachable mercury concentrations at or above the regulatory threshold are obtained with lamps manufactured with cements containing about 34 mg of silver or about 250 mg of copper (as compounds soluble in the TCLP extraction fluid). However, almost no mercury is leached from a lamp manufactured with a cement containing only 17 mg of silver (as Ag₂CO₃) combined with only 250 mg of soluble copper (as CDC).

061 Alternatively, a quantity 25 of the non-metallic copper-containing compound and the noble metal or noble metal compound can be applied as a coating on the inside surface 26 of the base 22, as is shown in Fig. 4.

062 While there have been shown and described what are presently considered to be the preferred embodiments of the invention, it will be apparent to those skilled in the art that various changes and modifications can be made herein.

CLAIMS:

What is claimed is:

1. A method for inhibiting mercury from leaching from a land-filled arc discharge lamp containing a quantity of elemental mercury at least partially convertible to soluble mercury, said method comprising:

including within said lamp a quantity of a non-metallic copper-containing compound and an ingredient X, said ingredient X including a noble metal or noble metal compound selected from the group consisting of silver and compounds of silver, gold and platinum.

2. The method of claim 1 wherein said soluble mercury is present as mercury oxide.

3. The method of claim 1 or 2 wherein said non-metallic copper-containing compound comprises copper dihydroxide carbonate.

4. The method of any one of claims 1 to 3 wherein said ingredient X comprises elemental silver.

5. The method of any one of claims 1 to 3 wherein said ingredient X comprises silver oxide as Ag_2O .

6. The method of any one of claims 1 to 3 wherein said ingredient X comprises silver carbonate.

7. The method of any one of claims 1 to 3 wherein said ingredient X comprises gold chloride as AuCl_3 .

8. The method of any one of claims 1 to 7 wherein said arc discharge lamp has a base held to said lamp by a basing cement and said non-metallic copper-containing compound and ingredient X are included in said basing cement.

9. A method for inhibiting mercury from leaching from a land-filled arc discharge lamp containing a quantity of elemental mercury at least partially convertible to soluble mercury, said method comprising:
including within said lamp a quantity of a non-metallic copper-containing compound and platinum chloride as PtCl₂.

10. The method of claim 9 wherein said soluble mercury is present as mercury oxide.

11. The method of claim 9 or 10 wherein said non-metallic copper-containing compound comprises copper dihydroxide carbonate.

12. The method of any one of claims 9 to 11 wherein said arc discharge lamp has a base held to said lamp by a basing cement and said non-metallic copper-containing compound and platinum chloride are included in said basing cement.

04-1-746
1/2

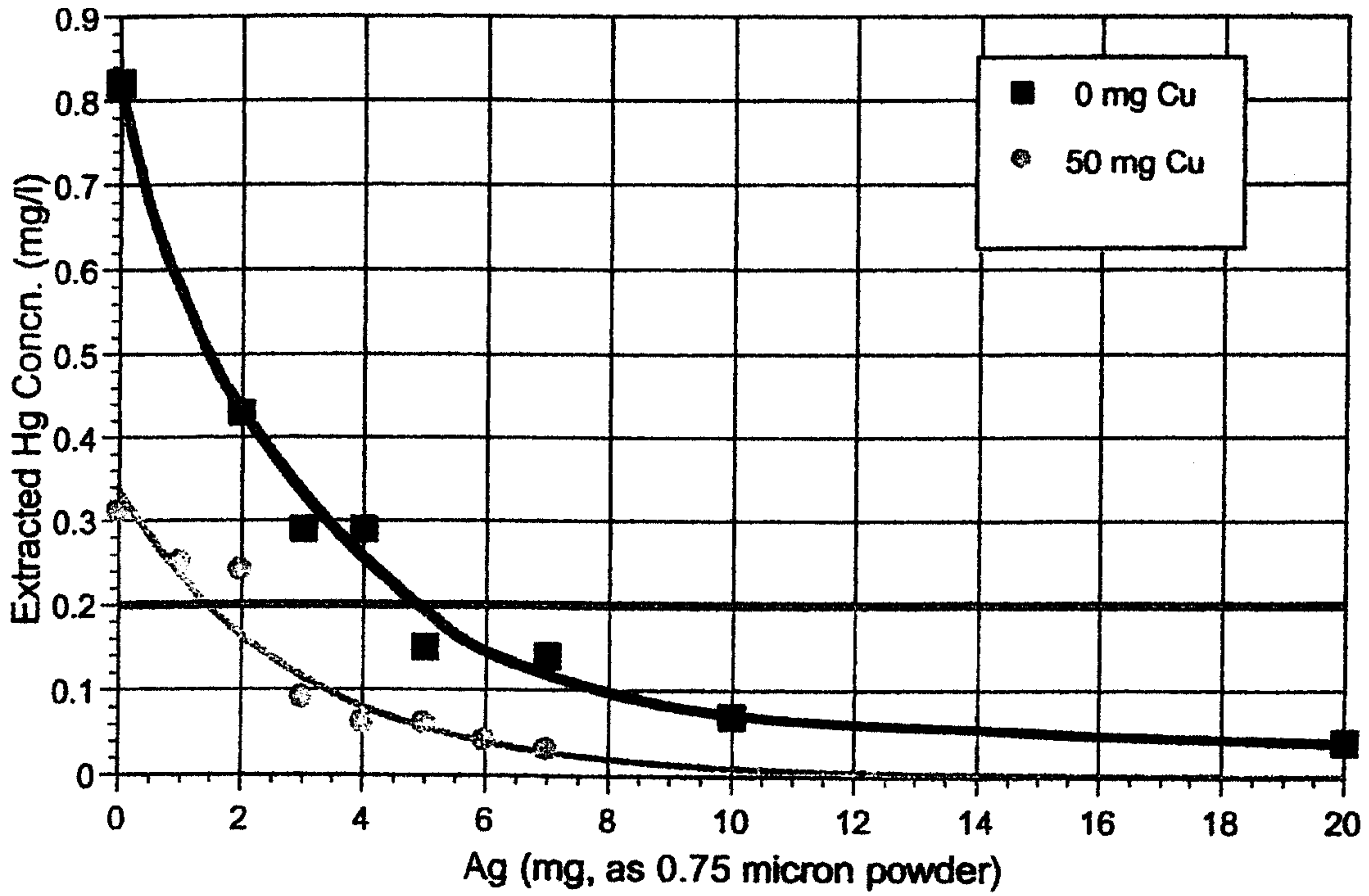

Fig. 1

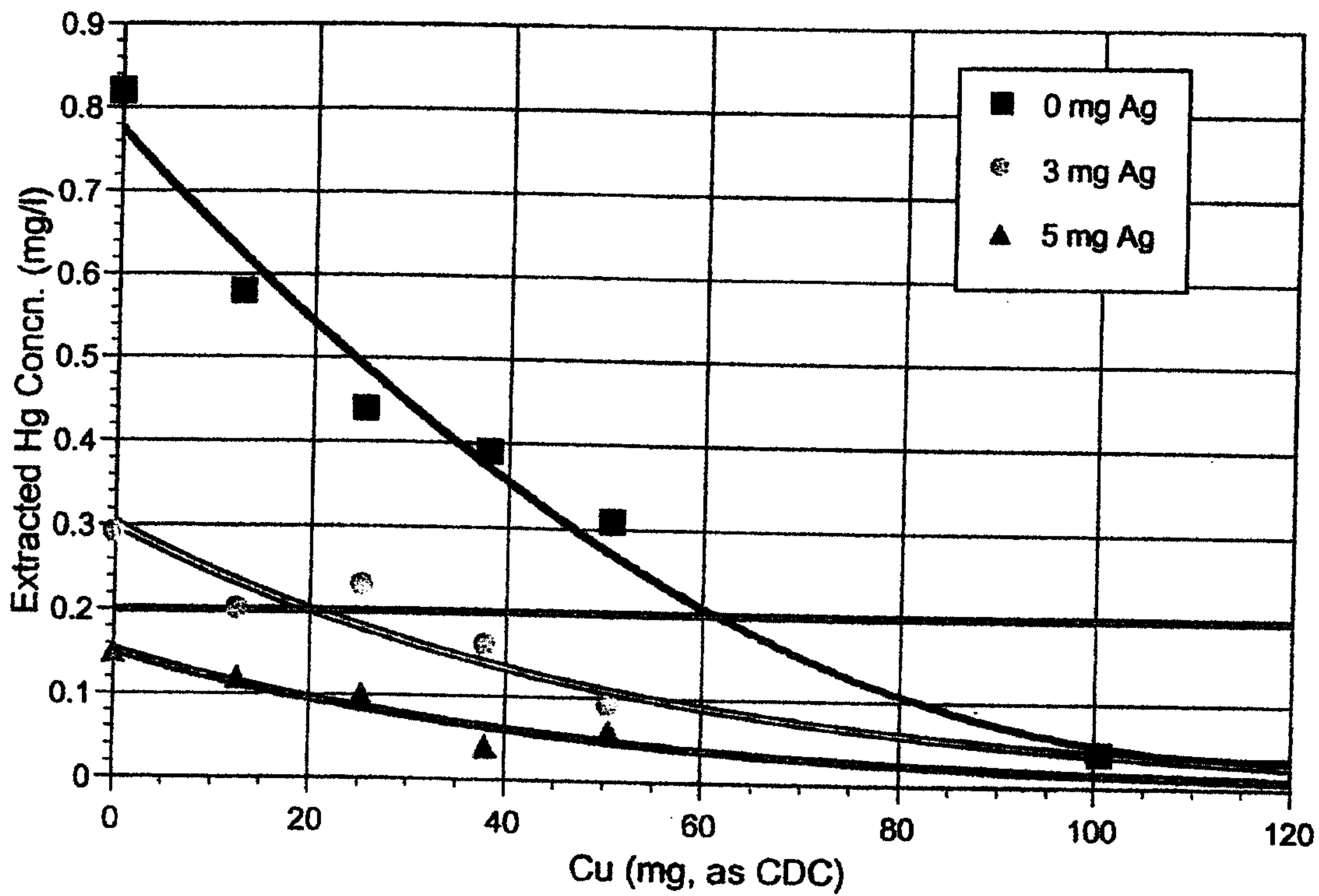

Fig. 2

Patent Agents
Fetherstonhaugh & Co.

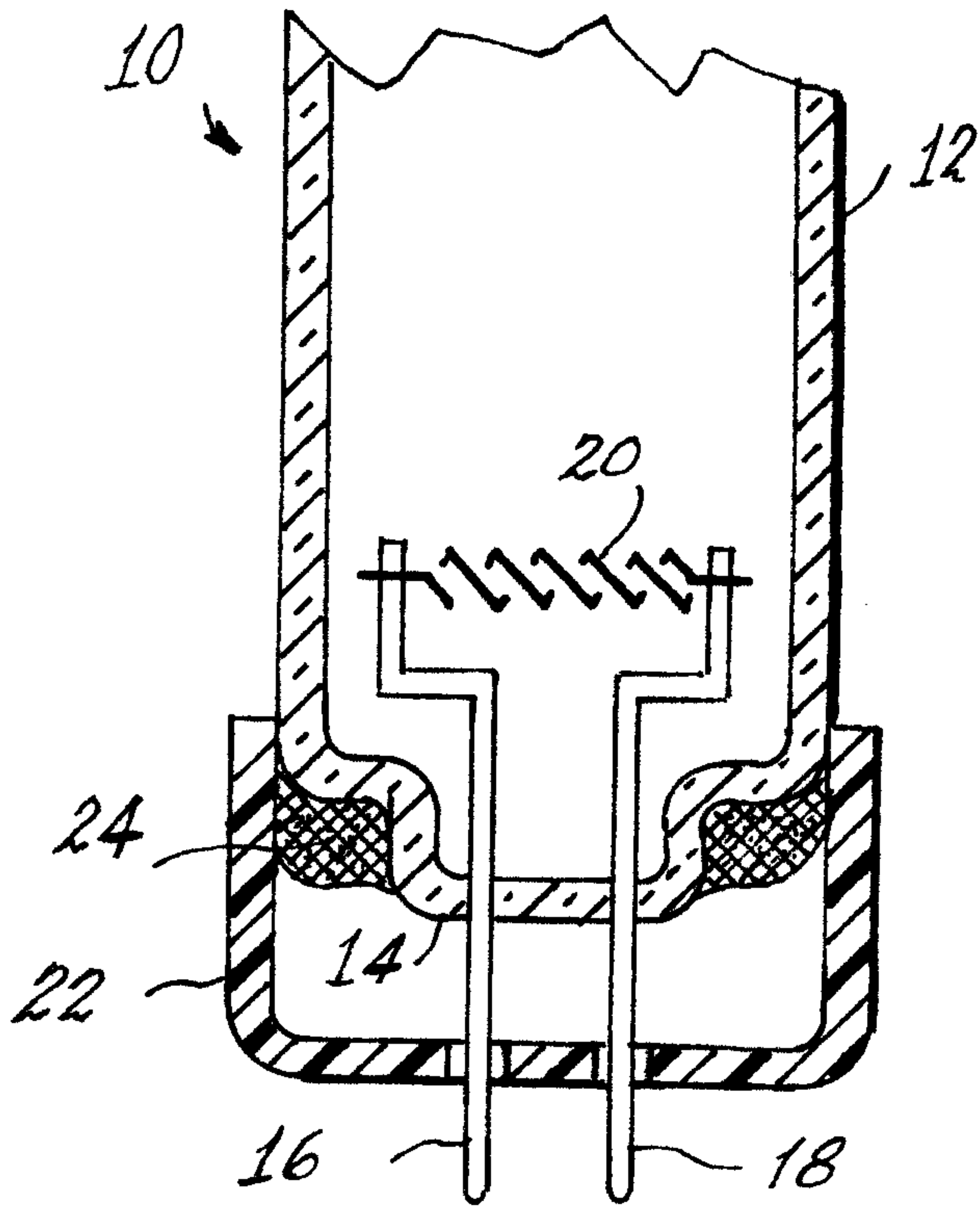

Fig. 3

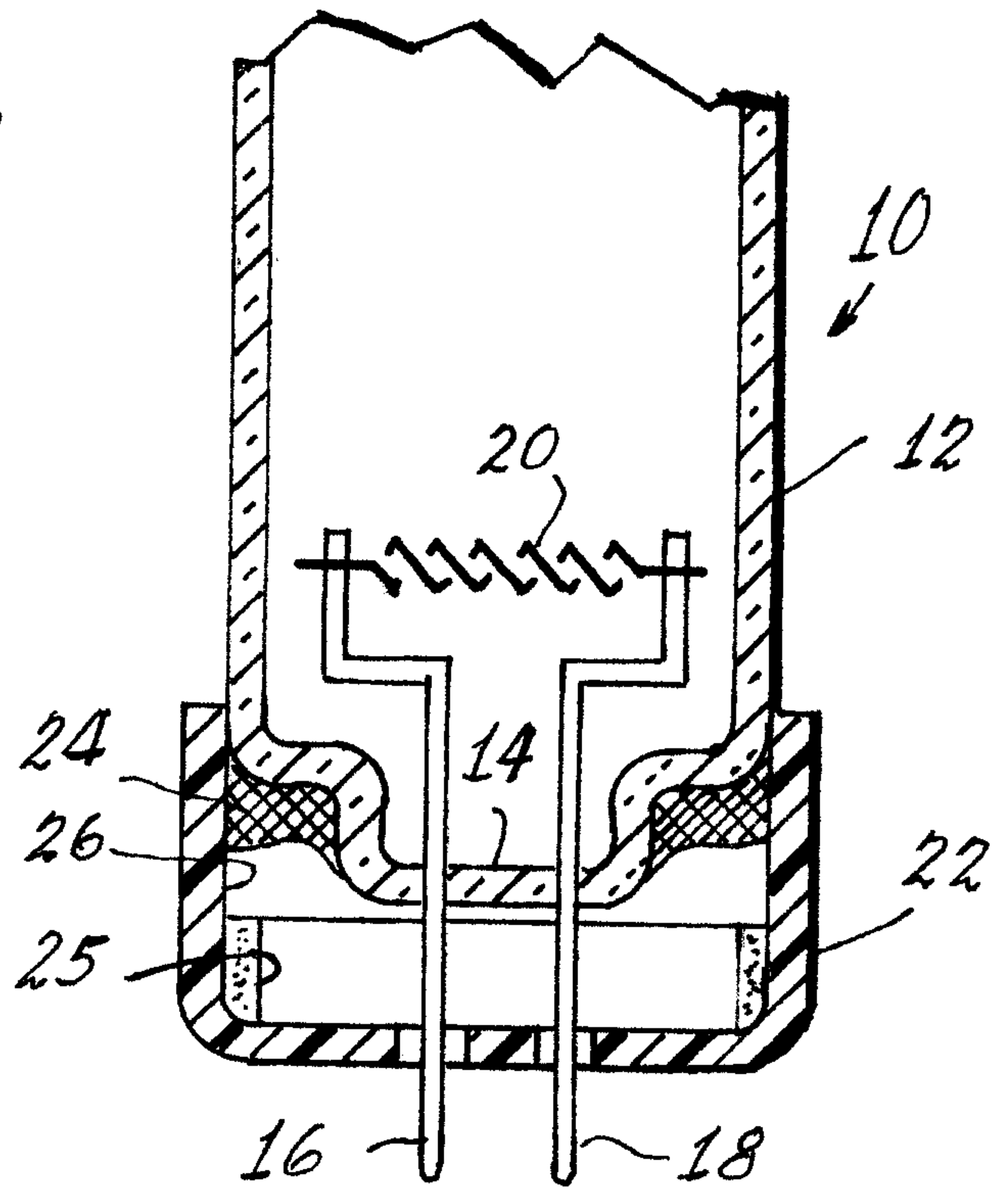

Fig. 4

Patent Agents
Fetherstonhaugh & Co.

