

Nov. 30, 1937.

A. A. KELLOGG

2,100,782

SKYLIGHT

Filed April 3, 1937

3 Sheets-Sheet 1

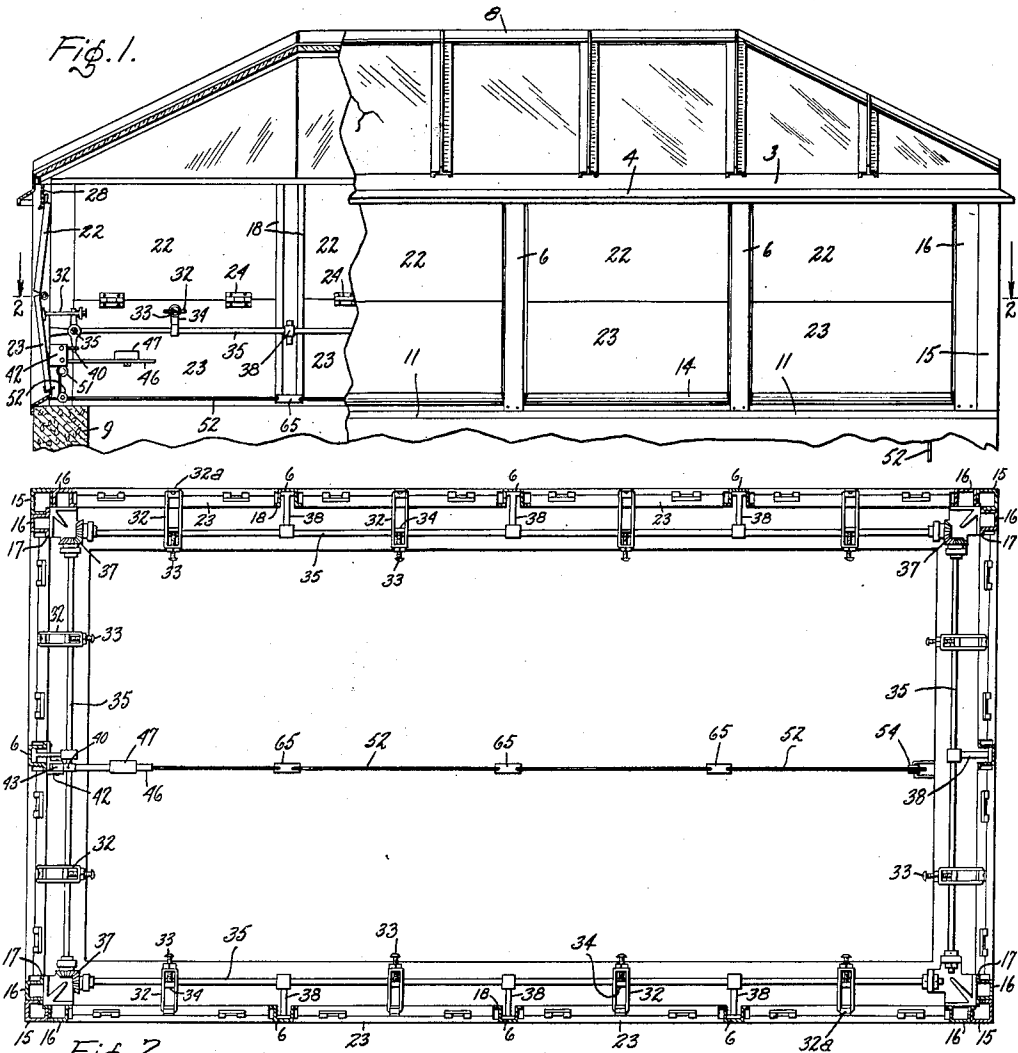

Fig. 2.

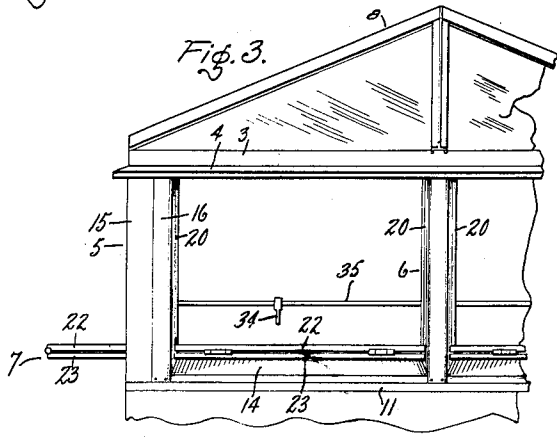

Fig. 3.

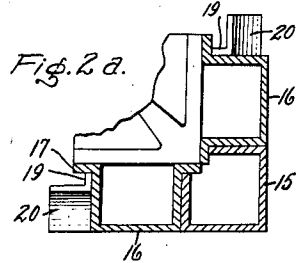

Fig. 2a.

Inventor:  
Alfred A. Kellogg.  
by Alfred V. Robar  
His Attorney.

Nov. 30, 1937.

A. A. KELLOGG

2,100,782

SKYLIGHT

Filed April 3, 1937

3 Sheets-Sheet 2

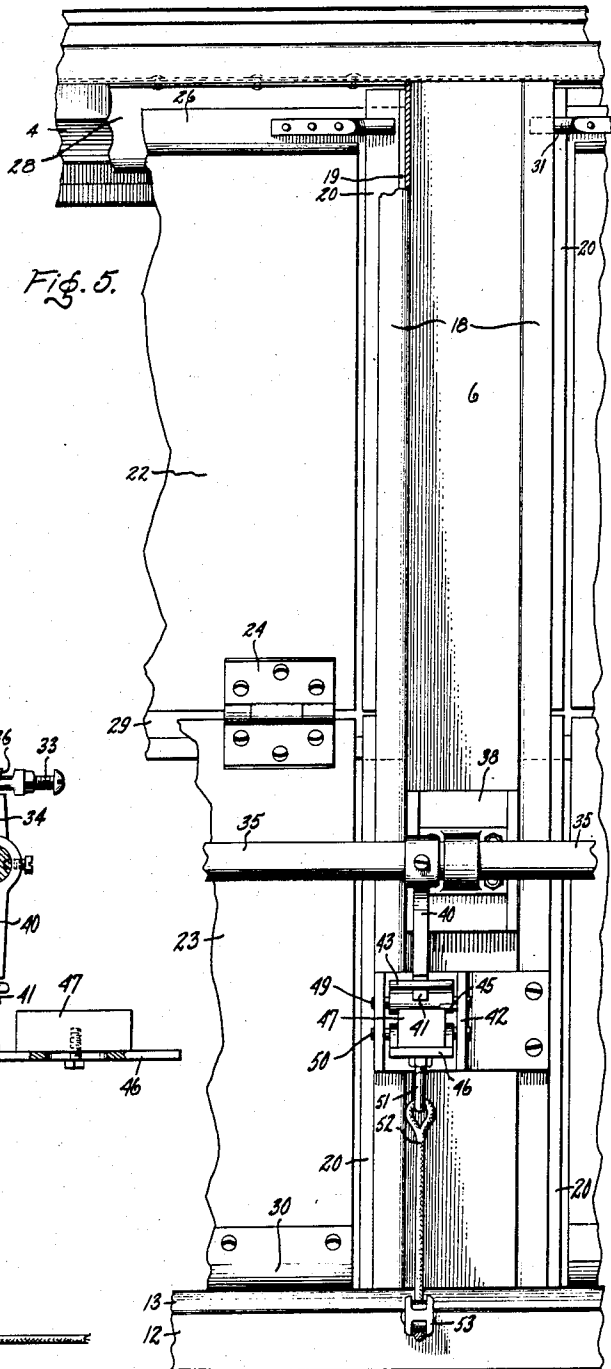
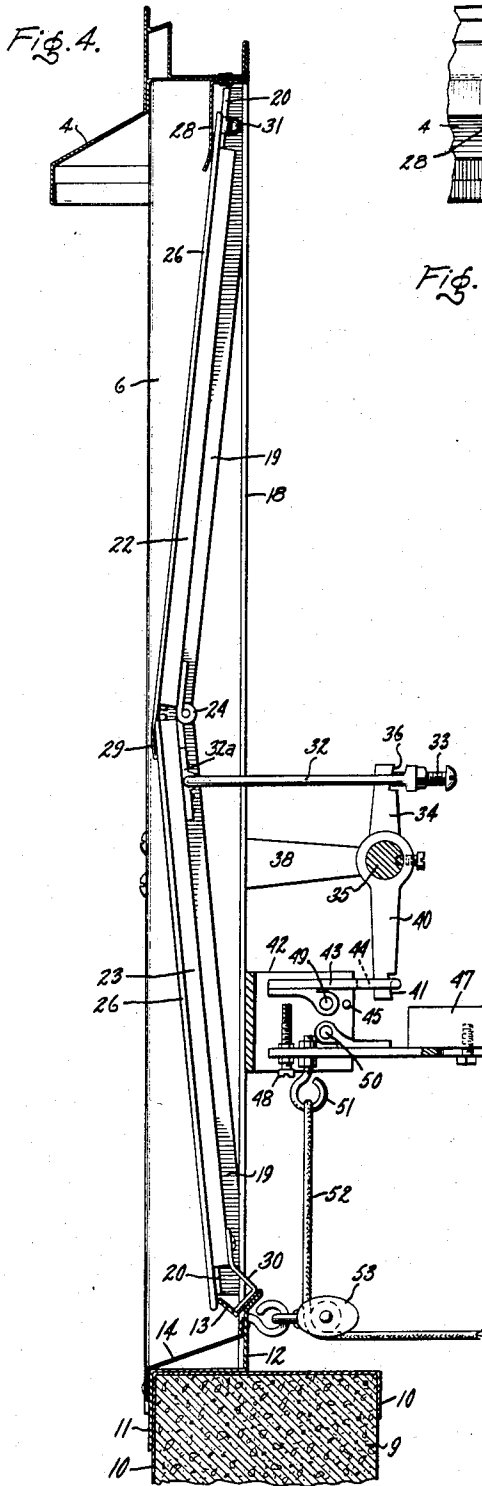

Inventor:  
 Alfred A. Kellogg.  
 by *Alfred V. Bobb*  
 His Attorney.



# UNITED STATES PATENT OFFICE

2,100,782

## SKYLIGHT

Alfred A. Kellogg, Troy, N. Y., assignor to James Ackroyd and Sons, Albany, N. Y., a corporation of New York

Application April 3, 1937, Serial No. 136,055

7 Claims. (Cl. 108—16)

The present invention relates to skylights and especially to skylights of the type which are placed over the stages in theatres, auditoriums or similar buildings and have sash or shutters which are normally closed but are opened in case of a fire to provide a vent for directing the path of the fire. When the shutters are opened, a draft is created tending to carry away the smoke and flames over the stage and confine the fire, at least initially, to the stage, thus preventing its spreading over the seating space of the building.

Heretofore, in structures of this type the shutters, in general, have been held shut by ropes which are cut, in case of fire, to permit the shutters to open. Such arrangements are open to the objection that it is difficult to keep the shutters closed tight. Often the ropes stretch permitting the shutters to open slightly so that snow, rain or cold can enter. Also, such arrangements present an unsightly appearance because of the number of relatively heavy ropes required.

One object of my invention is to provide an improved construction and arrangement in a skylight of this type wherein the shutters are held always tightly closed and are not likely to get out of adjustment and open slightly.

Another object of my invention is to provide a structure whereby the shutters can be easily and accurately adjusted to closed position.

A further object of my invention is to provide an improved structure which is relatively simple in construction, reliable in operation and capable of being built at low cost.

For a consideration of what I believe to be novel and my invention attention is directed to the following specification and the claims appended thereto.

In the drawings which show one embodiment of my invention, Fig. 1 is a side elevation, partly broken away at one end, of a complete skylight, the shutters being closed; Fig. 2 is a sectional view taken on line 2—2, Fig. 1 looking in the direction of the arrows; Fig. 2<sup>a</sup> is a detailed sectional view of a part of one of the corner posts; Fig. 3 is a side elevation of a portion of the skylight showing the shutters open; Fig. 4 is a view, on an enlarged scale, of the shutter shown at the left hand end of Fig. 1; Fig. 5 is a face view of a portion of two adjacent shutters, looking toward the inside of the skylight, i. e., toward the left in Fig. 4. Fig. 5<sup>a</sup> is a detail view of the lower portion of Fig. 4 showing the shutter in open position; Fig. 6 is a face view of a releasing mechanism; Fig. 7 is a sectional view taken on line 7—7, Fig. 6; Fig. 8 is a sectional view taken on

line 8—8, Fig. 6; Fig. 9 is a perspective view of a complete skylight; and Figs. 10 and 11 are detail perspective views of certain parts.

Referring to the drawings, Fig. 9, the skylight comprises a rectangular frame having side and end base members 1 and 2 adapted to fit over the curbing on a roof, side and top members 3 and 4, and corner posts 5 which hold the base and top members in spaced relation to each other. Between the top and bottom members in spaced relation to the corner posts and to each other are uprights 6 which serve to divide the sides and ends of the frame into openings or windows in which are located the sash or shutters 7. The top of the frame is closed by a cover or roof 8 of suitable construction. The specific construction of the roof 8 forms no part of the present invention. Accordingly, it is not illustrated and described in detail. The curbing is indicated at 9 in Figs. 1, 4, and 5<sup>a</sup> and the roof flashing which extends up over the curbing is indicated at 10.

The side and end members 1 and 2 are shaped from sheet metal of suitable thickness to give the desired strength, to provide a right angle portion 11 which rests on the outer top corner of the curbing, a vertical portion 12 and an angularly reversely bent portion which provides a seat 13. Also, each member has an angularly extending bracing member 14 suitably attached to it to give it rigidity. The side and end members are fastened to each other and to the corner posts by rivets or other suitable means and they are suitably anchored to the curbing.

As shown in Fig. 2, the corner posts each comprise a rectangular column 15 having two U-shaped side columns 16 fastened thereto. The outer walls of the side columns have outturned flanges 17. The uprights 6 are U-shaped in cross section and have outturned flanges 18. Attached to the side walls of the uprights 6 (see Fig. 11) and to the side walls of columns 16 are angle strips 19 which provide guide walls 20 which slope outwardly from their upper ends downward to about their central portions and then slope inwardly to their lower ends. These guide walls extend throughout the length of the uprights 6 as is best shown in Figs. 4 and 5, and are elbow shaped as is clear from Fig. 4. Thus along the sides of each shutter opening or window are opposed guide walls 20 which are alike in structure and arrangement.

Pivotaly mounted in each shutter opening is a shutter 27 comprising upper and lower halves 22 and 23 hinged together as is indicated at 24 so as to collapse or fold together outwardly in

opening. The general structure of the shutters is best shown in Fig. 11. Each half comprises a body portion 25 having side flanges 26 adapted to close against the guide walls 20. The shutters may be constructed from sheet metal bent to the required form and suitably reinforced to give them the desired strength. The central portion may comprise a suitable heat insulating material as is indicated at 27. The upper end of each shutter fits behind a frame strip 28 to make the top tight and the lower end of each shutter engages the outer edge of the strip which forms seat 13. Thus when the shutters are closed they are tightly sealed around the edges. To seal the crack between the two halves of each shutter, the upper half is provided with a downwardly projecting strip 29 which engages the lower half when the door is closed as is shown in Fig. 4.

Attached to the lower edge of each shutter is an angular hinge strip 30 which rests in seat 13. When the shutter is closed the hinge strip occupies the position shown in Fig. 4 and when the shutter is open it occupies the position shown in Fig. 5<sup>a</sup>. Fixed to the upper corners of each shutter is a slide pin or guide bolt 31 which engages the guide walls 20. Thus the guide walls 20 are located between the guide bolts 31 and the door flanges 26. When the shutters are closed as shown in Fig. 4, the two halves of each shutter stand at a slight outward angle to each other and due to their weight tend to collapse outwardly, the two halves folding together as shown in Figs. 3 and 5<sup>a</sup>. Thus the shutters are biased toward open position.

Each shutter is held closed by a rectangular bracket 32 pivotally mounted on the shutter at one end as indicated at 32<sup>a</sup> and provided with a threaded opening at its other end in which is an adjusting screw 33. The free end of the bracket 32 fits over the end of an arm 34 fixed on a shaft 35, the end of the adjusting screw engaging with a notch 36 in the end of the arm, see Figs. 4 and 10. There are four shafts 35, one along each side and one along each end of the skylight as shown in Fig. 2. They are connected together at their ends by bevel gears 37 so that all may turn together. The shafts 35 are pivotally supported at spaced intervals by brackets 38, there being a bracket 38 fastened to each upright 6, (see Fig. 2). As will be seen in Fig. 2, there is a bracket 32 for each shutter located at about the middle of the shutter and a corresponding arm 34 on the adjacent shaft 35.

Fixed on one shaft 35, the left hand end shaft in the present instance, is a downwardly projecting trip arm 40 having a notch 41 at its outer end. Fixed to the inner side of the adjacent upright 6 is a bracket 42 on which is pivoted a holding lever 43. One end of holding lever 43 has an opening 44 in which the notched end of trip arm 40 normally rests. At 45 is a stop pin for the holding lever 43. Pivoted to bracket 42 beneath holding lever 43 is a release lever 46 having an adjustable weight 47 at one end and an adjustable screw 48 at the other end which lies beneath the end of holding lever 43. The pivot pin for lever 43 is indicated at 49 and the pivot pin for lever 46 is indicated at 50. Attached to lever 46 adjacent to screw 48 is an eye bolt 51 to which is attached a rope 52. Rope 52 extends down around a pulley 53 fixed to the adjacent wall 12 thence across the skylight (see Fig. 2), over a second pulley 54 at the other side of the skylight and thence downward to a point on the

wall of the building where it is attached to a releasable holder or box 55 (see Fig. 9). Box 55 comprises, as shown in Figs. 6, 7, and 8, walls forming a vertical guide 56 in which is located a slide 57 having an opening 58 in its upper end in which is fastened the end of rope 52. In the box is a lever 59 pivoted to walls of the box at 60. One end of the lever rests normally in an opening 61 in slide 57 and the other end rests on the top of a glass window 62 suitably supported over an opening 63 in the box by a flange 64. The weight 47 on lever 46 to which one end of rope 52 is fastened tends to pull rope 52 and slide 57 upwards and hence the slide normally pulls upward on the one end of lever 59 but the glass window 62 keeps the lever from turning. It will thus be seen that the window holds the weighted lever 46 in the position shown in Fig. 4. In rope 52 are a number of fusible links 65. Suspended from box 55 is a hammer 66 which may be used for breaking glass 62.

Normally the shafts 35 are all held stationary by holding lever 43 which engages trip arm 40, and when held in this position the arms 34 all extend vertically upward and are likewise held stationary. Now by adjusting the screws 33 each shutter can be individually pulled shut tight and each will be held shut independently of the others and also independently of the rope 52. This latter is especially important for even though the rope stretches it will not affect the adjustment of the shutters. Also, the arrangement has the advantage that it permits the use of a relatively light weight rope.

To effect the opening of the shutters in the case of a fire, it is necessary only to break the glass 62 thus releasing the slide 57. This may be done by any suitable implement such as, for example, the hammer 66 shown hung from the box 55. When the slide is released, weight 47 turns lever 46 bringing the end of screw 48 up against lever 43 and turning it to release arm 40. This releases the shafts 35, permitting all the shutters to open. In opening, the shutters move from a position as shown in Fig. 4 to the position shown in Figs. 3 and 5<sup>a</sup>, hinge strip 30 turning in seat 13. The shutters are guided in their closing movement by guide walls 20 along which the guide bolts 31 slide.

Similarly, the weighted lever 46 will be released to effect opening of the shutters in case one of the fusible links 65 is melted.

As pointed out above, each of the shutters is adjusted to closed position by its adjusting screw 33 and when so adjusted it will be maintained in such position. Due to the elbow shape of guide walls 20, the upper and lower halves of the shutters stand always at a slight outward angle to each other. This angle is sufficient so that there is ample force due to the weight of the shutters to cause them to collapse outwardly when released. A space is left between the end of screw 48 and the adjacent end of lever 43 so that any stretching or shrinking of rope 52 will not affect adversely the adjustment of the mechanism. Since rope 52 is required to hold only the weighted lever 46, it may be relatively light in weight. Also, only one rope is required for all the shutters.

In accordance with the provisions of the patent statutes, I have described the principle of operation of my invention together with one embodiment of the invention. It is to be understood, however, that the structure shown is only

by way of example and that the invention may be carried out by other means.

What I claim as new and desire to secure by Letters Patent of the United States, is:

5 1. In a skylight construction, a frame providing a plurality of windows, shutters pivoted in said windows biased toward open positions, a shaft, bearings for the shaft, means normally holding said shaft from turning, an arm on the shaft for each shutter, a bracket attached to each shutter and engaging its corresponding arm to hold the shutter closed, means for adjusting the connection between each bracket and its arm whereby each shutter may be adjusted individually, and means for releasing the shaft holding means to permit the shutters to open.

2. In a skylight construction, a rectangular frame providing windows on its sides, shutters pivoted in said windows biased toward open positions, shafts along the sides of the frame geared together to turn in unison, an arm on the shaft for each shutter, a bracket attached to each shutter and engaging its corresponding arm to hold the shutter closed, means for adjusting the connection between each bracket and its arm whereby each shutter may be adjusted individually, means normally holding said shafts from turning, and means for releasing the shaft holding means to permit the shutters to open.

3. In a skylight construction, a frame providing a window, a shutter pivotally mounted at its lower end in the window comprising two parts hinged together to collapse, means whereby said shutter is biased toward open position, releasable means holding said shutter closed, and independent means for releasing said releasable means.

4. In a skylight construction, a frame providing a window, a shutter pivotally mounted at its lower end in the window comprising two parts hinged together to collapse, a bowed guide wall for the shutter against which it closes and which

serves to hold the two parts of the shutter at an angle to each other whereby they tend to collapse due to their weight, means for holding the shutter closed, and means for releasing said holding means.

5. In a skylight construction, a frame, a shutter pivotally mounted in the frame biased to open position, means holding said shutter closed, a weighted member for releasing said holding means, a rope connected to the weighted member, a casing having a frangible wall and means in the casing to which the rope is connected and which is held against movement by said frangible wall whereby said frangible wall when broken releases the rope and permits the weighted member to release said holding means.

6. In a skylight construction, a frame, a shutter pivotally mounted in the frame biased to open position, means holding said shutter closed, a weighted member for releasing said holding means, a rope connected to the weighted member, a lever, one end of which is connected to said rope, and a frangible member supporting the other end of the lever which when broken releases the rope and permits the weighted member to release said holding means.

7. In a skylight construction, a frame providing a plurality of windows, shutters pivotally mounted at their lower ends in the windows, each shutter comprising two parts hinged together, outwardly angled guide walls for the shutters against which they close and which serve to hold the two parts of the shutters at an angle to each other whereby they tend to collapse due to their weight, pivoted shaft means, releasable means holding the shaft means from turning, arms on the shaft means, adjustable means connecting the shutters to the arms for holding them closed, and means for releasing the shaft holding means.

ALFRED A. KELLOGG.