

(19) World Intellectual Property Organization
International Bureau



(43) International Publication Date
2 September 2010 (02.09.2010)

(10) International Publication Number
WO 2010/098817 A1

(51) International Patent Classification:
A61B 17/80 (2006.01)

(21) International Application Number:
PCT/US2010/000427

(22) International Filing Date:
16 February 2010 (16.02.2010)

(25) Filing Language: English

(26) Publication Language: English

(30) Priority Data:
12/380,177 24 February 2009 (24.02.2009) US

(71) Applicant (for all designated States except US): **ORTHOHELIX SURGICAL DESIGNS, INC.** [US/US];
1065 Medina Road, Suite 500, Medina, Ohio 44256 (US).

(72) Inventors; and

(75) Inventors/Applicants (for US only): **LEITHER, Andrew, J.** [US/US]; 229 Buffington Rd., Akron, Ohio 44333 (US). **LEWIS, Derek, S.** [US/US]; 425 Driftwood Courts, Copley, Ohio 44321 (US). **DELIBERTO, Rebecca, F.** [US/US]; 36 Manor Rd., Apt. C, Akron, Ohio 44313 (US). **DEN HARTOG, Bryan, D.** [US/US]; 7745 Cinnamon Ridge Drive, Rapid City, South Dakota 57702 (US). **EDWARDS, Thomas, B.** [US/US]; 2623 Robinhood St., Houston, Texas 77005 (US). **DUTTA, Anil, K.** [US/US]; 3402 Mont Blanc, San Antonio, Texas 78258 (US). **BELL, Robert, H.** [US/US]; 2669 Walnut Ridge, Akron, Ohio 44333 (US).

(74) Agents: **SHUNK, Laura** et al.; Hudak, Shunk & Farine Co. LPA, 2020 Front Street, Suite 307, Cuyahoga Falls, OH 44221 (US).

(81) Designated States (unless otherwise indicated, for every kind of national protection available): AE, AG, AL, AM, AO, AT, AU, AZ, BA, BB, BG, BH, BR, BW, BY, BZ, CA, CH, CL, CN, CO, CR, CU, CZ, DE, DK, DM, DO, DZ, EC, EE, EG, ES, FI, GB, GD, GE, GH, GM, GT, HN, HR, HU, ID, IL, IN, IS, JP, KE, KG, KM, KN, KP, KR, KZ, LA, LC, LK, LR, LS, LT, LU, LY, MA, MD, ME, MG, MK, MN, MW, MX, MY, MZ, NA, NG, NI, NO, NZ, OM, PE, PG, PH, PL, PT, RO, RS, RU, SC, SD, SE, SG, SK, SL, SM, ST, SV, SY, TH, TJ, TM, TN, TR, TT, TZ, UA, UG, US, UZ, VC, VN, ZA, ZM, ZW.

(84) Designated States (unless otherwise indicated, for every kind of regional protection available): ARIPO (BW, GH, GM, KE, LS, MW, MZ, NA, SD, SL, SZ, TZ, UG, ZM, ZW), Eurasian (AM, AZ, BY, KG, KZ, MD, RU, TJ, TM), European (AT, BE, BG, CH, CY, CZ, DE, DK, EE, ES, FI, FR, GB, GR, HR, HU, IE, IS, IT, LT, LU, LV, MC, MK, MT, NL, NO, PL, PT, RO, SE, SI, SK, SM, TR), OAPI (BF, BJ, CF, CG, CI, CM, GA, GN, GQ, GW, ML, MR, NE, SN, TD, TG).

Published:

— with international search report (Art. 21(3))

(54) Title: ORTHOPEDIC PLATES FOR USE IN CLAVICLE REPAIR AND METHODS FOR THEIR USE

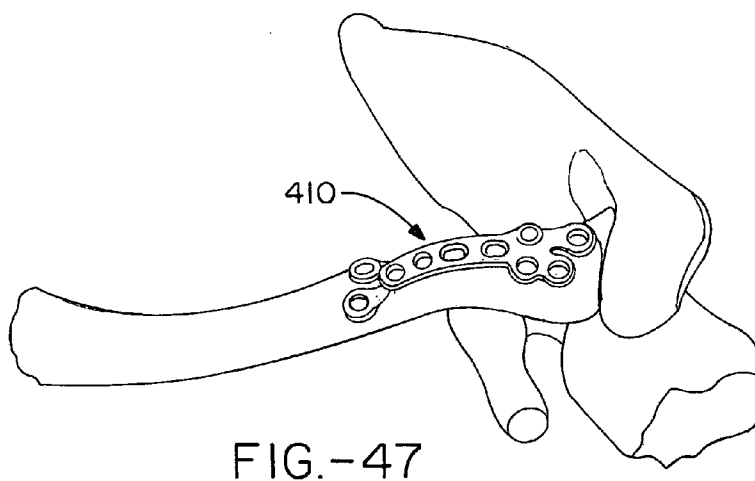

FIG.-47

(57) Abstract: The present invention relates to a series of orthopedic plates for use in repair of a clavicle. The plate has a Y-shaped profile or an X-shaped profile which includes an elongate central trunk with a complex contour and wither one or two terminal pairs of arms that have a first arm and a second arm that form differing angles and lengths relative to the trunk portion of the plate. The arms include locking screw holes where the screws converge toward each other to provide for multiplanar fixation but which do not impinge.

WO 2010/098817 A1

ORTHOPEDIC PLATES FOR USE IN CLAVICLE REPAIR AND METHODS FOR THEIR USE

CROSS-REFERENCE

[0001] This application is a Continuation-in-Part application based on U.S. Patent Application Serial No. 11/340,028 filed on January 26, 2006 and on U.S. Provisional Application Serial No. 60/648,364 filed on January 28, 2005.

FIELD OF THE INVENTION

[0002] The present invention relates to orthopedic plates in particular for surgical repairs or reconstruction of a clavicle and to a method for the use of these plates.

BACKGROUND OF THE INVENTION

[0003] The field of orthopedic medicine has grown tremendously in the past fifty years as surgical techniques, implants and instrumentation have developed and been improved. The small bones are frequently subject to the need for reconstructive surgery for example, as a result of trauma, to counteract the effects of aging or to repair congenital deformities and trauma and spinal areas. While there is a wide variety in the exact shape and mass of all bones, these variations become more problematic in providing orthopedic implants for small bone applications since there is less room on and about the bone for the surgeon to place and fix the construct. These bones are finer and have less surface area for placement of an implant, have less mass for the placement of screws and are often surrounded by less muscle and by more vulnerable tendons, blood vessels and nerves. As a result, individual variations become more problematic for

orthopedic plates of stock design. Consequently, surgeons have tended to rely on the use of screws and wires for reconstruction or have had to resort to operating room contouring procedures which can weaken the plates and/or distort the screw holes within the plates. This is a particular problem in instances in which either variable locking mechanisms are used, or in which locking screws are used with the plates. None-the-less, locking screws often are used to advantage as they provide more secure placement of the screws in the bone, cause better compression through a fractures, and are less likely to harm the bone or back out of the plate.

[0004] One problem that needs to be avoided in the delicate environment of the small bone area is the interference of screws, with other screws, and with the function of ligaments and tendons. While it may be desirable to design an orthopedic plate so that securing screws converge in order to cause compression or increase the pullout strength, it is difficult when a screw impinges on or conflicts with the desired placement of another screw. Some surgeons prefer bicortical fixation in which a screw is sized so that the distal end is secured in cortical bone giving the screw better purchase, however, other surgeons may prefer to avoid placing a screw so that it projects beyond the outer surface of the anchoring bone. These factors are complicated by the relative lack of soft tissue and the presence of ligaments and tendons in the small bone areas. Consequently, the less forgiving biological environment in which the small bone surgeon works requires greater procedural precision and calls for specialized implants and tools.

[0005] The present invention is designed to meet the specific needs of the small bone surgeon to facilitate effective and repeatable procedures which provide for ease of use and a range of function for this specific area of specialization. The present invention is specifically intended to provide for the treatment of fracture repair following trauma in an otherwise healthy individual where plates are used to maintain the integrity of the bones while they heal,

although it is certainly possible that they may also be used for other surgeries such as reconstruction to correct congenital or age related deformation or issues that relate to prior mal-union of the bone following a prior injury.

[0006] The plates of the present invention are designed specifically for the repair or reconstruction of a clavicle, which is commonly called a "collarbone". The collarbones, like the cheekbones, are covered only by skin, and thus have a high correlation to the appearance of the individuals and serve in many cultures as a marker of beauty. These bones further serve to protect the brachial plexus and the medial nerve and blood vessels that are immediately internal to them. They also serve as a strut and the only skeletal connection between the arms and the torso, and they play a very sophisticated role in the functioning of the shoulder girdle, torso, scapular and arm kinesiology. The effect of misalignment and mal-union of clavicle fractures are only recently being examined from the viewpoint of the strength and stamina of the patient as it was previously viewed radiographically and therefore underestimated.

[0007] It has been reported that as many as 5% of all fractures seen in the admissions department of an emergency room are clavicle fractures, which occur most commonly between the proximal 2/3 and the distal 1/3 of the bone. The more common fracture (approximately 80% of clavicle fractures) occurs in the middle third of the clavicle with an upward displacement of the proximal fragment of the bone by the sternocleidomastoid muscle. The weight of the shoulder muscles and of the adductor muscles of the arm may add to the fragment displacement, causing the shoulder to droop. This type of fracture often occurs as a result of a fall on an outstretched hand or of a direct blow to the clavicle. The second most common fracture (which may account for 10-15% of clavicle fractures) occurs in the distal 1/3 of the clavicle. The causes of the fractures are similar to those for the mid-shaft fractures, but also commonly include blows to the shoulder region, such as occur in automobile collisions and particularly physical sports such as hockey, lacrosse and football. Medial fractures are often

associated with very severe trauma that includes injury to the vital organs and other indications of co-morbidity.

[0008] It is often difficult to reduce and subsequently to maintain the reduction of clavicle fractures without surgical intervention, although both union and healing proceeds rapidly, usually with the result of a prominent callus, and in some cases of mal-union, with the possibility of medial cord nerve symptoms. In the past, non-surgical treatment has often involved immobilization of the associated limb, such as in a figure-of-eight bandage or a simple sling. In a study published in the *Journal of Bone and Joint Surgery*, 2006 (88:35-40), by McKee et al, *Deficits Following Non-operative Treatment of Displaced Mid-shaft Clavicle Fractures*, the authors in particular note that that there was a substantial loss of strength and endurance in clavicle fractures treated with a traditional sling approach, indicating substantial residual disability despite apparently adequate range of motion. This and other studies have led to increased concern about providing wider range of surgical options for internal stabilization of the clavicle. However, the problem remains that the shape and size of clavicles vary greatly and their visibility leaves little room for plates that do not generally accommodate this variation gracefully.

[0009] The present invention provides answers to the prior art issues by providing a variety of plates with varying footprints that share an elongate central trunk with a medial line (which is intended in this instance to include a curving line) that divides the plate in half laterally. The plate further has at least one pair of terminal asymmetrical arms that extend from the trunk at differing angles relative to the medial line and have differing lengths. The plates also have varying profiles (or contouring) in the z direction but again share a transverse curve along the medial line about the side which faces the bone. The plates also all exhibit bilateral asymmetry (meaning that the left half of the plate is not exactly the same as the right half of plate taken from the medial line) and they all achieve bi-planar screw fixation (meaning that the screws do not lie in a single plane). In

addition, while the plates are pre-contoured, the plates are designed to facilitate three dimensional contouring (at least in the terminal arms) to accommodate individual variation in bone shape. The plates are configured to bend laterally, longitudinally, and to wrap or spiral about the longitudinal axis or medial line so that they can be molded to an optimal shape for small bone procedures. The plates are designed to provide optimal stabilization of fractures and osteotomies by providing multi-planar fixation that allows for better pull-out and limited axial loading to the bone. The plates are further designed to accelerate fusion success by reducing or eliminating torsional or twisting stresses to the bone segments during the healing process. In addition, when desired, the plates can be shaped so as to apply a compressive, or even a tensile, force, for example, along the longitudinal axis of a bone.

[0010] These plates are provided in a number of variations in a surgical tray, which include for example various lengths of the central trunk portion, which is provided with a line of screw holes centered along the medial line. Further the number of screw holes in the trunk can vary, and the type of holes can vary to include translation slots, compression slots, and locking and non-locking screw holes. Thus, the tray selection allows the surgeon to select his plate during surgery after opening the wound area and considering the plating needs. In addition, the tray includes plates of differing types for differing placement on the clavicles. In a first embodiment of the clavicle plate of the present invention, a plate is provided for placement on the superior aspect of a clavicle, and in a second embodiment, a plate is provided for placement on the anterior/inferior aspect of a clavicle, and in a third embodiment, a plate is provided for placement on the lateral aspect of a clavicle.

[0011] All of the plates have an elongate central trunk portion including one or more screw holes which are optionally separated by a waist shaped linking portion along a longitudinal axis or the medial line and depending on the embodiment, the plate has one pair or two pairs of arms which are preferably

terminal to the central trunk, and which include screw holes (i.e. one per arm) placed at an equal distance from the longitudinal axis but which diverge asymmetrically from the longitudinal axis to avoid conflicts in the screw placement of the paired arm, specifically, so that the screws of a set of arms avoid impinging on each other and further to provide multiplanar fixation at the plate terminus. The plate is curved about the inferior surface, (i.e. the surface which faces toward and which may, but does not have to fully contact the bone), with a curvature corresponding generally to the curvature of a bony surface. In most of the embodiments of the plate this contouring is the result of a blending of one or more series of radiuses so that the plate may comprise a portion of a cylinder, or portions of a cylinders, or in the event that the medial line also defines a longitudinal curve in the z axis, a portion of a torroid. The pair of arms continue this curvature to spiral or wrap around the bone like a small portion of a double helix (i.e. extending through an arc of less than about 50°). The screw holes within the arms are placed so that the angle of the longitudinal axis of the screws converge in the direction of the distil end of the screw. The screw holes are placed with the longitudinal axis perpendicular to a tangent to the top surface of the arm with the effect that the longitudinal axes of the screws converge in the direction of the distil end. The convergence of the screw holes increases the pull-out strength of the screws.

[0012] Further the screw holes are rounded and the corresponding mating heads of the screws are rounded and have a low profile so that the screws can be seated with their longitudinal axes at a variety of angles. Preferably, there is at least 20° of conical rotation, and more preferably 25°, and most preferably 30° of conical rotation of the screw axis in relation to the longitudinal axis of the screw hole (i.e. the longitudinal axis of the screw can be rotated through a conical shape about the axis of the screw hole where the apex of the cone describes an angle of 30°). Alternatively and in many cases, preferably, the screw holes can include internal threads which mate with external threads on the head of the screws to cause locking of the screws relative to the plate.

[0013] While the screws are at convergent angles, the screws typically do not in fact impinge on each other, or conflict in their placement since each of the arms of the plate in a pair form a different angle to the central trunk so that the longitudinal axis of the screws are offset from each other along the length of the plate. The radiused configuration of the plate is designed to increase operating room efficiency by facilitating commonly desirable shapes while maintaining the required strength and by permitting bending without deforming the screw holes. This results in making customization in anticipation or during surgery easier.

[0014] The surgical tray of the present invention further includes a variety of screws. The screws useful with the plate of the present invention are self-starting, self-tapping screws including the option of partial or full cannulation. The screws include a unique cutting end having multiple flutes, and preferably 2 or 3 flutes about a conical recess. The screws further include a partial taper of the inner diameter in the proximal end over the first several thread turns, for example over 2-8, and preferably over 3-5 turns in order to increase the fatigue life of the screw as well as providing potential physiological advantages in use. The screws further include a torque driving recess that may be a hexagon, a torx shape, or a modification of a torx shape, i.e. a multilobe shape having from 3 to 12 lobes, and preferably having 4 to 8 rounded recesses or lobes. The recess can be of a constant size in the direction of the longitudinal axis, or can taper inward along the longitudinal axis of the screw toward the bottom of the recess. The screws have a low profile, head which is rounded at the junction of the head and the shaft, and also rounded from the maximum diameter toward the top surface or the proximal end relative to the insertion tip, which includes the torque driving recess. This rounded low profile head keeps the screw from having any sharp projecting edges which could provide an irritation to the tissue in the vicinity of the plate and further seats in the plate so that no more than 10% by volume of the screw head projects from the plate.

[0015] The instruments for use with the system are well-balanced and ergonomically designed with sufficiently long handles to place the surgeon's hands outside of the line of radiation and designed to reduce fatigue in the operating room.

[0016] Depending on the intended placement of the plate, the central trunk, and the plate itself includes a general topography (i.e. the contour in the z direction) designed to maximize the fit on a variety of shapes and sizes of clavicle while enabling, but reducing the need for individualized contouring. This topography includes a c-shape lateral curve in the superior and 4-hole anterior plates, a fishtail (i.e. having a broad curve in the direction of the bone-facing surface of the plate terminating in a short up-turned curve at the end of the plate) shape in the longer anterior plates. The lateral plate has an S-curve of the medial line in the direction of the width of the plate. The plate system of the present invention is thus designed to fit a range of needs of the surgeon operating on the clavicles to allow him or her to perfect a variety of techniques using a set of instruments and a customizable plate and screw construct.

BRIEF DESCRIPTION OF THE DRAWINGS

[0017] Figure 1 is a top view of a first embodiment of an orthopedic plate in accordance with the invention;

[0018] Figure 2 is a cross-section of the plate of Figure 1 taken along line 2-2;

[0019] Figure 3 is a cross-section of the plate of Figure 1 taken along line 3-3;

[0020] Figure 4 is a cross-section of the plate of Figure 1 taken along line 4-4;

[0021] Figure 5 is a cross section of the plate of Figure 1 taken along line 5-5;

[0022] Figure 6 is a perspective view of a screw used with the present system;

[0023] Figure 7 is a perspective view of a locking screw used with the present invention;

[0024] Figure 8 is a top view of a first version of a second embodiment of the plate in accordance with the invention;

[0025] Figure 9 is a cross section of the plate of Figure 8 taken along line 9-9;

[0026] Figure 10 is a mirror version of the plate shown in Figure 8;

[0027] Figure 11 is a cross section of the plate of Figure 10 taken along line 10-10;

[0028] Figure 12 is an end perspective of a left version of a third embodiment of a plate in accordance with the invention for placement on the anterior aspect of a clavicle;

[0029] Figure 13 is a top view of the plate of Figure 12;

[0030] Figure 14 is a right end view of the plate of Figure 12;

[0031] Figure 15 is a right side view of the plate of Figure 12;

[0032] Figure 16 is a cross section of the plate of Figure 12 taken across the width of the plate;

[0033] Figure 17 is view of the plate of Figure 12 placed on a clavicle;

[0034] Figure 18 is an end perspective of a left version of a fourth embodiment of a plate in accordance with the invention for placement on the anterior aspect of a clavicle;

[0035] Figure 19 is a top view of the plate of Figure 18;

[0036] Figure 20 is a right end view of the plate of Figure 18;

[0037] Figure 21 is a right side view of the plate of Figure 18;

[0038] Figure 22 is a cross section of the plate of Figure 18 taken along line 22-22;

[0039] Figure 23 is view of the plate of Figure 18 placed on a clavicle;

[0040] Figure 24 is a top view of a left version of a fifth embodiment of a plate in accordance with the invention for placement on the anterior aspect of a clavicle;

[0041] Figure 25 is an end perspective of the plate of Figure 24;

[0042] Figure 26 is a right end view of the plate of Figure 24;

[0043] Figure 27 is a right side view of the plate of Figure 24;

[0044] Figure 28 is a cross section of the plate of Figure 24 taken along line 28-28;

[0045] Figure 29 is view of the plate of Figure 24 placed on a clavicle;

[0046] Figure 30 is an end perspective of a left version of a sixth embodiment of a plate in accordance with the invention for placement on the superior aspect of a clavicle;

[0047] Figure 31 is a top view of the plate of Figure 30;

[0048] Figure 32 is a right end view of the plate of Figure 30;

[0049] Figure 33 is a right side view of the plate of Figure 31;

[0050] Figure 34 is a cross section of the plate of Figure 30 taken along line 34-34;

[0051] Figure 35 is view of the plate of Figure 30 placed on a clavicle;

[0052] Figure 36 is an end perspective of a left version of a seventh embodiment of a plate in accordance with the invention for placement on the superior aspect of a clavicle;

[0053] Figure 37 is a top view of the plate of Figure 36

[0054] Figure 38 is a right end view of the plate of Figure 36;

[0055] Figure 39 is a right side view of the plate of Figure 36;

[0056] Figure 40 is a cross section of the plate of Figure 36 taken along line 40-40;

[0057] Figure 41 is view of the plate of Figure 36 placed on a clavicle;

[0058] Figure 42 is an end perspective a left version of a eighth embodiment of a plate in accordance with the invention for placement on the lateral aspect of a clavicle;

[0059] Figure 43 is a top view of the plate of Figure 42

[0060] Figure 44 right end view of the plate of Figure 42;

[0061] Figure 45 is a right side view of the plate of Figure 42;

[0062] Figure 46 is an right end view of the plate of Figure 42; and

[0063] Figure 47 is a view of the plate of Figure 42 placed on a clavicle;

DETAILED DESCRIPTION OF THE INVENTION

[0064] The plate 10 of the present invention is shown having a bilaterally asymmetric shape with either one or two pairs of legs extending from a central trunk portion 12 defining the longitudinal axis of the plate. As shown the trunk portion 12 includes two screw holes or slots 14 along the longitudinal axis. However, as can be seen from Figures 12 through 18 the plate can be presented in a version which has a plurality of screw holes, for example up to 8 or more. The number of screw holes in the trunk portion 12 will depend on the length of the plate, and may range from 0 to 8, and more preferably from 2 to 4. In one embodiment these holes are compression holes or translation slots. The compression holes 14 are preferably slotted or elongated and optionally may have a larger radius area 11 on each of the screw holes facing in the same direction, and a smaller radius area 13 in order to induce a compression toward the smaller radius end. The holes may also or alternatively have a shallow shoulder or lip 18 which descends toward the inferior surface of the plate to allow the plate to be set initially and subsequently to be slide into a different position as

the screws are tightened down. This allows compression to be applied across the middle of the trunk section. The plates include a visual indicator of the direction of the compression, such as an arrow 17. Further, the screw holes can include annular rings of increased thickness in the vertical direction about through holes 14.

[0065] The through holes 14 in the trunk portion 12 have a longitudinal axis that is perpendicular to plane tangent to the top radius of the plate. The area linking the screw holes has a decreased width so as to define a waist area 26 that will bend laterally (or "curve") relative to the longitudinal axis and which will bend longitudinally to form a curved area in and out of the plane of the plate. This thinner area also facilitates twisting of the plate so as to allow the plate to spiral, or wrap around its longitudinal axis. The increased annular area around the through bores resists deformation when a bending device is used to apply a force to the plate through the screw holes.

[0066] The plate 10 also includes at least one set of arms 20. As viewed in Figure 1, these sets of arms can be viewed as a set of a short arm 22 and a long arm 23. Each of the arms in a set includes screw holes 24 which are placed at a radially equal distance but which diverging asymmetrically from the longitudinal axis of the plate 10. More specifically, each set of arms includes one arm that defines a smaller angle of divergence α from the longitudinal axis of the trunk portion than the angle of divergence of the other arm β . For example, the first angle shown in Figure 1 at α may be from about 5° to about 25° , and more preferably from about 10° to about 20° and most preferably from about 12° to about 16° , while the second angle shown at β from about 10° to about 35° , and more preferably from about 15° to about 30° and most preferably from about 22° to about 26° with a preferred difference in the angles being from about 2° to about 20° , and more preferably from about 4° to about 16° and most preferably from about 8° to about 12° .

[0067] In addition to the angled arms of this asymmetrical shape facilitating a variety of useful positions in the small bone area, the plate of the present invention is sized to fit the needs of the small bone specialist. For small bone usage, the total length of the plate along its longitudinal axis is from about 25mm to about 80mm, depending on the number of screw holes in the trunk portion. The total width is from about 12mm to about 18mm, with an inferior radius of curvature of about 8mm to about 12mm and a concentric radius on the superior side. Typically, the waist area measures from about 7.5mm to about 10mm from the center of the larger, i.e. about 3.8mm, radiused portion of the holes. The trunk portion has a width of about 7mm to about 9mm wide at the wider parts and about 3mm to about 5mm wide at the narrower waist portion. The longer arm has a length along the longitudinal axis of the plate from the center of the screw hole to the center of the plate for a two-hole trunk of from about 12mm to about 16mm, with a width of about 3mm to about 5mm. The shorter arm has a comparable length of from about 7mm to about 15mm with a narrowed width of about 2.5 to about 5mm. In a further embodiment the plate could be modified for use in the long bones with a length of up to about 400mm with a width of up to about 50mm, and proportional sizes for the arms and thickness.

[0068] On the inferior side, or the side that would be facing (which contemplates opposing or touching or partially touching the) bone surface in use, the arms continue the radius of curvature of the trunk portion. The superior or top side of the plate has a similar radius of curvature as the top surface of the plate has an outline that corresponds with the shape of the bottom of the plate (excluding the optional thickened annular area surrounding the screw holes which would act to shield these holes against deformation during bending.) The screw holes also include a rounded concavity to mate with the rounded shape of the head of the screw to allow of variable axis positioning. The screw holes 24 are placed with the longitudinal axis perpendicular a tangent to the top surface of the arm with the effect that the longitudinal axes of the screws converge in the direction of the distal end. This increases the pull-out strength of the plate/screw

construct. Since the arms are asymmetrical relative to each other, and in particular since they diverge from the longitudinal axis of the trunk portion at differing angles, conflicts in the positions of paired screws is avoided so that the screws of a set of arms typically do not impinge on each other. This is even more important in instances where the plate is bent around the longitudinal axis so as to wrap around the longitudinal axis of the bone.

[0069] The arms 20 also each include a screw hole 24 which, like the trunk portion 12 has a linking portion 26 that joins the screw hole to the trunk portion. Again this design facilitates the desired bending while resisting deformation of the screw holes 24 when they are used with the bending instrument to contour the plate. The angle of the arms 20 of each one of a pair of arms (both top and bottom and right and left pairs) varies so as to create a bilateral asymmetry, meaning that the plate is not symmetrical with respect to a plane that passes through the longitudinal axis in the vertical direction from the superior (the top side relative to the bone) to the inferior side (the side facing the bone), the "first plane".

[0070] The screws holes of the trunk portion can include means to induce a compressive force in one direction, such as a ramped area on each screw hole. These ramped areas would be ramped on the same side of the holes looking down from the top of the plate. Typically the first screw implanted stabilizes and the second screw is used to achieve compression. Further the length of each of the arms of a pair will vary so that the radial length of the center of the screw hole to the intersection with the longitudinal axis will be the same. As shown in Figures 3-5, the plate includes a radial curve about the longitudinal axis. The radius is typically about 10mm with a transverse dimension from the edge of one arm to the edge of the other arm of a pair being about 15 or 16 mm for typical small bone usage, and the screw bore having a longitudinal axis of about 24° to a plane passing through the longitudinal axis of the plate. The bores are typically about 3.75mm for a 3.5 mm diameter screw for small bones excluding the

smallest of applications which would include phalanges. Again, for the smallest application as well as long bone embodiments the screws and corresponding screw holes could be sized to range from a 1.5mm diameter screw up to a 7.5mm diameter screw. In a further embodiment, the bore could be threaded.

[0071] Figure 6 shows a screw 81 which could be used with the plate system of the present invention. The distal end of the screw can include a cutting tip which is self-starting and self-tapping or a rounded blunt tip. This aspect is defined by a conical recess and a plurality of flutes. These screws 81 can optionally include partial or full cannulation. The head of the screw 82 is spherical and includes a torque driving recess, such as a modified multilobe shape. The screw has a cancellous thread 83 with a constant major diameter and a minor diameter that tapers proximally in order to increase fatigue life of the screw and to improve compression and compensate for bone resorption. Figure 7 shows a locking screw 86 which could be used with the present invention. The screw includes the same features as the screw in Figure 6, except that the screw further includes external threads 88 on the screw head.

[0072] Figures 8 through 11 show a second embodiment of a plate in accordance with the present invention in which the plate shown in Figure 10 is a mirror image of the plate shown in Figure 8. In this embodiment, the plate 71, 71' has a Y-shape with an elongate and cylindrical central trunk having a single pair of arms 72, 72' extending as previously described from the a trunk portion 73, 73'. The trunk portion optionally has one or more compression slots 74, 74'.

[0073] Figures 12 through 17 show an embodiment of the present invention for placement on an anterior aspect of a left clavicle with the version for the right clavicle being a mirror image. This embodiment of the plate 210 has a profile having a central trunk 212 with two sets of terminal arms 220 similar to the plates shown in Figures 1-5 except that the short arms extend away from the same side of the trunk relative to the medial line. Thus, the plate forms an X with

two short arms 213 on the same side and two long arms 214 on the same side and the elongate central trunk 212 bridging the span between each terminal set of arms. The central trunk includes a slight longitudinal curve, and the bottom 227 of the plate has a radial curve as can be seen in the end view of Figure 14, and in the cross-section shown in Figure 16. Thus, the plate forms a segment of a torroid. The trunk includes two translation slots 230, which are obround and in the middle of the plate and which are used for initial fixation and which subsequently allow for translation of the plate relative to that fixation. The plate further includes two screw holes 232 which are shown as locking holes having internal threads. These holes further include keyways 233 for the mating portion of a drill guide in order to set the pilot hole for a locking screw received in these holes.

[0074] The plate 210 has a two pairs of arms 220 that extend as previously described. Specifically, for each pair of arms, each of the first 213 and second arm 214 include a screw hole 235 which defines an axis of the screw (perpendicular to a tangent at the diameter of the screw hole) and the arms have a longitudinal axis which is a line intersecting the screw axis and the longitudinal axis of the central trunk. The arms spiral or wrap around in the same direction that the central trunk does. The screw holes 235 are preferably threaded locking holes, which also include keyways for a drill guide that sets the angle for the locking screw. For each arm, the longitudinal axis defines an angle relative to the longitudinal axis of the central trunk, and the angle is different for one arm than for the other arm in a terminal pair as is shown for the embodiment shown in Figure 1. The plate demonstrates a mirror symmetry about the transverse plane since the two short arms have a corresponding angle, length and shape and the two long arms have a corresponding angle, length and shape.

[0075] As has been previously described, the pair of arms include an inferior curve in the same direction as the radial curve in the central trunk portion. The

difference in the length and angles of the arms allows for multiplanar fixation and convergence of the screws (which are locking screws) while avoiding impingement of the screws with each other. Thus, the plate is designed to fit the lateral 2/3 of the clavicle and the arms are designed wrap around the shaft of the bone. The plate is shown with a central trunk that includes two obround slots in the central trunk and two locking screw holes that include internal threads and keyways for a drill guide to set the angles for the screws. The plate also includes two terminal sets of arms each having a short arm and a long arm with the short arms on the same side for ease of insertion through the incision. The plate can have one or no slots and from 1 to 8 screw holes. Figure 17 illustrates the placement of the plate on the anterior/inferior aspect in the mid-shaft portion of a clavicle

[0076] Figures 18-29 show two slightly different embodiments of the plate of the present invention which vary according to the length of the elongate central trunk and accordingly, to the number of screw hole in this section of the plate. However, in both versions, the plate 310, 310' has a y-shaped footprint which comprises an elongate central trunk 312, 312' having a medial line and along the medial line, through holes, (which can either be slots 316, 316' such as compression slots or translation slots) and/or screw holes 317, 317' (which can either be smooth for variable locking or threaded for locking holes). In these embodiments, the holes of the central body are aligned with their centers along a straight medial line (or in this instance a plane), which divides the plates in two lateral halves. The area between the through holes curves inward toward the medial line to allow the plate to be further contoured without deforming the holes.

[0077] One end of the central trunk includes a single pair of arms 320, 320' with a longer arm extending at a first angle from the medial line of the plate and having a shorter length than the second arm which extends from the plate at a second angle and has a longer length. The arms include a rounded portion 324, 324' that defines a portion of a circle and has a linking area that has a smaller

width than the diameter of the circle. Each rounded portion includes a screw hole 326, 326' may advantageously include internal threads 328, 328' and keyway grooves 329, 329' for a drill guide. These embodiments of the plates are provided in a first version having five locking holes 317, in the central trunk and three obround translation slots 316. The translation slots 316 may include contouring with in the lateral edges of the slot that are convex to receive the rear shoulder or rounded portion of the screw in order to cause the screw to seat in the plate perpendicularly to the medial line. The plate is provided in a right and a left version and the left version is illustrated in the figures. In this version, the plate is curved along the medial line transverse to the medial line as can be seen in Figures 20 and 22. The plate also includes a larger contouring which is like the shape of a fishtail in that it bows gently from the end with the pair of arms in a first direction for approximately the first $\frac{3}{4}$ to $\frac{9}{10}$ of the length of the plate, and then curves more sharply in the opposite direction along the z axis.

[0078] In the longer version of this plate 310', the plate includes four obround translation slots 316' which are in the center between three locking screw holes 317' at the end with the arm 320' and four locking screw holes 317' at the other end of the central trunk. This plate has similar contouring to the shorter version of this plate, with a radius on the bottom and a fishtail curve with a longer, and shallower curve which defines a curve that bows in a first direction from the arms through the second of the second set of locking holes, and the plate including the last two locking holes defines a curve in the opposite direction. Both of these plates are designed for placement on the middle portion of a clavicle and the choice between the two versions depends on the placement and nature of the fracture involved.

[0079] Figures 30 through 41 illustrate plates that are intended for use on the superior aspect of the clavicle. Again, left versions are shown, with the right version being mirror images of the left version. These plates 410, 410' have elongate central trunk portions 412, 412' with two opposing pairs of arms 420,

420'. Each of the first 413, 413' and second arm 414, 414' of a pair of arms 420, 420' include a screw hole 435, 435' which defines an axis of the screw (perpendicular to a tangent at the diameter of the screw hole) and the arms have a longitudinal axis which is a line intersecting the screw axis and the longitudinal axis of the central trunk as medial as possible to the arm. The arms spiral or wrap around in the same direction that the central trunk does. The screw holes 435, 435' are preferably threaded locking holes, which also include keyways for a drill guide that sets the angle for the locking screw. For each arm, the longitudinal axis defines an angle relative to the longitudinal axis of the central trunk, and the angle is different for one arm than for the other arm as is shown for the embodiment shown in Figure 1. The plates demonstrates a mirror symmetry about the transverse plane since the two short arms have a corresponding angle, length and shape and the two long arms have a corresponding angle, length and shape.

[0080] The central trunk in the two versions shown in Figures 30-41, (with the shorter version shown in Figures 30-35 and the longer version shown in Figures 36-41,) varies by the length and accordingly by the number of through holes in the trunk. In the shorter version, there are two translation slots 416 that are aligned along the medial line and are flanked by a first locking screw hole 417 and a last locking screw hole 417. This area of the plate also includes curves between the screw hole that allow the plate to be contoured without bending the through holes. The plate had a shallow longitudinal C curve in the direction away from the shorter arm side of the plate. The bottom side 427 of the plate also includes a radius to better accommodate the shape of the bone.

[0081] The version of the plate shown in Figures 36-41 has a longer central trunk 412' which includes four translation slots 416' aligned along the medial line and flanked by two locking screw holes 417'. Again, the central trunk portion of the plate curves gently in the direction of the shorter arms and the bottom 427' of

the plate includes a radius. Figure 35 shows the placement of the shorter plate on the inferior spine of a clavicle and Figure 41 shows the placement of the

[0082] Figures 43-47 illustrate a plate for use on the lateral aspect of the clavicle. This plate 510 has an x-shaped profile, with an elongate central trunk and a first pair of arms 520 which extend at different angles and for different lengths from the trunk and further which include a curve on the bottom side so that the arms spiral around the bone and the screws that are placed in screw holes 535 in the arms provide for multiplanar fixation and do not impinge on each other. The central trunk includes two translation slots 516 and two locking screw holes 517 in the proximal end of the plate (i.e. adjacent to the end with the pair of arms 520). The other end of the plate includes a pair of arms 530 that differs from the other pairs in that there is a necked transition area 531 including screw holes 532 that are aligned with the terminal screw holes 533 in these arms. There is again a shorter arm 540 and a longer arm 541, which include threaded locking screw holes and keyway guide grooves. The plate has a shallow S shape along the medial line with the more proximal of the two translation slots marking the transition between the lobes of the S. The plate includes a bottom radius. Figure 47 shows the plate in position on the distal portion of a clavicle.

[0083] While in accordance with the patent statutes, the best mode and preferred embodiment have been set forth, the scope of the invention is not limited thereto, but rather by the scope of the attached claims.

WHAT IS CLAIMED IS:

1. An orthopedic plate system comprising at least one screw and an orthopedic clavicle plate having an inferior surface which is capable of facing a clavicle bone surface in use and which is pre-contoured to accommodate the shape of that bone surface and an oppositely facing concentric superior surface, the plate having a central trunk portion defining a longitudinal trunk axis extending between a first end and a second end and having at least a portion of the inferior surface which includes a curve transverse to the longitudinal axis, said plate including at the first end a pair of divergent arms which extend so as to form a left arm and a right arm, each arm including an arm screw hole which defines a screw axis that converges toward the inferior surface of the plate and the arm being joined to the trunk portion by a link, each arm of the pair having a longitudinal arm axis which extends between the central screw axis and the longitudinal trunk axis defining an angle with respect to the longitudinal axis of the trunk area and the angle of the left arm being α and the angle of the right arm being β where α is different than β such that the screw axis of the right arm converges toward but does not impinge on the screw axis of the left arm.

2. An orthopedic plate system as set forth in claim 1 wherein the plate includes two pairs of divergent arms and the plate exhibits mirror symmetry about a transverse plane.

3. An orthopedic plate system as set forth in claim 2 wherein the central trunk includes at least one screw hole.

4. An orthopedic plate system as set forth in claim 3 wherein the curve transverse to the longitudinal axis has a constant radius along the longitudinal axis for at least a portion of the length of the central trunk.

5. An orthopedic plate system as set forth in claim 4 wherein at least a portion of the inferior surface forms a segment of a cylinder.

6. An orthopedic plate system as set forth in claim 1 wherein said at least one screw has a threaded shaft and a head and wherein the arm screw hole and the screw head have a mating interface such that the screw can engage the arm screw hole so as to allow a plurality of angular orientations of the screw axis.

7. An orthopedic plate system as set forth in claim 6 wherein the mating interface between the screw head and the arm screw holes allows for at least 30° of conical orientation of the screw axis in the screw hole.

8. An orthopedic plate system as set forth in claim 1 wherein the plate has a medial line which describes an S-curve in the lateral plane or in the longitudinal plane.

9. An orthopedic plate system as set forth in claim 1 wherein the plate has a medial line which describes a C-curve in the lateral plane or in the longitudinal plane.

10. An orthopedic plate system as set forth in claim 1 wherein said at least one screw has a threaded shaft and a head and wherein the arm screw hole and the screw head have a mating interface such that the screw can engage the arm screw hole so as to cause a locked angular orientation of the screw axis in the arm screw hole.

11. An orthopedic plate system as set forth in claim 10 wherein the screw head includes external threads and the arm screw hole includes corresponding internal threads.

12. An orthopedic plate as set forth in claim 11 wherein the system further includes a drill guide and the arm screw hole further includes guide ways for the drill guide which set the angle for the drill guide relative to the plate.

13. A surgical plate system comprising
a pre-contoured Y-shaped plate that has an inferior surface and which has a concentric superior surface, the plate consisting of a trunk and a pair of a first arm and a second arm,

the trunk having a medial line along the superior surface extending between a first and a second end, and the inferior surface of the plate defining a curve transverse to the medial line, the trunk including at least one screw hole and ,

the first arm and the second arm extending from the first end of the trunk, the inferior surface of the first arm and of the second arm spiraling around the medial longitudinal axis of the trunk,

the first arm having an ear with at least one screw hole defining a first screw axis perpendicular to a tangent to the top surface of the first ear, the first ear being attached to the trunk by a linking section having a waist, a first angle and a first length being defined by a line from the center of the first arm screw hole to the intersection of the medial longitudinal axis of the trunk, and,

the second arm having a second ear with at least one second screw hole defining a second screw axis perpendicular to a tangent to the top surface of the second ear, the second ear being attached to the trunk by a linking section having a waist, a second angle and a second length being defined by a line from the center of the second arm screw hole to the intersection of the medial longitudinal axis of the trunk, and

the first angle and the first length being different from the second angle and the second length whereby the first screw axis and the second screw axis converge toward the inferior side of the plate but do not intersect to allow for multiplanar fixation .

14. A surgical plate system as set forth in claim 13 wherein the medial line defines a larger curve in the longitudinal direction

15. A surgical plate system as set forth in claim 14 wherein the larger curve forms a portion of a fishtail shaped curve

16. A surgical plate system as set forth in claim 15 wherein the waist of the linking section of the first arm and of the second arm is configured to bend relative to the trunk section in response to a force applied before or during surgery without deforming the screw hole.

17. A surgical plate system as set forth in claim 16 wherein the trunk has a through hole.

18. A surgical plate system as set forth in claim 17 wherein the trunk has at least two through holes and a waist area between the through holes which encourages bending of the waist area in response to a force applied before or during surgery.

19. A surgical plate system as set forth in claim 18 wherein the trunk has an obround slot.

20. A surgical plate system as set forth in claim 19 further including at least one screw having a threaded shaft and a head wherein at least one screw hole and the screw head have a mating interface such that the screw can engage the screw hole so as to allow a plurality of angular orientations of the screw axis

21. A surgical plate system as set forth in claim 13 further including at least one screw having a threaded shaft and a head wherein at least one screw hole and the screw head have a mating interface such that the screw can engage the screw hole at a locked angular orientation of the screw axis.

22. A surgical plate system as set forth in claim 21 wherein the screw hole include internal threads and the screw head includes corresponding external threads which mate to fix the orientation of the screw in the screw hole.

23. A surgical plate system as set forth in claim 22 further including a drill guide and the screw hole includes guide keyways which orient the angle of the drill guide relative to the plate.

24. A surgical plate system as set forth in claim 13 wherein the plate is capable of being used on a clavicle.

25. A surgical plate system as set forth in claim 24 wherein the plate is capable of being used on an anterior or inferior aspect of a clavicle.

26. A method of enabling a surgery on the clavicle comprising providing a surgical tray including at least one screw and a pre-contoured plate which is has an elongate central trunk which has a medial line and either one pair or not more than two pairs of arms of a first arm and of a second arm that extend from the central trunk, and the first arm and the second arm spiraling about the medial line toward each other,

the first arm having an ear with at least one screw hole defining a first screw axis perpendicular to a tangent to the top surface of the first ear, the first ear being attached to the trunk by a linking section having a waist, a first angle and a first length being defined by a line from the center of the first arm screw hole to the intersection of the medial line of the trunk,

the second arm having a second ear with at least one second screw hole defining a second screw axis perpendicular to a tangent to the top surface of the second ear, the second ear being attached to the trunk by a linking section having a waist, a second angle and a second length being defined by a line from

the center of the second arm screw hole to the intersection of the medial line of the trunk.

the first angle and the first length being different from the second angle and the second length whereby the first screw axis and the second screw axis converge toward the inferior side of the plate but do not intersect, and

the tray further including a plate bender which will bend the linking section of the first arm and the second arm without deforming the screw hole of the arm and a drill guide.

27. A method of enabling a surgery as set forth in claim 26 wherein the first screw hole and the second screw hole include internal threads.

28. A method of enabling a surgery as set forth in claim 27 wherein the waist of the linking section of the first arm and of the second arm is configured to bend relative to the trunk section in response to a force applied before or during surgery without deforming the screw hole.

29. A method of enabling surgery as set forth in claim 26 wherein the tray has a version of a plate which has a single set of arms to form a Y-shaped profile and which has a contour that curves longitudinal in one direction and than in the other in a portion.

30. A method of enabling surgery as set forth in claim 26 wherein the tray has a version of a plate which has two sets of arms and which forms a segment of a cylinder or of a torroid.

31. A method of enabling surgery as set forth in claim 26 wherein the tray has a version of the plate which has a first terminal end with a single pair of arms with only one screw hole per arm and which defines a radius on the bone facing surface and second terminal end with a single pair of arms each having two

screw holes and which defines a second radius on the bone facing surface, which is larger than the radius of the first terminal end.

32. A method of enabling surgery as set forth in claim 26 which includes a first version of the plate which has a single set of arms to form a Y-shaped profile and which has a contour that curves longitudinal in one direction and than in the other in a portion; a second version of the plate which has two sets of arms and which forms a segment of a cylinder or of a torroid; and a third version of a plate which has a first terminal end with a single pair of arms with only one screw hole per arm and which defines a radius on the bone facing surface and second terminal end with a single pair of arms each having two screw holes and which defines a second radius on the bone facing surface, which is larger than the radius of the first terminal end.

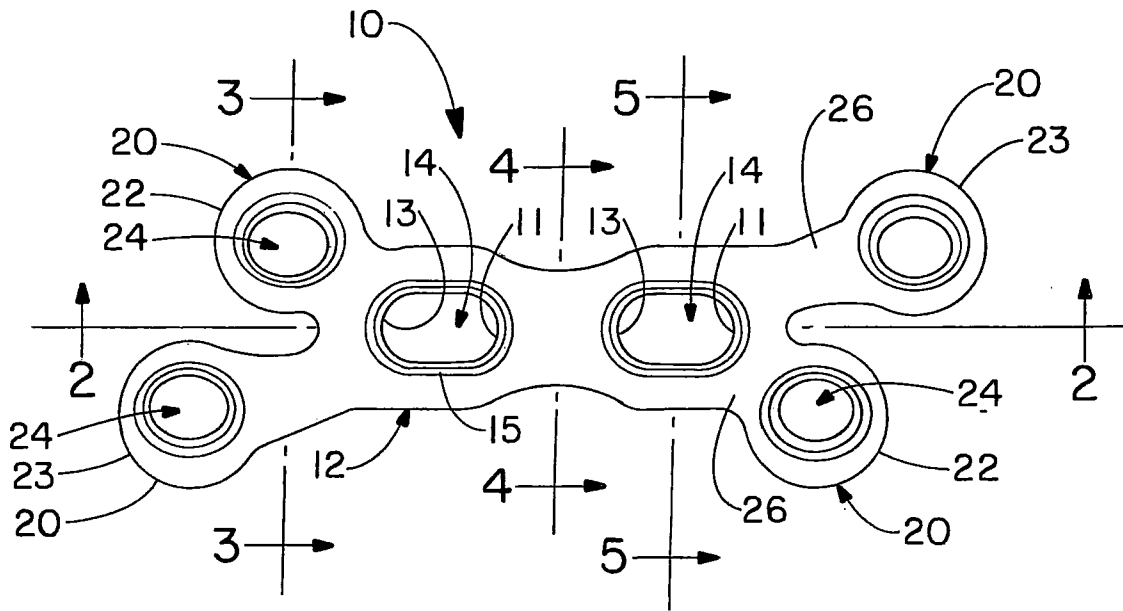

FIG. -1

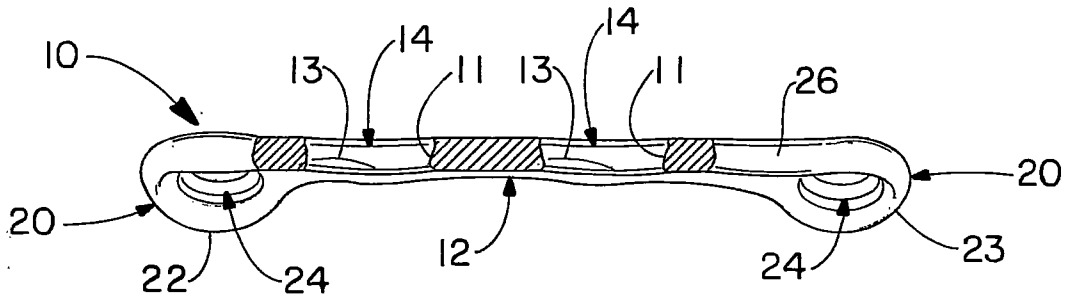

FIG. -2

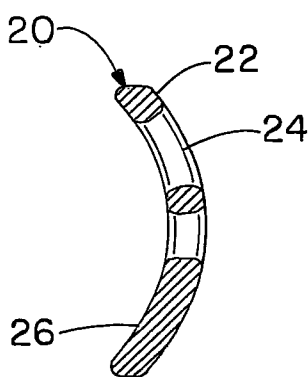

FIG. -3

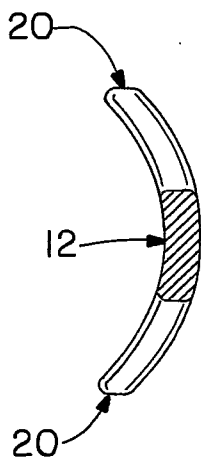

FIG. -4

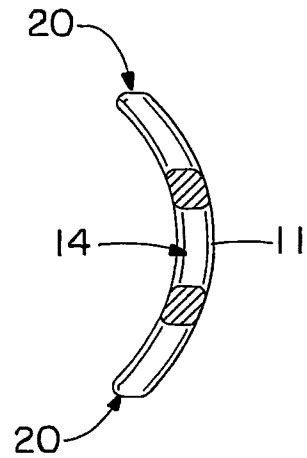

FIG. -5

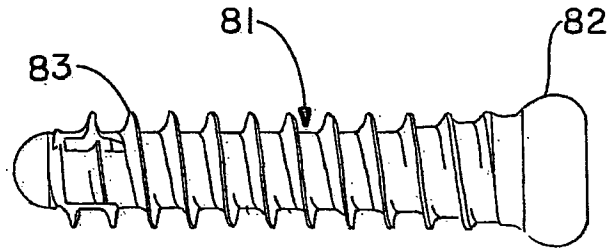

FIG. -6

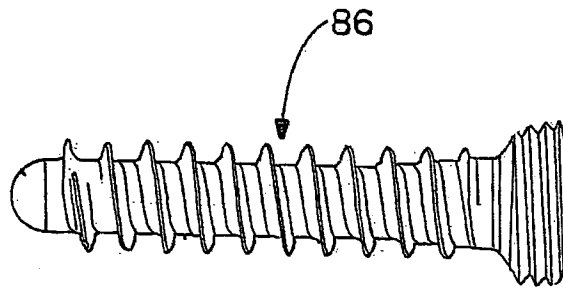

FIG. -7

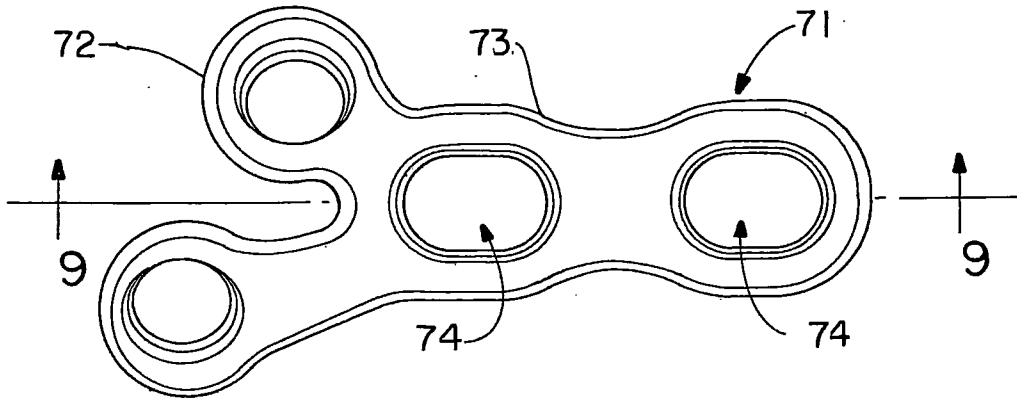

FIG. -8

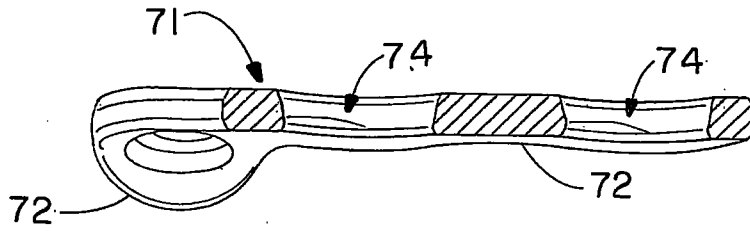

FIG. -9

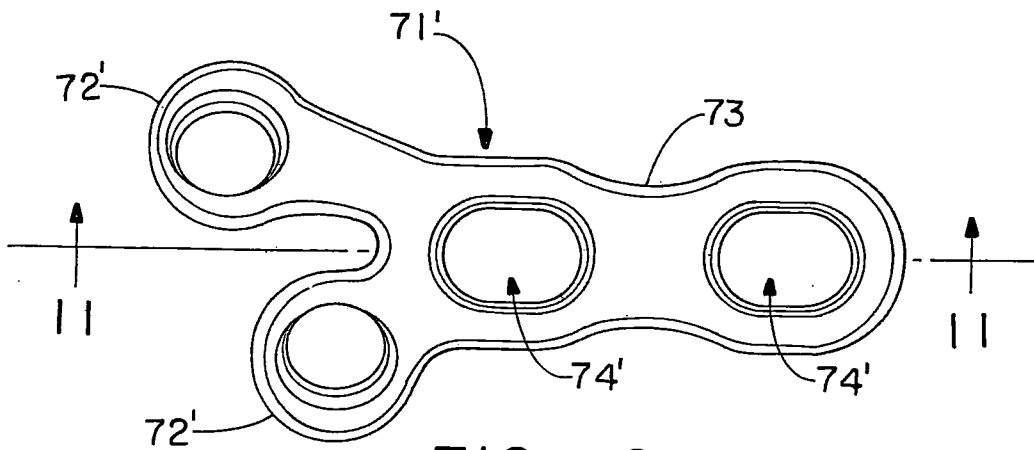

FIG. -10

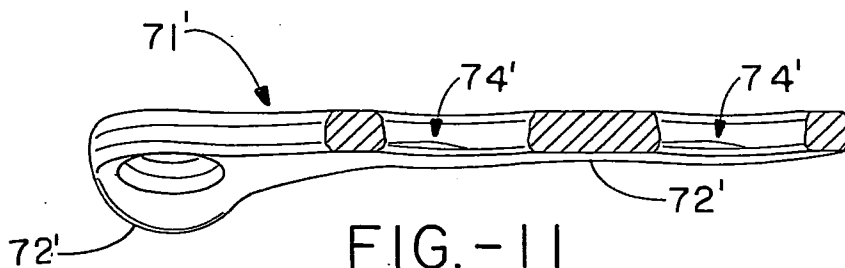

FIG. -11

4/10

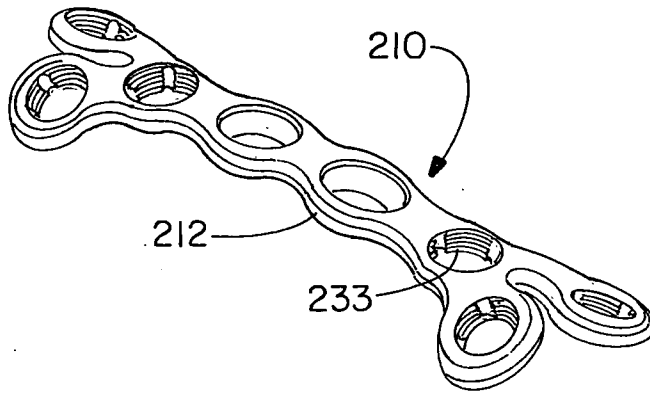

FIG. -12

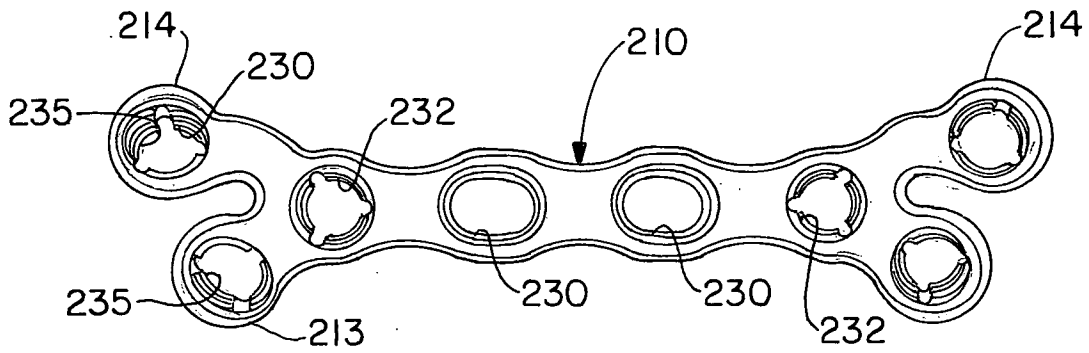

FIG. -13

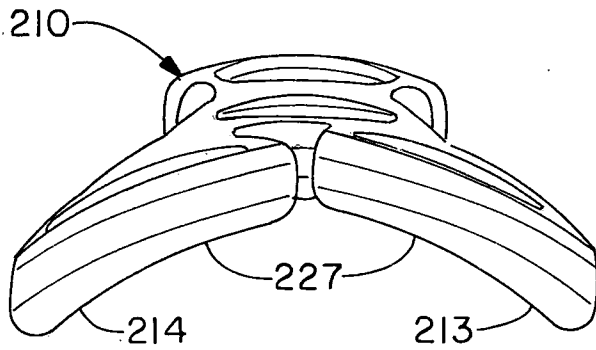

FIG. -14

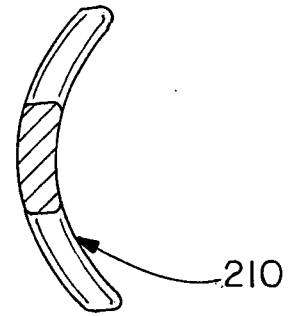

FIG. -16

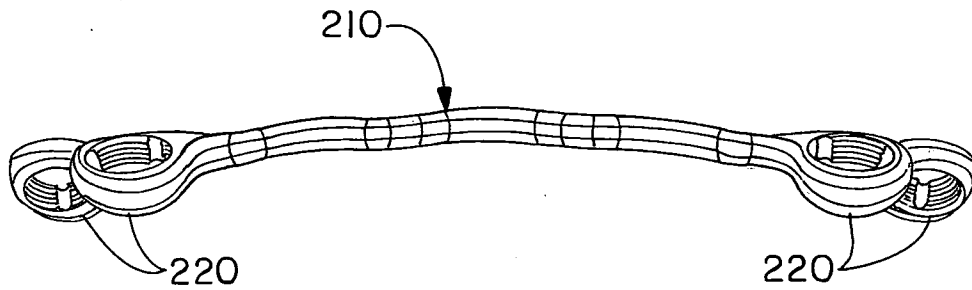

FIG. -15

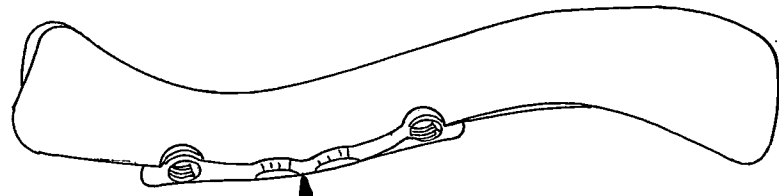

FIG.-17

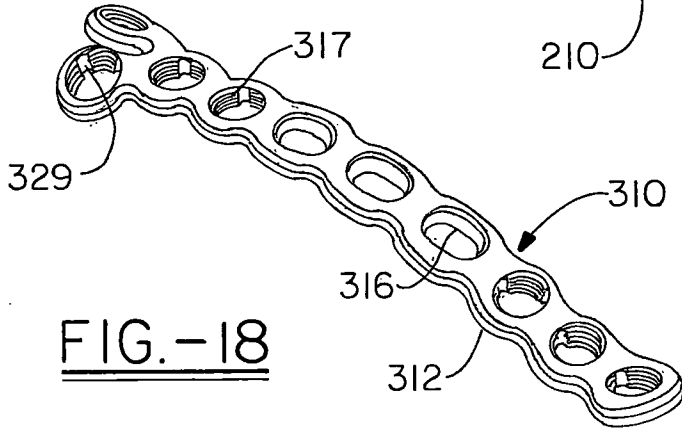

FIG.-18

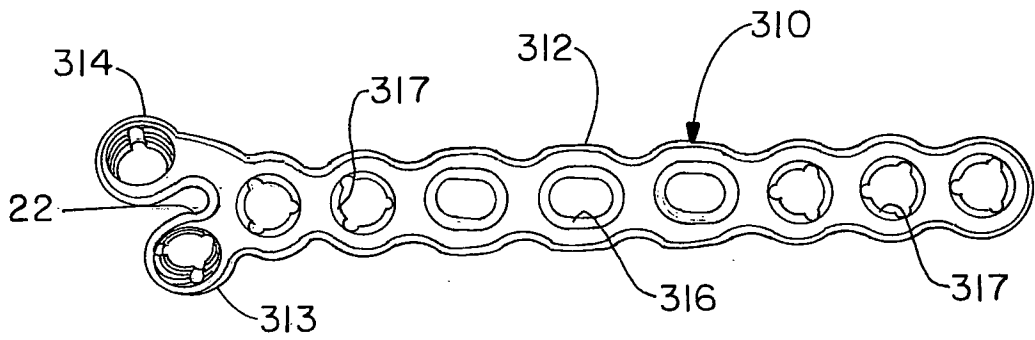

FIG.-19

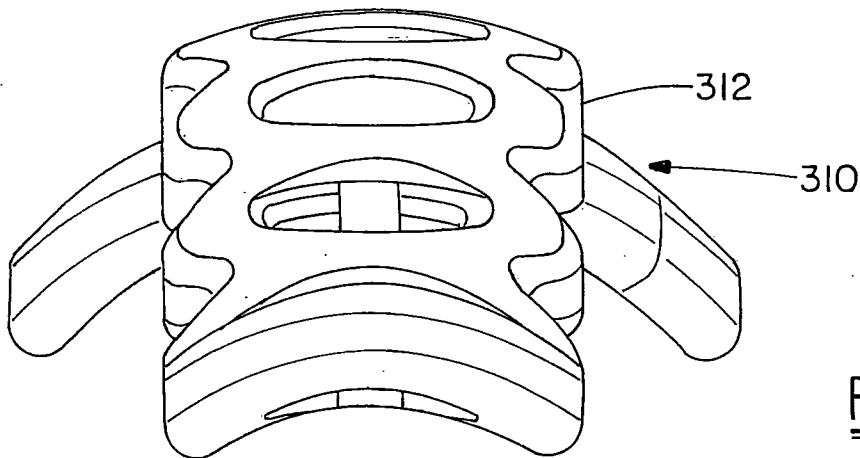

FIG.-20

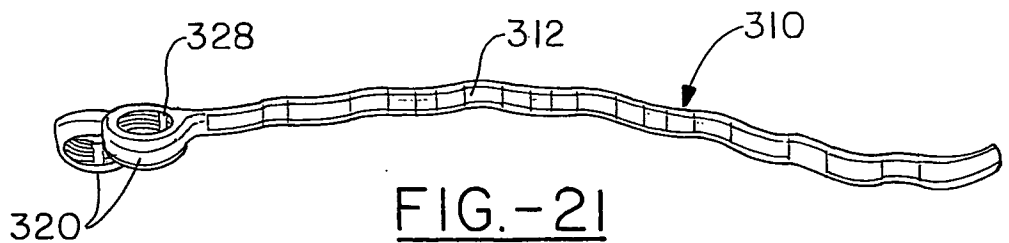

FIG.-21

FIG.-22

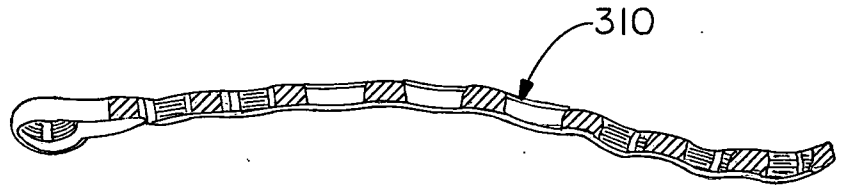

FIG.-23

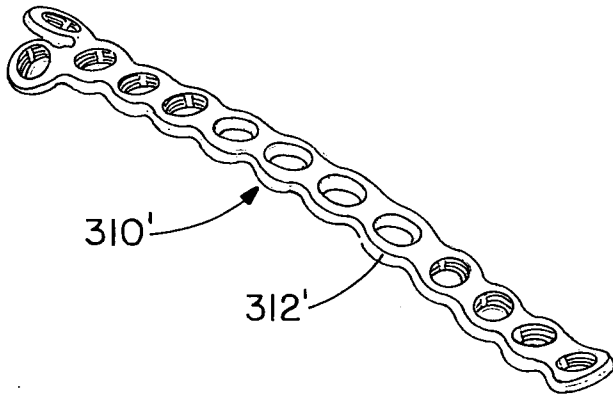
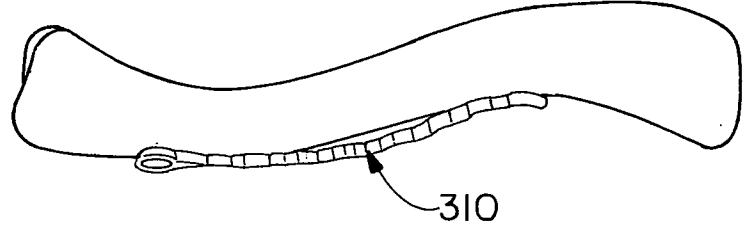

FIG.-24

FIG.-25

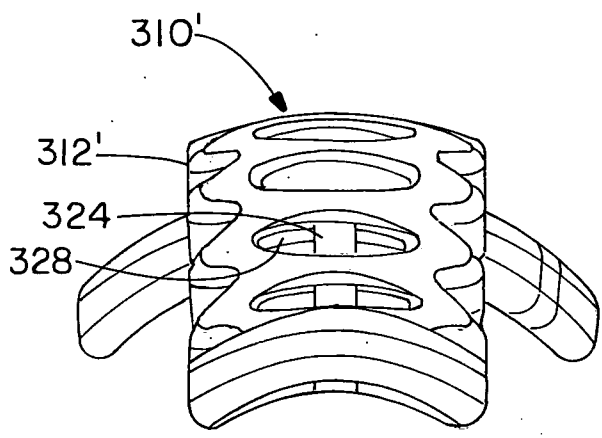
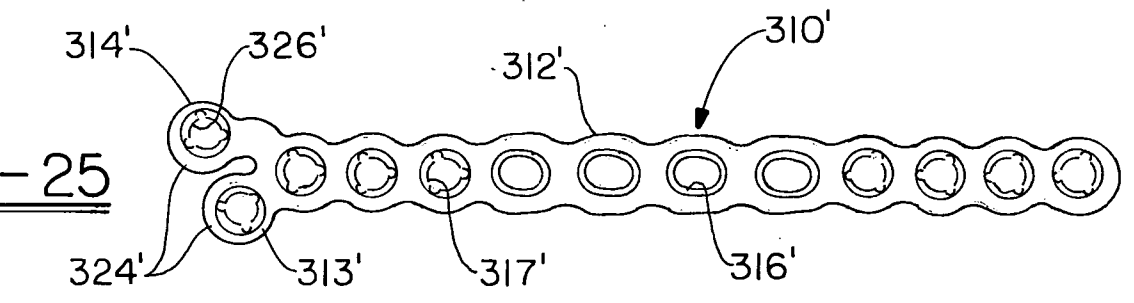

FIG.-26

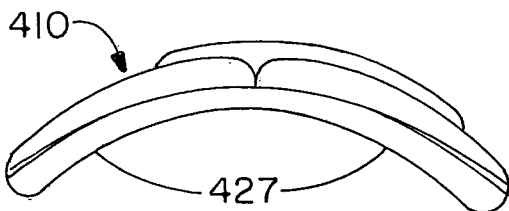
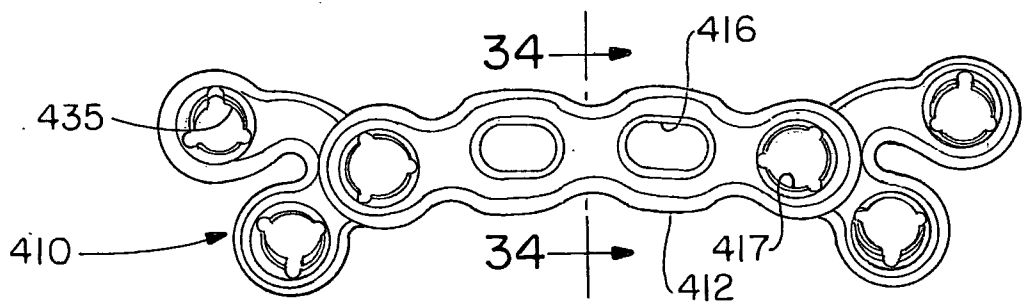
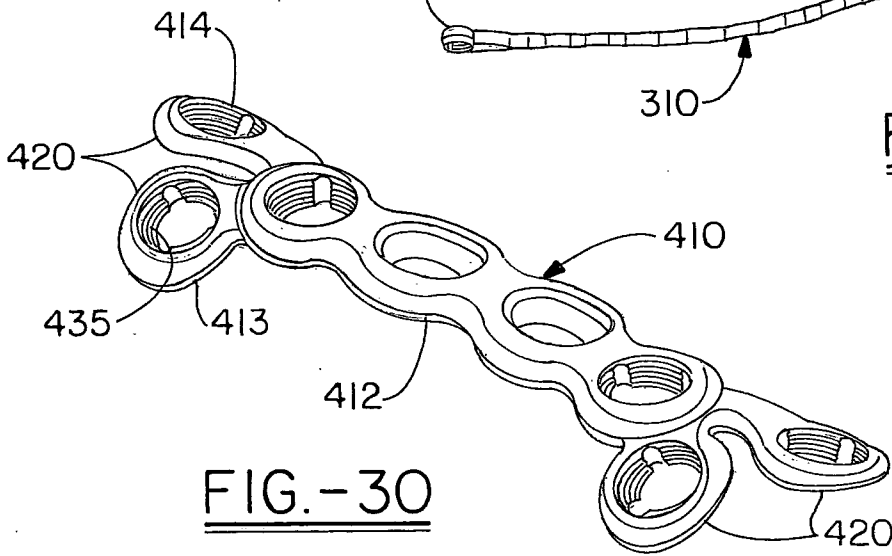
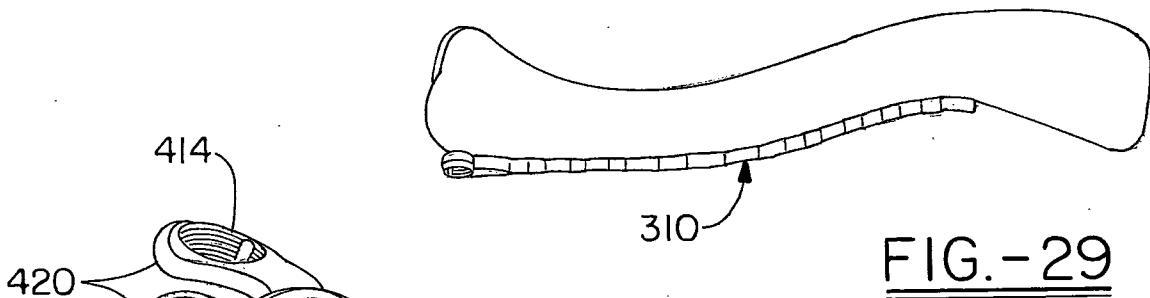
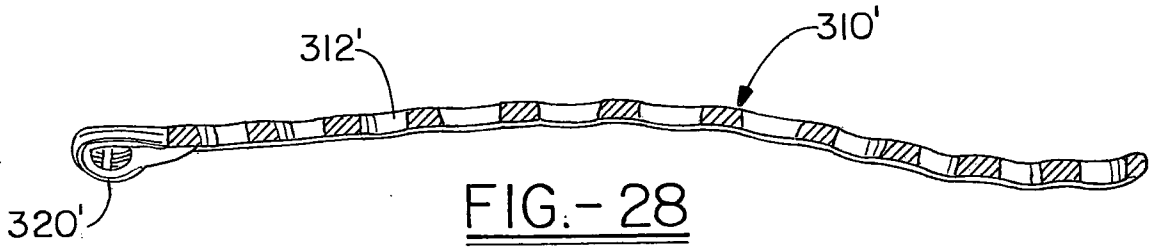
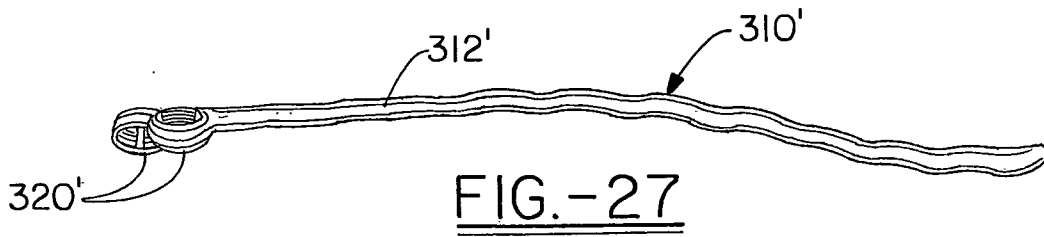

FIG. -32

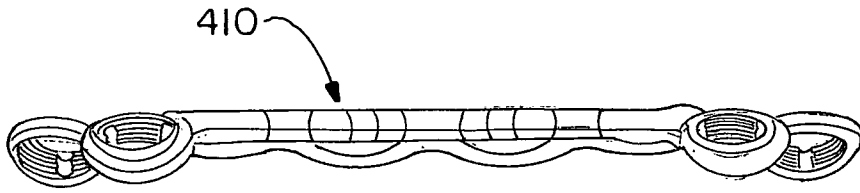

FIG. -33

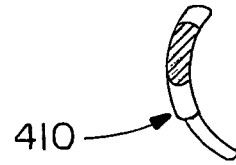

FIG. -34

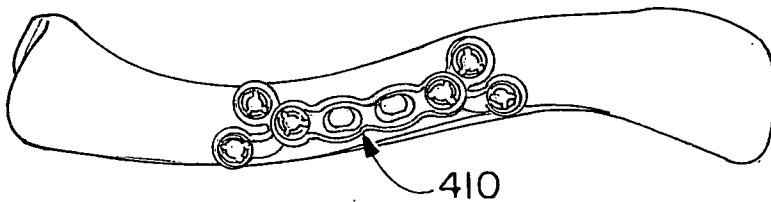

FIG. -35

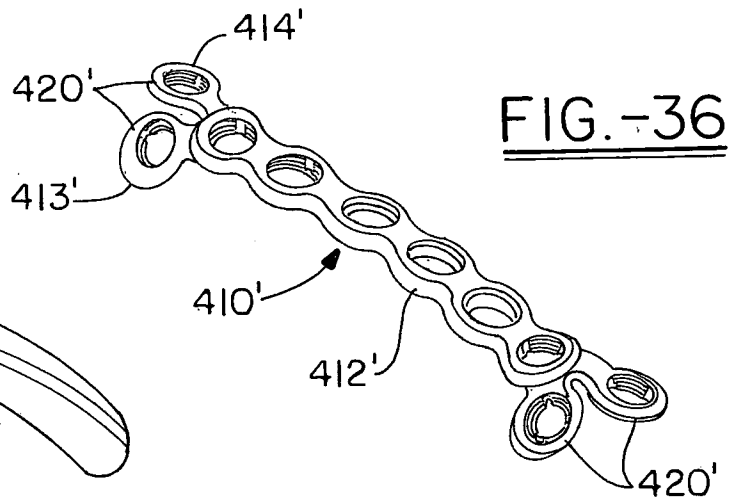

FIG. -36

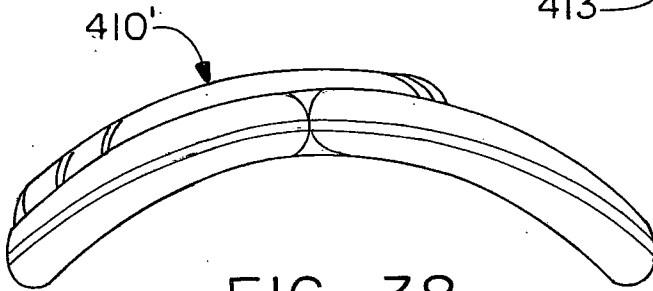

FIG. -38

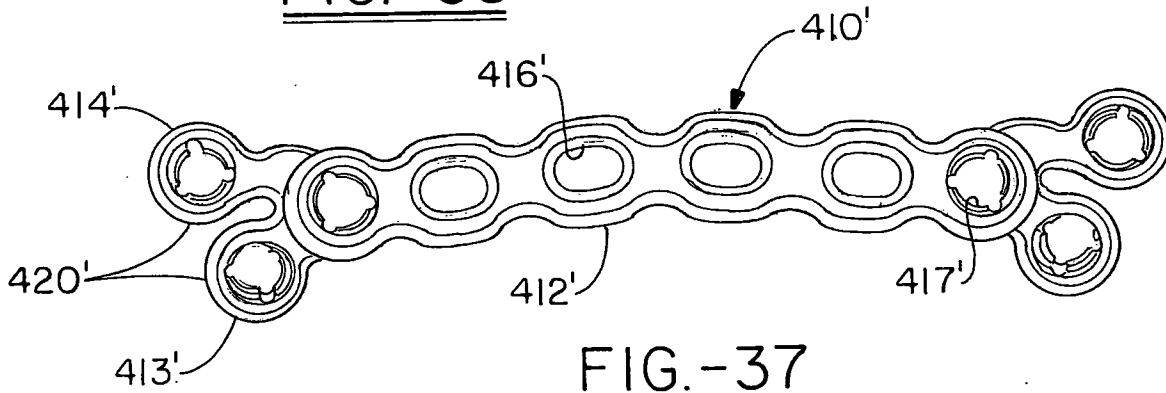

FIG. -37

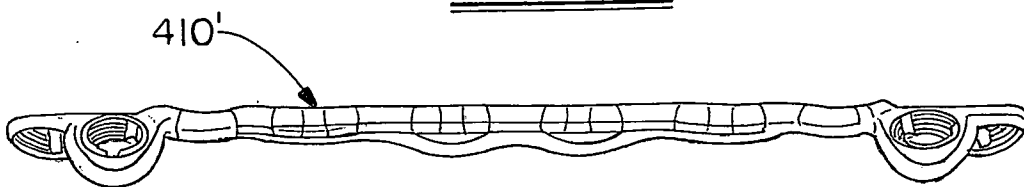

FIG. -39

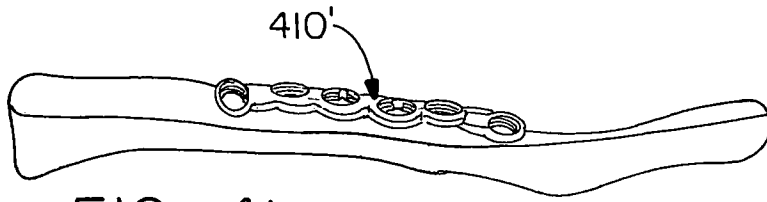

FIG. -41

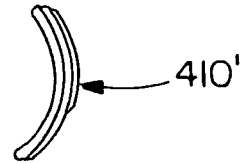

FIG. -40

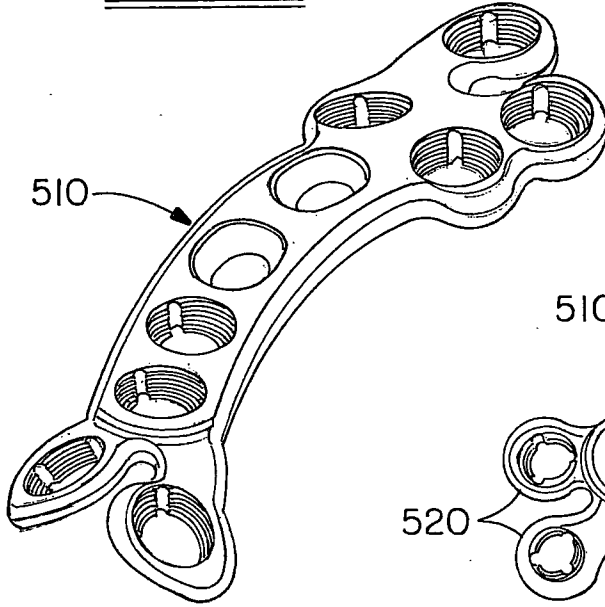

FIG. -42

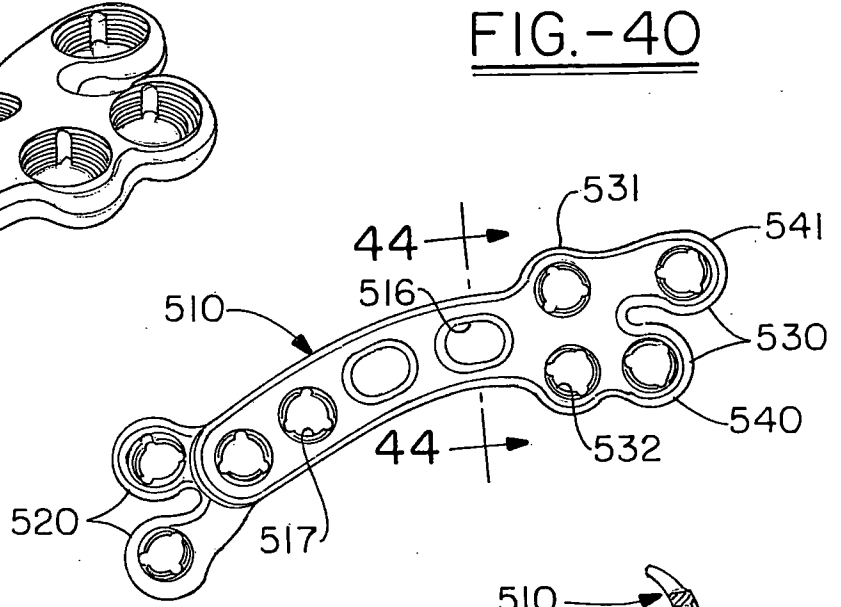

FIG. -43

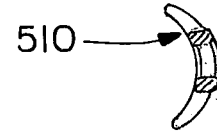

FIG. -44

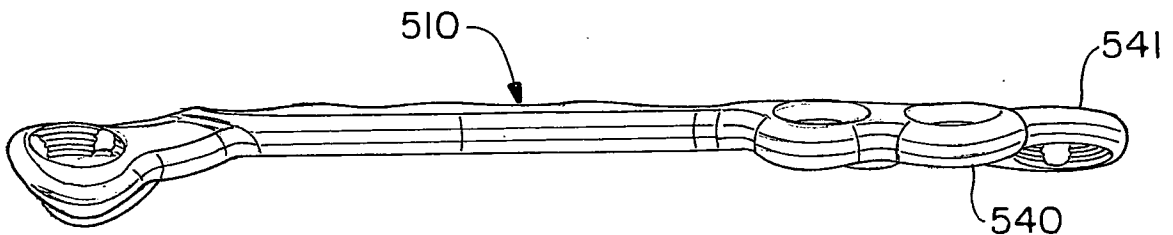

FIG. -45

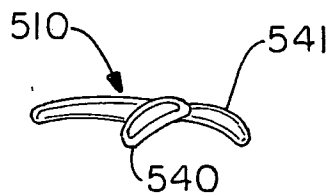

FIG. -46

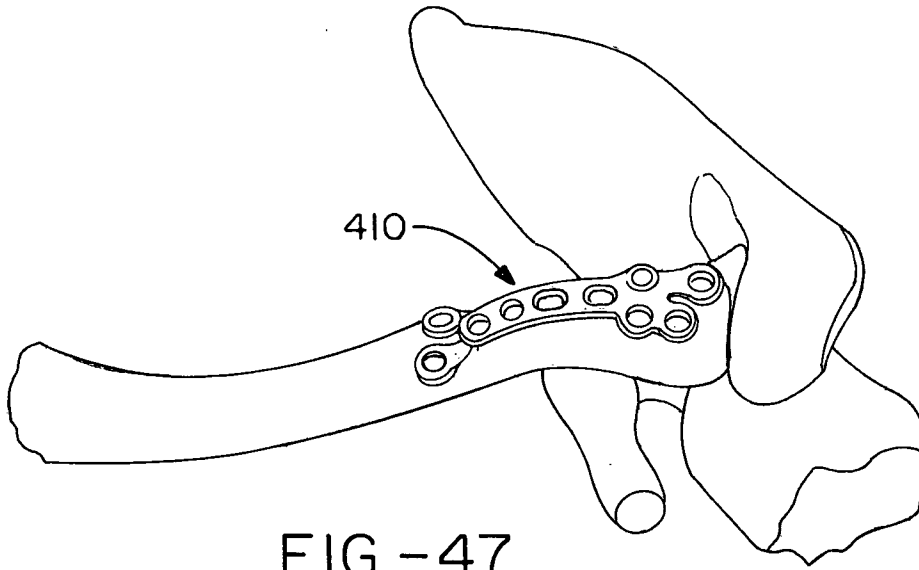

FIG.-47

INTERNATIONAL SEARCH REPORT

International application No.

PCT/US 10/00427

A. CLASSIFICATION OF SUBJECT MATTER IPC(8) - A61B 17/80 (2010.01) USPC - 606/280 According to International Patent Classification (IPC) or to both national classification and IPC		
B. FIELDS SEARCHED Minimum documentation searched (classification system followed by classification symbols) IPC8 : A61B 17/80 (2010.01) USPC : 606/280 Documentation searched other than minimum documentation to the extent that such documents are included in the fields searched IPC8 : A61B 17/56, A61B 17/68, A61B 17/88, A61B 17/90 (2010.01) USPC : 606/1, 606/53, 606/60, 606/281, 606/283, 606/96, 606/286, 606/289, 606/291, 606/902, 606/905, 606/906, 606/915 Electronic data base consulted during the international search (name of data base and, where practicable, search terms used) PubWEST (PGPB,USPT,EPAB,JPAB), Google Scholar concentric, constant, contour, bend, bent, curv\$, radius, cylind\$, y shap\$, clavicle, clavicular, collar bone, plate, fixat\$, screw, axis, interfer\$, conflict, offset, stagger, diverg\$, oblique\$, arm, trunk, cortical		
C. DOCUMENTS CONSIDERED TO BE RELEVANT		
Category*	Citation of document, with indication, where appropriate, of the relevant passages	Relevant to claim No.
Y	US 2008/0300637 A1 (AUSTIN et al) 4 December 2008 (04.12.2008) see especially para [0103], [0104], [0106], [0107], [0111], [0116], [0117], [0120], [0124], [0125], [0129], [0131], [0138], [0145], [0146], [0190], [0195], figs 3, 5, 12-15, 23, 29, 48, 54	1-32
Y	US 2006/0241608 A1 (MYERSON et al) 26 October 2006 (26.10.2006) see especially para [0024]-[0027], figs 1-4	1-32
Y	US 2005/0216008 A1 (ZWIRNMANN et al) 29 September 2005 (29.09.2005) see especially para [0078], [0081], [0082], figs 9, 12, 13	2-5, 29, 30, 32
Y	WO 2008/064211 A1 (CHREENE et al) 29 May 2008 (29.05.2008) see especially para [0054], [0061]	12, 23
Y	US 2006/0161158 A1 (ORBAY et al) 20 July 2006 (20.07.2006) see especially para [0021], [0055]	26-32
<input type="checkbox"/> Further documents are listed in the continuation of Box C. <input type="checkbox"/>		
* Special categories of cited documents: "A" document defining the general state of the art which is not considered to be of particular relevance "E" earlier application or patent but published on or after the international filing date "L" document which may throw doubts on priority claim(s) or which is cited to establish the publication date of another citation or other special reason (as specified) "O" document referring to an oral disclosure, use, exhibition or other means "P" document published prior to the international filing date but later than the priority date claimed "T" later document published after the international filing date or priority date and not in conflict with the application but cited to understand the principle or theory underlying the invention "X" document of particular relevance; the claimed invention cannot be considered novel or cannot be considered to involve an inventive step when the document is taken alone "Y" document of particular relevance; the claimed invention cannot be considered to involve an inventive step when the document is combined with one or more other such documents, such combination being obvious to a person skilled in the art "&" document member of the same patent family		
Date of the actual completion of the international search 24 March 2010 (24.03.2010)		Date of mailing of the international search report 03 MAY 2010
Name and mailing address of the ISA/US Mail Stop PCT, Attn: ISA/US, Commissioner for Patents P.O. Box 1450, Alexandria, Virginia 22313-1450 Facsimile No. 571-273-3201		Authorized officer: Lee W. Young PCT Helpdesk: 571-272-4300 PCT OSP: 571-272-7774