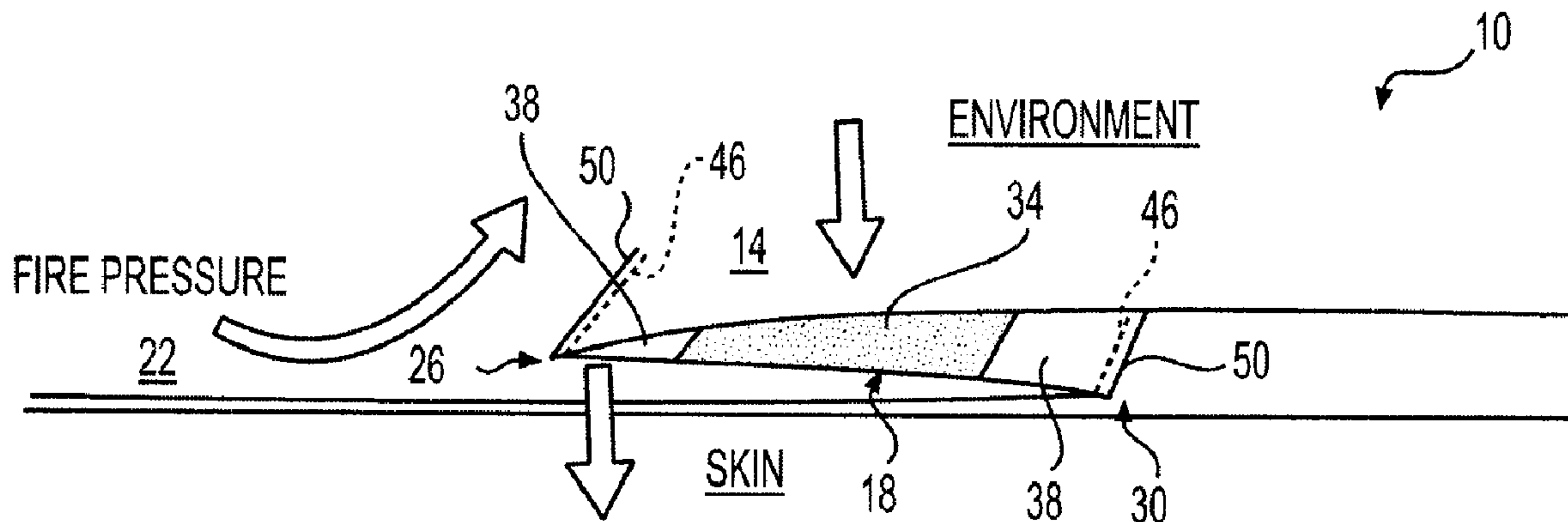




(22) Date de dépôt/Filing Date: 2013/12/04  
 (41) Mise à la disp. pub./Open to Public Insp.: 2014/06/10  
 (45) Date de délivrance/Issue Date: 2015/11/24  
 (30) Priorités/Priorities: 2012/12/10 (CA2798649);  
 2013/08/08 (CA2823035)

(51) Cl.Int./Int.Cl. *A41D 27/28* (2006.01),  
*A41D 1/00* (2006.01), *A41D 3/02* (2006.01),  
*A62B 17/00* (2006.01)  
 (72) Inventeur/Inventor:  
 AUDET, JEAN-PIERRE, CA  
 (73) Propriétaire/Owner:  
 CODET INC., CA  
 (74) Agent: AUDET, MATHIEU

(54) Titre : TRAPPE DE VENTILATION DE BLOCAGE DE FLAMMES ET VETEMENT DE PROTECTION  
 (54) Title: FLAME BLOCKING VENTING TRAP AND PROTECTION GARMENT THEREOF



(57) **Abrégé/Abstract:**

The application relates to a flame blocking venting trap (FBVT) adapted to vent a garment, the FBVT comprising a proximal layer; a central venting layer superposed to the proximal layer; and a distal layer superposed to the central venting layer. The proximal layer is forming a first fold with the central venting layer and the central venting layer is forming a second fold with the distal layer to act as a flow restricting apparatus configured to prevent air and flames to get throught the FBVT from the outside of the garment and allow air to get through the FBVT from the inside of the garment. A garment including one or many FBVT is encompassed by the present application.

MTC-157-004-CA1

1  
2  
3  
4  
5  
6  
7  
8  
9  
10  
11**ABSTRACT**

The application relates to a flame blocking venting trap (FBVT) adapted to vent a garment, the FBVT comprising a proximal layer; a central venting layer superposed to the proximal layer; and a distal layer superposed to the central venting layer. The proximal layer is forming a first fold with the central venting layer and the central venting layer is forming a second fold with the distal layer to act as a flow restricting apparatus configured to prevent air and flames to get through the FBVT from the outside of the garment and allow air to get through the FBVT from the inside of the garment. A garment including one or many FBVT is encompassed by the present application.

MTC-157-004-CA1

1 **FLAME BLOCKING VENTING TRAP AND PROTECTION GARMENT THEREOF**

2

3

**BACKGROUND OF THE INVENTION**4 **1. Field of the Invention**

5 **[01]** This invention generally relates to a flame blocking venting trap adapted  
6 to be installed on, or be incorporated in, a safety garment. The present invention  
7 more specifically relates to a flame blocking venting trap adapted to allow air venting  
8 while preventing flames to get through the suit and reach the skin of a wearer of the  
9 garment.

10

11 **2. Description of the Related Art**

12 **[02]** Protection garments have been used for many purposes against many  
13 environmental factors like oil, gas, grease dirt, solvent, chemicals, water and  
14 biohazard, among others. Workers performing tasks associated with significant  
15 fire hazards can also use them. For instance, they can be used in the gas and oil  
16 industries where the likelihood of fire blast, or flash fire, is present.

17

18 **[03]** Protection garments can come in a variety of configurations. Shirts and  
19 pants can be used individually or collectively to protect a worker in accordance with  
20 the specifics of the tasks to accomplish. The protection garment can also be a one-  
21 piece article of clothing commonly called a *coverall*. A coverall is usually a loose  
22 fitting garment comprising a trouser-like portion and top portion, with or without  
23 sleeves, that is usually worn over casual clothing.

24 **[04]** The material used in a protection garment is often rugged or intrinsically  
25 prevents air to pass therethrough because of its technical and protective properties.  
26 Venting in a protection garment has therefore a significant importance to prevent  
27 overheating of the wearer. Flexibility and comfort can also be challenging given the  
28 nature and the stiffness of the material.

**MTC-157-004-CA1**

1 [05] It is therefore desirable to provide a flame blocking ventilation trap on a  
2 protection garment that allows ventilation therethrough while preventing flames to  
3 get through the ventilation trap.

4 [06] It is desirable to provide an improved protection garment over the existing  
5 art that allows ventilation while preventing flames to get therethrough.

6 [07] It is desirable to provide an improved ventilation trap over the existing art  
7 that can be easily assembled to the fabric of a safety garment and allows ventilation  
8 while preventing flames to get therethrough.

9 [08] It is desirable to provide an improved ventilation trap over the existing art  
10 that has a reduced thickness and is easily assembled to the fabric without causing  
11 significant local rigidity to the safety garment.

12 [09] It is desirable to provide an improved ventilation trap over the existing art  
13 that uses, in part, the same fabric as the material used in the safety garment and  
14 allows ventilation while preventing flames to get therethrough.

15 [10] It is also desirable to provide an improved protection garment over the  
16 existing art that improves flexibility of the garment while allowing air circulation and  
17 prevents flames to pass through the garment and contact the skin of the wearer.

18 [11] Other deficiencies will become apparent to one skilled in the art to which  
19 the invention pertains in view of the following summary and detailed description with  
20 its appended figures.

21

22

**SUMMARY OF THE INVENTION**

23 [12] One aspect of the present invention is to alleviate one or more of the  
24 shortcomings of the background art by addressing one or more of the existing needs  
25 in the art.

26 [13] The following presents a simplified summary of the invention in order to  
27 provide a basic understanding of some aspects of the invention. This summary is not  
28 an extensive overview of the invention. It is not intended to identify key/critical  
29 elements of the invention or to delineate the scope of the invention. Its sole purpose

**MTC-157-004-CA1**

1 is to present some concepts of the invention in a simplified form as a prelude to the  
2 more detailed description that is presented later.

3 **[14]** The invention is generally described as a flame blocking ventilation trap  
4 and a garment including the flame blocking ventilation trap therein. For facilitating  
5 the reading of the application, *flame blocking ventilation trap* is going to be referred  
6 to below as “FBVT”.

7 **[15]** Aspects of our work, in accordance with at least one embodiment, provide  
8 a FBVT that allows ventilation while preventing flames to get therethrough.

9 **[16]** Aspects of our work, in accordance with at least one embodiment, provide  
10 a FBVT in a safety garment that allows ventilation of the garment while preventing  
11 flames to get therethrough.

12 **[17]** Aspects of our work, in accordance with at least one embodiment, provide  
13 a FBVT that can be easily assembled to the fabric of a safety garment and allows  
14 ventilation while preventing flames to get therethrough.

15 **[18]** Aspects of our work, in accordance with at least one embodiment, provide  
16 a FBVT that has a reduced thickness and is easily assembled to the garment without  
17 causing significant local increased rigidity of the safety garment.

18 **[19]** Aspects of our work, in accordance with at least one embodiment, provide  
19 a FBVT that uses, in part, the same fabric as the material used for the safety  
20 garment and allows ventilation while preventing flames to get therethrough.

21 **[20]** Aspects of our work, in accordance with at least one embodiment, provide  
22 a FBVT adapted to be restricted, or closed, when an external pressure is applied  
23 thereon and to open when the external pressure is removed.

24 **[21]** Aspects of our work, in accordance with at least one embodiment, provide  
25 a FBVT having a “Z” shape adapted to route a flame blast from circulating through  
26 an opening in the FBVT.

27 **[22]** Aspects of our work, in accordance with at least one embodiment, provide  
28 a FBVT having a double-fold “Z” shaped layout including a distal layer of material, a  
29 central layer of air permeable material (e.g. mesh) and a proximal layer of material  
30 adapted to route a flame blast from circulating through an opening in the FBVT.

**MTC-157-004-CA1**

- 1 **[23]** Aspects of our work, in accordance with at least one embodiment, provide  
2 a FBVT configured to allow air ventilation of the garment while blocking flames to get  
3 through the garment.
- 4 **[24]** Aspects of our work, in accordance with at least one embodiment, provide  
5 a FBVT configured to close an opening thereof when a flow of air reaches the FBVT  
6 from the exterior to prevent air to get through the garment through the FBVT.
- 7 **[25]** Aspects of our work, in accordance with at least one embodiment, provide  
8 a garment comprising a FBVT therein.
- 9 **[26]** Aspects of our work, in accordance with at least one embodiment, provide  
10 a FBVT including a mesh portion extending with a pair of non-mesh portions  
11 extending on respective sides of the mesh portion.
- 12 **[27]** Aspects of our work, in accordance with at least one embodiment, provide  
13 a FBVT including a mesh portion extending with a non-mesh portions extending on a  
14 side of the mesh portion.
- 15 **[28]** Aspects of our work, in accordance with at least one embodiment, provide  
16 a FBVT including a mesh portion extending with a non-mesh portions extending on a  
17 side of the mesh portion. Each non-mesh portion interconnecting a fabric portion via  
18 a fold.
- 19 **[29]** Aspects of our work, in accordance with at least one embodiment, provide  
20 a FBVT including a first layer of fabric superposed over a layer of mesh portion, that  
21 is disposed over a second layer of fabric.
- 22 **[30]** Aspects of our work, in accordance with at least one embodiment, provide  
23 a FBVT including, sequentially, a first layer of fabric, mesh portion, and a second  
24 layer of fabric.
- 25 **[31]** Aspects of our work, in accordance with at least one embodiment, provide  
26 a FBVT including a mesh portion comprising a central mesh extended by at least  
27 one non-mesh portion.
- 28 **[32]** Aspects of our work provide kit comprising a plurality of FBVTs adapted to  
29 be secured or sewed to a garment.

**MTC-157-004-CA1**

1 **[33]** Aspects of our work provide a FBVT that complies with safety requirement  
2 NFPA 2112 and ASTM international requirement F1505.

3 **[34]** Aspects of our work provide a flame blocking venting trap (FBVT) adapted  
4 to vent a garment, the FBVT comprising a proximal layer; a central venting layer  
5 superposed to the proximal layer; and a distal layer superposed to the central  
6 venting layer.

7 **[35]** Aspects of our work provide a garment comprising a flame blocking  
8 venting trap (FBVT) adapted to vent the garment, the flame blocking coverall  
9 comprising a proximal layer; a central venting layer superposed to the proximal  
10 layer; and a distal layer superposed to the central venting layer.

11 **[36]** Each of the embodiments of the present invention has at least one of the  
12 above-mentioned objects and/or aspects, but does not necessarily have all of them.  
13 It should be understood that some aspects of the present invention that have  
14 resulted from attempting to attain the above-mentioned objects may not satisfy these  
15 objects and/or may satisfy other objects not specifically recited herein.

16 **[37]** Additional and/or alternative features, aspects, and advantages of  
17 embodiments of the present invention will become apparent from the following  
18 description, the accompanying drawings, and the appended claims.

19

20

#### **BRIEF DESCRIPTION OF THE DRAWINGS**

21 **[38]** Figure 1 is a schematic illustration of an FBVT in accordance with an  
22 embodiment of the invention;

23 **[39]** Figure 2 is a schematic illustration of an FBVT in accordance with an  
24 embodiment of the invention with air passing therethrough from the exterior of the  
25 garment;

26 **[40]** Figure 3 is a schematic illustration of an FBVT in accordance with an  
27 embodiment of the invention with air passing therethrough from the interior of the  
28 garment;

## MTC-157-004-CA1

- 1 [41] Figure 4 is a schematic illustration of an FBVT in accordance with an  
2 embodiment of the invention with flame pattern thereof;
- 3 [42] Figure 5 is a schematic illustration of an FBVT in accordance with an  
4 embodiment of the invention with flame pattern thereof;
- 5 [43] Figure 6 is a schematic illustration of an FBVT in accordance with an  
6 embodiment of the invention with flame pattern thereof;
- 7 [44] Figure 7 is a schematic illustration of an FBVT in accordance with an  
8 embodiment of the invention with air flow pattern thereof;
- 9 [45] Figure 8 is a schematic illustration of an FBVT in accordance with an  
10 embodiment of the invention with air flow pattern thereof;
- 11 [46] Figure 9 is a schematic illustration of an exemplary mesh portion in  
12 accordance with an embodiment of the invention;
- 13 [47] Figure 10 is a schematic illustration of a front view of a coverall protection  
14 garment in accordance with an embodiment of the invention;
- 15 [48] Figure 11 is a schematic illustration of a rear view of a coverall protection  
16 garment in accordance with an embodiment of the invention;
- 17 [49] Figure 12 is a schematic illustration of a right-rear view of a protection  
18 garment in accordance with an embodiment of the invention;
- 19 [50] Figure 13 is a schematic illustration of a right-rear view of a protection  
20 garment in accordance with an embodiment of the invention;
- 21 [51] Figure 14 is a schematic illustration of a right-rear view of a protection  
22 garment in accordance with an embodiment of the invention;
- 23 [52] Figure 15 is a schematic illustration of a right-rear view of a protection  
24 garment in accordance with an embodiment of the invention;
- 25 [53] Figure 16 is a schematic illustration of a partial section view of a rear  
26 portion of a protection garment in accordance with an embodiment of the invention;
- 27 [54] Figure 17 is a schematic illustration of a rear portion of a protection  
28 garment in accordance with an embodiment of the invention with an air flow pattern  
29 thereof; and

1 [55] Figure 18 is an illustration of a commercial embodiment of the present  
2 invention.

3

#### 4 DESCRIPTION OF EMBODIMENT(S) OF THE INVENTION

5 [56] Our work is now described with reference to the figures. In the following  
6 description, for purposes of explanation, numerous specific details are set forth in  
7 order to provide a thorough understanding of the present invention by way of  
8 embodiment(s). It may be evident, however, that the present invention may be  
9 practiced without these specific details.

10 [57] A schematic FBVT 10 is illustrated in Figure 1 in accordance with an  
11 embodiment of the invention. The FBVT 10 comprises a distal fabric layer 14, a  
12 central venting layer 18 and a proximal fabric layer 22. The distal fabric layer 14 is  
13 interconnected with the central venting layer 18 with an intervening external curve, or  
14 fold 26, and the central venting layer 18 is interconnecting the proximal fabric layer  
15 22 with an intervening internal curve, or fold 30. The central venting layer 18 further  
16 includes a mesh portion 34 and extension fabric portions 38. The central venting  
17 layer 18 can be made of a single part including a portion adapted to allow an air  
18 passage thereof and can alternatively be made of an assembly of different types of  
19 fabrics and mesh. Figure 1 illustrates an assembled central venting layer 18 where  
20 different materials 34, 38 are secured with stitches 42 or any other means adapted to  
21 secure materials together with sufficient strength (e.g. Velcro™, glue, ...).

22 A typical flow of air through the FBVT 10 is illustrated in Figure 2. The flow of air is  
23 channeled from the environment between the central venting layer 18 and the  
24 proximal fabric layer 22 to pass through the mesh portion 22 and continue between  
25 the central venting layer 18 and the distal fabric layer 14 to reach the interior side of  
26 the FBVT 10 to vent the wearer of the safety garment. The proximal layer 22, central  
27 layer 18 and distal layer 14 are configured to route air from outside the FBVT,  
28 through the proximal side of the central layer 18, inside the FBVT, in a direction  
29 toward the proximal side of the distal layer 14. Figure 3 illustrates the opposite body  
30

31

1 heat transfer from the interior side of the FBVT 10 to the environment under normal  
2 circumstances. One can also appreciate that the FBVT 10 has sort of a “Z” shape (or  
3 “S” shape) with well-defined folds 26, 30 thereof to produce a path of fabric adapted  
4 to channel air thereof. A flow of air from the inside of the garment tends to open the  
5 FBVT. The FBVT, in the present embodiment,

6  
7  
8  
9  
10  
11  
12  
13  
14  
15  
16  
17  
18  
19  
20  
21  
22  
23  
24  
25  
26  
27  
28  
29  
30  
31  
32

**MTC-157-004-CA1**

1 includes additional seams 46 next to the edges 50 of the FBVT 10 to form folds.  
2 Well-defined folds 36, 30 could alternatively be made by pressing or gluing, thermo-  
3 forming the material in the desired shape. Other means to form the material can  
4 become apparent to a skilled reader and remain within the scope of the present  
5 invention.

6 **[59]** The FBVT 10 acts differently when a flame blast reaches the FBVT 10  
7 from the environment. Figure 4 illustrates that the FBVT 10 protects from flames  
8 hitting the FVBT 10 from the environment by compressing the layers 14, 18, 22 of  
9 the FBVT 10 that, in turn, is going to close the FBVT 10 as illustrated in Figure 5 and  
10 thus prevent the flames to get through the FBVT 10 with the fire pressure. A flow of  
11 air from the outside of the garment 66 thus tends to close the FBVT. The FBVT 10  
12 can also reacts differently if the flame blast comes parallel with the layer 22. The  
13 extension fabric portion 38 next to the internal edge 50 prevents the flame to be  
14 directed through the mesh portion 34 and redirects the flame in the opposite  
15 direction 54. The configuration of the FBVT 10 also prevents any direct contact with  
16 the skin of a wearer as illustrated in Figure 6. One can appreciate from Figure 6 that  
17 a flame would pass through the mesh portion 34 to hit the distal fabric layer 14 or be  
18 confined in the internal fold 50 thus providing an additional safety protection should a  
19 flame reaches the mesh portion 34.

20 **[60]** Figure 7 depicts embodiment of lengths ratios of mesh portion 34 in  
21 respect with extension fabric portions 38.1, 38.2. In an embodiment, the length A of  
22 the mesh portion 34 can vary between 10 mm and 100 mm, the length B of the  
23 extension fabric portion 38.1 can vary between 0 mm and 50 mm and finally the  
24 length C of extension fabric portions 38.2 can vary between 0 mm and 50 mm.  
25 Preferably, the length A of the mesh portion 34 can vary between 25 mm and 75  
26 mm, the length B of the extension fabric portion 38.1 can vary between 0 mm and 30  
27 mm and finally the length C of extension fabric portions 38.2 can vary between 10  
28 mm and 40 mm. More preferably, the length A of the mesh portion 34 can vary  
29 between 40 mm and 60 mm, the length B of the extension fabric portion 38.1 can  
30 vary between 10 mm and 25 mm and finally the length C of extension fabric portions  
31 38.2 can preferably vary between 20 mm and 35 mm. Other lengths can also be  
32 used depending of the design of the garment and the specific venting requirement.

**MTC-157-004-CA1**

1 The lengths ratios can change depending of the size and design of the FBVT 10 and  
2 can be about (0@1)B for (2@5)A for (0@3)C, preferably about (0@1)B for (3@5)A  
3 for (1@3)C, and more preferably about (1)B for (4)A for (2)C (1B:4A:2C). Figure 9  
4 depicts an embodiment with more precise lengths to illustrate one of the preferred  
5 embodiments.

6 **[61]** Turning now to Figure 9 illustrating an exemplary mesh portion 34 in  
7 accordance with an embodiment of the invention. The mesh portion 34 is provided  
8 with a series of holes or openings 58 adapted to let air pass therethrough. The  
9 remaining portion of the mesh portion 34 is fabric material 62 adapted to provide  
10 mechanical strength to the mesh portion 34.

11 **[62]** A protection garment 66 is schematically illustrated in Figure 10 in  
12 a front view. The protection garment 66 includes an upper portion 70 and a lower  
13 portion 74 that can be used independently or collectively. An assembled upper  
14 portion 70 and lower portion 74 can be called a one-piece coverall. The illustrated  
15 protection garment 66 includes pockets 78 and a zipper 82, or a securing means, to  
16 secure the protection garment on a wearer. Figure 11 is a back view of the  
17 protection garment 66 of Figure 10. One can appreciate from Figure 11 possible  
18 venting zones 86 on the protection garment 66 where a FBVT 10 can be located.  
19 FBVT 10 can be disposed vertically and horizontally on the protection garment 66.  
20 The FBVT 10 can be located in the region of an articulation to help open the FBVT  
21 10 with the movements of a wearer. One can appreciate that restrictors 90 are  
22 located between the distal layer 14 and the proximal layer 22 to secure the three  
23 layers 14, 18, 22 together and set a maximum opening of the FBVT 10 thus  
24 preventing excessive opening of the FBVT 10. The number, the location and the size  
25 of the restrictors 90 can vary while remaining within the scope of the invention.

26 **[63]** A FBVT 10 is located on the upper portion 70 of the protection garment 66  
27 in a closed position, as seen in Figure 12, and in an open position as seen in Figure  
28 13. A FBVT 10 is located on the lower portion 74 of the protection garment 66,  
29 behind the knee and is depicted in a closed position in Figure 14 and in an open  
30 position in Figure 15. A long FBVT 10 is illustrated and its opening is controlled by its  
31 associated restrictor 90. Two or more shorter FBVT 10 could alternatively be used  
32 instead of a long FBVT 10 without departing from the scope of the invention. Figure

**MTC-157-004-CA1**

1 16 illustrates a sectional view of a FBVT 10 on the upper portion 70 of the safety  
2 garment 66 to appreciate its configuration in more details. Figure 17 depicts a  
3 cooling flow of air between two FBVT 10 in accordance with another embodiment of  
4 the invention using collectively a plurality of FBVT 10 to vent a protection garment  
5 66. And finally, Figure 18 provides another view of a convected coverall 70 equipped  
6 with a plurality of FBVT 10 in accordance with an embodiment of the invention.

7 **[64]** The description and the drawings that are presented above are meant to  
8 be illustrative of the present invention. They are not meant to be limiting of the  
9 scope of the present invention. Modifications to the embodiments described may be  
10 made without departing from the present invention, the scope of which is defined by  
11 the following claims:

12

What is claimed is:

1. A flame blocking venting trap (FBVT) adapted to vent a garment, the FBVT comprising:

a proximal layer, the proximal layer including a proximal side and a distal side thereof;

a central venting layer superposed and connected to the proximal layer at a first side thereof, the central venting layer including a proximal side and a distal side thereof; and

a distal layer superposed and connected to the central venting layer at a second side thereof, the distal layer including a proximal side and a distal side thereof,

wherein the superposed proximal layer, central venting layer and distal layer are configured to route air from outside the FBVT, through the proximal side of the central venting layer, inside the FBVT, in a direction toward the proximal side of the distal layer, wherein the proximal layer and the distal layer are configured to block the venting layer when the proximal layer and the distal layer are compressed toward the central venting layer.

2. The flame blocking venting trap of claim 1, wherein the proximal layer is forming a first fold with the central venting layer and the central venting layer is forming a second fold with the distal layer.

3. The flame blocking venting trap of any of claim 1 and claim 2, wherein the proximal layer and the distal layer are configured to allow air to go through the venting layer when the proximal layer and the distal layer are distanced from the central venting layer.

4. The flame blocking venting trap of claim 3, wherein the proximal layer and the distal layer are configured to be distanced from the central venting layer when a flow of air is directed from the wearer-side toward the environment-side.
5. The flame blocking venting trap of any one of claim 1 to claim 4, wherein the venting layer comprises a mesh portion.
6. The flame blocking venting trap of any one of claim 1 to claim 5, wherein the venting layer comprises two fabric portions longitudinally extending on each side of a mesh portion.
7. The flame blocking venting trap of claim 6, wherein the two fabric portions are respectively adjacent with a first fold interconnecting the proximal layer with the central venting layer and a second fold interconnecting the central layer with the distal layer.
8. The flame blocking venting trap of any one of claim 1 to claim 7, wherein the venting layer comprises one fabric portion longitudinally extending on a side of a mesh portion adjacent to the proximal layer.
9. The flame blocking venting trap of claim 8, wherein the one fabric portion is interconnected with the proximal layer to create a cavity.
10. A garment comprising a flame blocking venting trap (FBVT) adapted to vent the garment, the flame blocking coverall comprising:
  - a proximal layer, the proximal layer including a proximal side and a distal side thereof;

a central venting layer superposed and connected to the proximal layer at a first side, the central venting layer including a proximal side and a distal side thereof; and

a distal layer superposed and connected to the central venting layer at a second side, the distal layer including a proximal side and a distal side thereof, wherein the superposed proximal layer, central venting layer and distal layer are configured to route air from outside the FBVT, through the proximal side of the central venting layer, inside the FBVT, in a direction toward the proximal side of the distal layer, wherein the proximal layer and the distal layer are configured to block the venting layer when the proximal layer and the distal layer are compressed toward the central venting layer.

11. The garment of claim 10, wherein the proximal layer is forming a first fold with the central venting layer and the central venting layer is forming a second fold with the distal layer.

12. The garment of any of claim 10 and claim 11, wherein the proximal layer and the distal layer are configured to allow air to go through the venting layer when the proximal layer and the distal layer are distanced from the central venting layer.

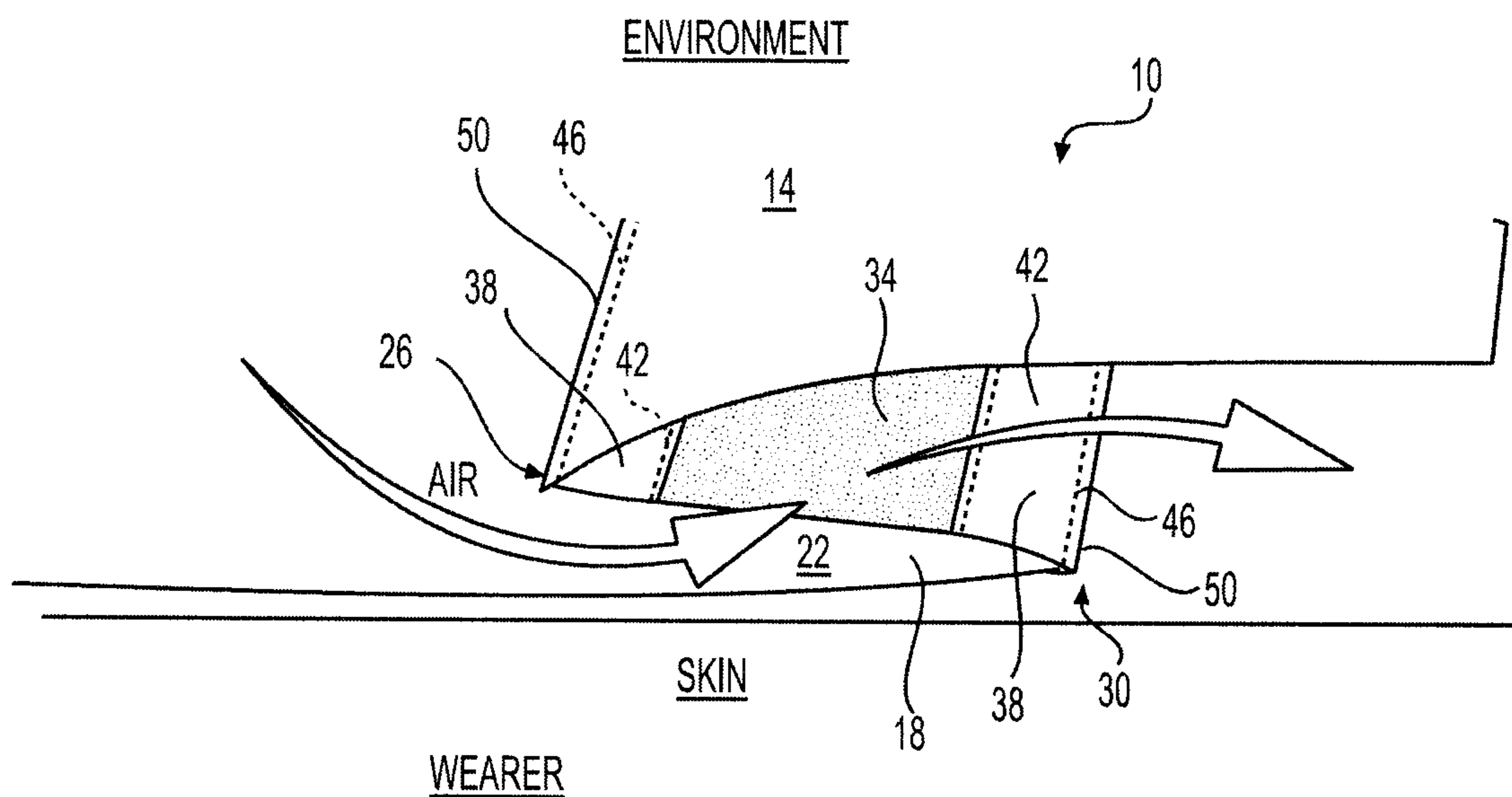
13. The garment of claim 12, wherein the proximal layer and the distal layer are configured to be distanced from the central venting layer when a flow of air is directed from the wearer-side toward the environment-side.

14. The garment of any one of claim 10 to claim 13, wherein the venting layer comprises a mesh portion.

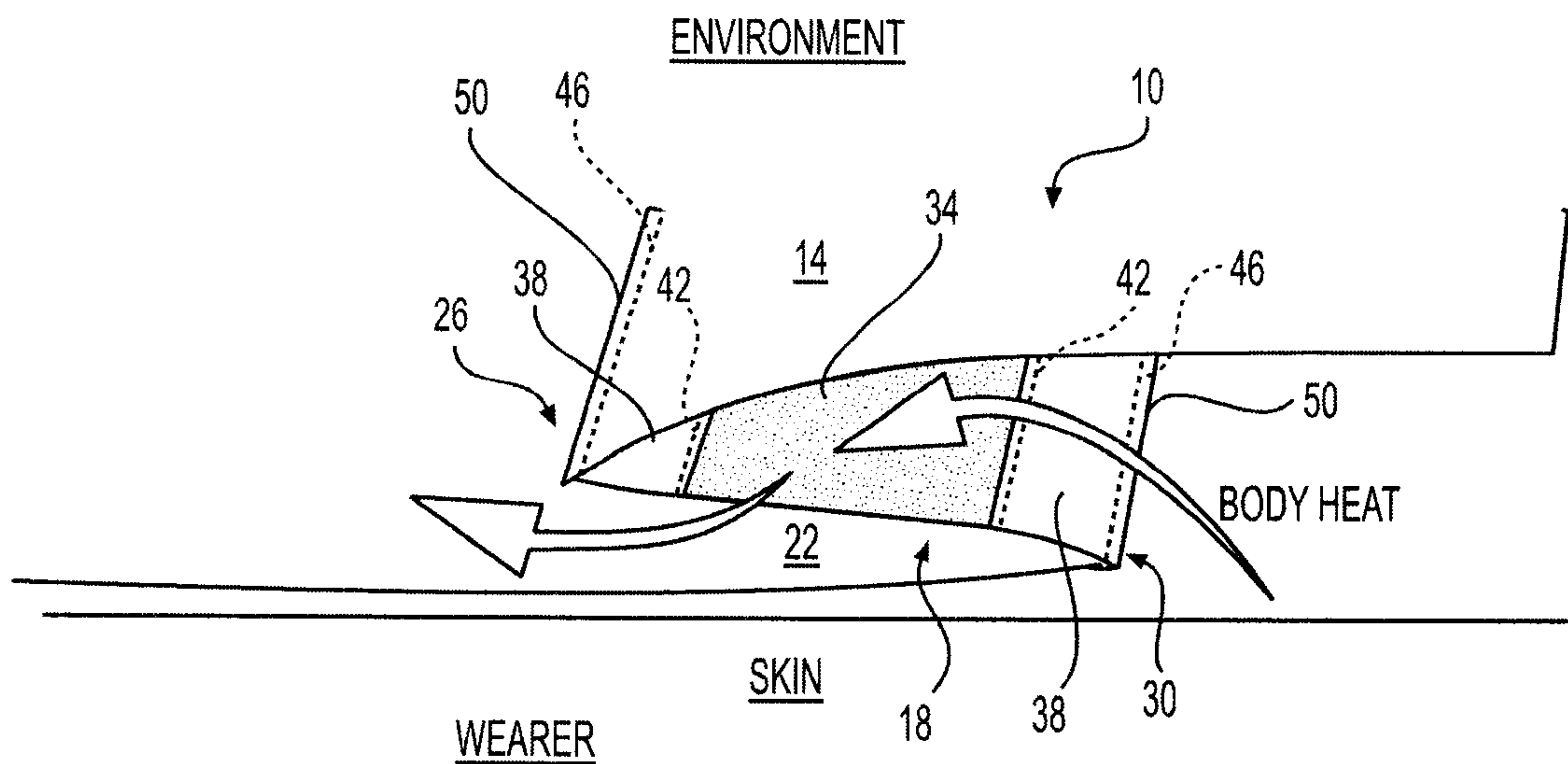
15. The garment of any one of claim 10 to claim 14, wherein the venting layer comprises two fabric portions longitudinally extending on each side of a mesh portion.
16. The garment of claim 15, wherein the two fabric portions are respectively adjacent with a first fold interconnecting the proximal layer with the central venting layer and a second fold interconnecting the central layer with the distal layer.
17. The garment of any one of claim 10 to claim 16, wherein the venting layer comprises one fabric portion longitudinally extending on a side of a mesh portion adjacent to the proximal layer.
18. The garment of claim 17, wherein the one fabric portion is interconnected with the proximal layer to create a cavity.



2/14

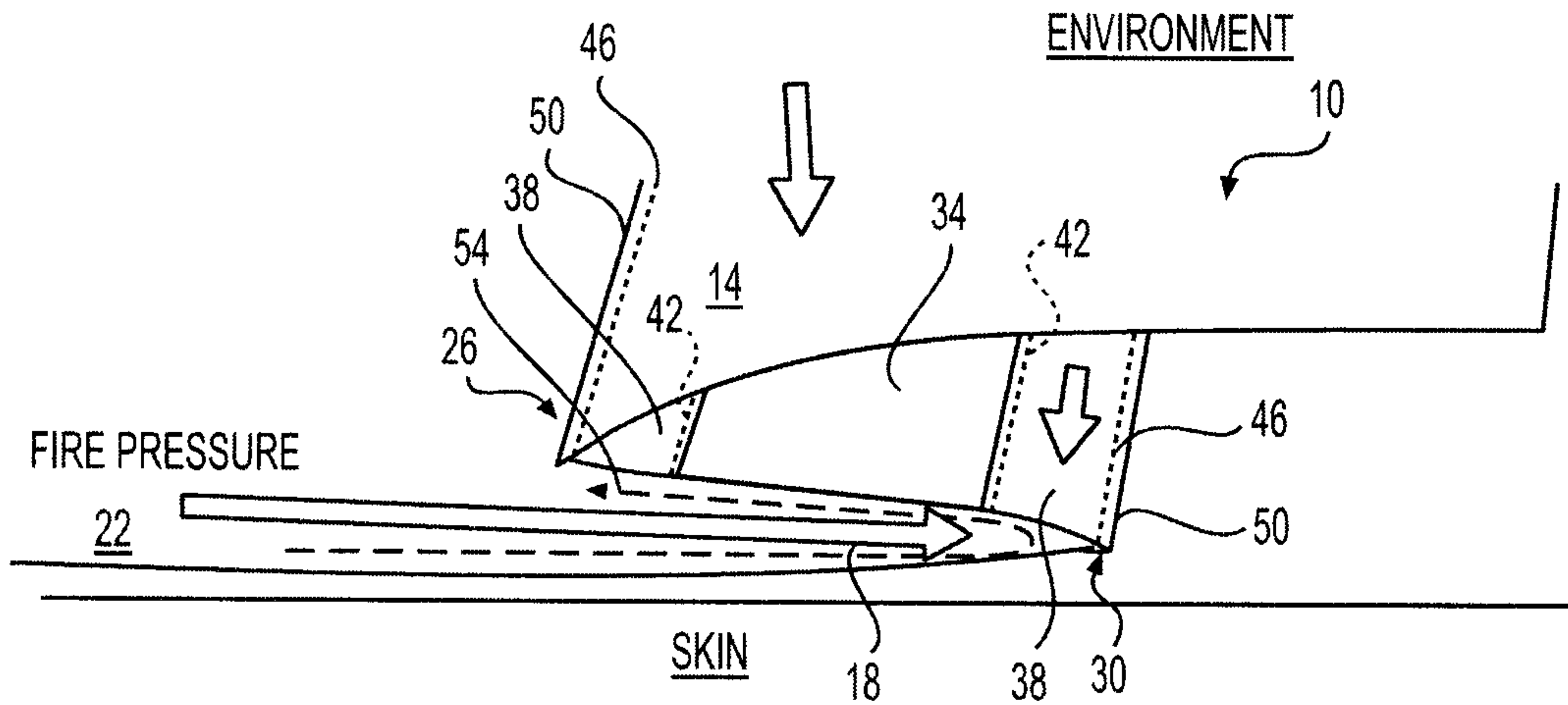


**FIG. 2**

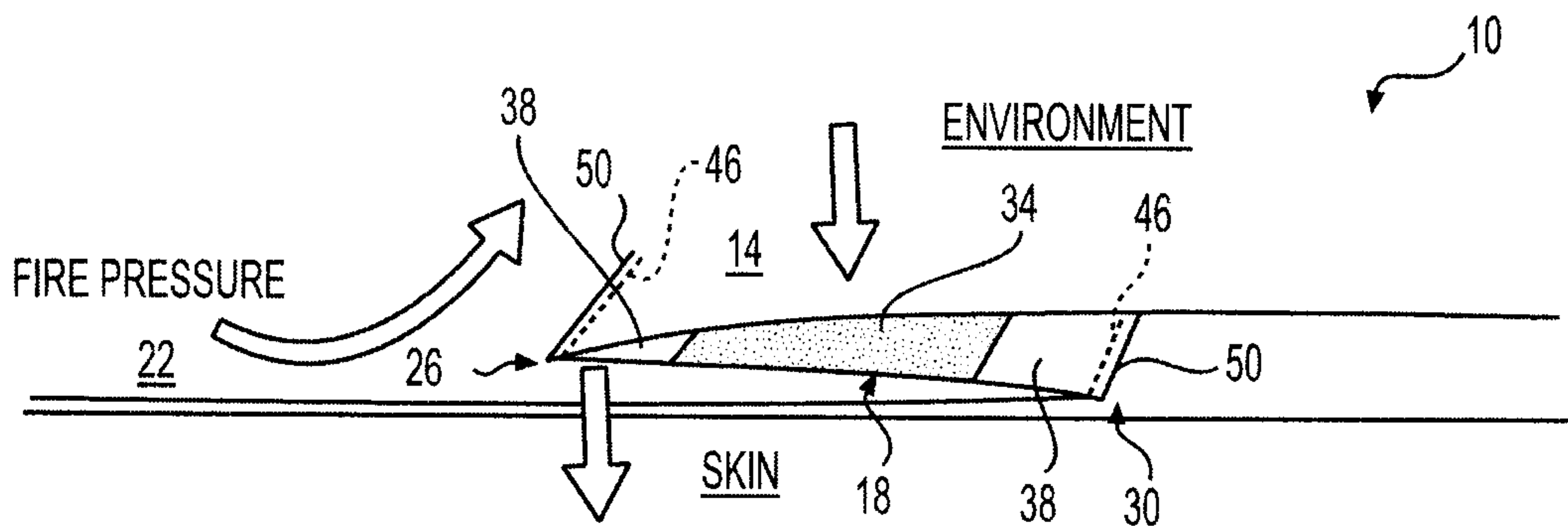


**FIG. 3**

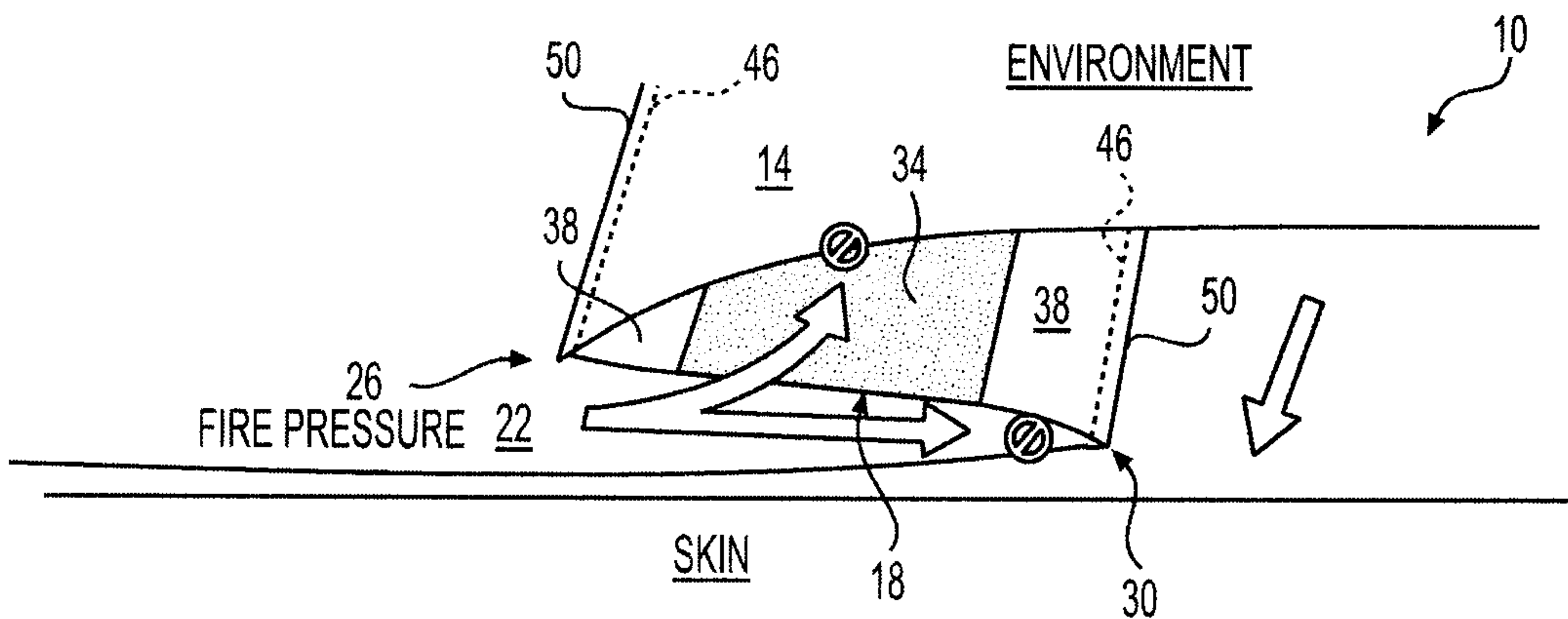
3/14



**FIG. 4**

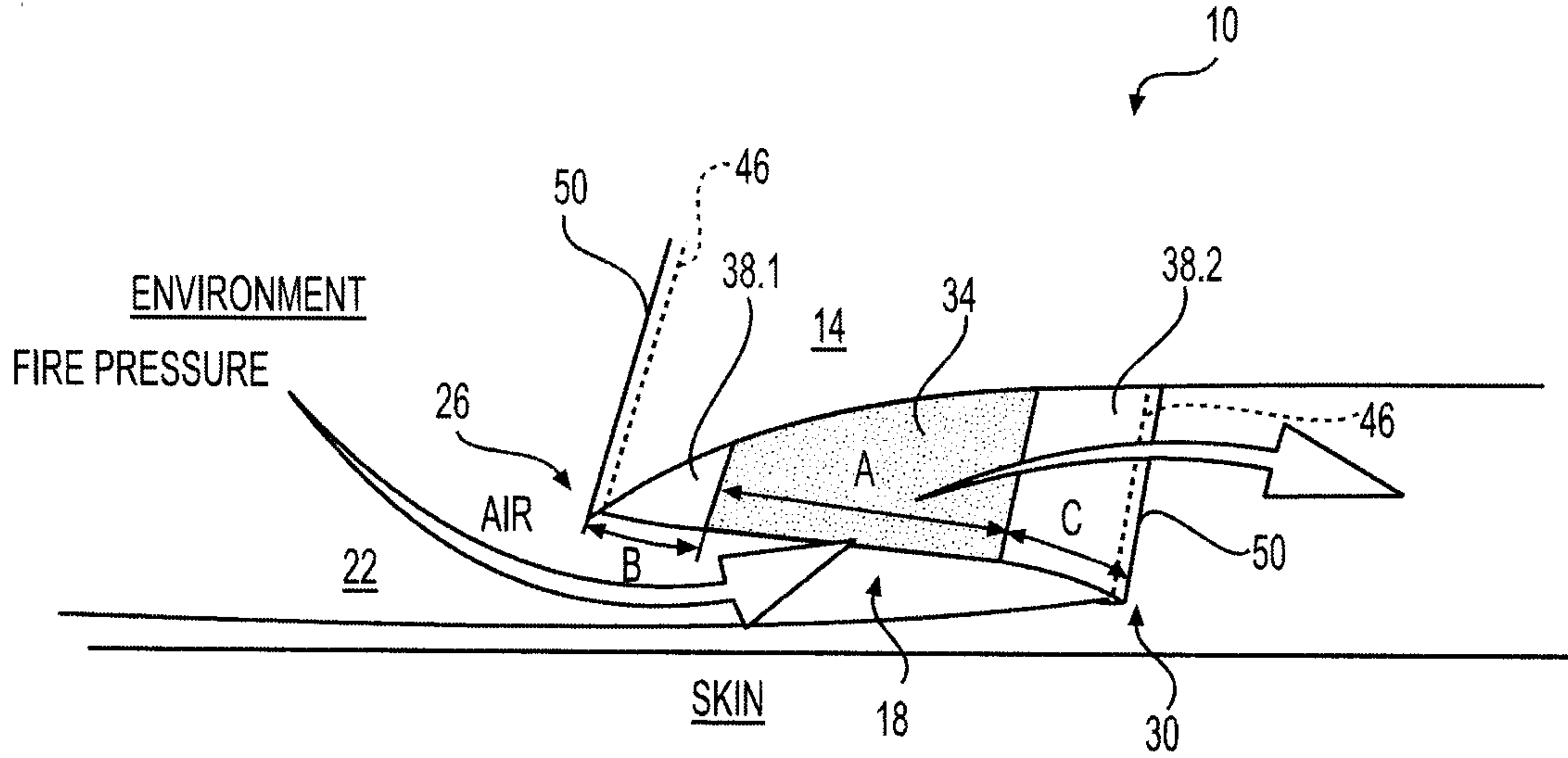


**FIG. 5**

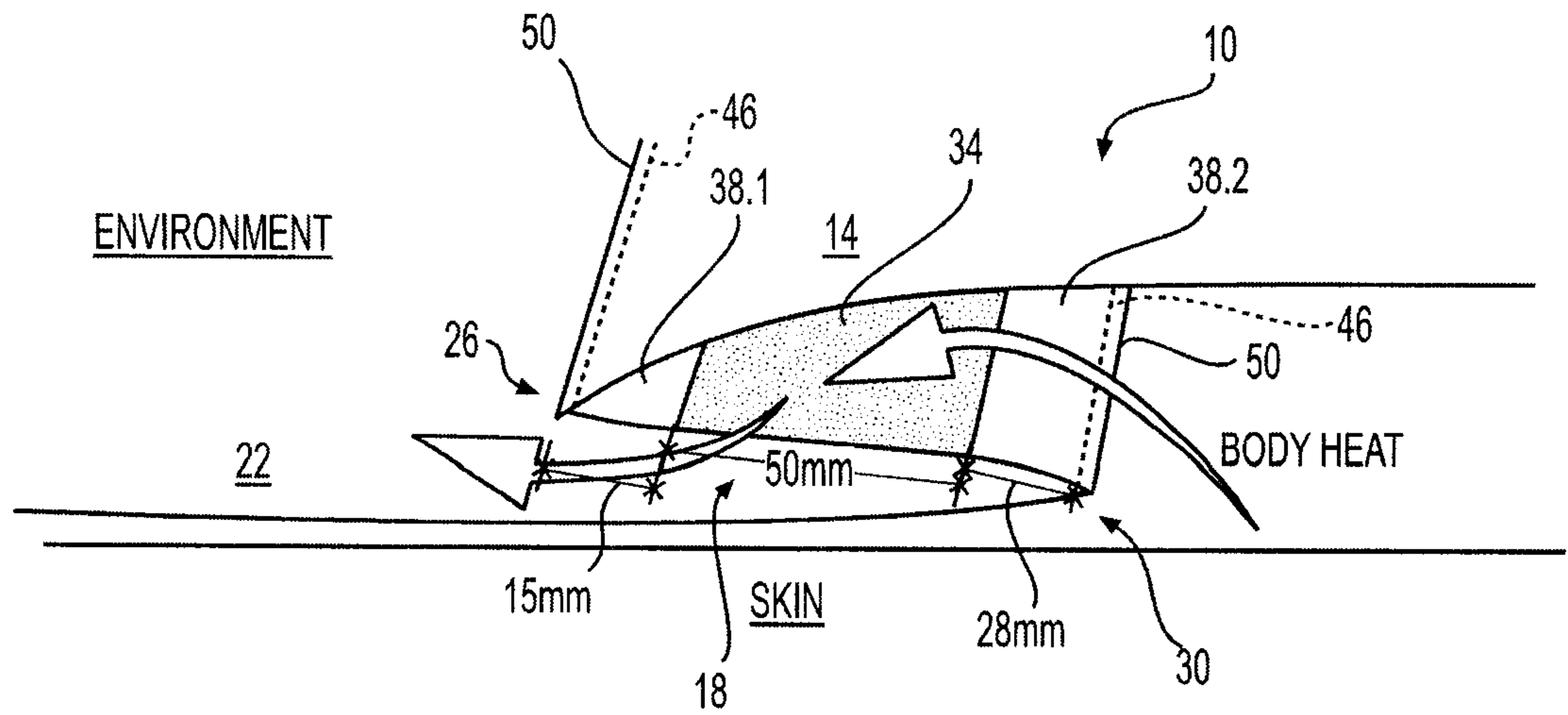


**FIG. 6**

4/14

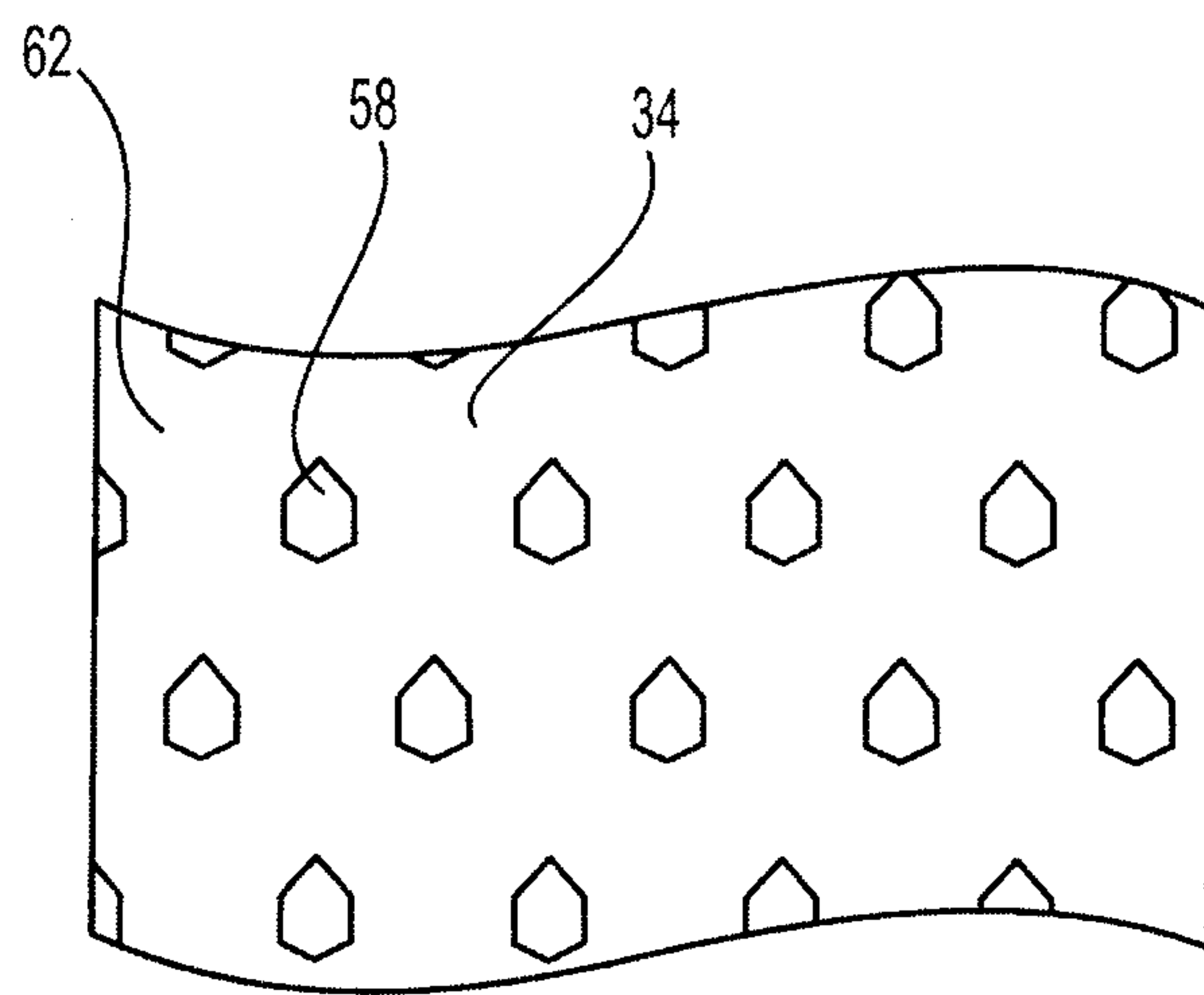


**FIG. 7**



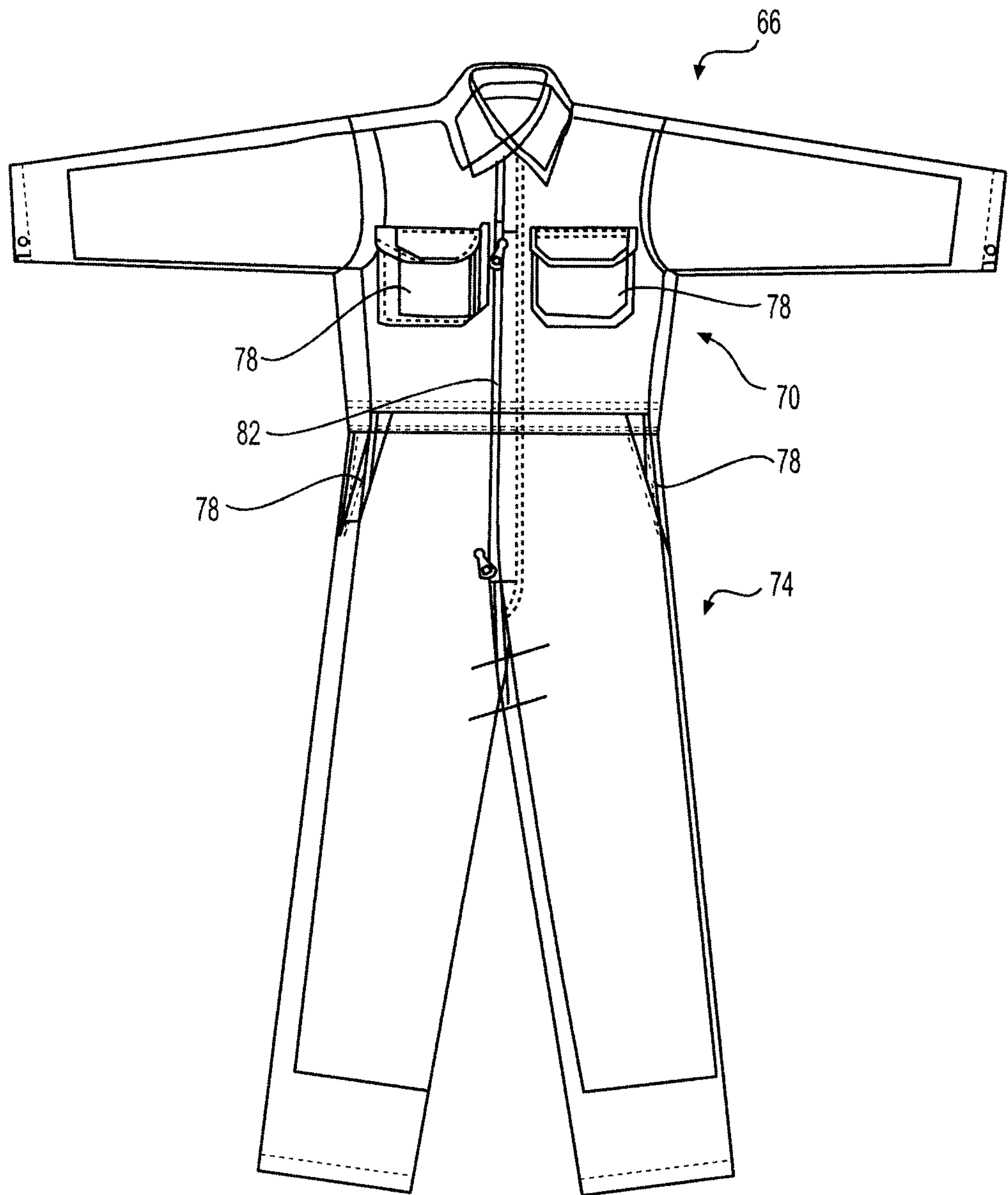
**FIG. 8**

5/14



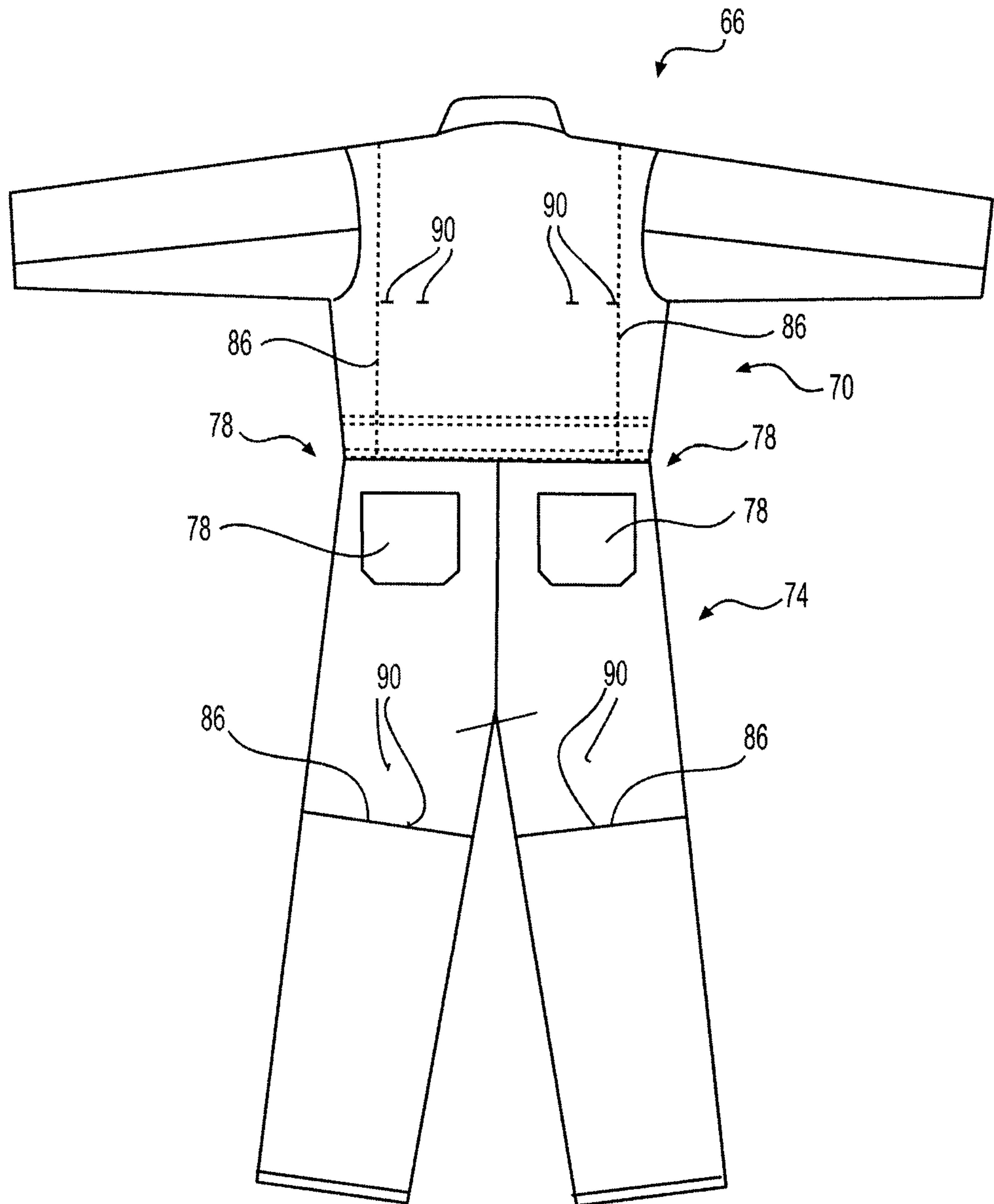
**FIG. 9**

6/14

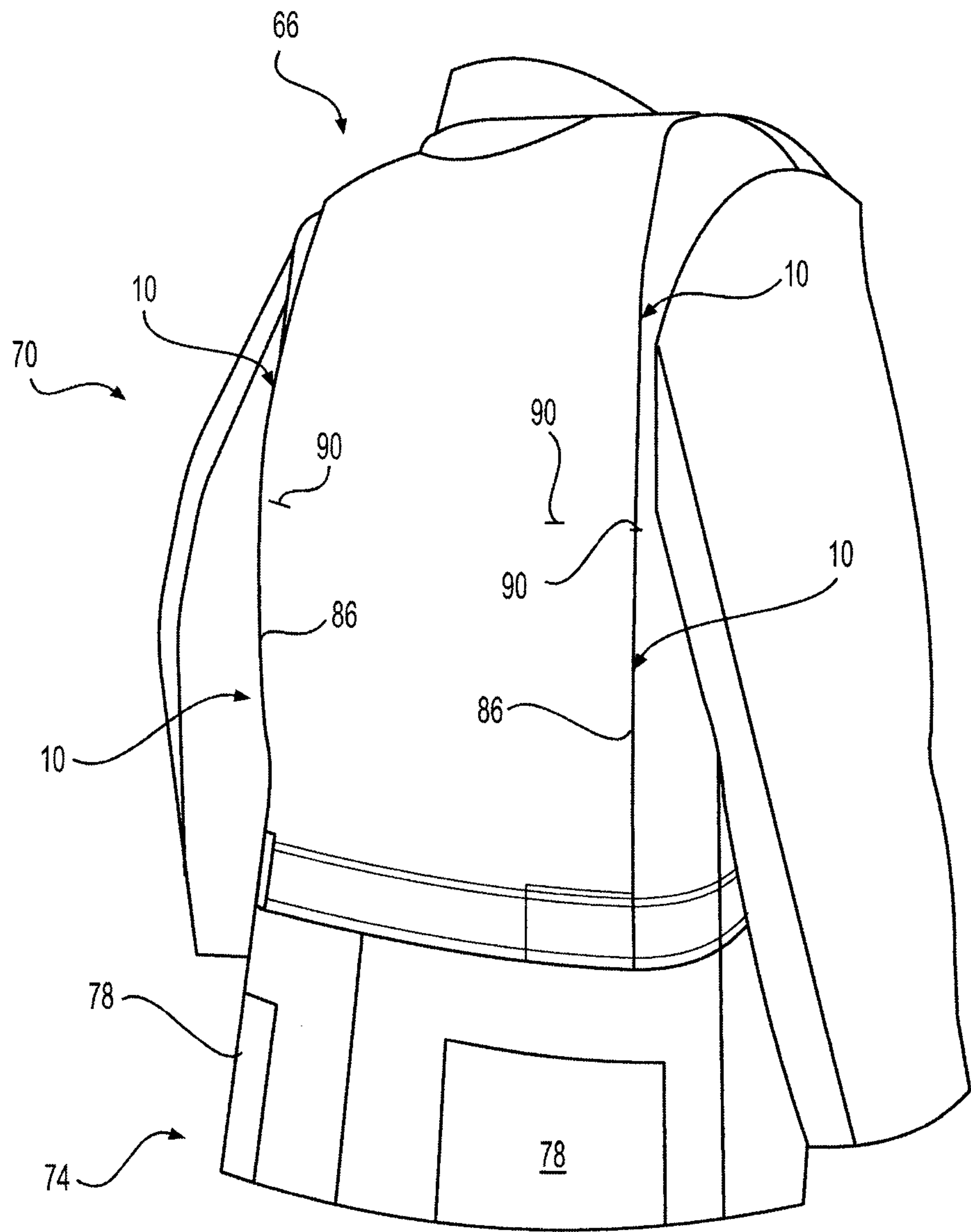


**FIG. 10**

7/14

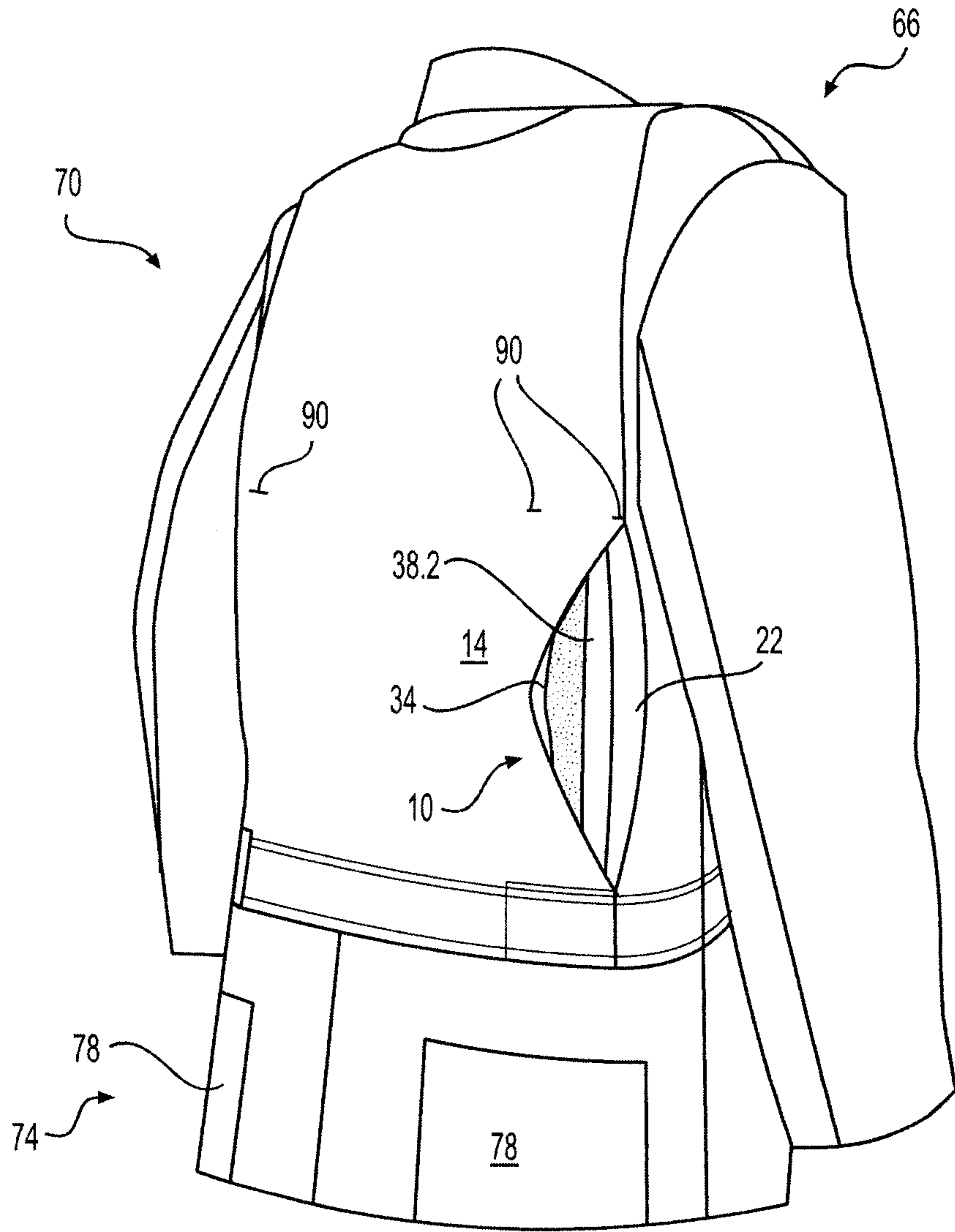


**FIG. 11**



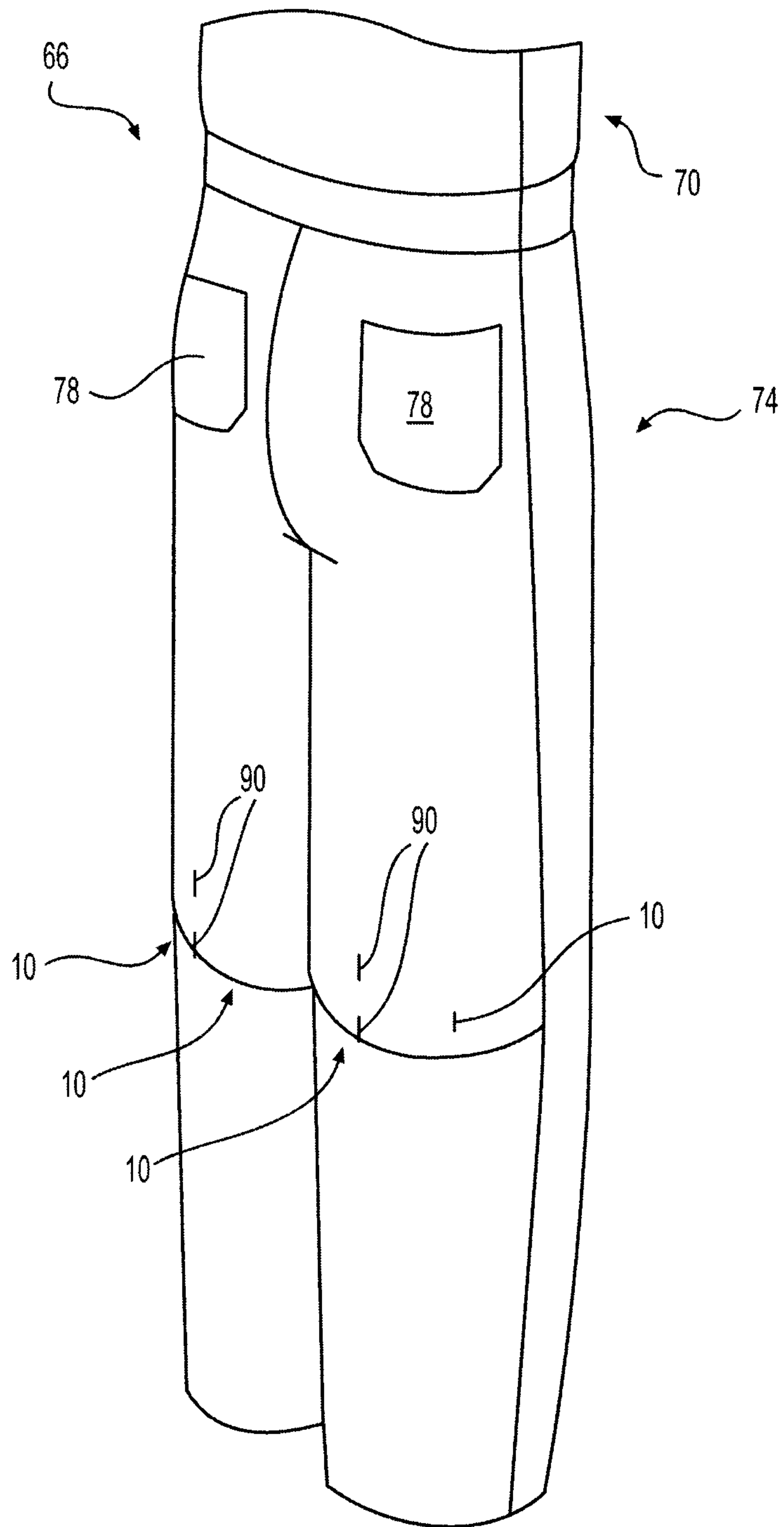
**FIG. 12**

9/14



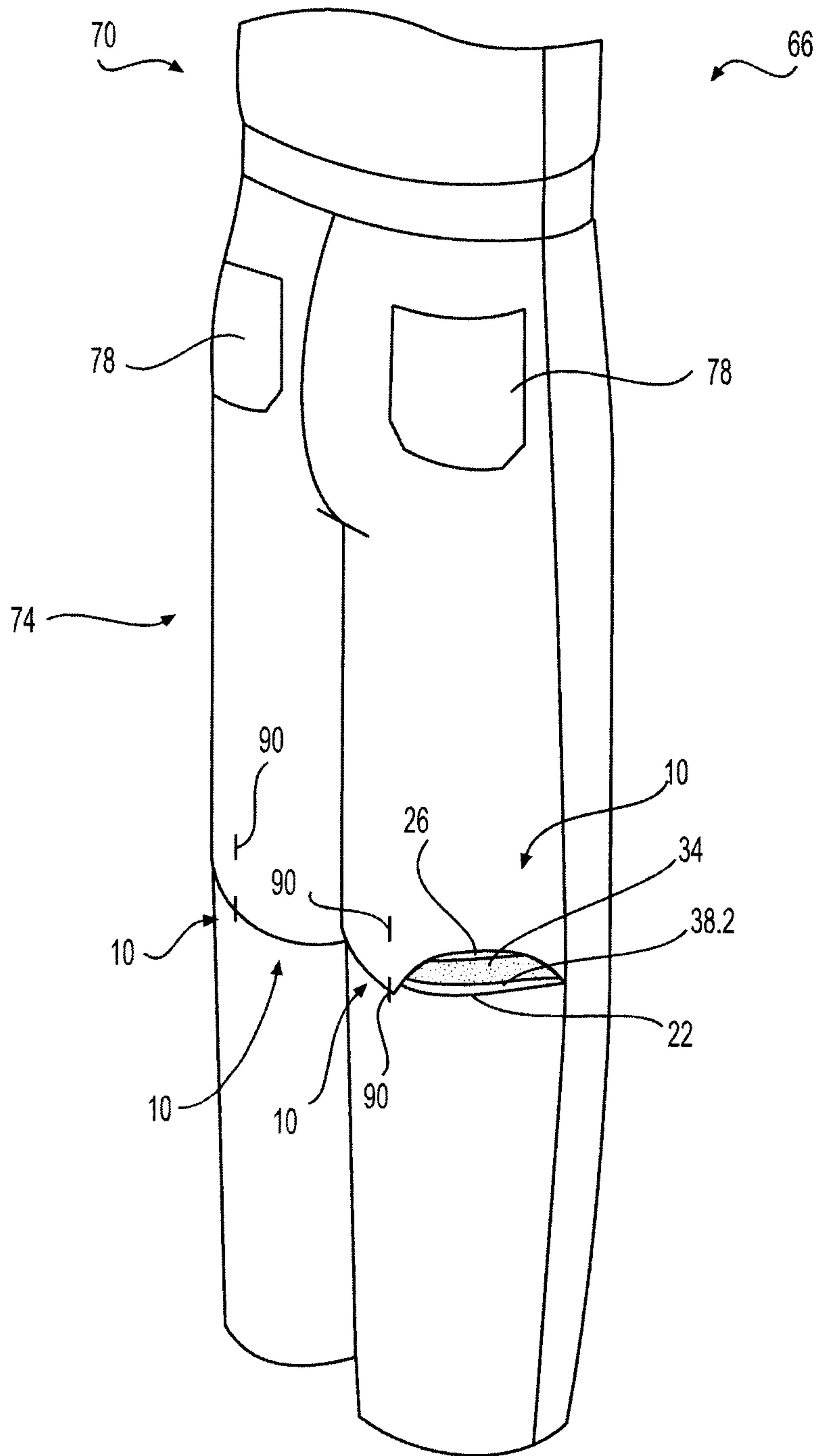
**FIG. 13**

10/14



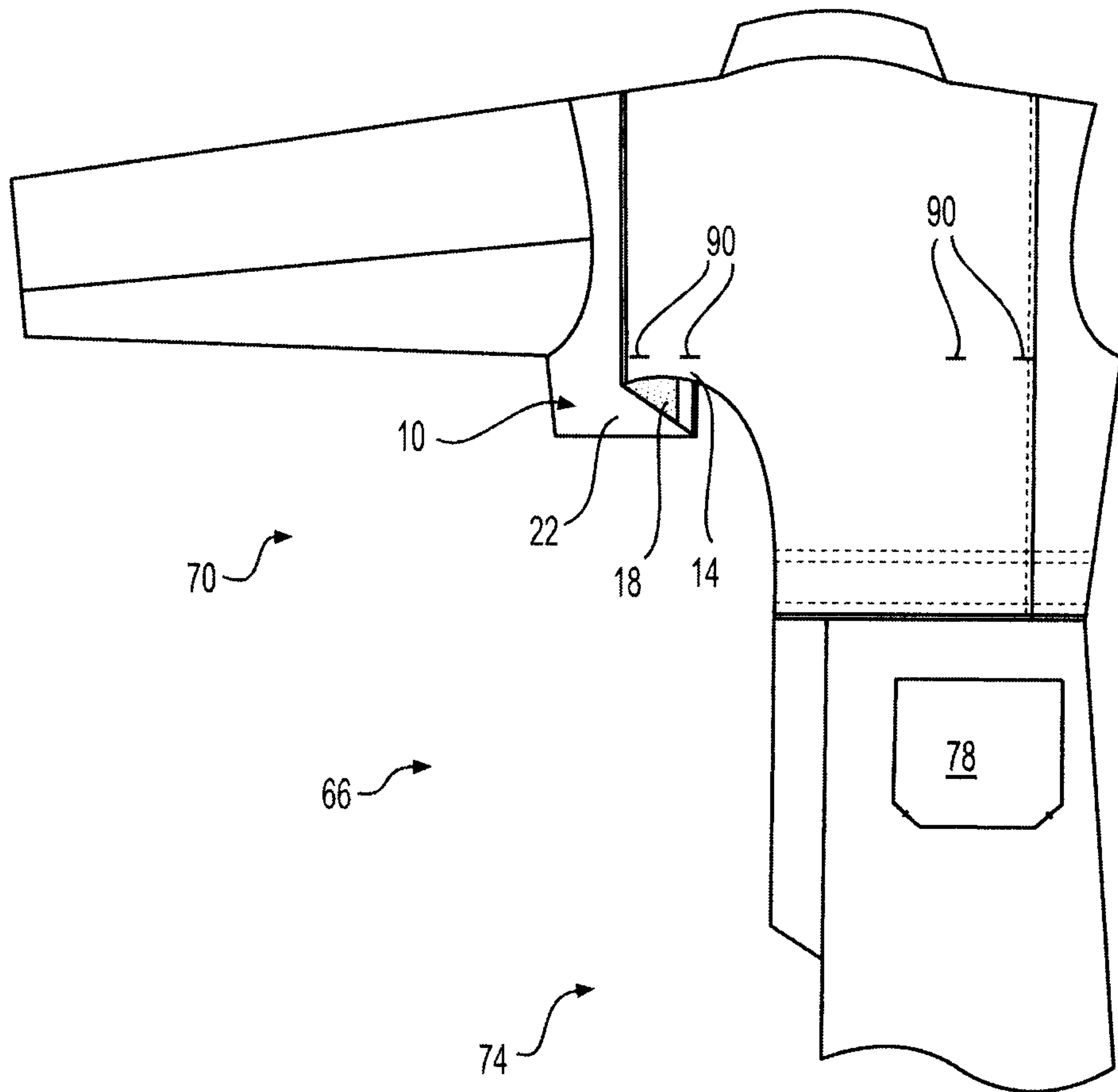
**FIG. 14**

11/14



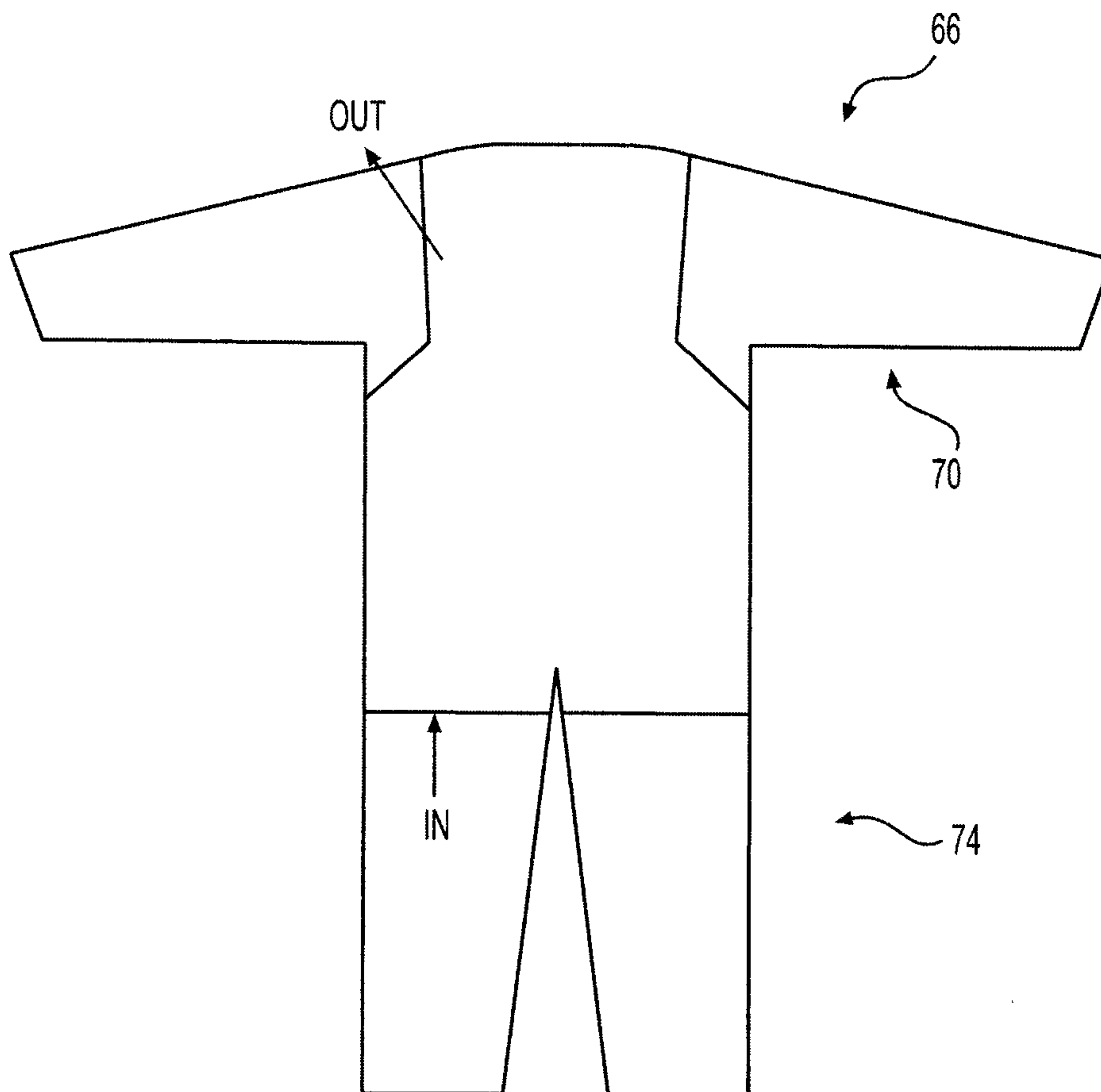
**FIG. 15**

12/14



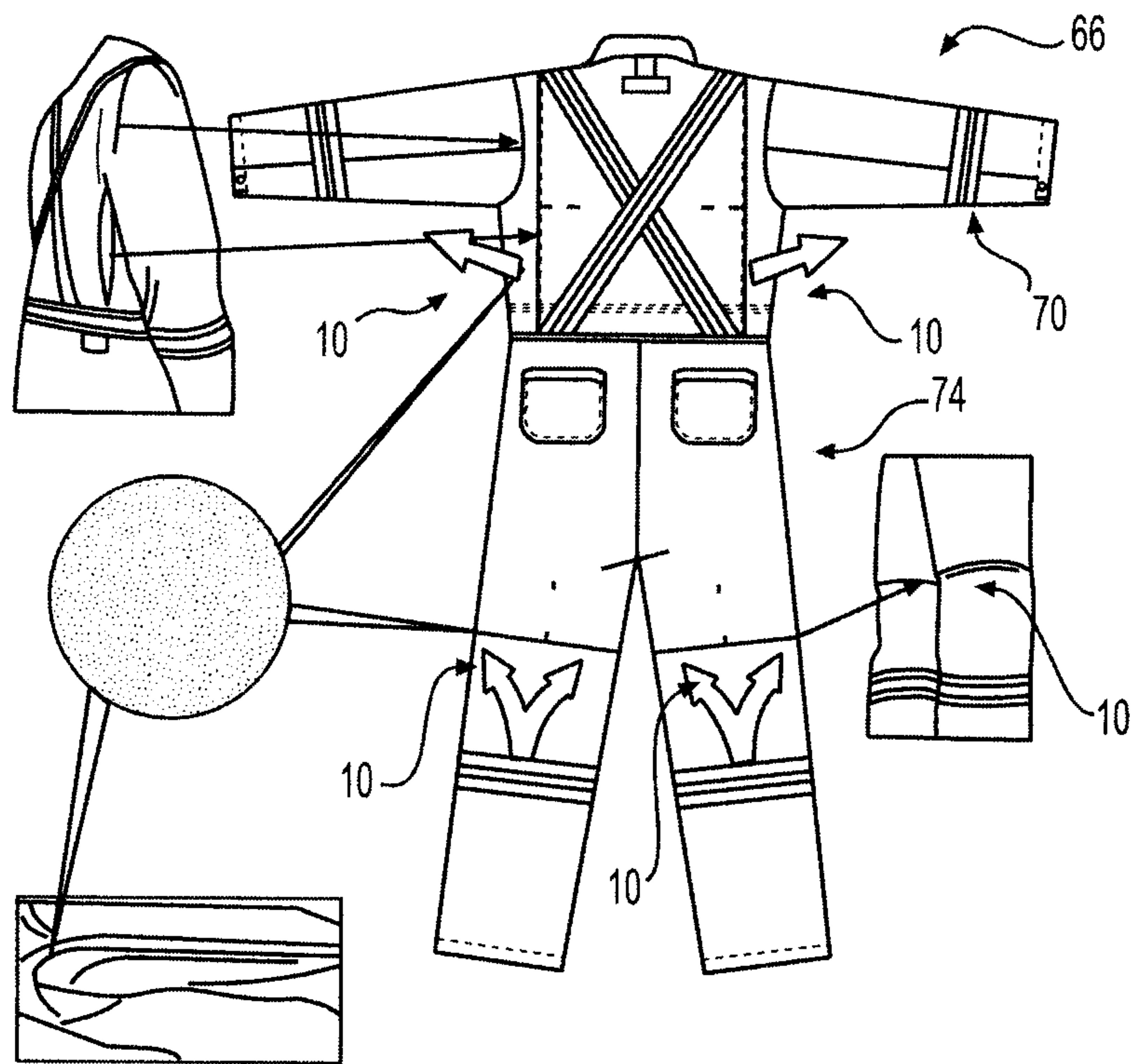
**FIG. 16**

13/14



**FIG. 17**

14/14



**FIG. 18**

