



US 20110130253A1

(19) **United States**

(12) **Patent Application Publication**
Fuller

(10) **Pub. No.: US 2011/0130253 A1**

(43) **Pub. Date: Jun. 2, 2011**

(54) **EXERCISE AND FITNESS SYSTEM**

Publication Classification

(76) Inventor: **Conrad R. Fuller**, Salt Lake City, UT (US)

(51) **Int. Cl.**
A63B 21/02 (2006.01)

(21) Appl. No.: **12/790,788**

(52) **U.S. Cl.** **482/122**

(22) Filed: **May 28, 2010**

(57) **ABSTRACT**

Related U.S. Application Data

(63) Continuation-in-part of application No. 11/450,114, filed on Jun. 9, 2006, now abandoned, Continuation of application No. 12/258,714, filed on Oct. 27, 2008, now abandoned.

An exercise fitness system involves an apparatus comprising a rigid movable booster bar having two flexible elastic elements attached to the booster with an attachment. The attachments are spaced from each other and configured to allow winding the elastic element upon the booster bar by rotating the booster bar. Each flexible elastic element comprises at least two stages of flexible shock cords, with the stages disposed serially along the length of the flexible element, with adjacent stages having a different elastic stiffness.

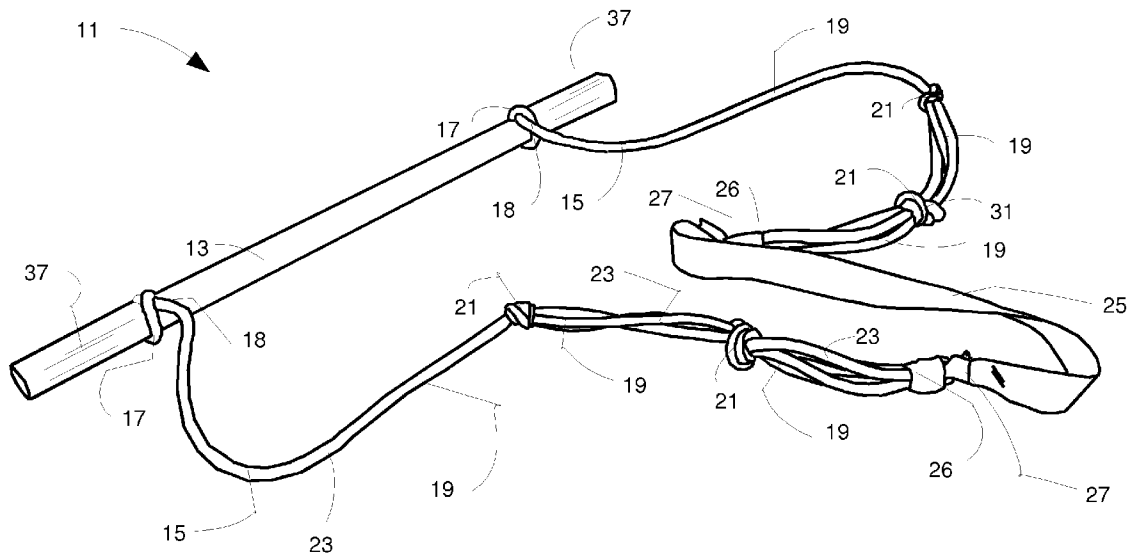

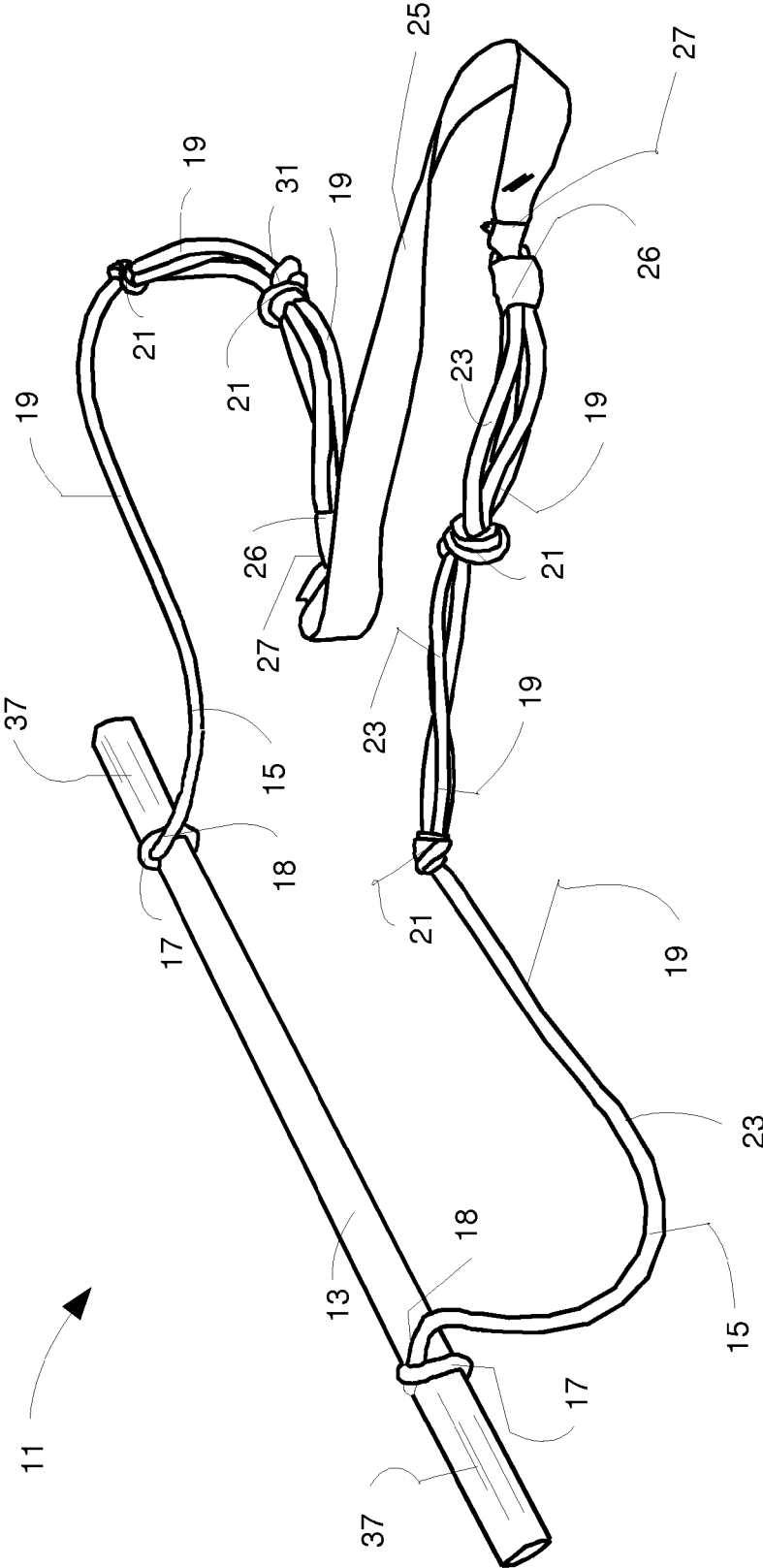

FIG. 1

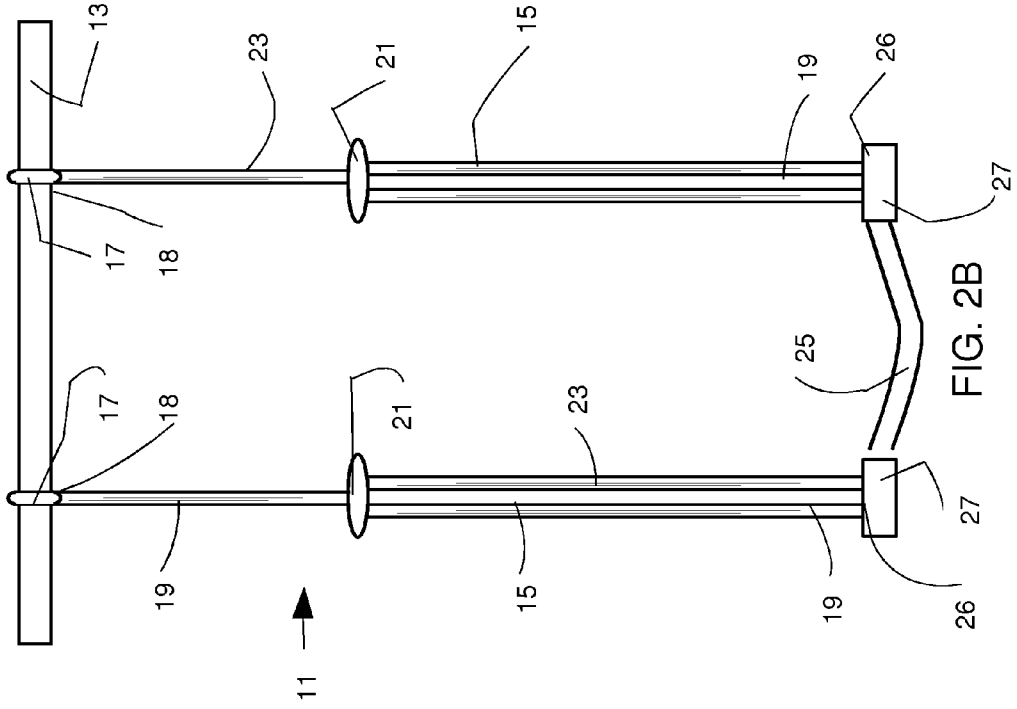

FIG. 2A

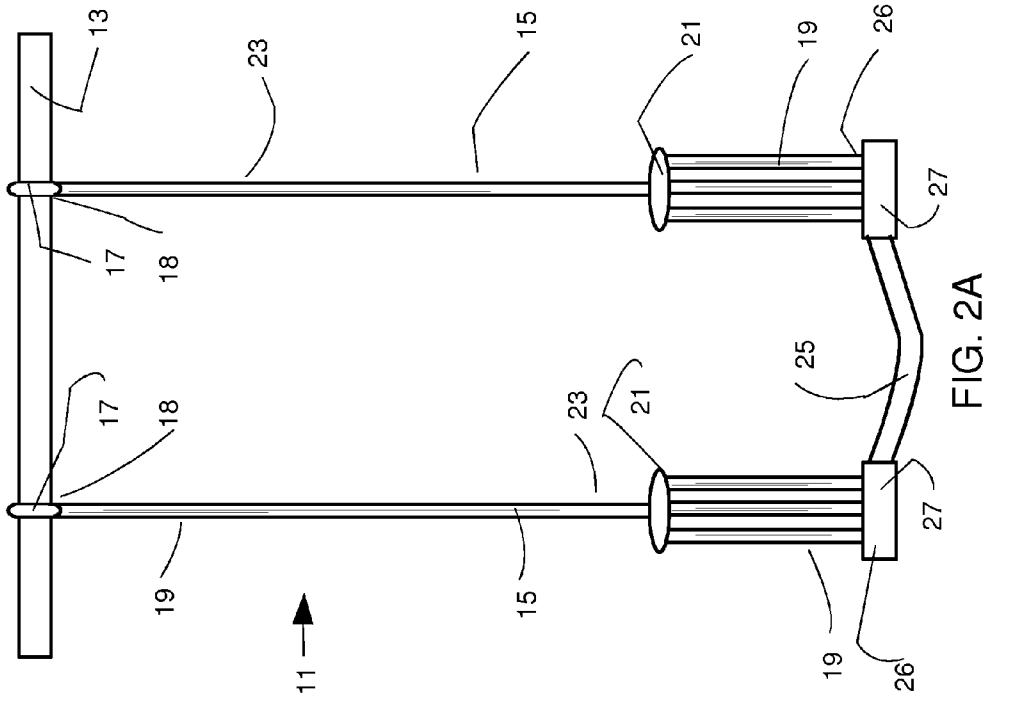
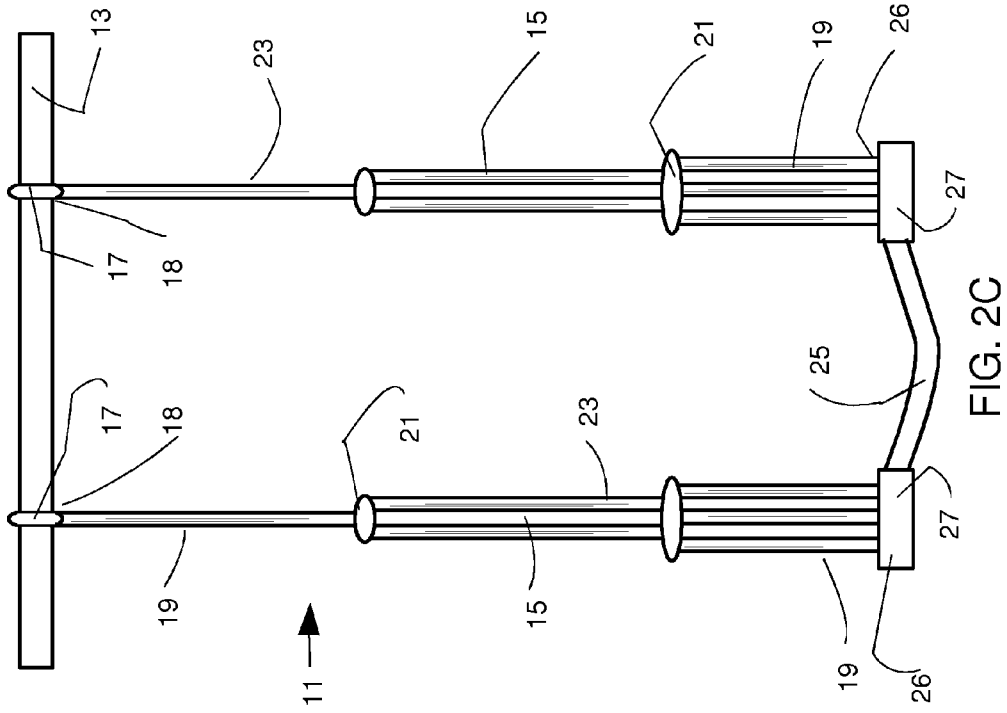
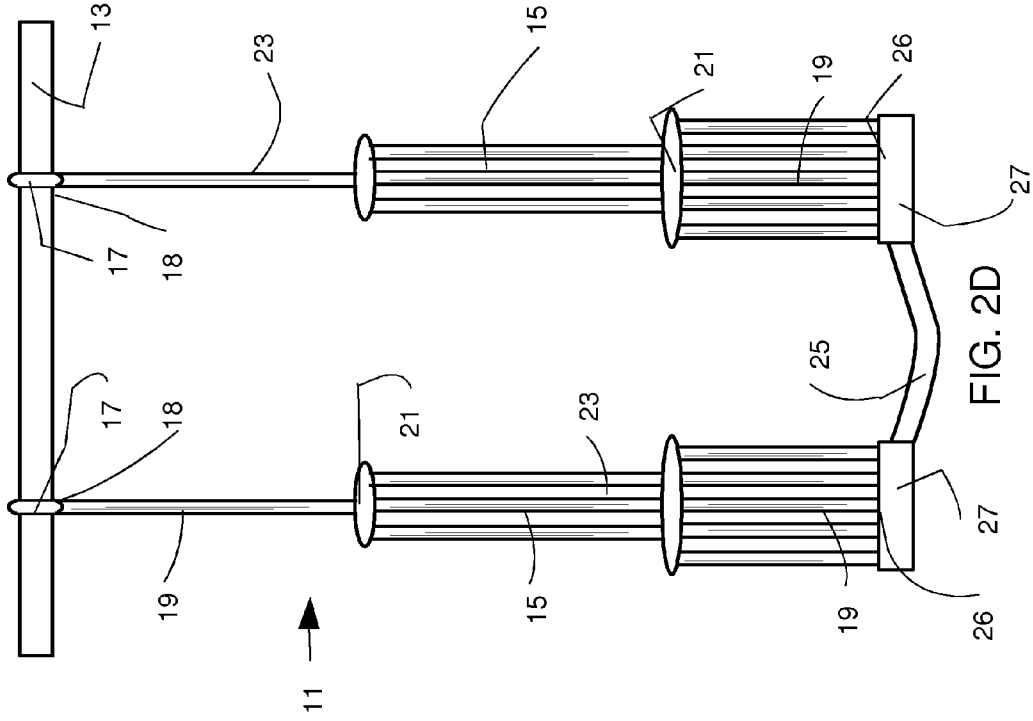

FIG. 2B



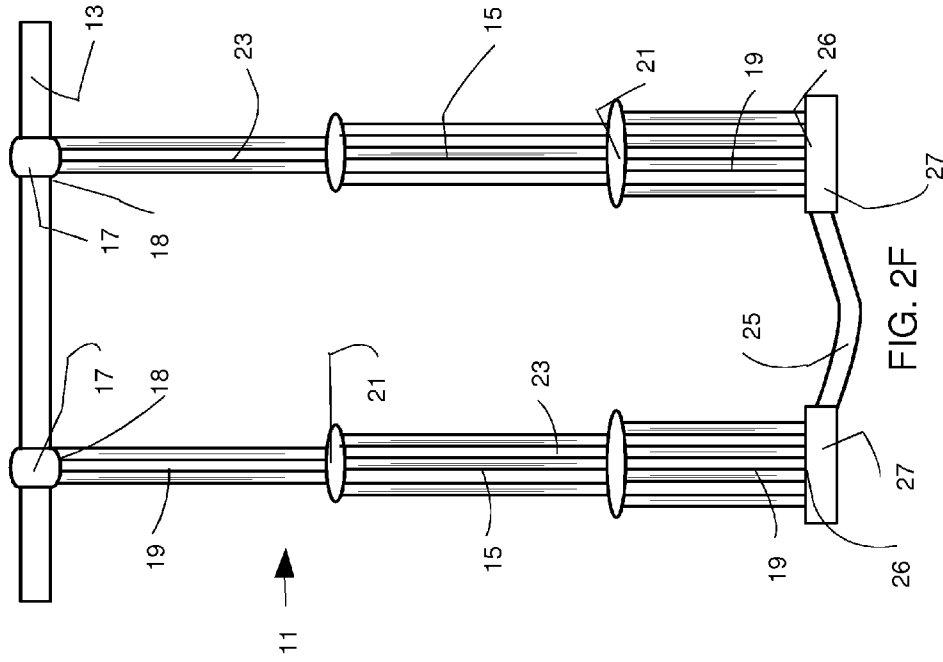

FIG. 2E

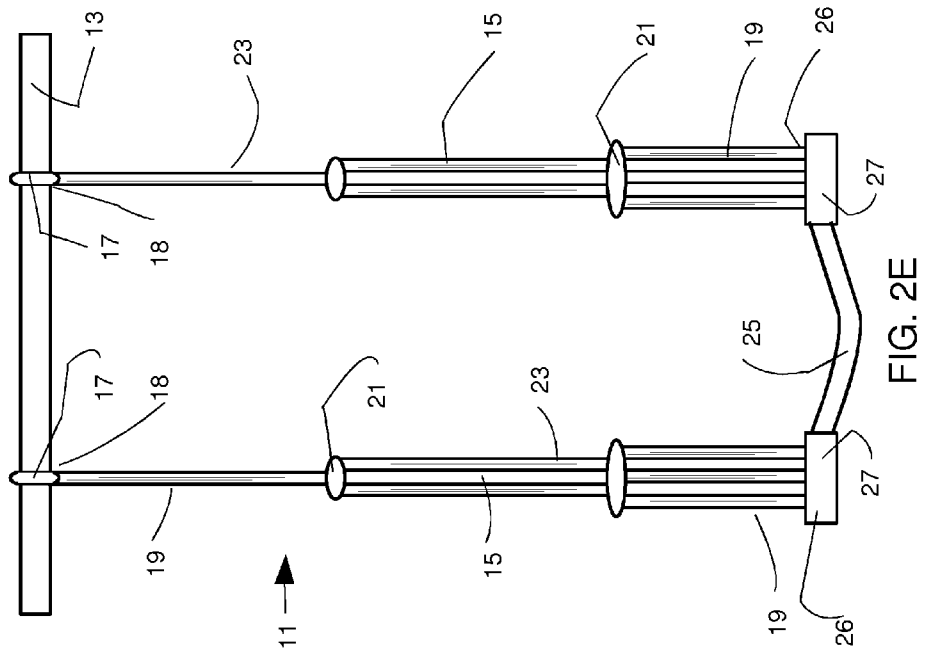
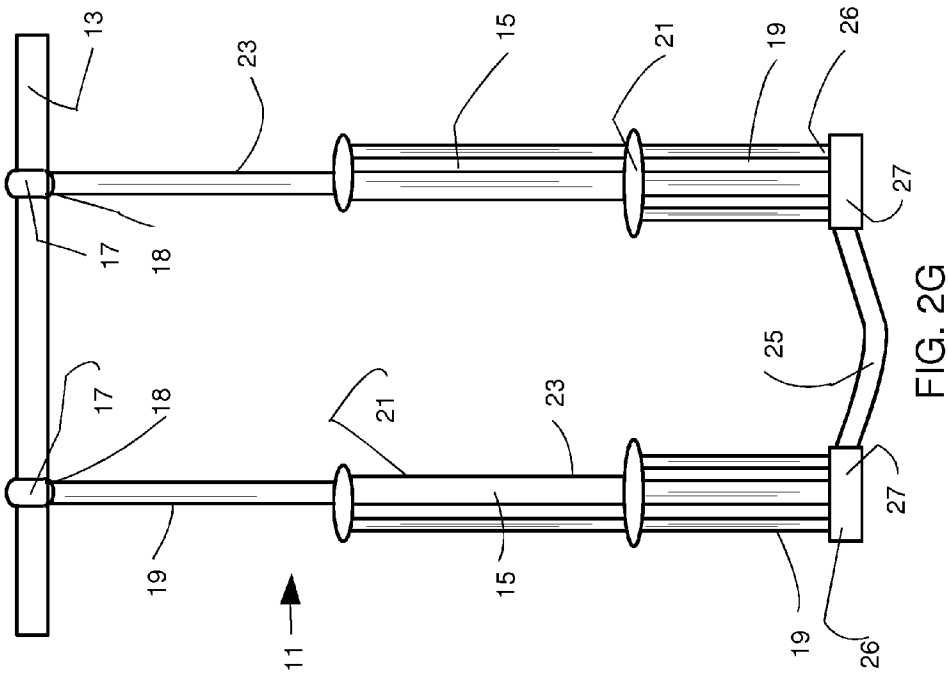
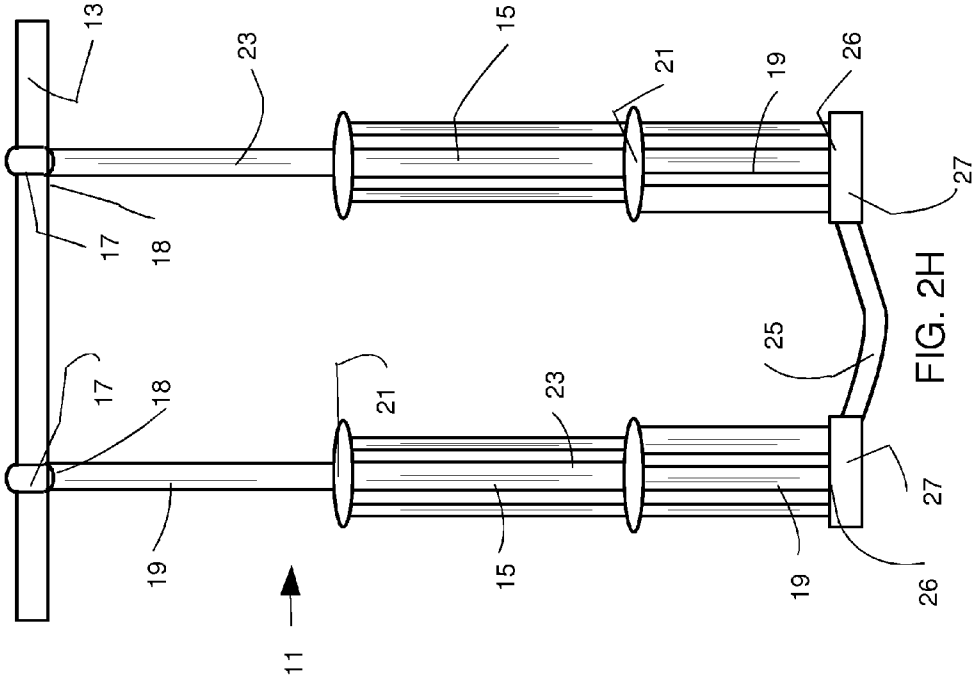

FIG. 2F



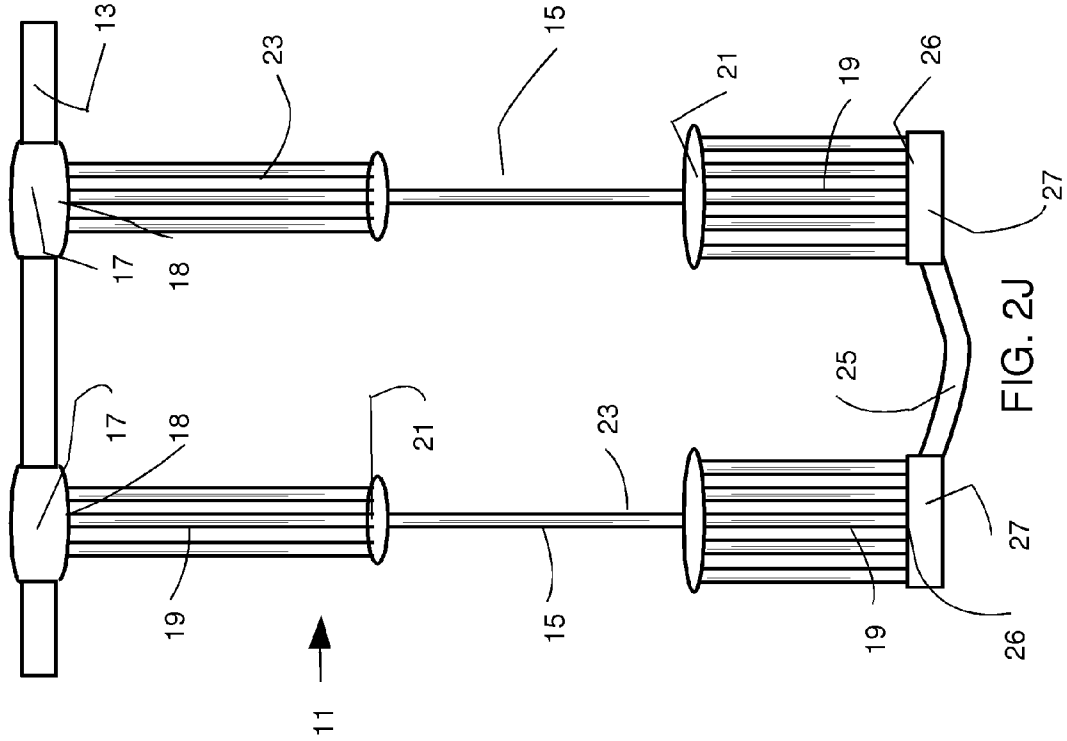

FIG. 2J

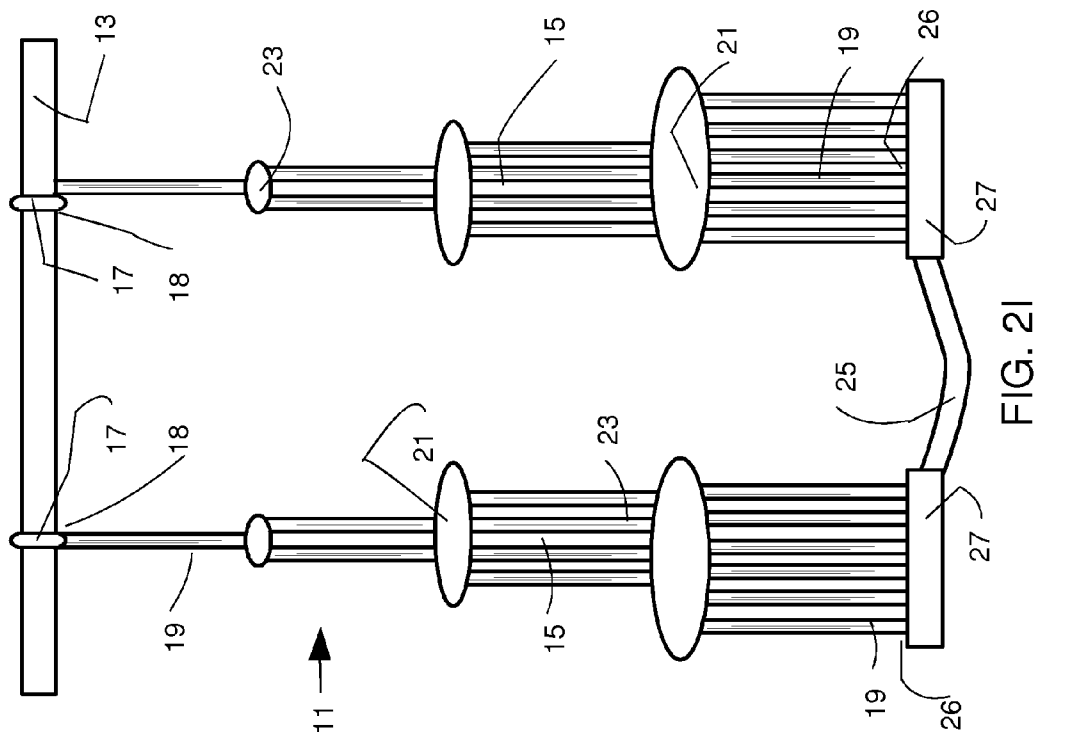

FIG. 2I

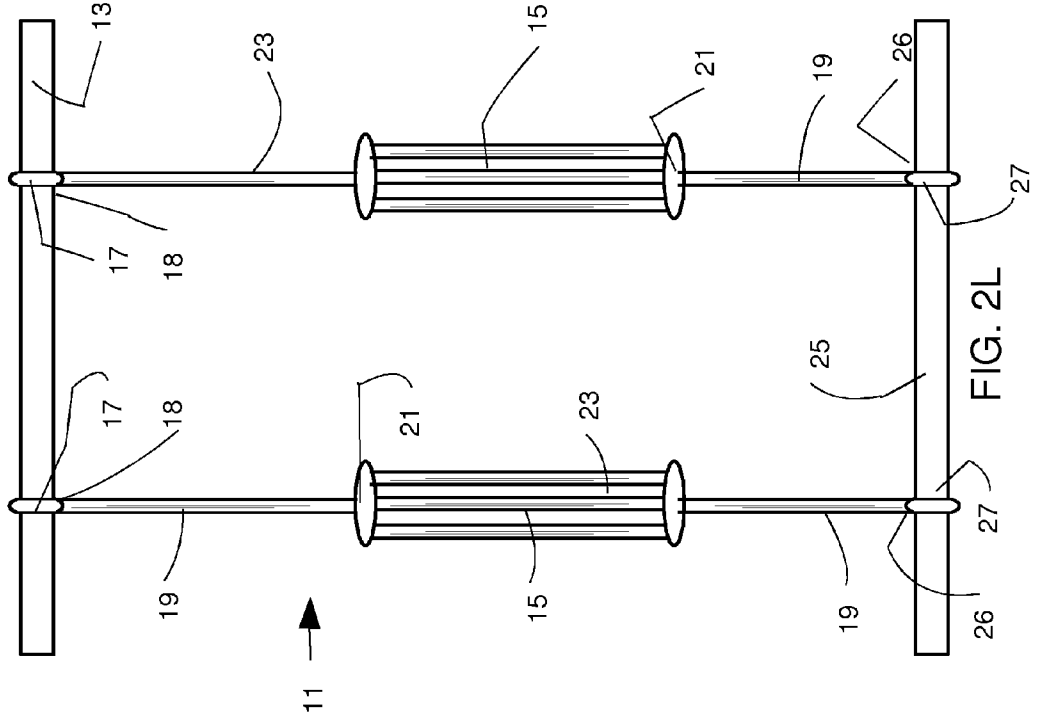

FIG. 2L

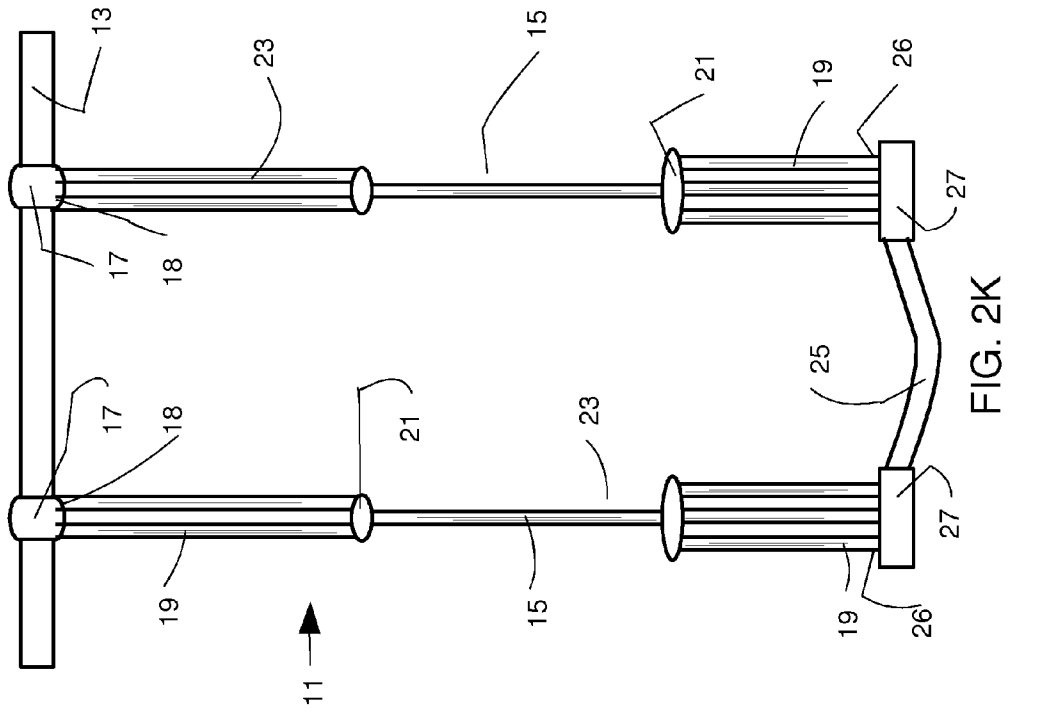

FIG. 2K

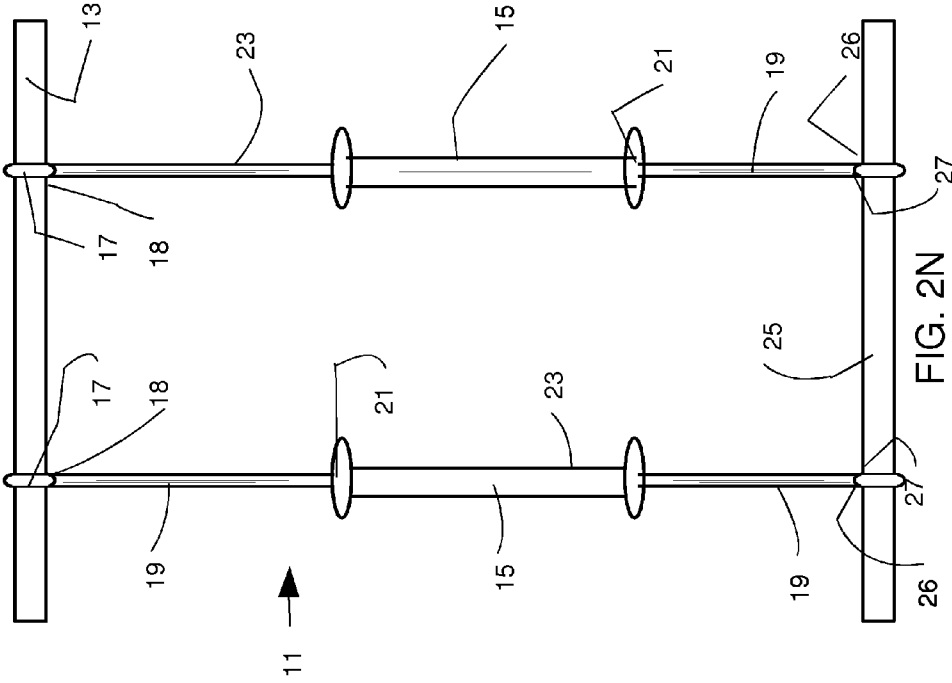

FIG. 2N

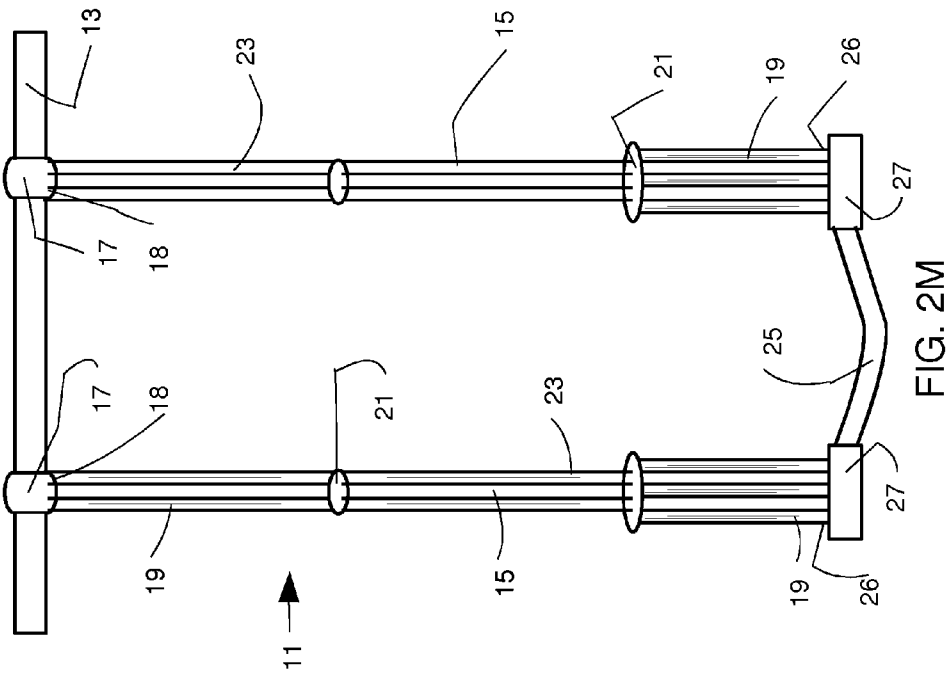

FIG. 2M

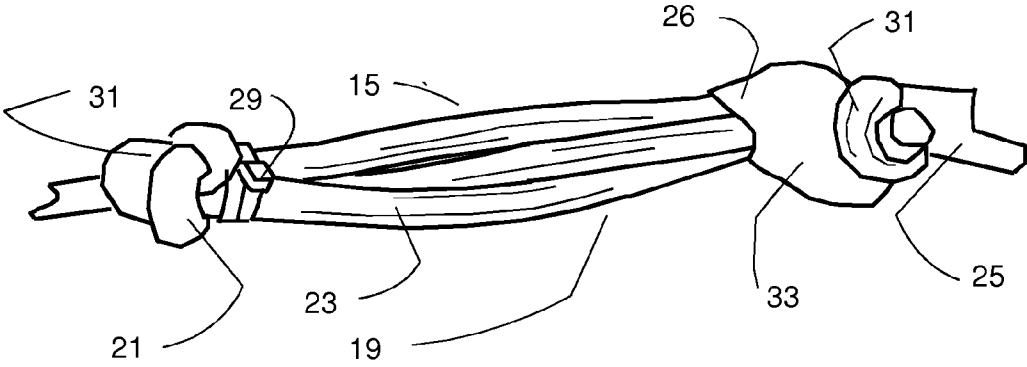

FIG. 3

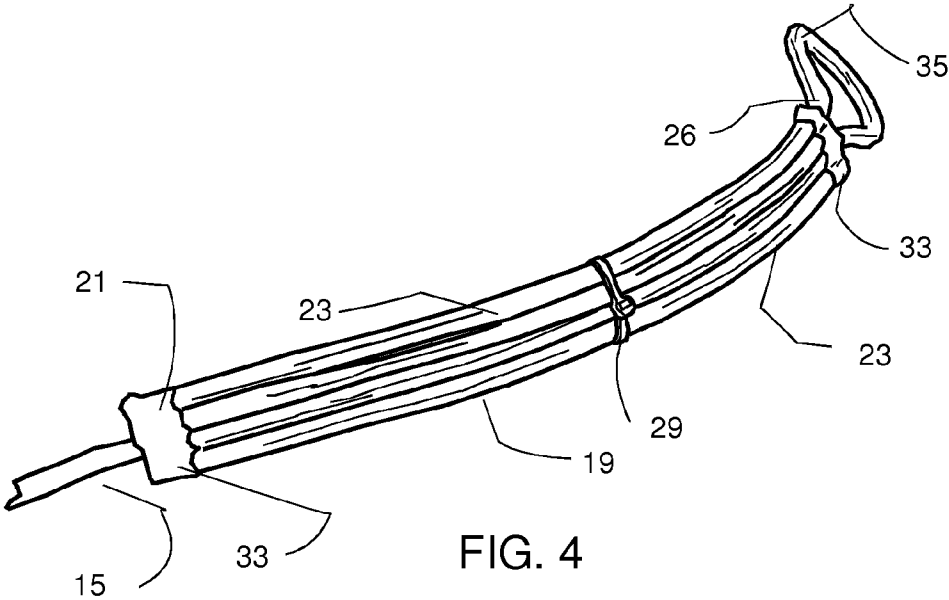

FIG. 4

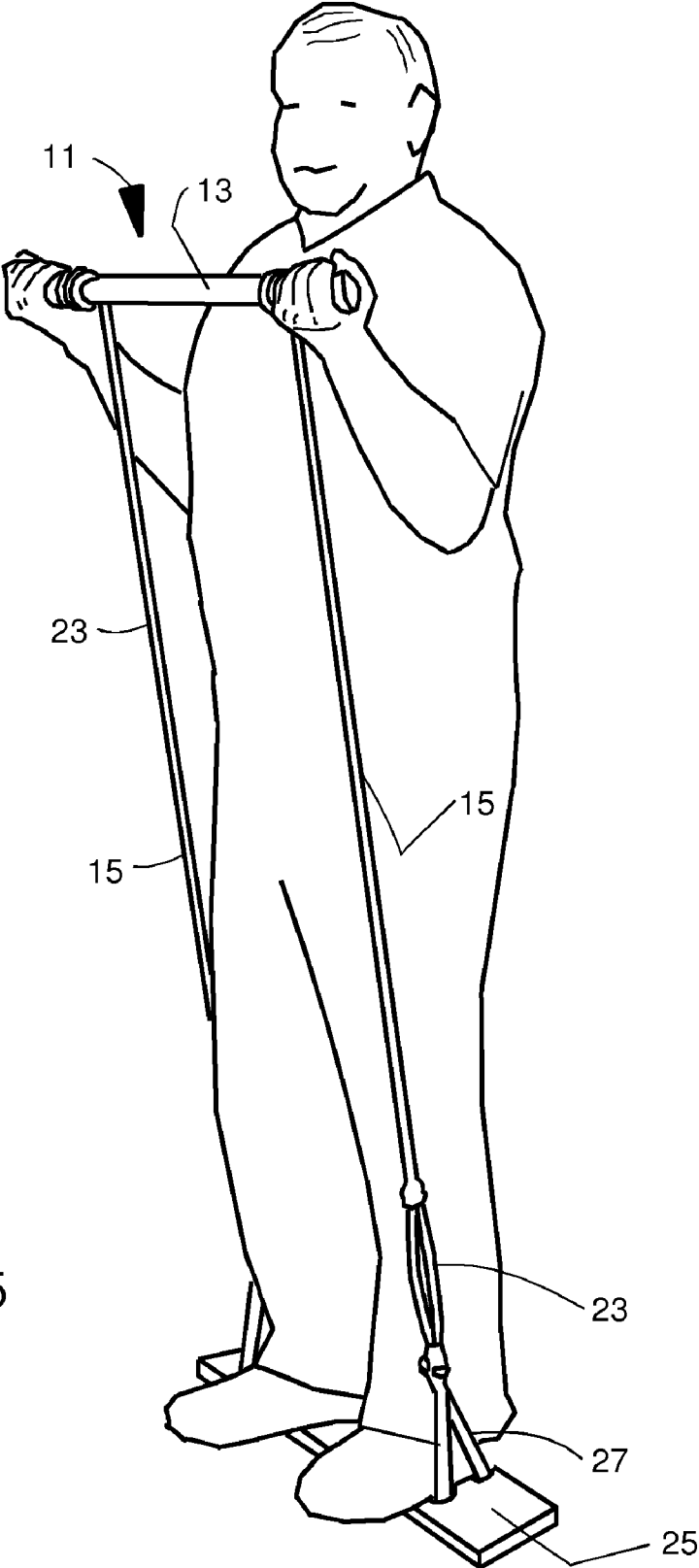

FIG. 5

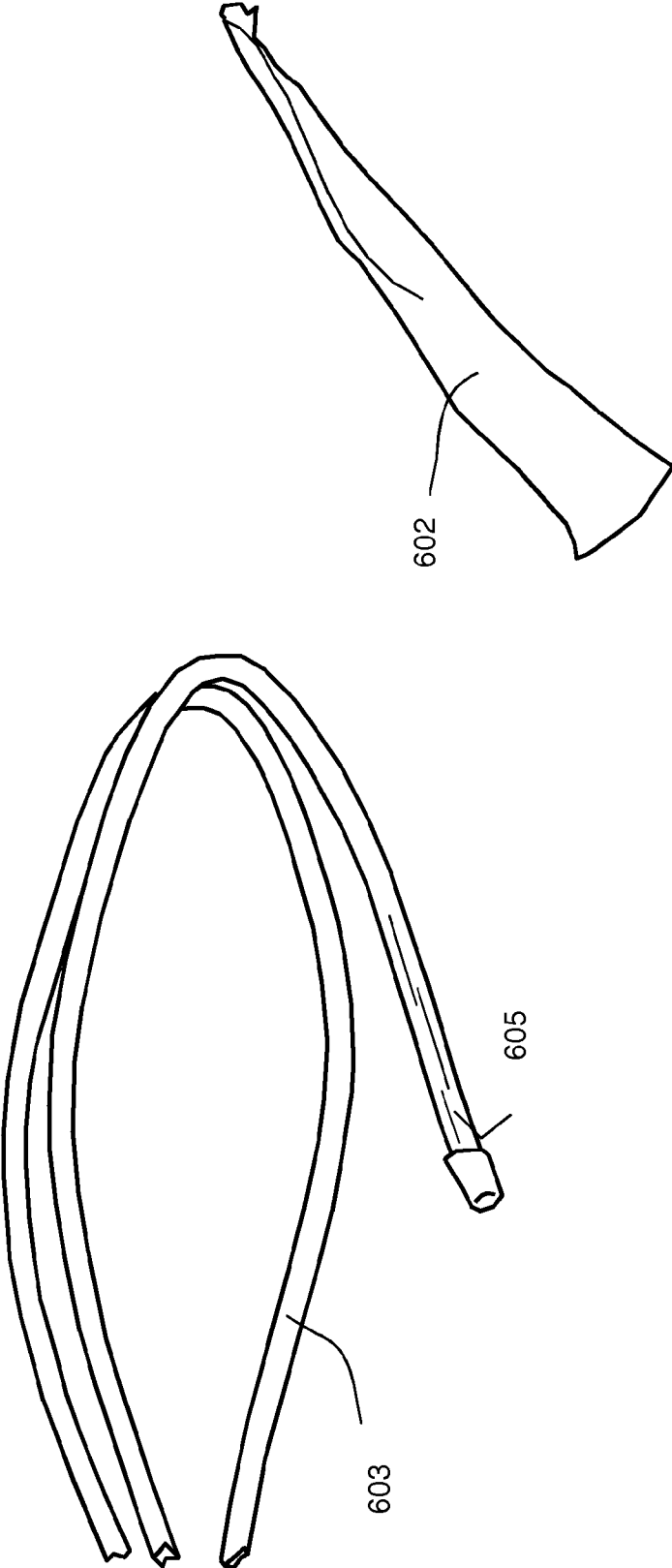

FIG. 6A

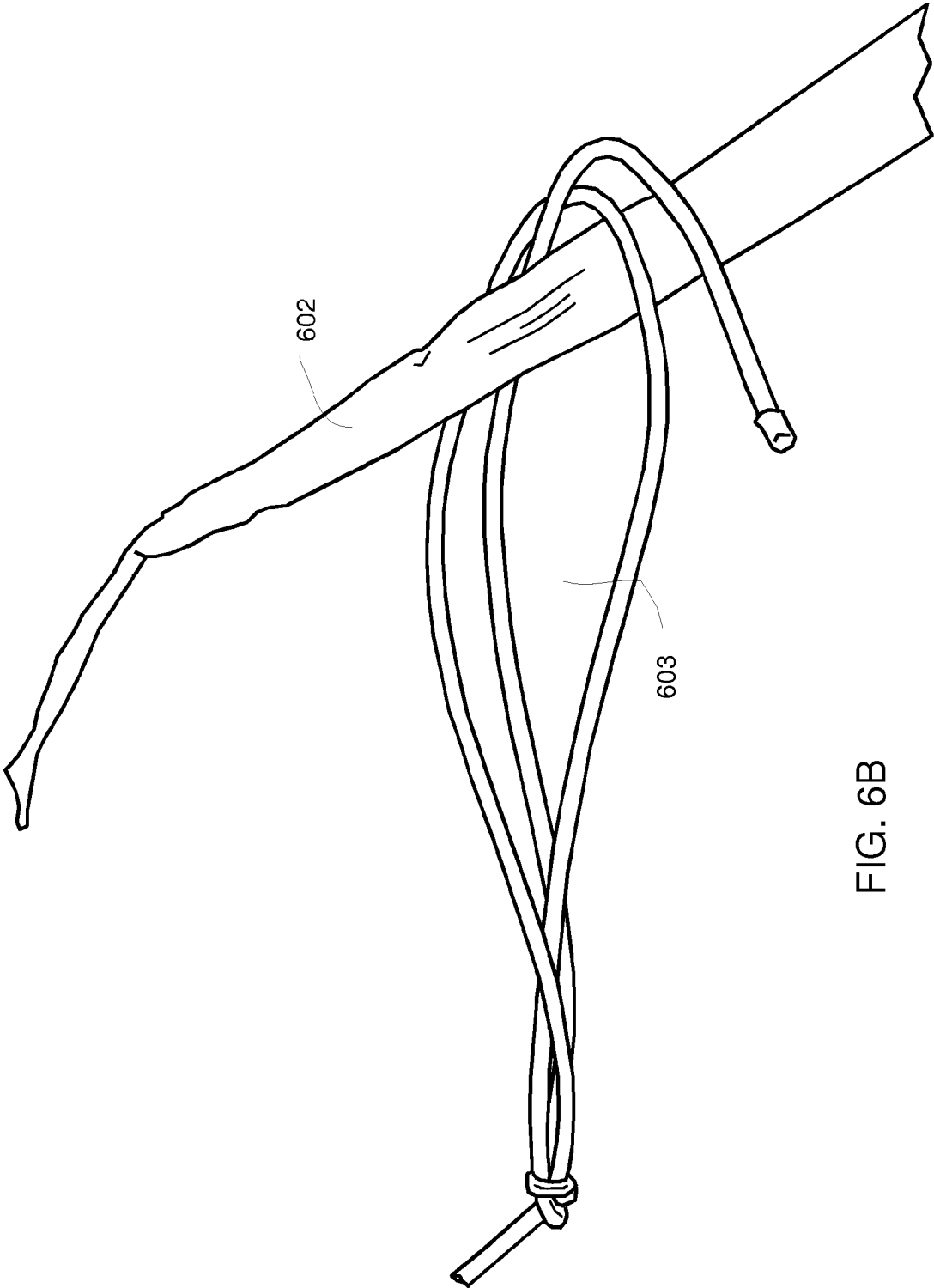

FIG. 6B

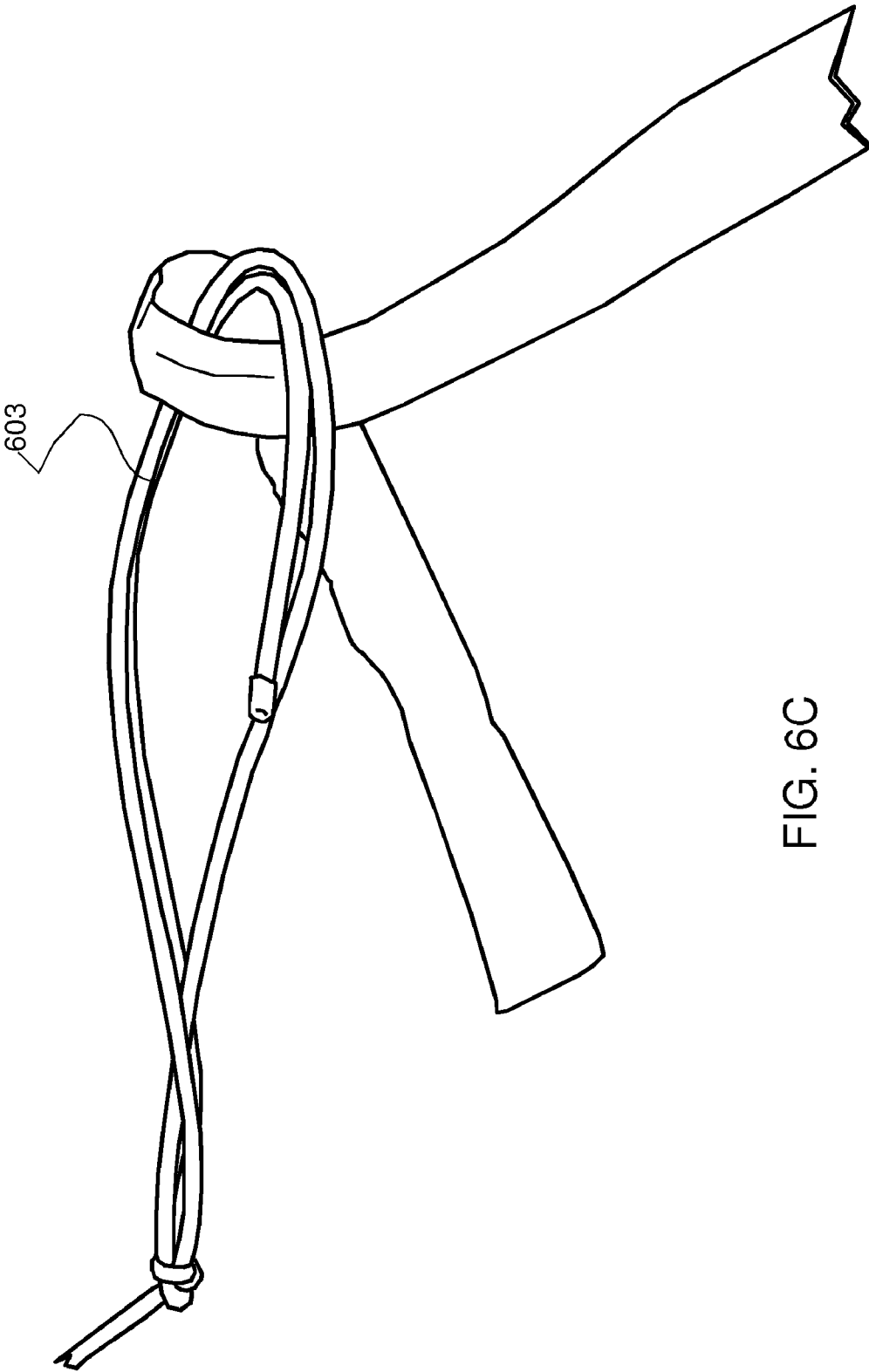

FIG. 6C

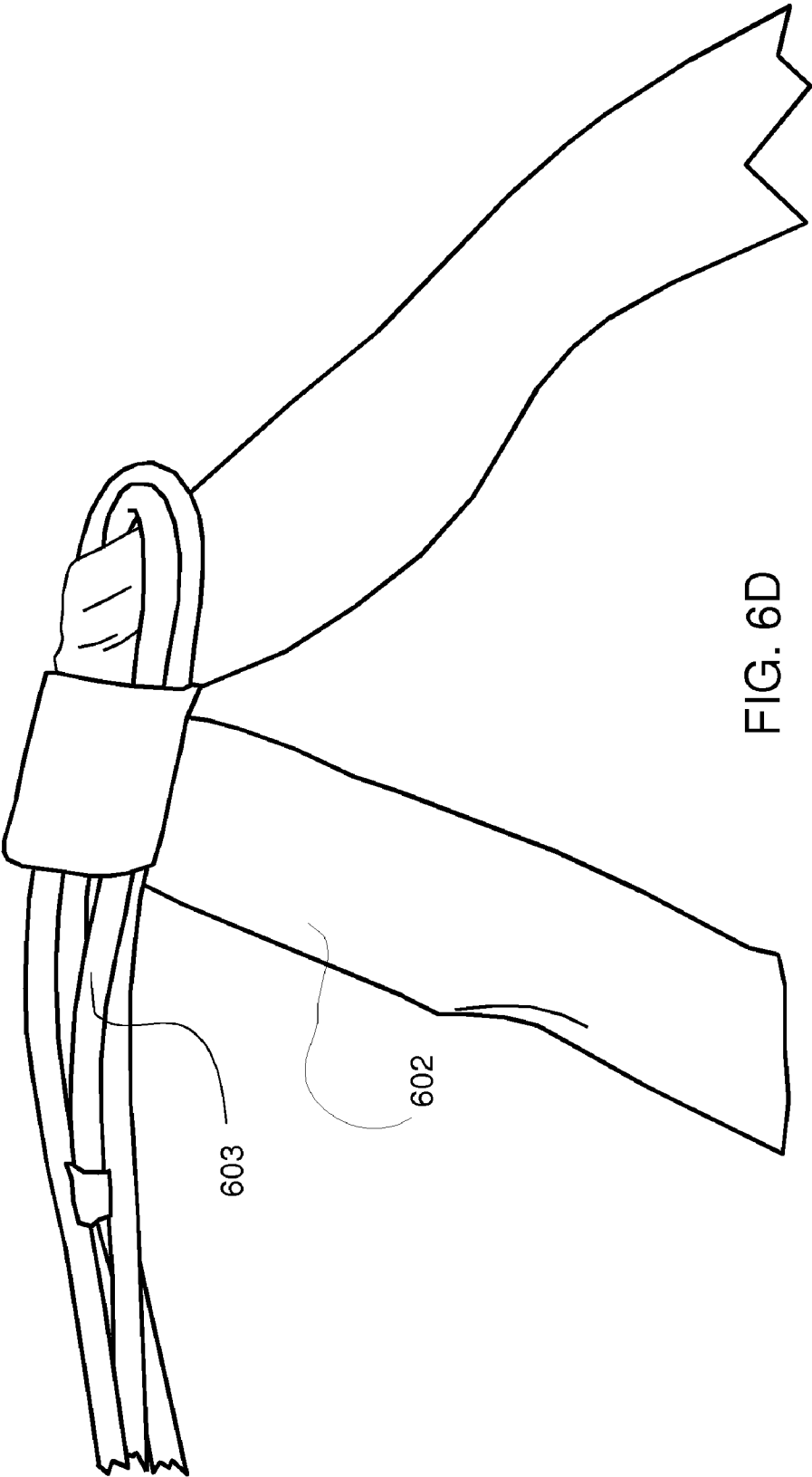

FIG. 6D

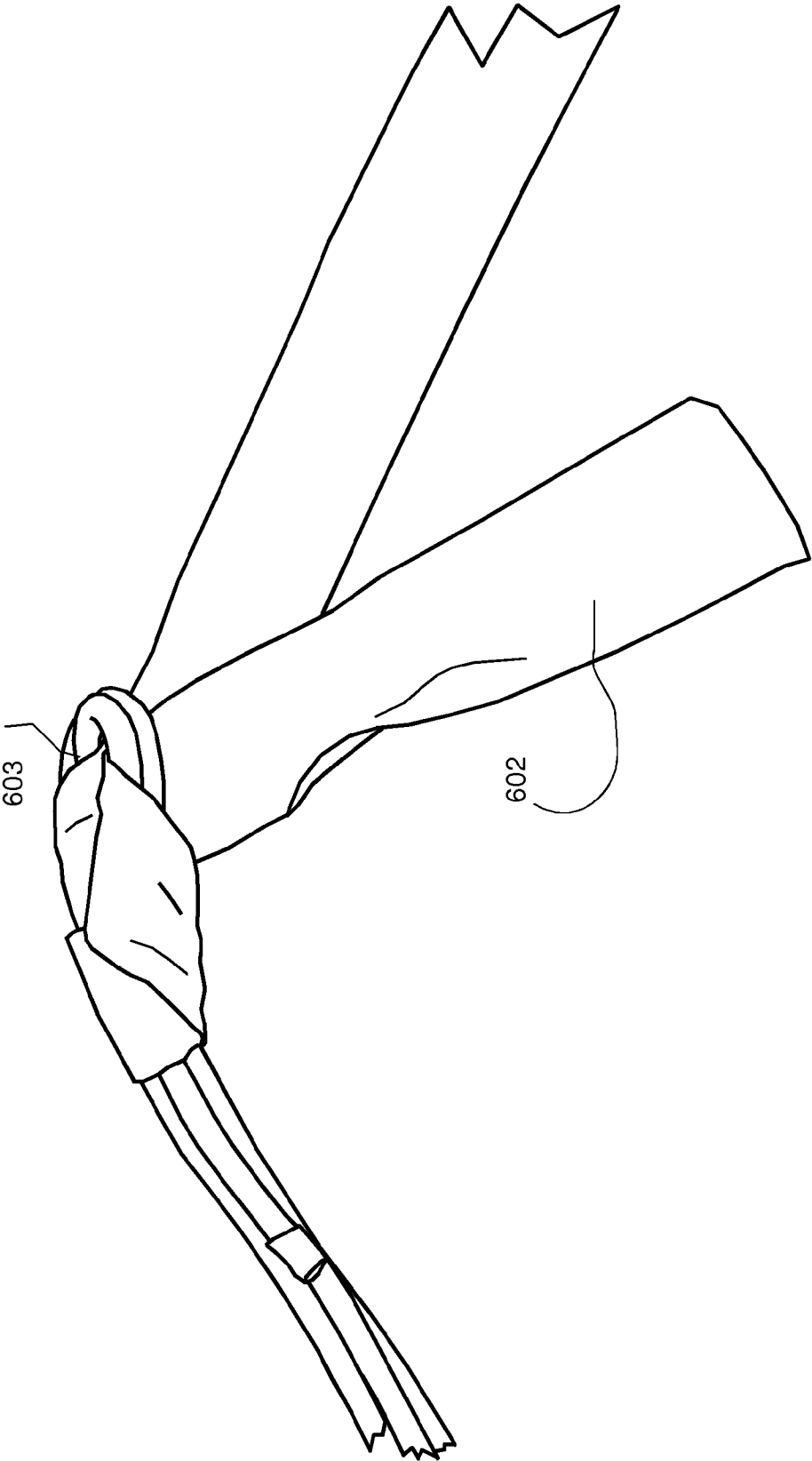

FIG. 6E

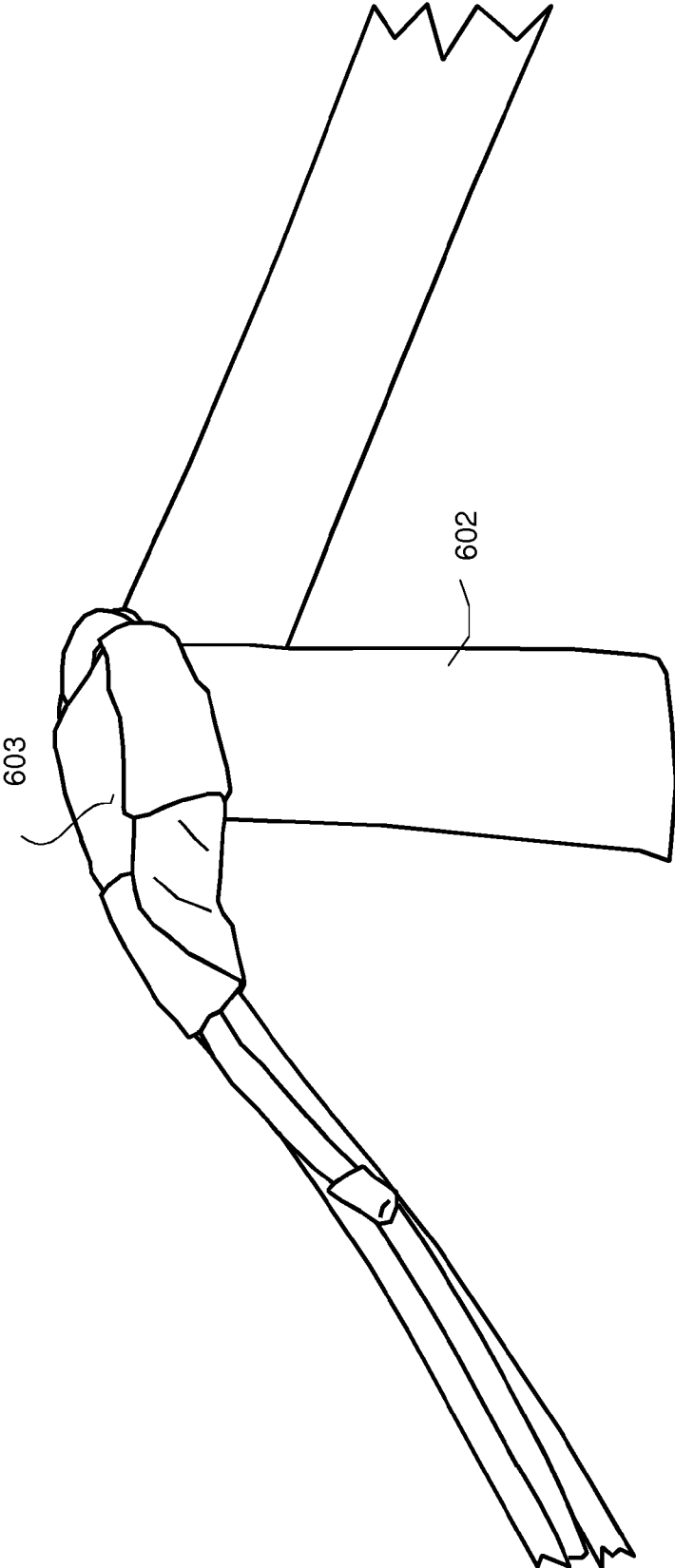

FIG. 6F

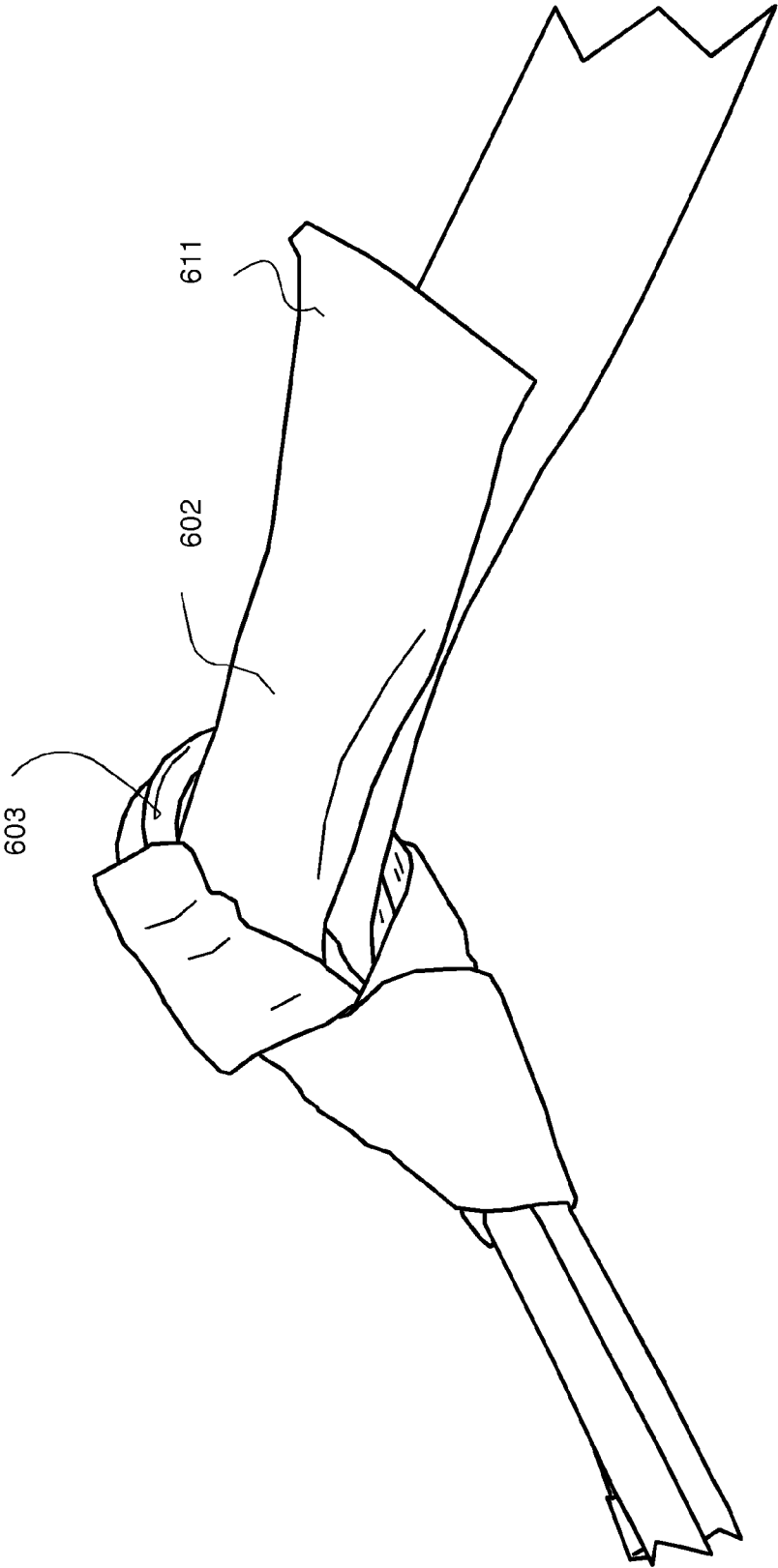

FIG. 6G

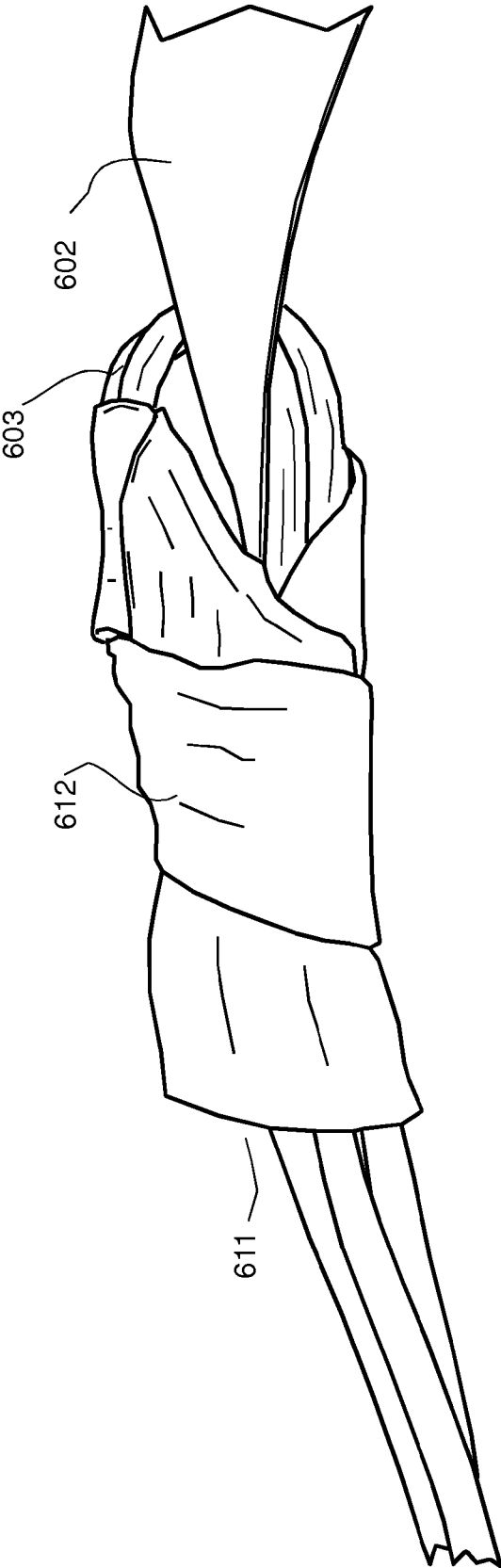

FIG. 6H



FIG. 6I

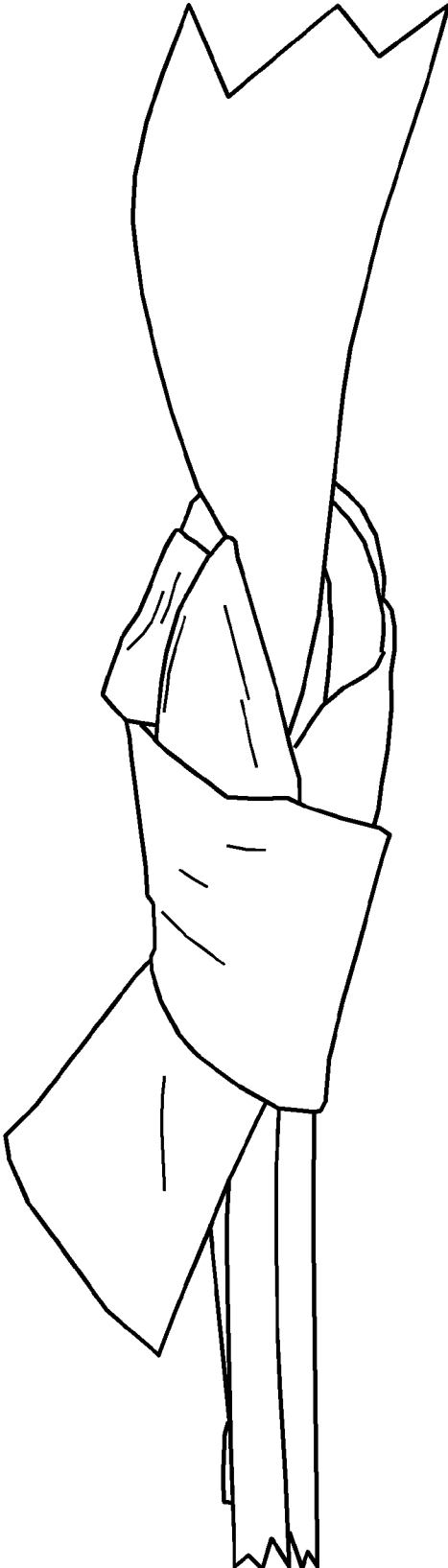

FIG. 6J

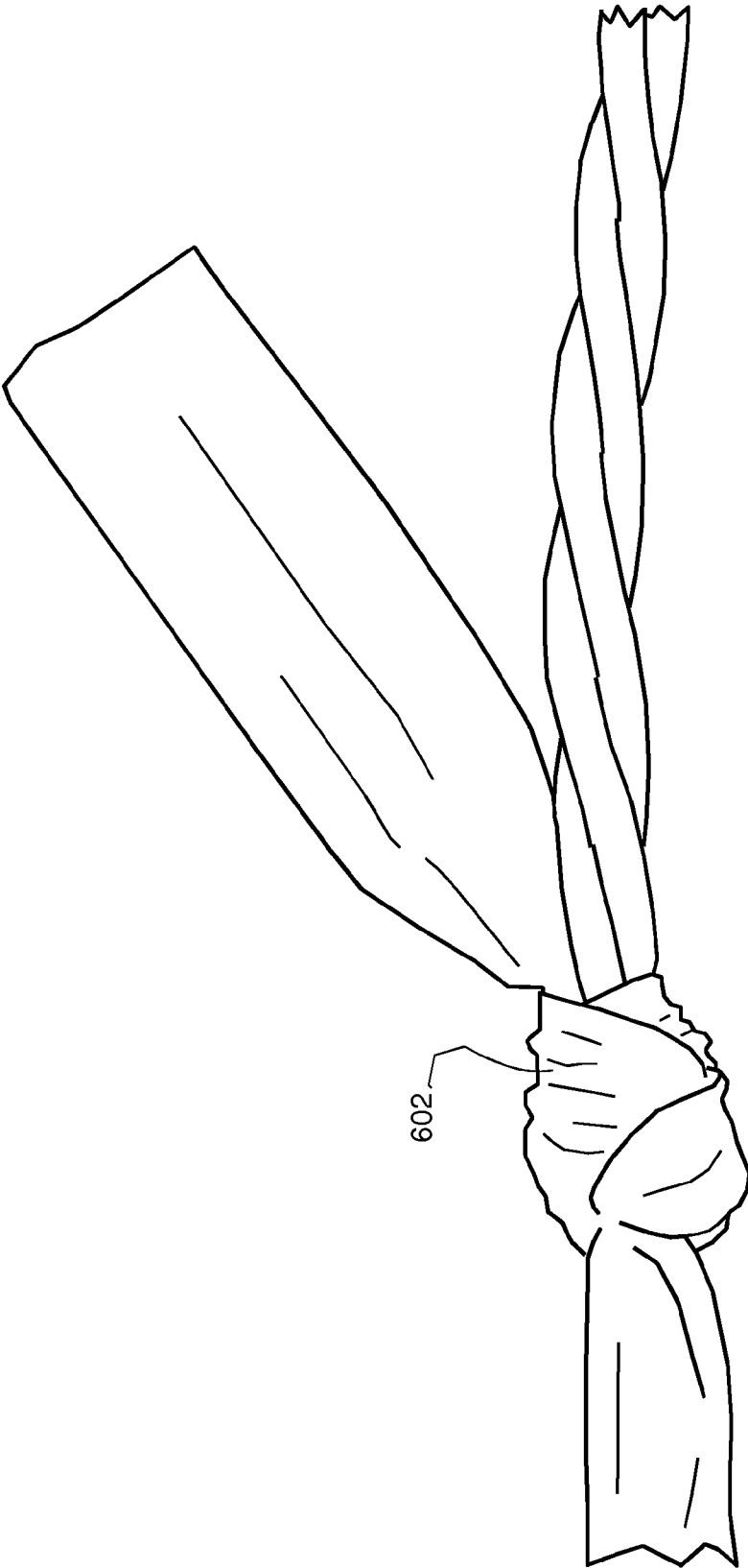

FIG. 6K

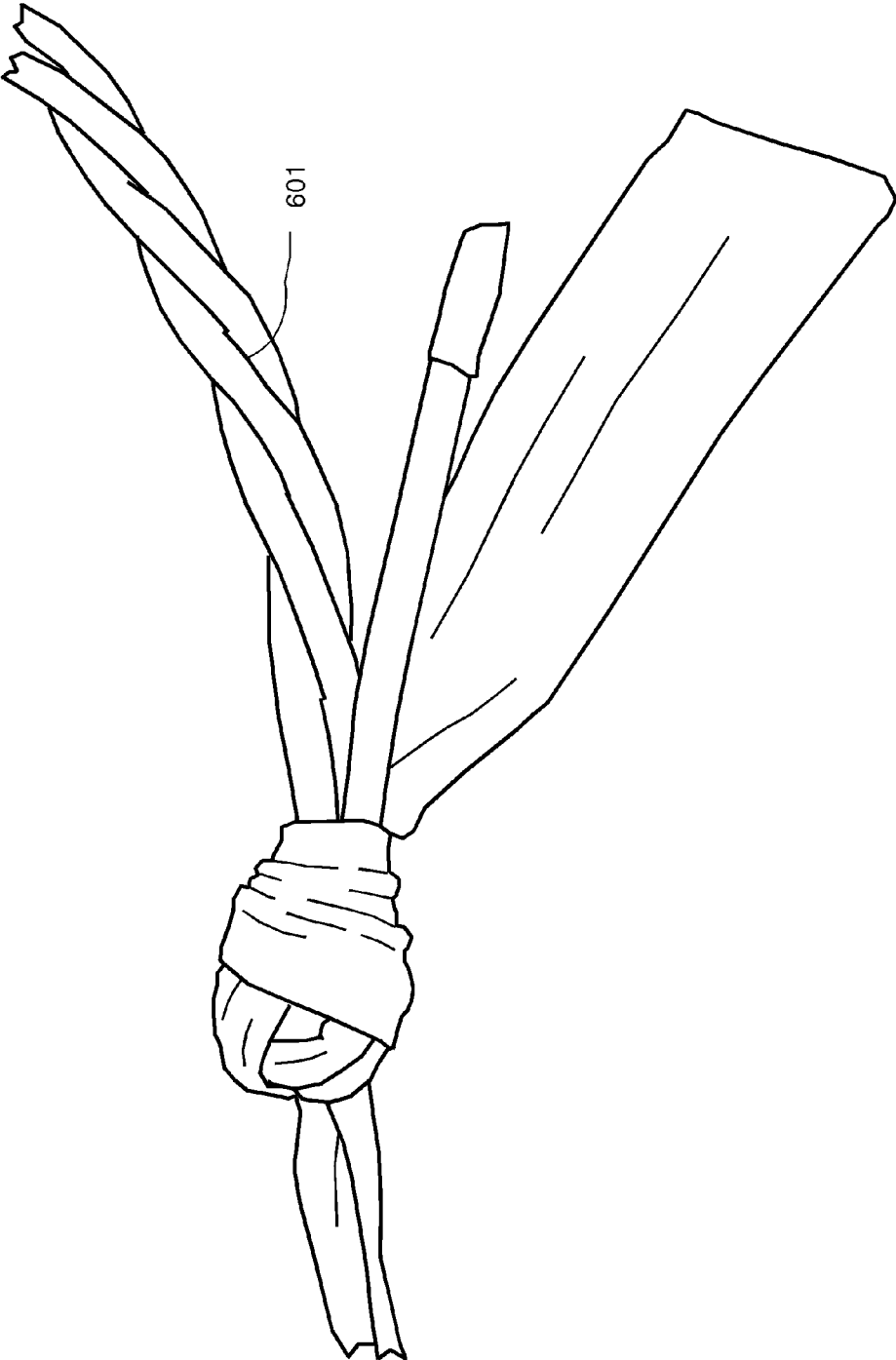

FIG. 6L

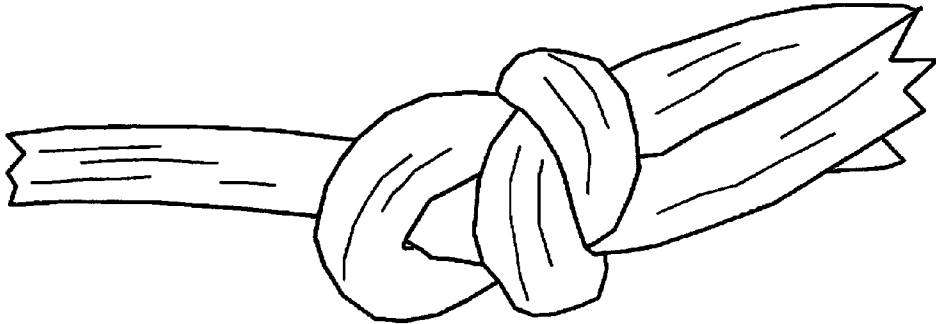

FIG. 7B

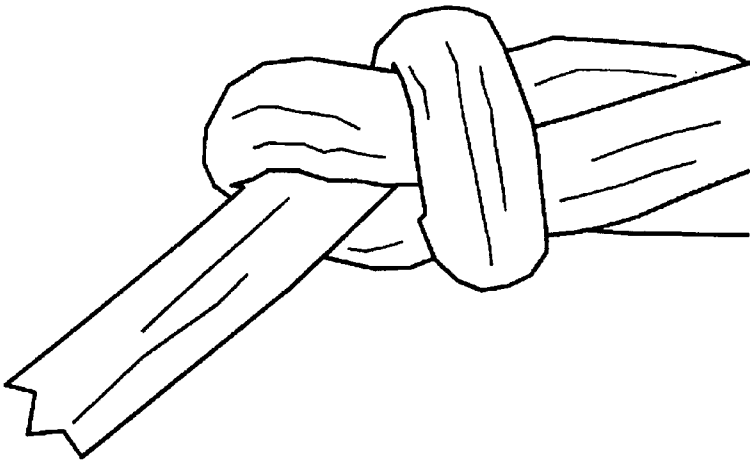

FIG. 7A

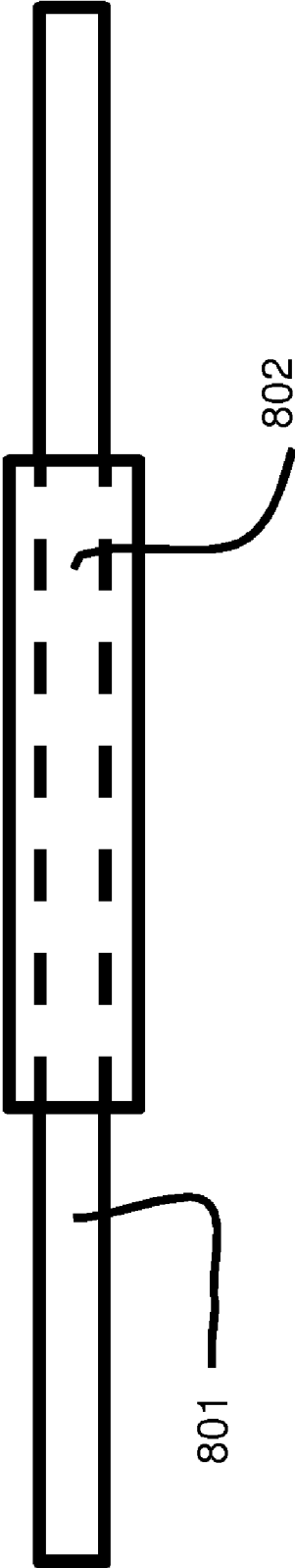

FIG. 8

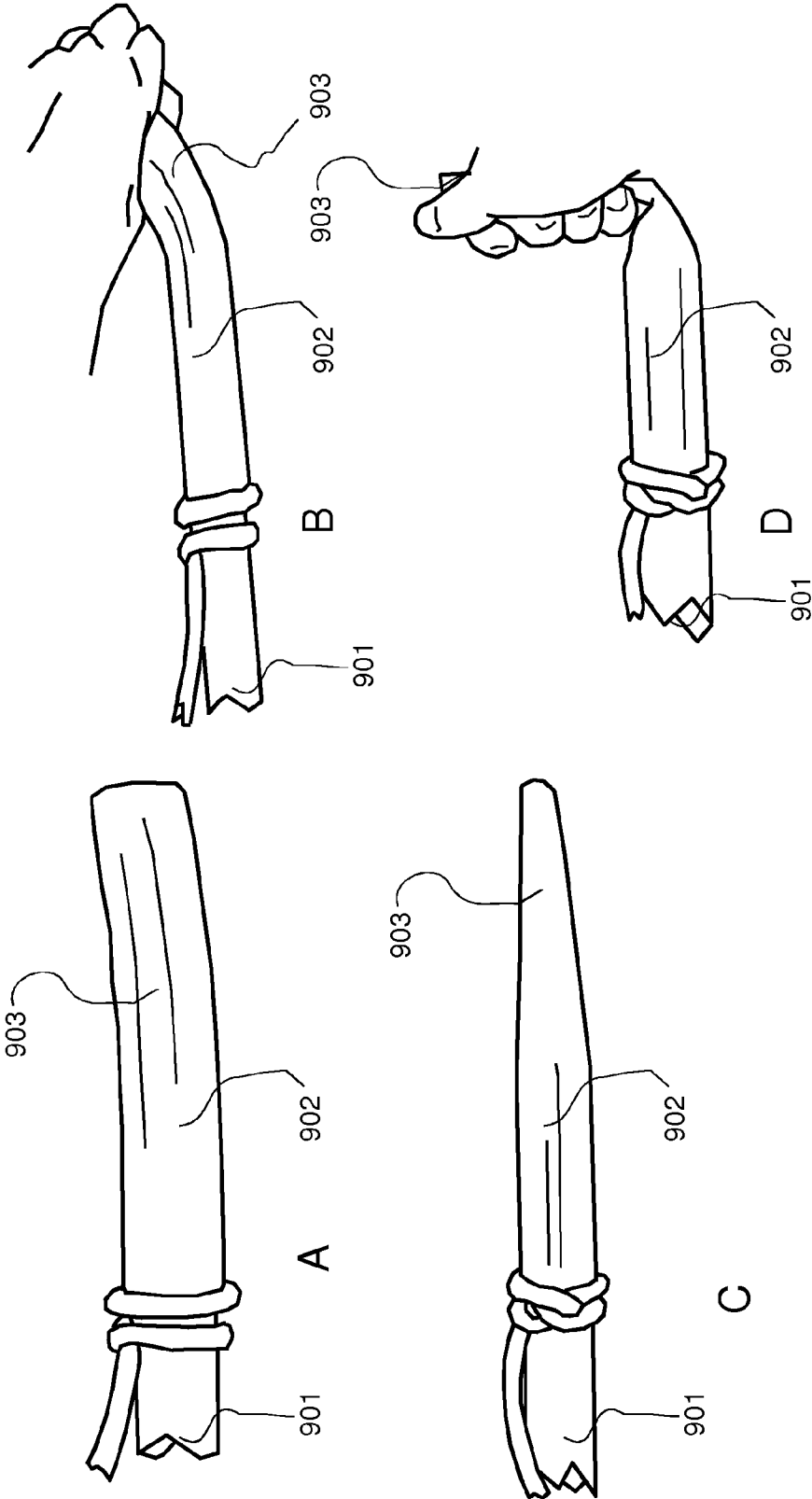

FIG. 9

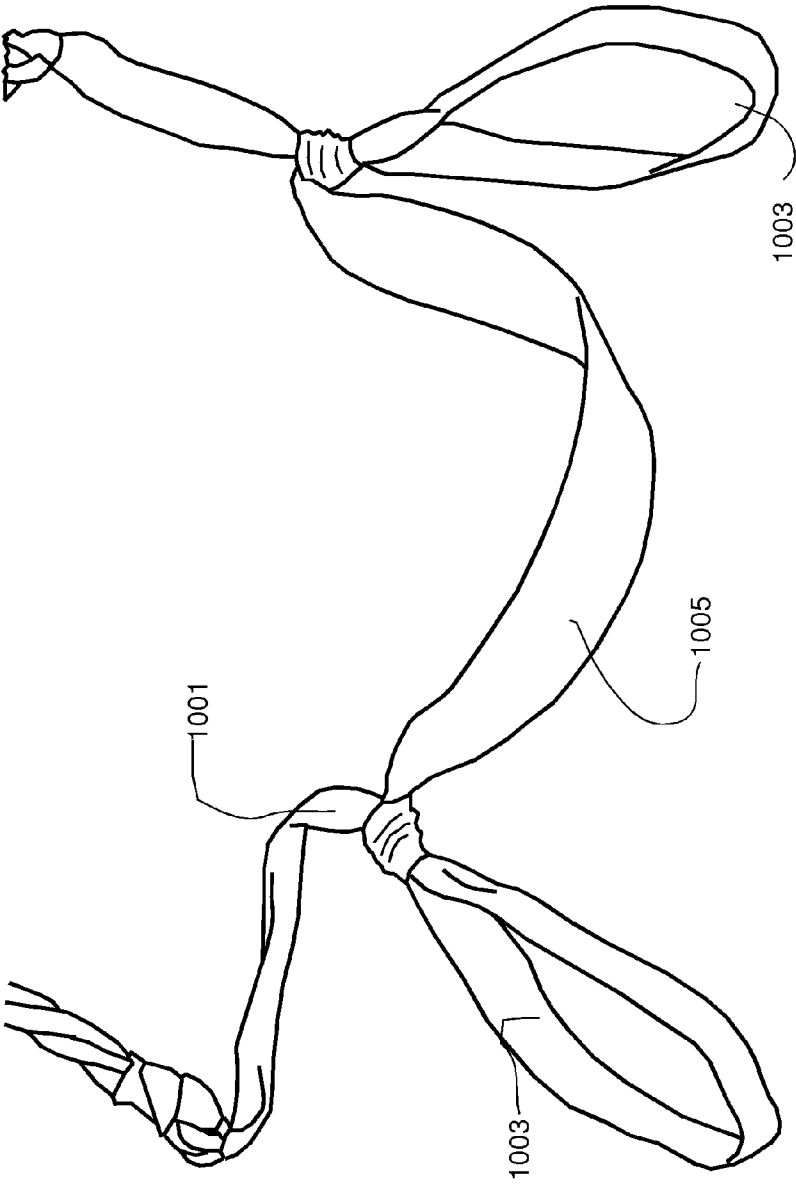

FIG. 10

EXERCISE AND FITNESS SYSTEM

CROSS REFERENCE TO RELATED APPLICATIONS

[0001] This is a continuation-in-part of U.S. patent application Ser. No. 11/450,114, filed 9 Jun. 2006, and a continuation of U.S. patent application Ser. No. 12/258,714, filed 27 Oct. 2008, which are hereby incorporated by reference.

BACKGROUND

[0002] The use of exercise machines has proliferated in the last decade or so. In general there are two main classifications of such machines—those primarily intended for use in a commercial sports center and those primarily intended for use in the home. Those intended primarily for use in a sports center are quite complex, are structurally heavy and bulky, are usually attached to the floor or the wall, and oftentimes have a complicated arrangement of levers, pulleys, weights, etc. Normally they may also be adjustable for different users having different physical strengths. Those intended primarily for the home are simpler, lighter, much less expensive but still adjustable to some degree.

[0003] One such exercise machine comprises flexible elastic shock cords, usually two, which are stretched by a force exerted by the user. As a cord is stretched more and more, the force required to stretch it increases more and more. One end of the shock cord is attached to a fixed structure and the other end attached to a booster bar adapted to be moved by the user's arms or legs as the cord is stretched by the user. As a natural consequence of the size of the user the stretched length of the shock cord will be substantially constant for a given user but will be different for a different user. Also as a natural consequence of the physical characteristics of shock cords the force-length curve is an inverse exponential when the force is displayed as the abscissa. Thus the maximum force required for a given user to stretch his arms or his legs to their fullest extent depends on the characteristics of the shock cord and also on the ratio of the stretched length to the unstretched length of the shock cords. Since a different user having a different physical size or strength will require a different ratio of stretched length to unstretched length it becomes necessary to provide some means for shortening or lengthening the unstretched length. This is normally effected by means of clamps; however the clamps oftentimes damage the shock cord and thus make the shock cord essentially unusable after a given number of adjustments.

[0004] In U.S. Pat. No. 5,125,649, to Conrad Fuller (Fuller) (incorporated hereby by reference) is an exercise machine with a booster bar that mitigates the problems of adjustment found in previous systems, where the stretched and unstretched length of the shock cord are adjusted by the user without the use of clamps or tools. In the Fuller system a booster bar is attached to pair of flexible elastic shock cords, which have their other ends attached to fixed structural members. The user exercises his arms or his legs by repeatedly pushing against the booster bar, thus stretching and unstretching the shock cords. The unstretched (and thus the stretched) length of the shock cords is adjusted by rotating the booster bar about its axis, thus winding or unwinding, the shock cords around the booster bar. This, in turn, adjusts the force required to stretch the shock cords to a given dimension.

[0005] However, the Fuller system is still not adequate in providing an exercise machine that can be used by different

users of different size and with different strengths. This is due to the nonlinear force-length properties of braided shock cords, which as mentioned in the Fuller patent can be represented as an inverse exponential curve. Basically as the cord is stretched, the stretching or return force is approximately constant or increases proportionally at a modest rate. But, as the maximum stretching length for the cord is approached, the return force increases much more rapidly, where (at least as perceived by the user) even significant increases in the force will not cause the cord to stretch further. Thus, the perceived effect by the exerciser is a movement that is suddenly or abruptly stopped. In other words, as the cord is stretched, the user at first perceives a constant or modest increase in force as determined by the stiffness of cord until a point is reached where the stretching or return force increases rapidly with no or little increase in the stretching length. At this point the exerciser perceives an abrupt stop and cannot continue extending the cord.

[0006] Basically, a braided shock cord will extend, depending on the particular cord construction, up to 100% or more of its unstretched length, until it reaches a this "abrupt stop" point where under higher and higher forces it will stretch only a small amount.

[0007] As described in the Fuller patent, the length of the shock cords can be adjusted by wrapping them around the booster bar. However, when fully unwound to lengthen stretching cord and allow the user to stretch the cords a greater distance before reaching the abrupt stop, the initial force and the force over the most of the length of the stretching is also reduced, which reduces the exercise effect. To increase the force and the exercise effect, the stretched length of the shock cord can be shortened by wrapping the cord around the booster bar. But if the stretching length is shortened too much this will prevent the user from extending the cord to the length required for the exercise. This is because the user is attempting to stretch the shortened shock cord beyond its design and the "abrupt stop" is encountered before the exercise movement is completed.

[0008] A partial solution is to use shock cords of different elastic, i.e., stiffness, properties. "Stiffness" or "stiff" is a measure of the amount of elastic return force obtained for a given amount of stretching. For a strong person, a machine with stiffer cords is chosen so that the stretching force is high at the beginning during the stretch. Because the cord does not have to be shortened excessively, and the abrupt stop isn't reached during exercise movements, the person is allowed to stretch to the desired length for the exercise. A weak person could not use such a machine, because, even when the cords are fully unwound to the full length, the stretching force is too high, and he would only be able to successfully accomplish few or none of the exercises. For the weak person, a machine with less stiff or compliant shock cords would be suitable. However, the strong person would not find this machine suitable, because she would be able to extend the cords as far as she can extend her limbs without feeling adequate increase in the stretching force. Winding the cords around the booster bar to increase the force, may result in insufficient stretching length where the abrupt stop will likely be reached during routine exercises. Exercises with long stretches then become difficult or impossible.

[0009] In summary, the Fuller machine has the ability to change the stretching length of the shock cord, which enables a person to vary the stretching force and to do a variety of exercises, from short stretches to long stretches. But, the

advantage is not fully met if the stiffness of the shock cords does not well match with a user's size and strength. This is a particular problem as the user becomes stronger over time, requiring the user to obtain a new machine or rebuild the old one.

SUMMARY

[0010] An aspect of the present system is an exercise apparatus comprising a rigid booster bar with two flexible elastic elements attached to the booster with an attachment. The attachments are spaced from each other and configured to allow winding the elastic element upon the booster bar by rotating the booster bar. Each flexible elastic element comprises at least two stages of flexible shock cords, with the stages disposed serially along the length of the flexible element, with adjacent stages having a different elastic stiffness.

[0011] Another aspect of the present system is an apparatus that improves upon the Fuller machine by extending the range of user size and strength that can be matched to a particular apparatus. Any one apparatus is optimal for a wider range of user size and strength. The apparatus of the present system can be used like the Fuller machine, by stretching and unstretching flexible elastic elements by means of a booster bar, and the user can change the stretching length of the elastic elements by wrapping same upon the booster bar. However, the present apparatus has replaced the shock cords in Fuller machine with improved flexible elastic elements that have a more optimum force-length curve. In addition, the apparatus of the present system, because of its unique construction, can be used in different ways.

[0012] The improved elastic elements can be wound and unwound upon the booster bar to adjust force, but with a small or minimal amount of winding required to obtain a higher stretching force. This leaves a larger stretching length and lessens the probability that the abrupt stop will be reached during an exercise movement. The cord can be stretched to high stretching forces without encountering an abrupt stop, even in exercises requiring high force and a long stretch.

[0013] Not only is the abrupt stop essentially eliminated, but the force-length profile is improved. During a stretch, higher forces are obtained at a slower rate. In addition, the stretching force encountered in an exercise movement is over a wider range, allowing a user to start the stretch at a lower force and stretch up to and sustain a higher force, a force that cannot be sustained if the high force comes on quickly or abruptly. This allows a user to sustain higher forces and gain more strength building benefit than in previous devices. In previous devices, one could not gradually obtain a high stretching force when starting a low stretching force, because the abrupt stop would be reached before the high force was obtained.

[0014] In addition, for any given apparatus a stronger user will be able to derive more exercise and obtain and sustain higher forces, and a weaker user has lower forces available that allows accomplishment of more exercises. Both weaker and stronger users benefit from the better force-length profile. Thus, it is possible by practice of the present system that a single apparatus can be provided that better meets the needs of a person as he grows stronger, and be more easily adjusted for wider variety of people, including children, adults, athletes, sedentary persons, and persons with physical disabilities.

[0015] The apparatus of the present system achieves the above advantages in part by having a rigid booster bar with a

flexible elastic element constructed with multiple stages of braided elastic stretch cords attached to each end. By "staged", is meant that the length of each stretch cord is subdivided into at least two regions or stages. Each stage is constructed with one or more braided shock cords, such that each adjacent region has a different stiffness from its neighboring or adjacent stages. Thus the stages are attached in series end to end such that the stiffness of the elastic element changes from stage to stage. This contrasts with the Fuller machine where the elastic cords are designed with essentially the same stiffness for their entire length.

[0016] Because the flexible elastic element is staged, with high stretch force a high elongation can be obtained without encountering an abrupt stop. This is in part to the fact that the large stretching forces can be obtained with a minimum of wrapping around the bar, allowing more of the length of the elastic element to be stretched.

[0017] In addition, as the flexible element is stretched, the lengthening or elongation is not distributed evenly along its length. During a stretch all of the stages will begin to elongate, but the less stiff stages will initially stretch more than the stiffer stages. As the less stiff stages approach their maximum elongation, more elongation will then occur in stiffer stages. Thus, elongation is serially transferred from the less stiff stages to the stiffer stages, with the stiffest stages being the last to sustain significant elongation. The stiffest stage is designed to sustain the maximum design force of the equipment without reaching its maximum elongation required for exercise. Thus, at any elongation during exercise, there are always one or more stages that have not reached maximum elongation, thus eliminating an abrupt stop.

[0018] Furthermore, at the beginning of the stretch the force is mostly determined by the least stiff or most compliant stage, but the elastic element can be stretched to a high final force as determined by the stiffest stage. By the staged system a rather even force profile can be provided that extends from a low stretching force of stiffness to a stiffness, and this profile can be predetermined by the selection of different stiffnesses of multiple stages.

BRIEF DESCRIPTION OF DRAWINGS

[0019] FIG. 1 is a perspective drawing of an exemplary exercise apparatus.

[0020] FIG. 2A to FIG. 2N are schematic drawings illustrating various configuration of an exercise apparatus.

[0021] FIG. 3 is a drawing of part of an elastic element of an exercise apparatus.

[0022] FIG. 4 is another drawing of part of an elastic element of an exercise apparatus.

[0023] FIG. 5 is a perspective drawing of an exercise apparatus in use.

[0024] FIG. 6A to FIG. 6L illustrate a knot fastener used in fabricating a device.

[0025] FIGS. 7A and 7B illustrates an attachment for stages.

[0026] FIG. 8 illustrates a padded booster bar.

[0027] FIG. 9A to 9D illustrate a leveraged handle configuration.

[0028] FIG. 10 illustrates a strap with a three-way support.

DETAILED DESCRIPTION

[0029] Reference is now made to FIG. 1, and FIGS. 2A to 2N. The apparatus 11 comprises a booster bar 13 with two

elastic element **15** attached to the booster bar **13** by an attachment **17**. Each elastic element comprises two or more stages **19**, with at least two adjacent stages having a different stiffness.

[0030] The stages are constructed of braided elastic cords **23**, also known as “shock cords”, or “bungee cords”

[0031] A characteristic of shock cords is their nonlinear stretching behavior. This nonlinear behavior combined with the staged construction provides a modified force vs. extension curve that advantageously eliminates the abrupt stop problem associated with the non-staged Fuller and like systems. This can be explained by reference to Hooke’s law. Hooke’s law can be represented by the equations:

$$x = -f/k$$

where “x” is the distance that the spring has been stretched or compressed away from the equilibrium position, which is the position where the spring would naturally come to rest, “f” is the restoring force exerted by the material, and “k” is the force constant. When Hooke’s Law applies in a system the behavior of the system is described as linear. If two springs (stages) are used in serial, and both of the springs follow Hooke’s law, together they behave like one spring having a different constant equivalent to the two combined, represented as $k_{eg} = 1/(1/k_1 + 1/k_2)$. Thus, it can be seen that if elastic materials are linear, there is no advantage to using multiple stages of different stiffness, because such merely function the same as a single stage spring with an equivalent constant.

[0032] However, if the elastic material is non-linear, which is the property of flexible shock cords used in the invention, use of two stages results in a different behavior. As described above, flexible shock cords are non-linear with a rapid increase in force as they approach a stretching limit, which causes the “abrupt stop”. Linear materials do not have such a stretching limit or an “abrupt stop”—they just increase in tension in a linear manner, and will stretch more proportionally as more force is applied. In flexible shock cords, the restoring force increase is non-linearly so that as the stretching limit is approached there is a disproportionate and rapid increase in the restoring force.

[0033] In the staged construction of the present system, as the stretching limit of one stage is approached the restoring force is not suddenly increased, because as the stretching limit of a stage is approached the stretching is taken up by another stage which has not reached its stretching limit. This behavior of successive stages successively taking up the stretch only provides any advantage and only occurs with non-linear (non-Hooke’s Law) elastic materials like flexible shock cords.

[0034] Shock cords are available with an inner core of an elastomer, such as latex, with a covering such as a braided sheath. Shock cords are widely available in various diameters and stiffness. Any diameter can be used. Diameters between ¼ and ½ inches have been found suitable.

[0035] A stage may comprise one shock cord or multiple shock cords attached together in parallel. Multiple shock cords in a stage may be of the same stiffness and diameter or different stiffness and diameter. In addition, the thickness and diameter of shock cords in the different stages may be the same or different.

[0036] A requirement is that the elastic element comprise at least two adjacent stages that have a different stiffness. The varying stiffness of the stages can be provided by changing the number of shock cords in the stages. Thus, for example, a

first stage may comprise one shock cord, a second stage or two shock cords, and third stage or three shock cords. The stage may be in any order. It is preferred that the stage with fewer shock cords be adjacent to the booster bar to ease the wrapping of the elastic element around the bar easier. However, putting stiffer stages adjacent the booster bar is also contemplated. In the table below is shown various illustrative combinations, showing the number of shock cord strands in each stage, with the first being at the near end **18** nearest to the booster bar. Also in the Table, there are references to Figures illustrating that particular combination.

[0037] The stiffness can also be changed by changing the stiffness of the cords used in the stages. Thus, for example, a two-stage flexible element can be constructed with ¼ in. cord in stage **1**, and ½ inch cord in stage two. Referring to FIG. **2G** and FIG. **2H** are shown flexible elements, each with a thicker or stiffer cord (e.g. ½ in) continuing through all stages, with a less stiff or thinner cords (e.g. ¼ in) in stages **2** and **3**. FIG. **2G** shows one thinner and one thicker in stage **2**, while FIG. **2H** shows two thinner and a thicker cord in stage two. In stage three are respectively two thinner and one thicker in FIG. **2G**, and one thinner and two thicker in FIG. **2H**.

TABLE

| No. of Stages | No. of Shock Parallel Cords in Respective Stages (Bold Nos. represent stiffer cords) | FIG. where illustrated. |
|---------------|--|-------------------------|
| 3 | 1-3-4 | FIG. 1 |
| 5 | 1-2-4-6-7 | Not Shown |
| 4 | 2-1-2-3 | Not Shown |
| 2 | 1-3 | FIG. 2A |
| 2 | 1-2 | FIG. 2B |
| 3 | 1-2-3 | FIG. 2C |
| 3 | 1-3-5 | FIG. 2D |
| 3 | 1-2-3 | FIG. 2E |
| 3 | 2-3-4 | FIG. 2F |
| 3 | 1-(1,1)-(2, 1) | FIG. 2G |
| 3 | 1-(2, 1)-(1, 2) | FIG. 2H |
| 4 | 1-2-4-6 | FIG. 2I |
| 3 | 3-1-5 | FIG. 2J |
| 3 | 2-1-3 | FIG. 2K |
| 3 | 1-3-1 | FIG. 2L |
| 5 | 1-3-5-3-1 | Not Shown |
| 3 | 2-2-3 | FIG. 2M |
| 3 | 1-1-1 | FIG. 2N |

[0038] There must be at least two stages having different stiffness in an elastic element. The more stages, the more even will be force-length profile, but the number of stages is limited by practical construction limitations. More stages may be recommended where there is a large difference between the number of cords between the most compliant and the stiffest stage. The length of the stages can be any suitable length. The stages may of the same length or one stage may be lengthened or shortened relative to the others.

[0039] Where there are three or more stages, stages may have the same or different stiffness as long as there are at least two stages that are adjacent and have different stiffness. Combined length of the stages, or the total length of an elastic element is consistent with the nature of the exercises to be performed, the size of the user and the construction of the moving or fixed attachment (e.g., the opposing member). For an exercise device as in FIG. **1**, a flexible elements of length around 4 feet are suitable.

[0040] The stages are attached to each other end to end in series by a suitable attachment system **21**. Methods for attach-

ing cords to one another at the ends of the stages can be any suitable method, and include any combination of: tying with knots, thermally fusing, gluing, molding together without or with separate elements, sewing, using crimped or other metal fasteners, wrapping or fixing material around the cords (e.g., wire ties, tape, string, shrink-wrap, wire). One or more shock cords can be continuous through adjacent stages. For example, a single cord may extend through all of the stages, or through two or more stages. (See FIGS. 2G and 2H).

[0041] FIG. 3 is a detail of an attachment 21 of stages of a flexible element and shows how cords 23 can be assembled into stages using knots 31 and polymeric wire ties 29. The figure also shows attachment 27 of the last stage or the distal end of the elastic element attached to an opposing member 25. In FIG. 3 the illustrated stage has three cords joined to a stage of one cord. One cord is continuous through both stages. The opposing member is a flexible web strap and is attached using knots 31 and tape wrapping 33.

[0042] FIG. 4 is another detail of a flexible element showing a stage of four cords 23 glued and bound with wrapping tape 33 at the joiner with an adjacent stage of one cord. Also note in FIG. 4 is a loop. The loop 35 can function as an opposing member, by, for example, attachment to a foot, or fixed object. The loop can also function as part of the attachment to an opposing member of any suitable configuration.

[0043] The attachment to the booster bar may be the same as in the Fuller machine. The attachment is preferably placed so that the elastic elements can be wound upon a region of the booster bar between the attachments, with handgrips outside of the attachments at the ends of bar, as illustrated in FIG. 1, and FIG. 5. It is preferred that the least stiff stage in the elastic element be at its near end 18, i.e., the end that is near to or attached to the booster bar. This is to ease the winding of the flexible element around the bar. However, any of the stiffer stages can be the first stage or the stage at the near end 18 that is attached to the booster bar, as long as such does not materially affect the function of the exercise apparatus. (See FIGS. 2J and 2K) In FIG. 5 are shown elastic elements 15 wrapped around the booster bar 13.

[0044] The near ends 18 of the elastic elements 15 are attached to the booster bar 13, by a fixed attachment 17 to permit winding, so that the stretched length of the elastic element can be adjusted by rotating the booster bar and thus winding cords of the stages around the booster bar to any degree desired. The attachment may also optionally include a length of nonstretching flexible cord between the cord and the booster bar.

[0045] Optionally, handgrips 37 (FIG. 1) are applied to the bar in an appropriate region for grasping the bar, such at the ends of the bar, or in a medial hand grip region. This is to assist the user in grasping and holding the bar, to ease holding and winding of the bar, and hinder rotation of the bar within the grasp while the elastic elements are stretched. The grips may be any suitable materials, such as sections of hoses of suitable diameter, shrink wrap polymers, rubber applied by stretching or dipping, wrapped plastic or cloth tape, and the like. However, it is also contemplated that only a bare booster bar be used in apparatuses where adequate gripping force can be applied by the bare hands or with gloves.

[0046] The booster bar may be any suitable bar-like structure of suitable strength and dimension that functions as described. The bar may be solid or tubular, and may be of metal (aluminum, steel, titanium, etc.) wood, polymeric materials (fiber reinforced polymers, engineering plastics,

etc.) or any other suitable material. The bar may be a single unit, assembled from separate parts, or may be constructed to allow disassembly into smaller parts for transport. This may be by means of telescoping tubes or the like. The cross-section is circular, or non-circular (oval, polygonal, polyhedral with rounded edges, ridged, knurled, etc.), but sufficiently round to allow winding of the elastic members around the booster bar.

[0047] A distal end 26 of each flexible element is configured for a moving or fixed attachment 27 to an opposing member 25 to allow stretching of the flexible element 15. The structure and placement of the opposing member and of booster bar are such to work the elastic elements while performing an exercise movement. The opposing member for an exercise can be placed, for example, under one or both feet (FIG. 5), behind a knee of a bent leg, or under the buttocks. In addition, where an opposing member is a exercise second apparatus, or a second booster bar (FIG. 2N), or other suitable structure, two people may exercise in tandem with one holding and moving the booster bar 13, and the other holding and moving the opposing member 25.

[0048] An opposing member may be any suitable structure, including those illustrated herein, and the structures disclosed in Fuller, U.S. Pat. No. 5,125,649. As an example, the opposing member 25 may also be a flexible sling (FIG. 1). A flexible sling comprises a flexible non-elastic or elastic strap or web of sufficient width and length to be comfortable for the exercise contemplated. The distal end 26 of the elastic element 15 or opposing member 27 may also be attached to a fixed object, such furniture, a wall or closed door, which functions as or a part of an opposing member.

[0049] Any configuration of booster bar, elastic elements, opposing member, and respective attachments are contemplated as long as the booster bar and opposing member are held in a moving or fixed positions to oppose each other in a stretching exercise movement. For example, the booster bar can be held in the hands, with an opposing member sling under a foot or feet (FIG. 5). For example, booster can be placed over a shoulder, head, across the shoulders, with a hand or hands holding bar to provide a nonmoving attachment for stretching movement by a leg with its foot in the sling. In any exercise, the user can wrap or unwrap the elastic element around the bar, as required, to adjust the stretching length and adjust the force. The opposing member can also be a nonflexible platform with the elastic elements attached at its ends, similar in form to a swing seat (FIG. 5), or have a construction similar to a booster bar (FIG. 2L).

[0050] The shock cords are preferably seized, fused, taped, or the like, at each end to prevent unraveling. The near ends of the elastic elements are also preferably attached to the booster bar by a system that guards against sharp edges or pressure points bearing against the elastic elements which could cause chafing, which provides positive configurations for preventing the shock cords from pulling away from the booster bar regardless of the force exerted by a user, for preventing relative circumferential movement between the booster bar and the point of attachment of the shock cords to the booster bar, and allowing a user to at least partially wind the shock cords around the booster bar by rotating the booster bar about its long axis.

[0051] An exemplary configuration comprises a booster bar which is hollow, at least near its ends, with a hole near each end passing through the wall. The near ends of the shock cords are threaded through respective holes and out through

the open ends of the booster bar; providing a first knot at the near end of each shock cord. Each shock cord is pulled back such that the first knot is positioned inside the booster bar adjacent the hole; and a second knot is tied in each shock cord at a position adjacent the booster bar. As a variation, each shock cord, after having its first knot pulled back inside the booster bar, is looped around the booster bar, and passed under itself, thus providing the second knot.

[0052] An alternate method comprises utilizing a booster bar which bar has a hole, near each end, passing completely through the bar; threading the near ends of the shock cords through respective holes; providing a first knot at the near end of each shock cord adjacent the hole, and tying a second knot in each shock cord at a position adjacent the booster bar. The same variation as noted above may also be used in this configuration.

[0053] The distal ends **26** are attached to the opposing element by any suitable method, and can comprise knots, loops, metal or polymeric ties, rings or ties, sewing, wrapped tape, and the like.

[0054] It is also contemplated for each elastic element to join two, or more, elastic elements into a single elastic element. Such a multiple flexible element would comprise multiple elements at each end of the booster bar attached in a parallel arrangement.

[0055] An aspect is a system for attaching a web or strap to a shock cord, i.e., to an end of a flexible elastic element that may comprise one or a plurality of shock cords. As described above, conventional knots or metal fasteners can be used, but these have been found to be inadequate. Tension on the shock cords tends to loosen a knot and tends to pull shock cords from a fastener. In addition, as force is applied to the shock cords the tension also tends to deform the shock cord and alter its cross-section at the fastener. This combined with the cycling of stretching and unstretching of the shock cord increases the tendency for the shock cord to slip from fasteners and to cause knots to loosen.

[0056] A solution has been to find fasteners with an aggressive holding ability. These can be combined with knots, and include ratchet structures (zip ties), metal wrapping and compressing fasteners, wire wrapping, toothed, roughened or serrated structures, and the like. But these fasteners, which are made from a hard material, such as metals or molded plastics, will under force tend to cut or damage the shock cord at the fastening point, leading to premature wear and failure of the shock cord.

[0057] Knots will not cut the cord like fasteners, but continuous cycling of stretching and unstretching tends to work knots loose. Knots can be secured with fasteners, but this construction introduces the cutting and wear problems with fasteners. Another problem is that bulky knots and fasteners can present an aesthetically unpleasant appearance, which diminishes the commercial appeal of the product.

[0058] A solution that essentially eliminates the above problems is by use of a fastener knot that requires no separate fasteners. Because this fastener system is entirely cloth molded to cloth with no sharp edges, or hard fastener surfaces, it avoids the above recited problems associated with hard surface fasteners. In addition, the knot fastener becomes tighter with increased tension on the fastener, to where it can become impossible to loosen or undue the fastener. A person by using the exercise device will actually tighten and increase the strength of the fastener.

[0059] FIG. 6 illustrates the steps in forming the fastener. In FIGS. 6A to 6L, an exemplary flexible elastic element and its manufacture is shown. Referring to FIG. 6L, the terminal stage **601** of the elastic element comprise three shock cords.

[0060] Referring to FIG. 6A, before attachment to the strap **602**, the terminal stage is terminated with a loop **603** and a free end **605** of the shock cord. A knot fastener as here described can be formed on any looped end involving one or several shock cord strands, with or without a free end. The free end, if present, is formed into a bight to follow the loop as illustrated.

[0061] Referring to FIG. 6B a free end of a strap or web **602** is brought up through the loop, and (FIG. 6C) wrapped around the back the loop, and (FIG. 6D) again around both legs of the loop. The web free end is then pulled down through the loop toward the web (FIG. 6E), and wrapped by pulling the end back around and then again through the loop (FIG. 6F). The reverse side of the partial fastener in FIG. 6F is shown in FIG. 6G, showing the free web end **611** extending down through the loop **603**. As shown in FIG. 6H, the free end **611** is pulled under the web portion **612** that wraps around both legs of the loop. The result of the above is shown in FIGS. 6I and 6J. To complete the fastener it is massaged and tightened, and tension is applied to the web and shock cords, as well as the free ends. The tightened fastener is shown in FIG. 6K and FIG. 6J. The free ends of the shock cords and the web can then be trimmed up to the fastener to achieve a smooth appearance. The fastener is further secured by applying tension on the fastener through the shock cords and the web, which occurs every time the device is use.

[0062] In an aspect, where stages in the flexible elastic elements that are constructed with two or more shock cords, the shock cords are wound in a twisted or helical pattern. An example of this can be seen in FIG. 6K and FIG. 6J. The helical pattern presents a better appearance and helps hold the shock cords together without the necessity of ties or the like.

[0063] The helical pattern can be achieved as an elastic element is constructed. Any suitable system constructing the helical pattern is contemplated. As an example, in stages where there are more than one shock cord, each of the shock cords is twisted around its axis. After assembly of the elastic element, the shock cords relax and wind around each other. The twisting and the assembly can be used by suitable jigs or machinery.

[0064] Alternately, upon a jig or the like, a shock cord is wrapped around two pins. When the cord is wrapped around a pin and doubled back along the shock cord already in place, it is manually wrapped round the in-place shock cord in a helical pattern to form a twisted pair. When it is wrapped around and doubled back along the in-place twisted pair, the free end is likewise wound around the in-place twisted pair to form a helical or twisted bundle of three of cords. This operation can be continued to achieve the desired number of cords for the stage.

[0065] In a specific example the cord is wrapped around the studs $1\frac{1}{2}$ times to create a stage with three shock cords. As the cord is wrapped around the studs, and doubled back it is wrapped (as described above) to form a twisted helical pattern. From one end a length is measured a length of shock cord to form an adjacent stage with 1 shock cord. At the juncture of the one cord stage and the three cord stage, the shock cord is suitably secured to secure juncture of the stages. A suitable method to secure is to form a securing knot. For example, before the last double back of the cord at the juncture, the free

end of the cord is wrapped or looped around the two-cord bundle, the end brought through the just formed loop, around the single cord extending from the bundle and back down through the loop. The cord then is wrapped down around the two-twisted-cord bundle to form a three-twisted cord bundle and then through the loop or bight at the end of the three cord bundle. The knot is then tightened and the twisted cords manipulated to make them even Two views of this knot fastener are shown in FIGS. 7A and 7B. This fastener has the advantage of being self tightening and is doesn't include plastic or metal parts that many cut or tear the shock cord.

[0066] The juncture of the stages may also be secured by suitable fasteners or combinations of fasteners, such as those constructed as wrappings, clips, clasps, compression members, ties, or the like, made from cloth, plastic, metal, or the like.

[0067] The other end of the twisted bundle can then be attached to a suitable opposing means. For example, to a strap or web, in the manner described above, using the loop formed when the shock cord was doubled back during assembly as the loop for attaching the strap. The loop may also include a bight in the free end that was last wrapped around the bundle. During assembly, electrical tape and similar fastener may be used to temporarily hold the cords and cord ends in place.

[0068] In an aspect of the invention, the exercise system also includes a shoulder pad. Referring to FIG. 8, the shoulder pad is a pad **802** disposed at the center of the booster bar **801**. It is applied to the booster before one or both handles and flexible elements are attached. The length is long enough to use as a pad on the shoulder or other part of the body during exercise, but not so long as to interfere with the wrapping of the flexible element around the ends of the booster bar. The pad not only mitigates the discomfort from the pressure of the booster bar, but by distributing the force over a wider area will tone and smooth skin, and increase muscle tone. Pressure on any part of the body to achieve the toning and smoothing benefit can be accomplished during an exercise, or the booster bar can be simply pressed against the skin (e.g., on the neck, chin, face, over the voice box) and moved in a massaging motion.

[0069] As indicated above, the force provided by the elastic members can be adjusted by winding and unwinding the elastic members around the booster bar. This can be done before or during an exercise movement, where a user can incrementally increase or decrease the force by turning the booster bar during the movement. In addition, during a hard stretch, it is more difficult to hold the booster bar to prevent it from twisting under the hands and unwinding the flexible elastic elements.

[0070] In order to assist in the movement and holding the booster bar. Reference is made to FIGS. 9A to 9D. In the illustrated example, the booster bar **901** has handles **902** at the ends of the booster bar that are each equipped with a flexible outer end **903** that allow the user to bend the end to create a lever to assist in turning or holding the bar, as illustrated in FIGS. 9B and 9D. As illustrated, the handle can be grasped to bend or flex the handle which creates more leverage. To prevent twisting, one hand can be around the bar while pulling on the bar, and the other hand on the lever to "lock" the bar from twisting.

[0071] As indicated above, an aspect of the present system is attachment of the flexible elastic elements to an opposing member, such as flexible sling. The sling can be further modified to include foot loops to create a three-way foot strap.

Referring to FIG. 10, illustrated is an example of such a construction with three points of attachment. The strap **1001** comprises two loops **1003** for attachment separated by a flexible middle strap portion **1005**, also for attachment. The loops are also constructed of flexible straps. This embodiment allows for the user to place his foot or feet in the sling with no fear that the sling might slide under this feet. Since the loops and the portion between are flexible, the feet are not locked in any one position. This gives more flexibility by increasing the possible exercise movements, and increases the safety of the device.

[0072] As an example, one foot can be placed on the middle portion with one foot in a loop. The feet are free to move relative to one another and the user can incorporate more movement in the exercise, such as jumping. Both feet in each of the loops is even more secure, but because the middle portion is flexible, the feet can still move, and can participate in movement. Another advantage is that with both feet in each of the loops, when the booster bar tensions the flexible elements, the force on each foot is the same, and there is no tendency to force the feet together, both of which are harder to achieve with a simple strap.

[0073] With prior-art devices, or with a simple sling, it would be difficult to exercise with jumping, such as on a mini-trampoline. With the present construction this can be done easily and safely.

[0074] While certain specific embodiments and examples have been described, it will be recognized by those skilled in the art that many variations are possible without departing from the scope and spirit of this invention, and that the invention, as described by the claims, is intended to cover all changes and modifications of the invention which do not depart from the spirit of the invention.

What is claimed is:

1. An exercise apparatus comprising:

a rigid movable booster bar;

two flexible elastic elements, each attached to the booster bar at a near end with an attachment, the attachments spaced from each other and configured to allow winding the elastic element upon the booster bar by rotating the booster bar, and to allow a gripping region on the booster bar,

each flexible elastic element comprising at least two flexible shock cord stages, each having nonlinear stretching properties, with each stage having one or more flexible shock cords, and with at least two stages having a different stiffness,

the stages attached to each other end to end so that they are disposed serially along the length of the flexible element, such that when the element is stretched less stiff stages are initially stretched more than more stiff stages, and as stretching continues and less stiff stages approach stretching limit, stretching is transferred to more stiff stages by more stretching in more stiff stages,

a distal end of each flexible element configured for a moving or fixed attachment to allow stretching of the flexible element.

2. An exercise apparatus as in claim 1 wherein at least one stage has two or more flexible shock cords.

3. An exercise apparatus as in claim 2 wherein two stages with different stiffness have a different number of shock cords.

4. An exercise apparatus as in claim 2 wherein two stages with different stiffness comprise shock cord strands of a different stiffness.

5. An exercise apparatus as in claim 1 wherein a distal end of each flexible element is attached to a fixed object.

6. An exercise apparatus as in claim 1 wherein a distal end of each flexible element is attached to an opposing member.

7. An exercise apparatus as in claim 6 wherein the opposing member is movable.

8. An exercise apparatus as in claim 6 wherein the opposing member is a flexible strap with the distal ends attached to either end of the strap.

9. An exercise apparatus as in claim 8 wherein the flexible strap is elastic or non-elastic.

10. An exercise apparatus as in claim 6 wherein the opposing member is a nonflexible bar or platform.

11. An exercise apparatus as in claim 10 wherein the opposing member is configured the same as the booster bar.

12. An exercise apparatus as in claim 1 wherein the stages are attached to each other by one or more of knots, sewing, glue, fusion, clamps, ties, tape wrapping, and molded structures.

13. An exercise apparatus as in claim 1 wherein the attachment is a knot fastener.

14. An exercise apparatus as in claim 13 wherein the knot fastener has self tightening configuration with the strap passing through a loop, twice around both legs of the loop, down through the loop around and again through the loop, and under itself where it passes twice around both legs.

15. An exercise apparatus as in claim 1 wherein at least one stage is constructed of multiple shock cords in a helical pattern around each other.

16. An exercise apparatus as in claim 1 wherein the booster bar comprises a pad disposed around the bar at a center portion of the bar where it does not interfere with the winding of the elastic elements.

17. An exercise apparatus as in claim 1 wherein the booster bar comprises handles at each end of the booster bar that extend beyond the ends of the booster bar and can be flexed to form levers to resist twisting of or apply torque to the booster bar.

18. An exercise apparatus as in claim 8 wherein the flexible strap comprises two flexible loops separated by a flexible middle portion.

19. An exercise apparatus comprising:
a rigid movable booster bar;

two flexible elastic elements, each attached to the booster bar at a near end with an attachment, the attachments spaced from each other and configured to allow winding the elastic element upon the booster bar by rotating the booster bar, and to allow a gripping region on the booster bar,

each flexible elastic element comprising at least two non-linear flexible shock cord stages, with at least each stage having one or more flexible shock cords, and with at least two stages having a different stiffness with at least one stage having at least two shock cords in a helical pattern around each other,

the stages attached to each other end to end so that they are disposed serially along the length of the flexible element, such that when the element is stretched less stiff stages are initially stretched more than more stiff stages, and as stretching continues and less stiff stages approach stretching limit, stretching is transferred to more stiff stages by more stretching in more stiff stages,

a distal end of each flexible element configured for attachment to both ends of a flexible strap, the attachment at each end by a knot fastener that has self tightening configuration with the strap passing through a loop, twice around both legs of the loop, down through the loop around and again through the loop, and under itself where it passes twice around both legs,

the booster bar having a pad disposed around the bar at a center portion of the bar where it does not interfere with the winding of the elastic elements and having handles at each end of the booster bar that extend beyond the ends of the booster bar and can be flexed to form levers to resist twisting of or apply torque to the booster bar.

20. An exercise apparatus as in claim 19 wherein the flexible strap comprises two flexible loops separated by a flexible middle portion.

* * * * *