

(19) World Intellectual Property  
Organization  
International Bureau



(43) International Publication Date  
27 May 2004 (27.05.2004)

PCT

(10) International Publication Number  
**WO 2004/043659 A1**

- (51) International Patent Classification<sup>7</sup>: **B26F 1/26**, C25D 1/08
- (74) Agent: **VOLMER, J., C.**; Exter Polak & Charlouis B.V., P.O. Box 3241, NL-2280 GE Rijswijk (NL).
- (21) International Application Number: PCT/NL2003/000786
- (81) Designated States (*national*): AE, AG, AL, AM, AT, AU, AZ, BA, BB, BG, BR, BW, BY, BZ, CA, CH, CN, CO, CR, CU, CZ, DE, DK, DM, DZ, EC, EE, EG, ES, FI, GB, GD, GE, GH, GM, HR, HU, ID, IL, IN, IS, JP, KE, KG, KP, KR, KZ, LC, LK, LR, LS, LT, LU, LV, MA, MD, MG, MK, MN, MW, MX, MZ, NI, NO, NZ, OM, PG, PH, PL, PT, RO, RU, SC, SD, SE, SG, SK, SL, SY, TJ, TM, TN, TR, TT, TZ, UA, UG, US, UZ, VC, VN, YU, ZA, ZM, ZW.
- (22) International Filing Date: 10 November 2003 (10.11.2003)
- (25) Filing Language: Dutch
- (26) Publication Language: English
- (84) Designated States (*regional*): ARIPO patent (BW, GH, GM, KE, LS, MW, MZ, SD, SL, SZ, TZ, UG, ZM, ZW), Eurasian patent (AM, AZ, BY, KG, KZ, MD, RU, TJ, TM), European patent (AT, BE, BG, CH, CY, CZ, DE, DK, EE, ES, FI, FR, GB, GR, HU, IE, IT, LU, MC, NL, PT, RO, SE, SI, SK, TR), OAPI patent (BF, BJ, CF, CG, CI, CM, GA, GN, GQ, GW, ML, MR, NE, SN, TD, TG).
- (30) Priority Data:  
1021907 12 November 2002 (12.11.2002) NL  
1023005 24 March 2003 (24.03.2003) NL
- (71) Applicant (*for all designated States except US*): **STORK PRINTS B.V.** [NL/NL]; 1-3, Raamstraat, NL-5831 AT Boxmeer (NL).
- (72) Inventors; and
- (75) Inventors/Applicants (*for US only*): **THUIS, Henricus, Hermanus, Wilhelmus** [NL/NL]; Jacob van Ruysdaelstraat 20, NL-5831 CB Boxmeer (NL). **JECKMANS, Cornelis, Johannes** [NL/NL]; 3a, Carmelietenstraat Oost, NL-5831 DT Boxmeer (NL).
- Published:**  
— with international search report  
— before the expiration of the time limit for amending the claims and to be republished in the event of receipt of amendments
- For two-letter codes and other abbreviations, refer to the "Guidance Notes on Codes and Abbreviations" appearing at the beginning of each regular issue of the PCT Gazette.*

(54) Title: SCREEN MATERIAL MANUFACTURING METHOD AND APPLICATIONS THEREOF

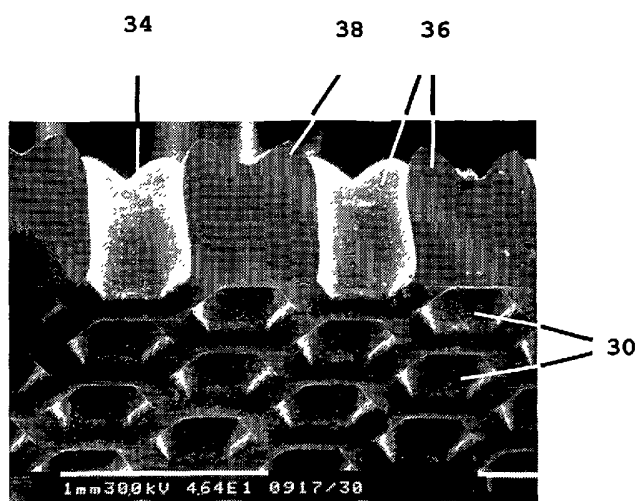

(57) Abstract: A metal screen material (32) having a flat side, in particular electroformed screen material, preferably seamless cylindrical screen material, comprises a network of dykes (34) which are connected to one another by crossing points (36), which dykes (34) delimit openings (30). The thickness of the crossing points (36) is not equal to the thickness of the dykes (34). The metal screen material (32) or a combination thereof with a perforating screen (17) can be used as a perforating stencil for the perforation of film material (2), for example made from plastic material.

WO 2004/043659 A1

Screen material, manufacturing method and applications thereof

5 According to a first aspect, the invention relates to a screen material made from metal having a flat side, comprising a network of dykes which are connected to one another by crossing points, which dykes delimit openings. More particularly, the invention according to this aspect relates to electroformed  
10 screen material, preferably seamless cylindrical screen material.

Screen material of this type is known in the specialist field and is used for numerous purposes, such as screen-printing,  
15 perforating plastic films, etc. A perforating method and device are known, for example, from US-A 6,024,553.

In this known method for manufacturing perforated plastic films, a thin plastic film is guided over a perforated cylinder, also  
20 known as a perforating stencil, and the film is locally exposed to a pressurized fluid, such as water or air. As a result, the film is locally deformed into the perforations of the perforated cylinder and is pressed into them until the film breaks, so that perforations are formed in the film at these locations.

25 The perforating stencil used in this known method comprises a moulding cylinder having an external moulding surface and an internal securing surface, and a support cylinder, which bears the moulding cylinder. A support structure of this type is often  
30 required in order to lengthen the service life of the stencil, which is adversely affected by the pressurized fluid, such as water. Discharge holes for discharging the fluid extend through the wall of the moulding cylinder. If the support cylinder covers certain discharge holes, there is a risk of no  
35 perforations or insufficient perforations being formed in the film at these locations. Also, the shape of a perforation which is formed may be adversely affected by fluid which splashes up or flows back. To avoid these risks, according to the above patent it is proposed to incorporate a fluid-permeable  
40 structure, such as a metal screen or mesh, between the moulding

- 2 -

cylinder and the support cylinder, the transverse dimensions (width) of the dykes or wires of the fluid-permeable structure being smaller than the largest diameter of the generally circular or oval discharge holes. All the discharge holes are therefore at least partially open, and (partial) blockage of the discharge holes is avoided. The fluid can be successfully drained away and discharged.

In general, it can be stated that a perforating stencil on the one hand has to have a sufficient strength and on the other hand good discharge of fluid has to be ensured.

The manufacture of a perforating stencil with a layered structure, in accordance with the above US patent, is complicated, however, on account of the need to align the openings in the various layers. This is because unaligned openings could give rise to what is known as the Moiré effect, on account of the presence of regular patterns of openings which partially overlap one another. This Moiré effect can give rise to an absence of perforations or an insufficient number of perforations in the plastic film.

On account of the abovementioned complexity of the known perforating stencil, there is a need for alternatives which on the one hand are sufficiently strong and on the other hand offer a good quality of perforation. It is an object of the invention to satisfy this requirement.

Furthermore, the present invention is based on the object of providing a screen material, in particular for use in the perforation of plastic films, in which the risk of the Moiré effect occurring is reduced.

To this end, the invention provides a metal screen material having a flat side, comprising a network of dykes which are connected to one another by crossing points, which dykes delimit openings, the thickness of the crossing points not being equal to the thickness of the dykes.

- 3 -

An important technical aspect of the screen material according to the invention is that the screen material, which has a flat side, does not have a uniform thickness (height), but rather the thickness of the crossing points, i.e. connecting points, of the separate dykes differs from that of the dykes themselves. When the screen material according to the invention is used as a support structure in a perforating stencil, this on the one hand provides a large number of support points for the perforating screen or moulding cylinder. On the other hand, this structure ensures that the perforating stencil has a good permeability, since there is sufficient permeability in the plane of the supporting structure between the dykes and crossing points. The differing height of the crossing points with respect to the dykes is only present on one side in the screen material according to the invention, specifically on the opposite side from the flat side. In this description, the term screen material is understood as meaning a thin material, the main surfaces of which are referred to as sides, to distinguish them from the thin side edges. The term "flat" means planar, without projecting parts. The screen material may, for example, be in plate form, but is preferably a seamless cylinder.

It should be noted that screen material based on a woven structure is known per se, and in this material if desired the threads of the woven structure are bound to one another by the application of an electroformed coating layer. However, a screen material of this type does not have any flat sides, since the threads of the woven structure cross one another on each side alternately. As a result of these thread crossings, the thickness of a screen material of this type is greater at the location of these crossing points than the thickness of the separate threads. Examples of screen materials of this type based on a woven structure are described, inter alia, in US-A 1,934,643, US-A 5,939,172, US-A 5,453,173, US-A 3,759,799, US-A 4,609,518 and the abovementioned document US-A 6,024,553.

In the invention, the screen material is advantageously made from a single piece, as will become apparent below from the description of a method used to manufacture it.

According to a preferred embodiment of the screen material according to the invention, the thickness of the crossing points is greater than the thickness of the dykes, as will be explained  
5 in more detail below. The difference between the thickness of the crossing points and the thickness of the dykes is preferably in the range from 20-250 micrometres, more preferably in the range from 100-200 micrometres.

10 With regard to the contact surface with a perforating screen above, the apex angle of an elevated crossing point is advantageously less than  $120^\circ$ , for example  $100^\circ$  in the case of a height difference of 130 micrometres.

15 The screen material is advantageously tubular, and more particularly the screen material is in the form of a seamless cylinder, so that the entire circumferential surface may be provided with screen openings, optionally in a regular pattern. The screen material, in particular in cylinder form, is  
20 preferably obtained electrolytically, as will be explained below.

The preferably electroformed screen material according to the invention, for use as a support screen in an assembly of support  
25 screen and perforating screen, which assembly is suitable for use for the perforation of thin films, advantageously has one or more of the following properties:

A mesh number of 30-80 mesh. By way of example, the openings are  
30 arranged in a hexagonal, orthogonal or other regular pattern. With a mesh number of less than 30, there is a risk of the support screen not supporting the perforating screen to a sufficient extent, while with a fineness of more than 80 mesh there is a risk of process water used to form perforations in  
35 the film by means of water jets being insufficiently drained away.

With a view to strength, the overall thickness of the screen material (including elevated sections) is advantageously greater

- 5 -

than 600 micrometres (typically 900-1000 micrometres). The permeability of the screen material (optical openness) is advantageously more than 25% (typically 40%-50%).

- 5 The metal used for the screen material according to the invention is preferably nickel.

According to a second aspect, the invention relates to a method for producing metal screen material having a flat side,  
10 comprising a network of dykes which are connected to one another by crossing points and which dykes delimit openings, in particular screen material according to the invention. The method according to the invention comprises at least one or more growth steps for electrolytically thickening a screen skeleton  
15 with flat sides in an electroplating bath under controlled conditions, in such a manner that in at least one growth step the growth rate of the crossing points is not equal to the growth rate of the dykes, so that in the screen material the thickness of the crossing points is not equal to the thickness  
20 of the dykes.

In this method according to the invention, the starting material used is a screen skeleton with two flat sides. A skeleton of this type is a very thin screen material which defines the basic  
25 two-dimensional shape of the network. A skeleton of this type can be obtained in a manner known per se, preferably by electroforming on an electrically conductive die which is provided with separate insulator islands, for example made from photoresist, which correspond to the screen openings which are  
30 to be formed. The dykes correspond to the die tracks or parts which are not covered with insulating material. According to the invention, this skeleton is subjected to one or more growth steps under controlled process conditions. Generally, an incipient height difference between dykes and crossing points is  
35 produced in a first step, and this height difference is then enhanced in subsequent steps.

In other words, the screen material is advantageously produced with the aid of a multistage electroforming process. This

process comprises:

Phase 1. The deposition of a metal screen skeleton with flat sides, for example made from nickel, on a die, preferably a  
5 cylindrical die.

Phase 2. This phase comprises one or more thickening steps or growth steps. The conditions of the thickening steps are selected in such a way that the desired dyke shape and crossing  
10 point shape are formed, it being possible for the height differences between the dykes and the crossing points to be either positive or negative, depending on what is desired or required for the intended application. The growth may take place on both sides, in which case, however, the differing growth rate  
15 with regard to the location of dykes and crossing points only occurs on one side. The thickening steps have a selective growth character, which manifests itself in electrolytic growth which preferably does not take place in the holes but does take place on the dykes and crossing points, i.e. there is scarcely any  
20 widening of the dykes or crossing points compared to the amount of growth in the thickness direction.

In one of the thickening steps, the dyke shape and the height difference of a basic shape of the screen material ultimately  
25 obtained are defined. During the subsequent step or steps, this basic shape can be grown further until the desired final thickness is reached, and the shape aspects are made more pronounced or enhanced.

30 The height differences which are formed in the thickening step which provides the basic shape are advantageously controlled by one or more of the following parameters.

Forced flow of the bath liquid through the screen skeleton. The  
35 flow rate of the electrolyte is advantageously in the range from 200-600 l/dm<sup>2</sup> per hour, and is typically 300 l/dm<sup>2</sup>/hour. If the flow rate of the electrolyte through the screen material is higher, uncontrolled turbulence occurs, with the result that the locations on the screen skeleton which are exposed to most

- 7 -

electrolyte agitation will grow the least. If the flow rate is low, there will be scarcely any selective growth.

Concentration of brightener. The concentration is advantageously in the range from 200-500 g/l (typically 400 g/l). An excessively high concentration of the brightener generally results in a brittle deposit. Lowering the brightener content reduces the selective growth character. It is preferable to use a brightener with properties belonging to the first and second classes. Examples of brighteners of this type are described in European Patent Application 0 492 731.

A current density of between 5 and 40 A/dm<sup>2</sup> (typically approximately 15 A/dm<sup>2</sup>).

Another factor which influences the local growth is what is known as the primary current distribution, which is related to the geometric distribution of the metal which is already present. Given an identical distance between anode and cathode (skeleton), narrow shapes grow to a greater extent than wider shapes.

The invention also relates to the use of the screen material according to the invention or the screen material obtained using the method according to the invention for the perforation of film material. The screen material according to the invention is advantageously used as a support screen, but can also be used as a perforating screen.

Furthermore, the invention relates to an assembly of a support screen and a perforating screen, in which the support screen comprises screen material according to the invention or screen material obtained using the method according to the invention. This assembly of concentric screens is also known as a perforating stencil. It is preferable for the mesh number of the support screen to be lower than that of the perforating screen.

When two screens with more or less regular patterns of openings are placed on top of one another, a Moiré effect generally



occurs as a result of interference. This effect may be disruptive in the perforated product, since perforations which it is intended to produce will not be formed or will not completely be formed. With the combination of screens according to the invention, this phenomenon is suppressed by the small contact area between the elevated crossing points of the support screen and the perforating screen. The ratio of the mesh numbers of the two screens also plays a role. It has been found that the Moiré effect for two regular patterns is least disruptive if the ratio between two repeat frequencies of the two patterns is an integer number  $\pm 0.5$  (1.5, 2.5; 3.5, etc.).

This means that in the case of a perforating screen of 100 mesh, the support screen preferably has one of the following mesh numbers: 66.6 mesh; 40 mesh; 28.6 mesh; 22.2 mesh, etc. The extent to which this Moiré formation is minimized (i.e. no longer perceptible) increases for coarser support screens. It has been found that the disruptive Moiré effect is no longer perceptible when a sheet is perforated using a 100 mesh perforating screen and a 40 mesh support screen in accordance with the invention.

The invention also relates to various methods for manufacturing an assembly of a tubular perforating screen and a tubular support screen.

A first method for manufacturing an assembly of a support screen and a perforating screen, in particular cylindrical (seamless) screens, comprises at least one step of shrinking the perforating screen onto the support screen.

During the electrolytic growth of screen material, internal stress is built up, as a function, inter alia, of the current intensity, the type of brightener which is added, the concentration of this brightener, the process temperature and the flow rate through the screen material in the direction of the anode. Subjecting the screen material to a heat treatment, for example in the case of nickel at a temperature of 120-220°C for approx. 1 hour, generally causes shrinkage of the screen

material of the order of 0.1%. In the method according to the invention, the shrinkage characteristics of the two screens are used to secure the screens taut to one another. In this case, it is advantageous for a cylindrical support screen to be subjected to a heat treatment at elevated temperature, so that a support screen with a defined outer diameter (OD) is obtained, and for a cylindrical perforating screen with an inner diameter (ID) which is slightly larger than the outer diameter (OD) of the support screen to be arranged over the support screen, and for the unit comprising support screen and perforating screen to be subjected to a heat treatment at a temperature which is lower than the temperature of the heat treatment of the support screen, for a sufficient time to shrink the perforating screen onto the support screen.

The method according to the invention produces a cylindrical support screen with a defined diameter, for example a diameter in the range from 200-1000 micrometres, advantageously greater than 600 micrometres. The process conditions, as indicated above, are selected in such a way that the stress which is incorporated will result in a shrinkage of 0.1%. The screen obtained in this way is subjected to a heat treatment, with the result that the diameter of the cylinder is reduced through shrinkage. The result is a cylindrical screen material with a defined outer diameter (OD). A second (outer) screen as perforating screen is produced with an inner diameter (ID) which is 0.1% larger than the OD of the support screen. The two screens are slid over one another and the assembly is subjected to a heat treatment at a temperature which is lower than the temperature of the heat treatment of the support screen. During this process step, the outermost screen will shrink in such a manner that it comes to bear taut around the base or support screen. On account of its rigidity, the screen combination obtained in this way has a longer service life than the outermost perforating screen alone.

Incidentally, it should be noted at this point that it is described in US-A 6,024,553 that the controlled shrinkage of the starting sleeve for the moulding cylinder can be used to define

its desired diameter with regard to the thickness of the porous structure.

Another method for manufacturing an assembly of a tubular  
5 support screen and a tubular perforating screen, in particular  
cylindrical seamless screens, according to the invention  
comprises at least one step of arranging a deformed support  
screen in the perforating screen and restoring the original  
10 shape of the support screen. In a preferred embodiment of this  
method, to restore the original shape of the support screen an  
inflatable container is placed into the support screen and is  
then pressurized. In this method, the ID of the outer screen is  
in principle selected to be equal to the OD of the inner screen.  
As a result of the inner screen being pressed into a kidney  
15 shape and the inner screen being positioned in the outer screen  
in this shape and then being returned to its original round  
shape with the aid of an inflatable container, such as an  
airbag, a good fit between the screens is obtained. In this  
case, the inner diameter of the perforating screen may  
20 advantageously be slightly smaller than the outer diameter of  
the support screen, so that an even tighter fit is obtained. The  
outer screen is then under tensile stress.

Yet another method for manufacturing an assembly of a support  
25 screen and a perforating screen, in particular cylindrical  
seamless screens, comprises at least one step of pushing the  
perforating screen over the support screen with the aid of a  
pressurized fluid. This method for positioning two screens taut  
around one another involves filling both the holes in the inner  
30 screen and the holes in the outer screen with a non-permanent  
agent, for example photoresist. By creating an air cushion  
between the innermost screen and the outermost screen comprising  
a pressurized fluid, such as compressed air, with the aid of a  
push-on flange, it is possible for the outermost screen to be  
35 stretched in such a manner that it can easily be slid over the  
inner screen. When the pressure is reduced, the outermost screen  
shrinks around the inner screen. If the inner screen is not  
sufficiently stable and dimensionally rigid to withstand the  
compressed air, a sufficiently strong auxiliary cylinder can be

- 11 -

introduced into the inner screen during this process step. After the screens have been pushed over one another, the resist is removed.

5 The invention is explained below with reference to the appended drawing, in which:

Figs. 1 and 2 are photographs of a screen material according to the invention;

10 Fig. 3 is a photograph of an assembly of a support screen and perforating screen according to the invention;

Fig. 4 shows a diagrammatic representation of the perforation of a plastic film; and

Fig. 5 shows a diagrammatic cross section through an embodiment of an assembly according to the invention.

15

#### EXAMPLE

A 40 mesh hexagonal screen was produced in the following way. The base was formed by a cylindrical Ni skeleton with flat inner and outer sides which was deposited on a die from an electrolytic bath. The thickness of the skeleton of 20 57 micrometres and a permeability of 53% are achieved at a current density of 30 A/dm<sup>2</sup>. A first thickening step took place with a flow rate through the skeleton of 240 l/dm<sup>2</sup> per hour from the inside outwards, a current density of 10 A/dm<sup>2</sup> with a 25 brightener concentration of 380 g/l. The brightener used was 1-(3-sulphopropyl)quinoline. The resulting basic shape had a thickness of 270 micrometres, a permeability of 50% and a height difference between the crossing points and the dykes of approximately 30 micrometres. The second thickening step took place with a brightener concentration of 420 g/l, a flow rate of 300 l/dm<sup>2</sup> per hour and a current density of 15 A/dm<sup>2</sup>. The 30 resulting screen material had a thickness of 900 micrometres, a permeability of 45% and a height difference between crossing points and dykes of 130 micrometres. The apex angle of the 35 crossing points was 90-110°. The height differences were present on the outer side, while the inner side had remained flat.

Figs. 1 and 2 show photographs of the resulting screen material,

in which the dykes are denoted by reference numeral 34, the openings by 30, the crossing points by 36 and the apex angle thereof by 38.

5 The screen material is preferably used as a support screen for a screen with a higher mesh number, for example with a mesh number of 100 mesh. For some applications, such as film perforation, it is desirable to use a screen with a mesh number of typically  
10 between 60 and 150 mesh. These types of screen are characterized by a limited stability with regard to the high forces which are applied to the screen material during the film-perforating process, for example vacuum perforation at elevated temperatures at which the film is deformable, or water-jet perforation at lower temperatures. Therefore, the open surface area of the  
15 support screen has to be larger than that of the perforating screen (outer screen). The elevations and the small apex angle ( $< 120^\circ$ ) of the crossing points prevent excessive numbers of holes in the perforating screen being completely or partially blocked, which would result in the sheet not being perforated at  
20 the positions of these holes. Cf. Figure 3, which shows a photograph of an assembly of a support screen 32 and a perforating screen 17. The perforating screen 17 is supported on the support screen 32 at the positions 40 indicated by dark round dots.

25 Fig. 4 illustrates the perforation of a plastic film using a perforating stencil. In Fig. 4, a thin plastic film 2, for example made from polyethylene, is unwound from a stock reel 4 and guided over a perforating stencil 6, where the film is  
30 perforated by water jets 8 with a pressure of, for example, 4 bar, from a water jet device 10. After perforation, the film 2, which has been provided with perforations 12, is wound up again onto a reel 14. The perforating stencil 6 is provided with a pattern of continuous openings 16.

35 Fig. 5 illustrates a cross section through an embodiment of a perforating stencil during operation. Identical components are denoted by identical reference numerals. The stencil 6 comprises an electroformed nickel moulding cylinder 17 as perforating

- 13 -

screen having a diameter of, for example, approximately 30 cm and a wall thickness of 600 micrometres, in which there are round openings 16 (mesh number 100) which are delimited by dykes 19. On the inside of the cylinder 17 there is a support screen 5 32 provided with openings 30. The openings 30 are delimited by dykes 34 of the support screen 32. The crossing points 36, which connect dykes 34 to one another, have a greater thickness than these dykes 34 themselves. At the location of an opening 16, the film is deformed under the pressure of a water jet 8 and is 10 pressed into the opening until the film 2 breaks. This results in the formation of a perforation 12 having the form indicated, which is favourable for numerous absorbent applications, and since the water is easily discharged via the support screen, this form of perforation is retained. The water which penetrates 15 through is drained away in a suitable way at the inner circumference of the support screen.

Examples of applications for perforated film include, inter alia, agricultural plastic, absorbent articles, including 20 absorbent products for personal care, for example diapers and sanitary towels. Applications of this nature make use of the (direction-dependent) permeability of the perforated film.

- 14 -

CLAIMS

1. Metal screen material having a flat side, comprising a network of dykes which are connected to one another by crossing points, which dykes delimit openings, the thickness of the crossing points (36) not being equal to the thickness of the dykes (34).  
5
2. Screen material according to claim 1, characterized in that the thickness of the crossing points (36) is greater than the thickness of the dykes (34).  
10
3. Screen material according to claim 1 or 2, characterized in that the difference between the thickness of the crossing points (36) and the thickness of the dykes (34) is in the range from 20-250 micrometres.  
15
4. Screen material according to claim 3, characterized in that the difference is in the range from 100-200 micrometres.  
20
5. Screen material according to one of the preceding claims, characterized in that the crossing points (36) have an apex angle (38) of less than 120°.
- 25 6. Screen material according to one of the preceding claims, characterized in that the screen material is in the form of a seamless cylinder.
7. Screen material according to one of the preceding claims, characterized in that the screen material is electroformed.  
30
8. Method for manufacturing metal screen material having a flat side, comprising a network of dykes which are connected to one another by crossing points, which dykes delimit openings, in particular according to one of the preceding claims, comprising at least one or more growth steps for electrolytically thickening a flat screen skeleton in an electroplating bath under controlled conditions, in such a manner that in at least one growth step the growth rate of the crossing points is not  
35

- 15 -

equal to the growth rate of the dykes, so that in the screen material the thickness of the crossing points is not equal to the thickness of the dykes.

- 5 9. Method according to claim 8, characterized in that the controlled conditions comprise a forced flow of the bath liquid through the screen skeleton.
- 10 10. Method according to claim 9, characterized in that the flow rate of the bath liquid is in the range from 200 l/dm<sup>2</sup> to 600 l/dm<sup>2</sup>.
- 15 11. Method according to one of the preceding claims 8-10, characterized in that the bath liquid comprises a brightener in a concentration in the range from 200-500 g/l.
- 20 12. Method according to claim 11, characterized in that the bath liquid comprises a brightener having properties of the first and second classes.
13. Method according to one of the preceding claims 8-12, characterized in that the current density is in the range from 5 to 40 A/dm<sup>2</sup>.
- 25 14. Use of the screen material according to one of the preceding claims 1-7 or the screen material obtained using the method according to one of the preceding claims 8-13 for the perforation of film material.
- 30 15. Assembly of a support screen and a perforating screen, in which the support screen comprises screen material according to one of the preceding claims 1-7 or the screen material obtained using the method according to one of the preceding claims 8-13.
- 35 16. Method for manufacturing an assembly of a tubular support screen and a tubular perforating screen, in particular cylindrical seamless screens, at least comprising a step of shrinking the perforating screen onto the support screen.



- 16 -

17. Method according to claim 16, characterized in that a cylindrical support screen is subjected to a heat treatment at elevated temperature, so that a support screen with a defined outer diameter (OD) is obtained, and in that a cylindrical perforating screen with an inner diameter (ID) which is slightly greater than the outer diameter (OD) of the support screen is fitted over the support screen, and the unit comprising support screen and perforating screen is subjected to a heat treatment at a temperature which is lower than the temperature used for the heat treatment of the support screen, for a sufficient time to shrink the perforating screen onto the support screen.

18. Method for manufacturing an assembly of a tubular support screen and a tubular perforating screen, in particular cylindrical seamless screens, at least comprising a step of arranging a deformed support screen in the perforating screen and restoring the original shape of the support screen.

19. Method according to claim 18, characterized in that to restore the original shape of the support screen, an inflatable container is placed into the support screen and is then pressurized.

20. Method according to claim 18 or 19, characterized in that the inner diameter of the perforating screen is slightly smaller than the outer diameter of the support screen.

21. Method for manufacturing an assembly of a tubular support screen and a tubular perforating screen, in particular cylindrical seamless screens, at least comprising a step of pushing the perforating screen over the support screen with the aid of a pressurized fluid.

22. Method according to one of the preceding claims 16-21, characterized in that a support screen according to one of claims 1-7 or obtained using the method according to one of claims 8-13 is used.

23. Use of the assembly according to claim 15 or obtained using

- 17 -

a method according to one of claims 16-22 for perforating film material.

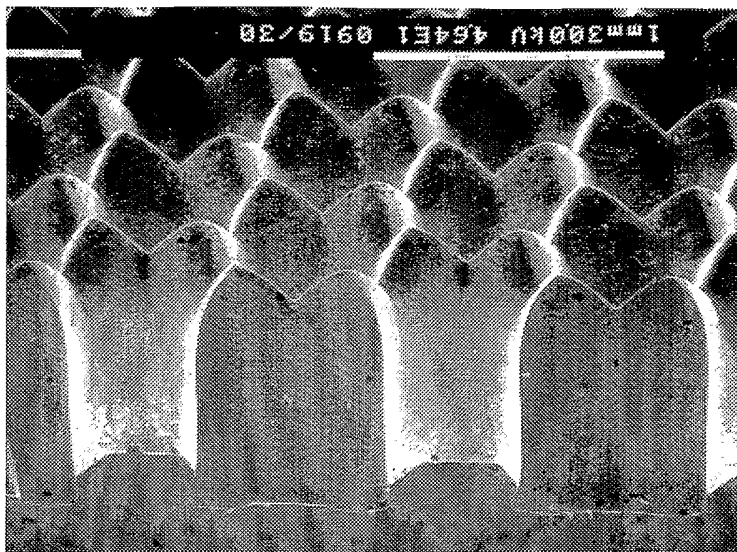

FIG. 1

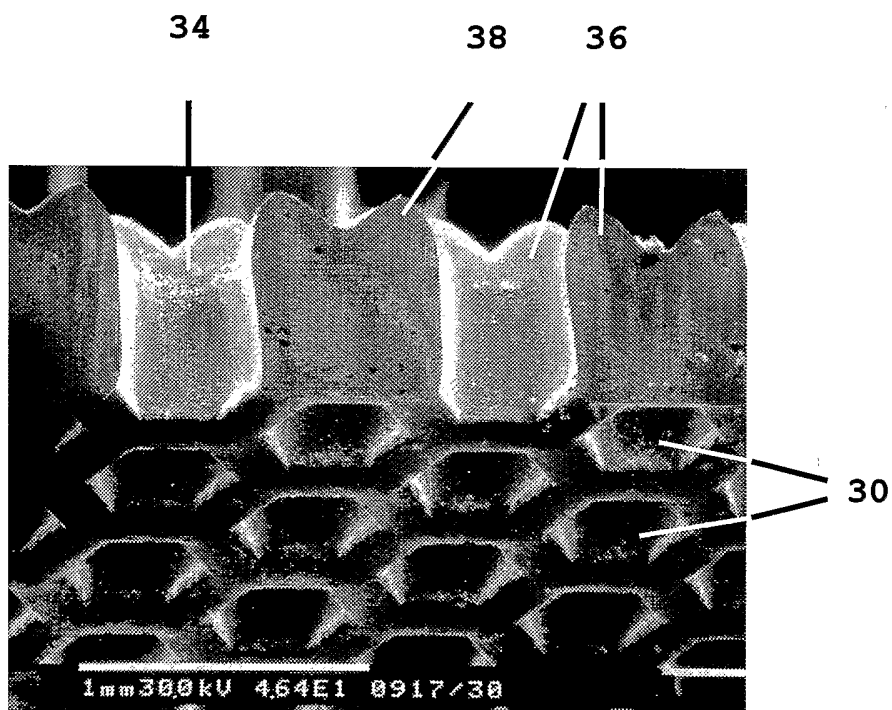

FIG. 2

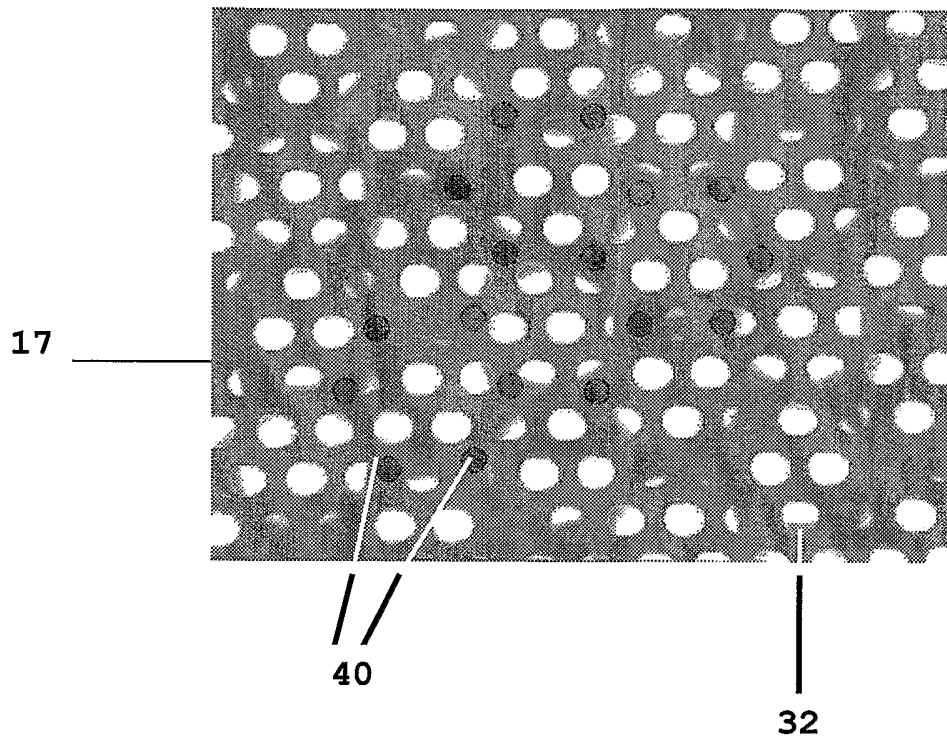

FIG. 3

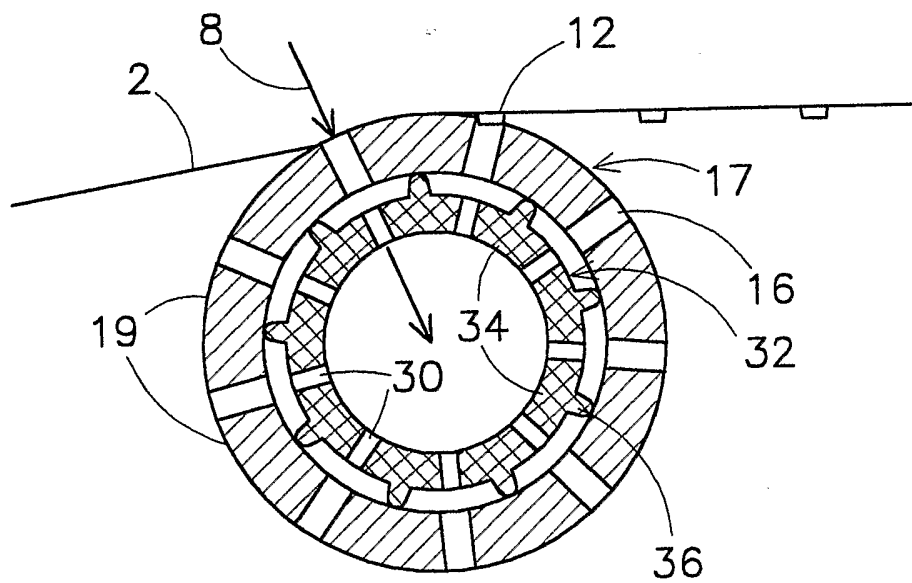
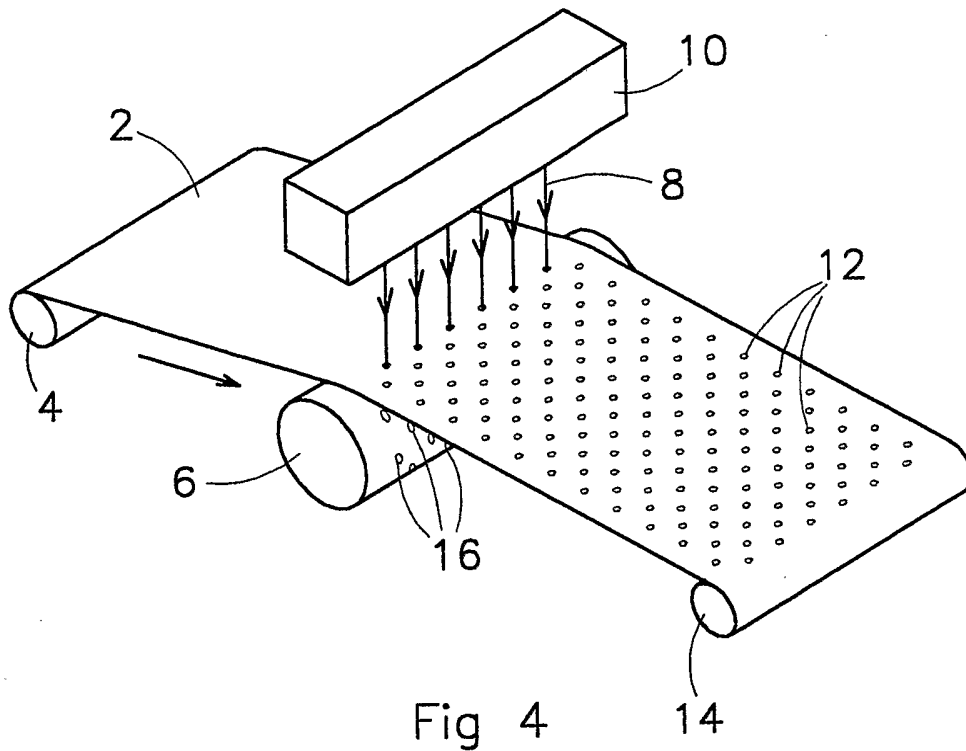

Fig 5

## INTERNATIONAL SEARCH REPORT

Application No

PCT/NL 03/00786

A. CLASSIFICATION OF SUBJECT MATTER  
 IPC 7 B26F1/26 C25D1/08

According to International Patent Classification (IPC) or to both national classification and IPC

## B. FIELDS SEARCHED

Minimum documentation searched (classification system followed by classification symbols)  
 IPC 7 B26F C25D B41C B41N

Documentation searched other than minimum documentation to the extent that such documents are included in the fields searched

Electronic data base consulted during the international search (name of data base and, where practical, search terms used)

EPO-Internal

## C. DOCUMENTS CONSIDERED TO BE RELEVANT

Category °	Citation of document, with indication, where appropriate, of the relevant passages	Relevant to claim No.
X	US 3 759 799 A (REINKE G) 18 September 1973 (1973-09-18) cited in the application the whole document ---	1,2,7
X	US 4 342 314 A (THOMPSON HUGH A ET AL) 3 August 1982 (1982-08-03) column 19, line 57 ---	1,2,6,7, 14
Y		3,4
X	US 5 514 105 A (GERTH DONALD L ET AL) 7 May 1996 (1996-05-07) column 7, line 50 - line 60; figures ---	1,2,5-7, 14
Y		3,4
Y	EP 0 862 904 A (UNI CHARM CORP) 9 September 1998 (1998-09-09) column 3, line 41 - line 48 column 4, line 12 - line 27; figures ---	3,4
	-/--	



Further documents are listed in the continuation of box C.



Patent family members are listed in annex.

° Special categories of cited documents :

"A" document defining the general state of the art which is not considered to be of particular relevance

"E" earlier document but published on or after the international filing date

"L" document which may throw doubts on priority claim(s) or which is cited to establish the publication date of another citation or other special reason (as specified)

"O" document referring to an oral disclosure, use, exhibition or other means

"P" document published prior to the international filing date but later than the priority date claimed

"T" later document published after the international filing date or priority date and not in conflict with the application but cited to understand the principle or theory underlying the invention

"X" document of particular relevance; the claimed invention cannot be considered novel or cannot be considered to involve an inventive step when the document is taken alone

"Y" document of particular relevance; the claimed invention cannot be considered to involve an inventive step when the document is combined with one or more other such documents, such combination being obvious to a person skilled in the art.

"&" document member of the same patent family

Date of the actual completion of the international search

6 April 2004

Date of mailing of the international search report

21.04.2004

Name and mailing address of the ISA

European Patent Office, P.B. 5818 Patentlaan 2  
 NL - 2280 HV Rijswijk  
 Tel. (+31-70) 340-2040, Tx. 31 651 epo nl,  
 Fax: (+31-70) 340-3016

Authorized officer

Vaglianti, G

## INTERNATIONAL SEARCH REPORT

In Application No  
PCT/NL 03/00786

C.(Continuation) DOCUMENTS CONSIDERED TO BE RELEVANT		
Category °	Citation of document, with indication, where appropriate, of the relevant passages	Relevant to claim No.
A	US 6 024 553 A (SHIMALLA CHARLES JAMES) 15 February 2000 (2000-02-15) cited in the application column 13, line 5 - line 15 column 13, line 50 -column 14, line 35; figures 10-12 column 15, line 11 - line 30 ---	1,2, 14-16,23
A	US 4 609 518 A (BAIRD JAMES C ET AL) 2 September 1986 (1986-09-02) cited in the application column 8, line 28 - line 29; figure 3 ---	1,2,14
A	US 1 934 643 A (ROBERT RAFTON HAROLD) 7 November 1933 (1933-11-07) cited in the application ---	
A	US 5 939 172 A (SNAKENBORG JOHANNES T ET AL) 17 August 1999 (1999-08-17) cited in the application the whole document ---	
A	US 5 453 173 A (OYAMA KANJI) 26 September 1995 (1995-09-26) cited in the application ---	
A	US 5 681 301 A (YANG CHING-YUN MORRIS ET AL) 28 October 1997 (1997-10-28) ---	
X	EP 0 049 022 A (VECO BEHEER BV) 7 April 1982 (1982-04-07) page 2, line 22 ---	8-10
Y		11-14
A		15
X	WO 99 20813 A (STORK VECO BV ;KORSSE JOHANNES (NL)) 29 April 1999 (1999-04-29) page 1, line 29 -page 3, line 22 ---	8,9
Y	EP 0 492 731 A (STORK SCREENS BV) 1 July 1992 (1992-07-01) examples 1,2 ---	11-14
Y	EP 0 038 104 A (STORK SCREENS BV) 21 October 1981 (1981-10-21) the whole document ---	11-14
Y	US 5 584 983 A (PRUYN WILHELMUS A) 17 December 1996 (1996-12-17) column 2, line 7 - line 15 column 3, line 4 -column 4, line 6 ---	11-14
X	WO 97 40213 A (STORK VECO BV ;AQUAMARIJN MICRO FILTRATION B (NL); KNOL HARM GERRI) 30 October 1997 (1997-10-30) the whole document ---	8,9
	-/--	

## INTERNATIONAL SEARCH REPORT

Int. Patent Application No  
PCT/NL 03/00786

C.(Continuation) DOCUMENTS CONSIDERED TO BE RELEVANT		
Category °	Citation of document, with indication, where appropriate, of the relevant passages	Relevant to claim No.
X	US 4 604 156 A (RALEY GARLAND E ET AL) 5 August 1986 (1986-08-05) column 6, line 38 - line 47; figures 3,4 -----	18



# INTERNATIONAL SEARCH REPORT

International application No.  
PCT/NL 03/00786

## Box I Observations where certain claims were found unsearchable (Continuation of item 1 of first sheet)

This International Search Report has not been established in respect of certain claims under Article 17(2)(a) for the following reasons:

1.  Claims Nos.:  
because they relate to subject matter not required to be searched by this Authority, namely:
  
2.  Claims Nos.:  
because they relate to parts of the International Application that do not comply with the prescribed requirements to such an extent that no meaningful International Search can be carried out, specifically:
  
3.  Claims Nos.:  
because they are dependent claims and are not drafted in accordance with the second and third sentences of Rule 6.4(a).

## Box II Observations where unity of invention is lacking (Continuation of item 2 of first sheet)

This International Searching Authority found multiple inventions in this international application, as follows:

see additional sheet

1.  As all required additional search fees were timely paid by the applicant, this International Search Report covers all searchable claims.
  
2.  As all searchable claims could be searched without effort justifying an additional fee, this Authority did not invite payment of any additional fee.
  
3.  As only some of the required additional search fees were timely paid by the applicant, this International Search Report covers only those claims for which fees were paid, specifically claims Nos.:  
  
1-20, 22, 23 (claim 22 only when it depends from claims 8-13 and 16-20,  
claim 23 only when it depends from claims 1-7, 8-13 and 16-20)
  
4.  No required additional search fees were timely paid by the applicant. Consequently, this International Search Report is restricted to the invention first mentioned in the claims; it is covered by claims Nos.:

### Remark on Protest

- The additional search fees were accompanied by the applicant's protest.
- No protest accompanied the payment of additional search fees.

**FURTHER INFORMATION CONTINUED FROM PCT/ISA/ 210**

This International Searching Authority found multiple (groups of) inventions in this international application, as follows:

1. Claims: 1-7, 14, 15 and 23 (claims 14, 15 and 23 only when they depend from claims 1-7)

metal screen material and methods of using it

2. Claims: 8-15, 22 and 23 (claims 14, 15, 22 and 23 only when they depend from claims 8-13)

method of electrolytically growing metal screen material, a screen obtained by the method and methods of using it

3. Claims: 16-20, 22 and 23 (claims 22 and 23 only when they depend from claims 16-20)

methods of bonding a support screen material, and a method of using it

4. Claims: 21-23 (claims 22 and 23 only when they depend from claim 21)

method of positioning a perforating screen material over a support screen material and a method of using it

## INTERNATIONAL SEARCH REPORT

Information on patent family members

International Application No

PCT/NL 03/00786

Patent document cited in search report		Publication date	Patent family member(s)	Publication date
US 3759799	A	18-09-1973	NONE	
US 4342314	A	03-08-1982	AT 6604 T	15-03-1984
			AU 541677 B2	17-01-1985
			AU 5611480 A	11-09-1980
			BR 8001307 A	04-11-1980
			CA 1140319 A1	01-02-1983
			CA 1155274 A2	18-10-1983
			DE 3066902 D1	19-04-1984
			EP 0018020 A1	29-10-1980
			ES 250912 U	01-01-1981
			ES 252982 Y	01-07-1982
			ES 8103977 A1	01-07-1981
			GR 67004 A1	18-05-1981
			HK 99288 A	16-12-1988
			IE 49278 B1	04-09-1985
			JP 1735236 C	17-02-1993
			JP 4008221 B	14-02-1992
			JP 55146738 A	15-11-1980
			JP 1937942 C	09-06-1995
			JP 3184541 A	12-08-1991
			JP 5028626 B	26-04-1993
			JP 1794258 C	14-10-1993
			JP 3198850 A	30-08-1991
			JP 5000066 B	05-01-1993
			MX 153289 A	11-09-1986
			US 4508256 A	02-04-1985
US 5514105	A	07-05-1996	AT 134130 T	15-02-1996
			AU 673511 B2	14-11-1996
			AU 3418293 A	28-07-1993
			BR 9207021 A	05-12-1995
			CA 2126067 A1	08-07-1993
			CN 1075178 A ,B	11-08-1993
			CN 1121663 A ,B	01-05-1996
			DE 69208373 D1	28-03-1996
			DE 69208373 T2	12-09-1996
			DK 619727 T3	11-03-1996
			EG 19757 A	31-01-1996
			EP 0619727 A1	19-10-1994
			ES 2083278 T3	01-04-1996
			GR 3019003 T3	31-05-1996
			HK 1006139 A1	12-02-1999
			JP 3461826 B2	27-10-2003
			JP 7502444 T	16-03-1995
			KR 249603 B1	15-03-2000
			MX 9207650 A1	31-05-1994
			SG 59983 A1	22-02-1999
			WO 9312749 A1	08-07-1993
EP 0862904	A	09-09-1998	JP 3484037 B2	06-01-2004
			JP 10216171 A	18-08-1998
			CN 1200262 A ,C	02-12-1998
			DE 69805465 D1	27-06-2002
			DE 69805465 T2	31-10-2002
			EP 0862904 A2	09-09-1998
			ID 21842 A	05-08-1999
			SG 72785 A1	23-05-2000

## INTERNATIONAL SEARCH REPORT

Information on patent family members

International Application No

PCT/NL 03/00786

Patent document cited in search report		Publication date	Patent family member(s)	Publication date
EP 0862904	A		TW 435212 Y US 6013348 A	16-05-2001 11-01-2000
US 6024553	A	15-02-2000	US 6315547 B1 US 6312640 B1 US 6660361 B1	13-11-2001 06-11-2001 09-12-2003
US 4609518	A	02-09-1986	AT 56914 T AU 577256 B2 AU 5809086 A CA 1299332 C DE 3674467 D1 DK 257086 A EG 17607 A EP 0203820 A2 ES 8707136 A1 ES 8707888 A1 ES 8707889 A1 ES 8801145 A1 ES 8707890 A1 FI 862306 A ,B, GB 2175842 A ,B GR 861374 A1 HK 50892 A IE 57451 B1 JP 2541515 B2 JP 62057975 A JP 2609085 B2 JP 8226065 A JP 2609086 B2 JP 8226066 A KR 9403178 B1 MX 165255 B PH 22977 A PT 82642 A ,B SG 48692 G ZA 8603938 A	15-10-1990 15-09-1988 04-12-1986 28-04-1992 31-10-1990 01-12-1986 30-06-1992 03-12-1986 01-10-1987 16-11-1987 16-11-1987 01-03-1988 16-11-1987 01-12-1986 10-12-1986 27-08-1986 17-07-1992 09-09-1992 09-10-1996 13-03-1987 14-05-1997 03-09-1996 14-05-1997 03-09-1996 15-04-1994 04-11-1992 10-02-1989 01-06-1986 12-06-1992 30-11-1988
US 1934643	A	07-11-1933	NONE	
US 5939172	A	17-08-1999	NL 9302238 A AT 179225 T AU 680707 B2 AU 1250495 A BR 9408399 A CA 2179527 A1 CN 1138354 A DE 69418060 D1 DE 69418060 T2 EP 0736111 A1 HK 1005996 A1 JP 2775200 B2 JP 9507043 T WO 9517534 A1 NO 962499 A NZ 277320 A SG 52431 A1 ZA 9410273 A	17-07-1995 15-05-1999 07-08-1997 10-07-1995 12-08-1997 29-06-1995 18-12-1996 27-05-1999 19-08-1999 09-10-1996 07-04-2000 16-07-1998 15-07-1997 29-06-1995 13-06-1996 26-05-1997 28-09-1998 07-09-1995

## INTERNATIONAL SEARCH REPORT

Information on patent family members

International Application No

PCT/NL 03/00786

Patent document cited in search report		Publication date	Patent family member(s)	Publication date
US 5453173	A	26-09-1995	JP 3100254 B2	16-10-2000
			JP 6220683 A	09-08-1994
			DE 4400440 A1	04-08-1994
US 5681301	A	28-10-1997	AU 1745797 A	20-08-1997
			BR 9707183 A	23-03-1999
			CA 2242858 A1	31-07-1997
			CN 1213959 A	14-04-1999
			DE 69722377 D1	03-07-2003
			EP 0879041 A1	25-11-1998
			JP 2000504245 T	11-04-2000
			RU 2175538 C2	10-11-2001
			WO 9726850 A1	31-07-1997
			ZA 9700575 A	23-07-1998
EP 0049022	A	07-04-1982	NL 8005427 A	16-04-1982
			AT 15237 T	15-09-1985
			CA 1215933 A1	30-12-1986
			DE 3172036 D1	03-10-1985
			EP 0049022 A1	07-04-1982
			HK 8190 A	09-02-1990
			JP 1047556 B	16-10-1989
			JP 1570084 C	10-07-1990
			JP 57092189 A	08-06-1982
			US 4397715 A	09-08-1983
US 4478688 A	23-10-1984			
WO 9920813	A	29-04-1999	NL 1007317 C2	21-04-1999
			AU 9653098 A	10-05-1999
			EP 1025286 A1	09-08-2000
			WO 9920813 A1	29-04-1999
EP 0492731	A	01-07-1992	NL 9002866 A	16-07-1992
			AT 135754 T	15-04-1996
			AU 634920 B2	04-03-1993
			AU 8979391 A	25-06-1992
			BR 9105530 A	01-09-1992
			CA 2058109 A1	25-06-1992
			CN 1062772 A ,B	15-07-1992
			DE 69118147 D1	25-04-1996
			DE 69118147 T2	05-09-1996
			DK 492731 T3	15-04-1996
			EP 0492731 A1	01-07-1992
			ES 2085958 T3	16-06-1996
			FI 916090 A ,B,	25-06-1992
			GR 3020278 T3	30-09-1996
			HK 210796 A	06-12-1996
			JP 2079996 C	09-08-1996
			JP 4311594 A	04-11-1992
			JP 7091673 B	04-10-1995
			KR 127832 B1	26-12-1997
			NO 914963 A	25-06-1992
NZ 241124 A	26-05-1993			
PT 99884 A ,B	28-02-1994			
US 5282951 A	01-02-1994			
ZA 9109874 A	30-09-1992			
EP 0038104	A	21-10-1981	NL 8002197 A	16-11-1981

# INTERNATIONAL SEARCH REPORT

Information on patent family members

In	tional Application No
PCI/NL 03/00786	

Patent document cited in search report	A	Publication date	Patent family member(s)	Publication date
EP 0038104	A		AT 12264 T	15-04-1985
			DE 3169332 D1	25-04-1985
			EP 0038104 A1	21-10-1981
			ES 264260 Y	01-06-1983
			ES 8302125 A1	01-04-1983
			HK 10690 A	16-02-1990
			JP 1586877 C	19-11-1990
			JP 2006837 B	14-02-1990
			JP 56166388 A	21-12-1981
			JP 1079392 A	24-03-1989
			JP 1631034 C	26-12-1991
			JP 2053518 B	16-11-1990
			US 4383896 A	17-05-1983
US 5584983	A	17-12-1996	NL 9200350 A	16-09-1993
			AT 162559 T	15-02-1998
			CA 2089965 A1	27-08-1993
			DE 69316407 D1	26-02-1998
			DE 69316407 T2	07-05-1998
			DK 558142 T3	14-04-1998
			EP 0558142 A1	01-09-1993
			HK 1005779 A1	22-01-1999
			JP 2829474 B2	25-11-1998
			JP 6081187 A	22-03-1994
			JP 3101922 B2	23-10-2000
			JP 10251886 A	22-09-1998
			US 5503941 A	02-04-1996
WO 9740213	A	30-10-1997	NL 1002908 C2	21-10-1997
			AU 2578297 A	12-11-1997
			DE 69701189 D1	24-02-2000
			DE 69701189 T2	21-06-2000
			EP 0894157 A1	03-02-1999
			WO 9740213 A1	30-10-1997
			US 6036832 A	14-03-2000
US 4604156	A	05-08-1986	US 4543299 A	24-09-1985
			BE 905121 A7	03-11-1986
			CA 1243176 A1	18-10-1988
			DE 3484298 D1	25-04-1991
			EP 0147013 A2	03-07-1985
			ES 296810 U	01-03-1988
			JP 1614724 C	15-08-1991
			JP 2040501 B	12-09-1990
			JP 60155436 A	15-08-1985
			US 4585156 A	29-04-1986