

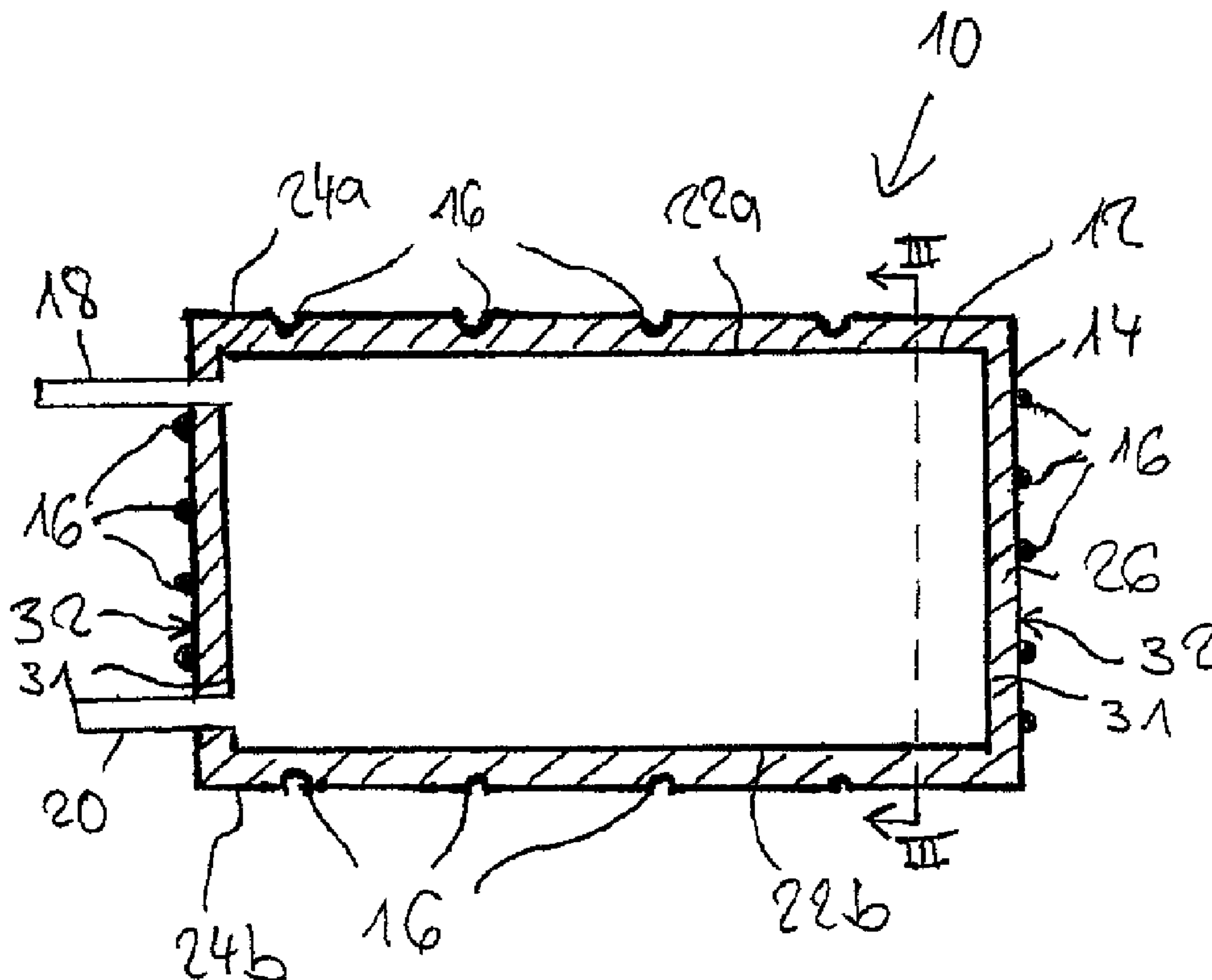

(86) Date de dépôt PCT/PCT Filing Date: 2006/10/12  
 (87) Date publication PCT/PCT Publication Date: 2007/04/19  
 (85) Entrée phase nationale/National Entry: 2008/04/10  
 (86) N° demande PCT/PCT Application No.: DE 2006/001799  
 (87) N° publication PCT/PCT Publication No.: 2007/042012  
 (30) Priorité/Priority: 2005/10/14 (DE10 2005 049 257.6)

(51) Cl.Int./Int.Cl. *F24H 1/18* (2006.01)  
 (71) Demandeur/Applicant:  
 WEBASTO AG, DE  
 (72) Inventeur/Inventor:  
 FIUMIDINISI, ALESSANDRO, IT  
 (74) Agent: GOWLING LAFLEUR HENDERSON LLP

(54) Titre : BALLON D'EAU CHAUDE  
 (54) Title: HOT WATER TANK



(57) Abrégé/Abstract:

Disclosed is a hot water tank (10) comprising an outer container (14) and an inner container (12) that is disposed inside the outer container (14), is used for receiving hot water, and is located at a distance from the outer container (14). A heat insulation layer (26) is placed between the inner container (12) and the outer container (14). The inner container (12) is provided with planar polygonal walls (22a, 22b, 28, 28b) while the outer container (14) is provided with planar polygonal walls (24a, 24b, 30a, 30b). The inner container (12) and/or the outer container (14) are equipped with supporting elements (16) which are configured so as to counteract an internal pressure of the hot water tank (10) in order for the hot water tank (10) to maintain the shape thereof.

## (12) NACH DEM VERTRAG ÜBER DIE INTERNATIONALE ZUSAMMENARBEIT AUF DEM GEBIET DES PATENTWESENS (PCT) VERÖFFENTLICHTE INTERNATIONALE ANMELDUNG

(19) Weltorganisation für geistiges Eigentum  
Internationales Büro(43) Internationales Veröffentlichungsdatum  
19. April 2007 (19.04.2007)

PCT

(10) Internationale Veröffentlichungsnummer  
**WO 2007/042012 A3**(51) Internationale Patentklassifikation:  
F24H 1/18 (2006.01)

(21) Internationales Aktenzeichen: PCT/DE2006/001799

(22) Internationales Anmeldedatum:  
12. Oktober 2006 (12.10.2006)

(25) Einreichungssprache: Deutsch

(26) Veröffentlichungssprache: Deutsch

(30) Angaben zur Priorität:  
10 2005 049 257.6  
14. Oktober 2005 (14.10.2005) DE

(71) Anmelder (für alle Bestimmungsstaaten mit Ausnahme von US): WEBASTO AG [DE/DE]; Kraillinger Str. 5, 82131 Stockdorf (DE).

(72) Erfinder; und

(75) Erfinder/Anmelder (nur für US): FIUMIDINISI, Alessandro [IT/IT]; Via Degli Orti 13, I-20016 Pero Milano (IT).

(74) Anwalt: EPPING HERMANN FISCHER PATENTANWALTSGESELLSCHAFT MBH; Ridlerstr. 55, 80339 München (DE).

(81) Bestimmungsstaaten (soweit nicht anders angegeben, für jede verfügbare nationale Schutzrechtsart): AE, AG, AL, AM, AT, AU, AZ, BA, BB, BG, BR, BW, BY, BZ, CA, CH, CN, CO, CR, CU, CZ, DE, DK, DM, DZ, EC, EE, EG, ES, FI, GB, GD, GE, GH, GM, HN, HR, HU, ID, IL, IN, IS, JP, KE, KG, KM, KN, KP, KR, KZ, LA, LC, LK, LR, LS, LT, LU, LV, LY, MA, MD, MG, MK, MN, MW, MX, MY, MZ, NA, NG, NI, NO, NZ, OM, PG, PH, PL, PT, RO, RS, RU, SC, SD, SE, SG, SK, SL, SM, SV, SY, TJ, TM, TN, TR, TT, TZ, UA, UG, US, UZ, VC, VN, ZA, ZM, ZW.

(84) Bestimmungsstaaten (soweit nicht anders angegeben, für jede verfügbare regionale Schutzrechtsart): ARIPO (BW, GH, GM, KE, LS, MW, MZ, NA, SD, SL, SZ, TZ, UG, ZM, ZW), eurasisches (AM, AZ, BY, KG, KZ, MD, RU, TJ, TM), europäisches (AT, BE, BG, CH, CY, CZ, DE, DK, EE, ES, FI, FR, GB, GR, HU, IE, IS, IT, LT, LU, LV, MC,

[Fortsetzung auf der nächsten Seite]

(54) Title: HOT WATER TANK

(54) Bezeichnung: WARMWASSERSPEICHER

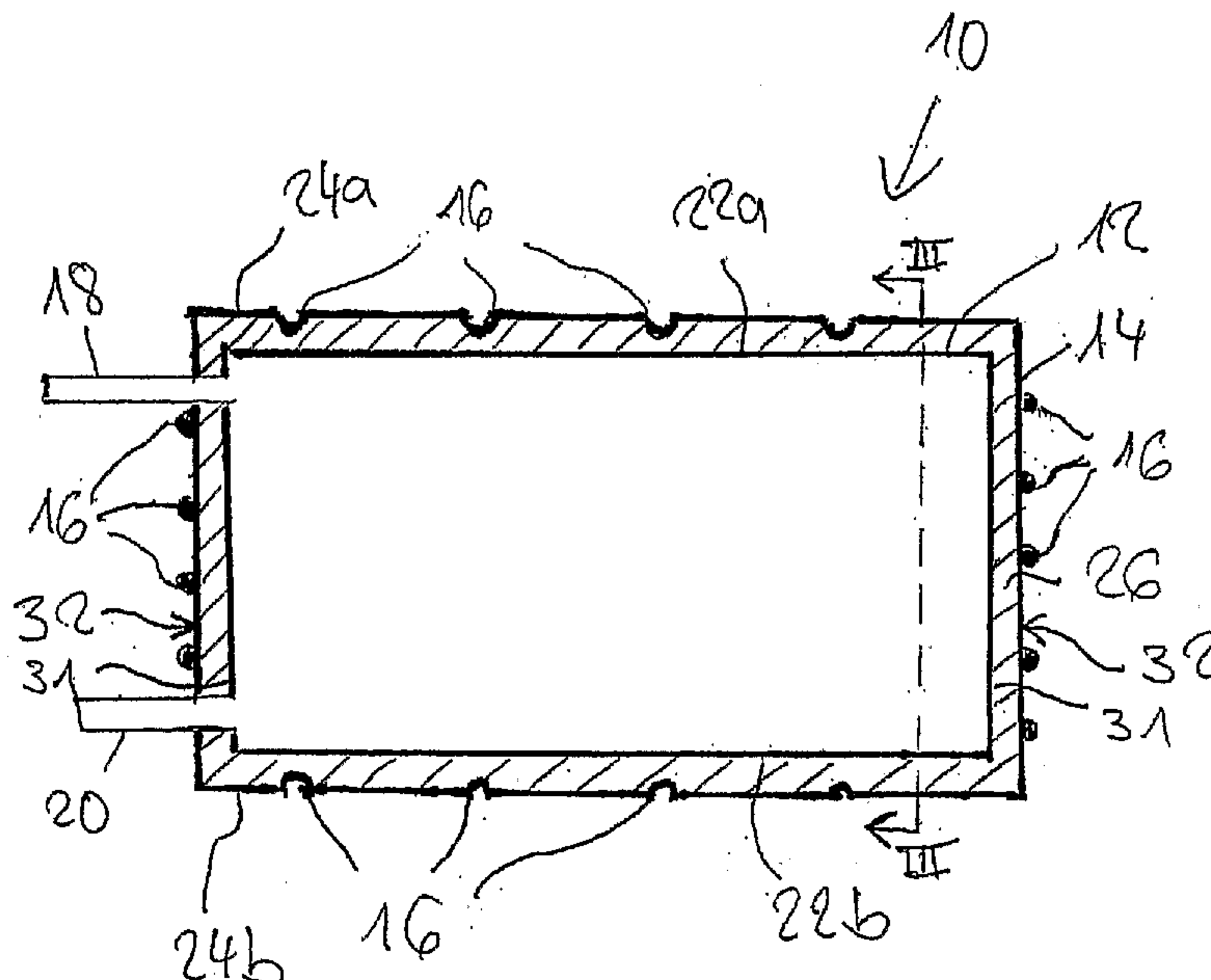

(57) Abstract: Disclosed is a hot water tank (10) comprising an outer container (14) and an inner container (12) that is disposed inside the outer container (14), is used for receiving hot water, and is located at a distance from the outer container (14). A heat insulation layer (26) is placed between the inner container (12) and the outer container (14). The inner container (12) is provided with planar polygonal walls (22a, 22b, 28, 28b) while the outer container (14) is provided with planar polygonal walls (24a, 24b, 30a, 30b). The inner container (12) and/or the outer container (14) are equipped with supporting elements (16) which are configured so as to counteract an internal pressure of the hot water tank (10) in order for the hot water tank (10) to maintain the shape thereof.

[Fortsetzung auf der nächsten Seite]

WO 2007/042012 A3

**WO 2007/042012 A3**

NL, PL, PT, RO, SE, SI, SK, TR), OAPI (BF, BJ, CF, CG, CI, CM, GA, GN, GQ, GW, ML, MR, NE, SN, TD, TG).

— vor Ablauf der für Änderungen der Ansprüche geltenden Frist; Veröffentlichung wird wiederholt, falls Änderungen eintreffen

**Erklärung gemäß Regel 4.17:**

— hinsichtlich der Berechtigung des Anmelders, die Priorität einer früheren Anmeldung zu beanspruchen (Regel 4.17 Ziffer iii)

**(88) Veröffentlichungsdatum des internationalen Recherchenberichts:**

21. Juni 2007

**Veröffentlicht:**

— mit internationalem Recherchenbericht

Zur Erklärung der Zweibuchstaben-Codes und der anderen Abkürzungen wird auf die Erklärungen ("Guidance Notes on Codes and Abbreviations") am Anfang jeder regulären Ausgabe der PCT-Gazette verwiesen.

**(57) Zusammenfassung:** Warmwasserspeicher (10) mit einem Außenbehälter (14), einem in dem Außenbehälter (14) angeordneten Innenbehälter (12), der der Aufnahme von Warmwasser dient und der von dem Außenbehälter (14) beabstandet ist. Zwischen dem Innenbehälter (12) und dem Außenbehälter (14) ist eine Wärmedämmschicht (26) angeordnet. Der Innenbehälter (12) weist ebene polygonförmige Wände (22a, 22b, 28, 28b) auf und der Außenbehälter (14) weist ebene polygonförmige Wände (24a, 24b, 30a, 30b) auf. Der Innenbehälter (12) und/oder der Außenbehälter (14) weisen Stützelemente (16) auf, die so ausgebildet sind, dass sie einem Innendruck des Warmwasserspeichers (10) entgegenwirken, damit der Warmwasserspeicher (10) seine Form beibehält.

## Hot water tank

The invention relates to a hot water tank, with an outer container, with an inner container which is arranged in the outer container and which serves for the reception of hot water and is spaced apart from the outer container, and with a heat insulation layer which is arranged between the inner container and the outer container.

Hot water tanks of this type may be used, for example, as boilers, in service water installations or as buffer stores in heating systems.

Such a hot water tank is known, for example, from DE 35 27 315 A1. The outer container and inner container are essentially cylindrical and are manufactured from a relatively thin-walled material, for example from sheet steel. An insulating foam is arranged between the outer container and the inner container. A heat-insulating and mechanically stable composite structure consisting of the inner container, heat insulation layer and outer container can consequently be provided.

It is desirable also to use hot water tanks of this type in confined conditions of space, such as occur, for example, in motor vehicles, in particular in mobile homes or other camping vehicles.

The object of the invention is to provide a hot water tank which can be adapted effectively to predetermined conditions of space and can be produced cost-effectively.

The object is achieved by means of the features of the independent patent claims. Advantageous developments of the invention are characterized in the subclaims.

According to a first aspect, the hot water tank of the type initially mentioned is distinguished in that the inner container has planar polygonal walls and the outer container has planar polygonal walls. The planar polygonal walls of the inner container and/or of the outer container have supporting elements which are designed such that they counteract an internal pressure of the hot water tank so that the hot water tank preserves its shape.

The planar polygonal walls of the hot water tank make it possible to adapt the hot water tank to spaces of any desired configuration and geometry. Consequently, the spaces which are of any desired shape can be utilized particularly effectively for receiving a hot water tank. Furthermore, by means of the supporting elements, a dimensionally stable design of the planar polygonal walls of the hot water tank can be achieved. It is possible, in particular, to avoid the situation where a deformation of the planar polygonal walls occurs due to the internal pressure of the hot water tank.

In an advantageous refinement of the invention, the inner container has at least two polygonal walls which lie opposite one another and are parallel to one another, and the outer container has at least two polygonal walls which lie opposite one another and are parallel to one another. It thereby becomes possible for the hot water tank to be fitted into spaces having, in particular, parallel walls.

In an advantageous refinement of the invention, the inner container has at least four polygonal walls, of which in each case two lie opposite one another and are parallel to one another, and the outer container has at least four polygonal walls, of which in each case two lie opposite one another and are parallel to one another.

The advantage of this is that the hot water tank can be adapted to installation spaces having a plurality of walls parallel to one another.

In a further advantageous embodiment of the invention, at least two polygonal walls of the inner container which lie opposite one another are congruent with one another, and at least two polygonal walls of the outer container which lie opposite one another are congruent with one another.

It is particularly advantageous if the polygonal walls are rectangular. It is consequently possible to adapt the hot water tank to orthogonally designed installation spaces. Thus, for example, the hot water tank can advantageously be used particularly effectively in buildings in a basement boiler room with confined conditions of space and also in vehicles. Particularly in mobile applications, that is to say, above all, in mobile homes or other camping vehicles with the small amount of space available there, the hot water tank can be accommodated with an exact fit in free spaces, and the occurrence of dead unusable spaces is avoided.

In a further advantageous embodiment of the invention, the supporting elements are arranged at least partially on an outer side of the outer container. The supporting elements can consequently be attached at a later stage in a simple way. Moreover, a simple introduction of the pressure forces into the supporting elements is made possible.

In a further advantageous refinement of the invention, the supporting elements are designed at least partially as stamped-out portions of the walls of the outer container. The supporting elements can consequently be produced in a simple way during or after the production of the outer container.

In a further advantageous embodiment of the invention, the inner container consists of a noncorrosive material. It is particularly advantageous if the inner container consists of a high-grade steel. In this case, it is possible that the inner container acquires high corrosion resistance and high mechanical stability.

In a further advantageous embodiment of the invention, the outer container consists of a metal. It is particularly advantageous if the outer container consists of a material which is selected from a group composed of aluminum and aluminum compounds. In this case, it is particularly advantageous that a low specific weight of the material in the outer container and good mechanical stability are afforded. Furthermore, an outer container which is manufactured from materials of this type can be produced particularly cost-effectively.

In a further advantageous embodiment of the invention, the outer container consists of extruded aluminum or an extruded aluminum compound. It is consequently possible, even during the production of the outer container, to integrate built-on parts into the outer container. Such built-on parts may be, for example, supporting elements or holding elements, but also connection pieces for measuring devices.

In a further advantageous embodiment of the invention, the outer container has a first part in the form of a half shell and a second part in the form a half shell. This makes it possible to produce the outer container particularly simply and to assemble the hot water tank in a simple way.

In a further particularly advantageous embodiment of the invention, the heat insulation layer has a polyurethane foam. The heat insulation layer consisting of a polyurethane foam can be produced simply and cost-effectively.

In a further particularly advantageous embodiment of the invention, the heat insulation layer has a synthetic fiber material. The heat insulation layer consisting of a synthetic fiber material can allow good heat insulation along with a high mechanical stability of the heat insulation layer.

According to a second aspect, the invention is distinguished by a method for producing a hot water tank by provision of a first part in the form of a half shell and of a second part in the form of a half shell of the outer container, by application of foamable plastic materials to an inner side of the first part and an inner side of the second part of the outer container, and by introduction of the inner container between the first part in the form of a half shell and the second part in the form of a half shell of the outer container. The method comprises, further, bracing of the inner container with the first part and the second part of the outer container by means of a bracing device and action on the inner container with an internal pressure above atmospheric pressure, until the heat insulation layer is formed by the foaming and curing of the plastic materials between the inner container and the first and second parts in the form of a half shell of the outer container, reduction of the internal pressure in the inner container to ambient pressure, and removal of the bracing device.

Exemplary embodiments of the invention are explained below with reference to the diagrammatic diagrams in which:

figure 1 shows a perspective, partially cutaway view of a hot water tank.

figure 2 shows a longitudinal section through the hot water tank along the line II-II of figure 1 in a first embodiment,

figure 3 shows a cross section through the hot water tank along the line III-III of figure 2 in the first embodiment, and

figure 4 shows a cross section through the hot water tank in a further embodiment.

Elements of identical design or functioning are given the same reference symbols throughout the figures.

Figure 1 shows a perspective view of hot water tank 10 with an outer container 14 in which an inner container 12 is arranged. The outer container 14 has an upper wall 24a and a lower wall 24b, lateral walls 30a, 30b and end walls 32. The walls 24a, 24b, 30a, 30b, 32 of the outer container are of rectangular design here, but may also assume any other desired planar polygonal shapes. In each case two of the walls 24a, 24b, 30a, 30b of the inner container 12 lie opposite one another, but may also be arranged at an oblique angle to one another.

The outer container 14 has on its walls 24a, 24b, 30a, 30b, 32 supporting elements 16, (partially concealed in the figure) which serve for a mechanical stabilization of the hot water tank 10 with respect to fluctuations in the internal pressure.

On the embodiment shown here, the supporting elements 16 on the end walls 32 are designed so as to be raised, while the supporting elements 16 of the walls 24a, 24b, 30a, 30b of the outer container 14 are designed as stamped-out portions of the walls 24a, 24b, 30a, 30b of the outer container 14. In alternative embodiments, however, the supporting elements 16 on the end walls 32 may also be designed as stamped-out portions of the end walls 32 or the supporting elements 16 of the walls 24a, 24b, 30a, 30b may be of raised design.

The hot water tank has a first connection piece 18 and a second connection piece 20. If the hot water tank 10 is used, for example, as a service water tank, then, for example, cold water can be introduced into the hot water tank 10 via the second connection piece 20 and heated-up hot water can be extracted at the first connection piece 18. By contrast, if the hot water tank 10 is used, for example, as a buffer store for a heating system, then hot water heated by a burner (not illustrated) can be introduced into the hot water tank 10 via the first connection piece 18, while cooler water can pass back to the burner, to be heated up, via the second connection piece 20.

A longitudinal section through the hot water tank 10 of figure 1 is illustrated in figure 2 and a cross section through the hot water tank 10 of figure 1 is illustrated in figure 3.

Between the inner container 12 and the outer container 14 a heat insulation layer 26 is arranged. This preferably has a polyurethane foam. Moreover, it is advantageous if the heat insulation layer has synthetic fiber materials which give the heat insulation layer a good heat insulation capacity and high mechanical stability. The heat insulation layer 26 serves for protecting hot water received in the inner container 12 against cooling down with respect to the region surrounding the hot water tank 10.

The inner container 12 has an upper wall 22a, a lower wall 22b, lateral walls 28a, 28b and end walls 31. The walls 22a, 22b, 28a, 28b, 31 of the inner container 12 are rectangular in the embodiment shown here. Further, in each case, two of the walls 22a, 22b, 28a, 28b, of the inner container 12 lie opposite one another. However, the walls 22a, 22b, 28a, 28b of the inner container 12 may assume any other desired polygonal shape and even be arranged at an oblique angle to one another.

The inner container 12 and the outer container 14 preferably consist in each case of a metal.

It is particularly preferred if the inner container 12 consists of a high-grade steel, since in this case a corrosion of the inner container 12 can be counteracted and a high stability of the inner container can be achieved.

The outer container 12 preferably consists of aluminum or of an aluminum compound. In particular, the outer container 14 may be produced from extruded aluminum or an extruded aluminum compound. Extruded components consisting of aluminum or aluminum compounds are particularly advantageous, since in these, for example, the supporting elements 16 designed as stamped-out portions or arranged on a wall 24a, 24b, 30a, 30b, 32 can be formed particularly effectively as integral parts of the walls of the outer container 14. Moreover, these materials are very light, this being particularly advantageous especially in mobile applications.

The hot water tank 10 illustrated in figures 1-3 can be adapted very effectively to various spatial shapes and geometries. If, for example, the hot water tank 10 is to be used in mobile applications, such as in a mobile home or another camping vehicle, then, in particular, the height of the hot water tank 10 can be adapted in such a way that even flat installation spaces, such

as are often available in vehicles of this type, can be utilized for the hot water tank 10.

Figure 4 illustrates a cross section through a further embodiment of the hot water tank 10. The outer container 14 has a first part 34 in the form of a half shell and a second part 36 in the form of a half shell. The first part 34 in the form of a half shell and the second part 36 in the form of a half shell of the outer container 14 are designed such that they can be connected positively to one another by means of connection elements 38. A two-part version of the outer container 14 may be particularly advantageous in the production of the hot water tank 10, as will be shown below.

A method for producing the hot water tank 10 is illustrated in detail below:

First, the first part 34 in the form of a half shell and the second part 36 in the form of a half shell of the outer container 14 are provided. Foamable plastic materials are then applied in each case to an inner side of the first part 34 in the form of a half shell and of the second part 36 in the form of a half shell of the outer container 14.

Subsequently, the inner container 12 is introduced between the first part 34 in the form of a half shell and the second part 36 in the form of a half shell of the outer container 14. This preferably takes place in that the inner container 12 is, for example, first applied to the second part 34 in the form of a half shell and then the first part 36 in the form of a half shell of the outer container 14 is laid over the inner container 12. In a further preferred embodiment, the first part 34 in the form of a half shell and the second part 36 in the form of a half shell of the outer container 14 are first connected to one another, and then the inner container 12 is pushed between the composite structure consisting of the first part 34 in the form of a half shell and second part 36 in the form of a half shell of the outer container 14. The basic shape of the hot water tank 10, as shown in the embodiment of figure 4, is consequently already predetermined.

The inner container 12 is then braced with the first part 34 and the second part 36 of the outer container 14 by means of a bracing device, not shown, and the inner container 12 is acted upon with an internal pressure above atmospheric pressure. Action upon the inner container 12 with an internal pressure above atmospheric pressure is particularly advantageous because

the foamable plastic materials, during foaming, can increase their volume, and this may lead to a deformation of the inner container 12. In an extreme case, it would even be possible for the inner container 12 to be destroyed by one of the walls 22a, 22b, 28a, 28b, 31 of the inner container 12 being pressed in or torn open by the foamable plastic materials.

The heat insulation layer 26 is formed as a result of the foaming and curing of the plastic materials between the inner container 12 and the first and second parts 34, 36 in the form of a half shell of the outer container 14. The inner container 12, the heat insulation layer 26 and the outer container 14 form a sandwich structure. After the foaming and curing of the foamable plastic materials have ended and the heat insulation layer 26 is formed between the inner container 12 and the first and the second part 34, 36 in the form of a half shell of the outer container, the internal pressure in the inner container 12 is reduced to ambient pressure.

Preferably, then, the connection elements 38 can be attached at connection points between the first part 34 in the form of a half shell and the second part 36 in the form of a half shell of the outer container 14, in order to achieve a positive connection between the two parts 34, 36 in the form of a half shell of the outer container 14 and, consequently, a stable mechanical set-up of the hot water tank 10.

Finally, the bracing device is removed from the hot water tank 10.

## Claims

1. A hot water tank (10), with
  - an outer container (14),
  - an inner container (12) which is arranged in the outer container (14) and which serves for the reception of hot water and is spaced apart from the outer container (14), and
  - a heat insulation layer (26) which is arranged between the inner container (12) and the outer container (14),characterized in that the inner container (12) has planar polygonal walls (22a, 22b, 28a, 28b), the outer container (14) has planar polygonal walls (24a, 24b, 30a, 30b), and the planar polygonal walls (22a, 22b, 24a, 24b, 28a, 28b, 30a, 30b) of the inner container (12) and/or of the outer container (14) have supporting elements (16) which are designed such that they counteract an internal pressure of the hot water tank (10) so that the hot water tank (10) preserves its shape.
2. The hot water tank (10) as claimed in claim 1, characterized in that the inner container (12) has at least two polygonal walls (22a, 22b, 28a, 28b) which lie opposite one another and are parallel to one another, and the outer container (14) has at least two polygonal walls (24a, 24b, 30a, 30b) which lie opposite one another and are parallel to one another.
3. The hot water tank (10) as claimed in claim 1 or claim 2, characterized in that the inner container (12) has at least four polygonal walls (22a, 22b, 28a, 28b), of which in each case two lie opposite one another and are parallel to one another, and the outer container (14) has at least four polygonal walls (24a, 24b, 30a, 30b), of which in each case two lie opposite one another and are parallel to one another.
4. The hot water tank (10) as claimed in one of the preceding claims, characterized in that at least two polygonal walls (22a, 22b, 28a, 28b) of the inner container (12) which lie opposite one another are congruent with one another, and at least two polygonal walls (24a, 24b, 30a, 30b) of the outer container (14) which lie opposite one another are congruent with one another.

5. The hot water tank (10) as claimed in one of the preceding claims, characterized in that the polygonal walls (22a, 22b, 24a, 24b, 28a, 28b, 30a, 30b) are rectangular.
6. The hot water tank (10) as claimed in one of the preceding claims, characterized in that the supporting elements (16) are arranged at least partially on one wall of the outer container (14).
7. The hot water tank (10) as claimed in one of the preceding claims, characterized in that the supporting elements (16) are designed at least partially as stamped-out portions of the walls (24a, 24b, 30a, 30b) of the outer container (14).
8. The hot water tank (10) as claimed in one of the preceding claims, characterized in that the inner container (12) consists of a noncorrosive material.
9. The hot water tank (10) as claimed in one of the preceding claims, characterized in that the inner container (12) consists of a high-grade steel.
10. The hot water tank (10) as claimed in one of the preceding claims, characterized in that the outer container (14) consists of a metal.
11. The hot water tank (10) as claimed in one of the preceding claims, characterized in that the outer container (14) consists of a material which is selected from a group composed of aluminum and aluminum compounds.
12. The hot water tank (10) as claimed in one of the preceding claims, characterized in that the outer container (14) consists of extruded aluminum or an extruded aluminum compound.
13. The hot water tank (10) as claimed in one of the preceding claims, characterized in that the outer container (14) has a first part (34) in the form of a half shell and a second part (36) in the form of a half shell.
14. The hot water tank (10) as claimed in one of the preceding claims, characterized in that the heat insulation layer (26) has a polyurethane foam.

15. The hot water tank (10) as claimed in one of the preceding claims, characterized in that the heat insulation layer (26) has a synthetic fiber material.

16. A method for producing a hot water tank (10) as claimed in claim 1, with the following steps:

- provision of a first part (34) in the form of a half shell and of a second part (36) in the form of a half shell of the outer container (14),
- application of foamable plastic materials to an inner side of the first part (34) and an inner side of the second part (36) of the outer container (14),
- introduction of the inner container (12) between the first part (34) in the form of a half shell and the second part (36) in the form of a half shell of the outer container (14),
- bracing of the inner container (12) with the first part (34) and the second part (36) of the outer container (14) by means of a bracing device and action upon the inner container (12) with an internal pressure above atmospheric pressure, until the heat insulation layer (26) is formed by the foaming and curing of the plastic materials between the inner container (12) and the first and second parts (34, 36) in the form of a half shell of the outer container (14),
- reduction of the internal pressure in the inner container (12) to ambient pressure, and
- removal of the bracing device.

