

June 22, 1954

D. W. VAN DOORN
PROCESS AND APPARATUS FOR SEPARATING
TRASH FROM LINT COTTON AND THE LIKE

2,681,476

Filed Sept. 12, 1949

3 Sheets-Sheet 1

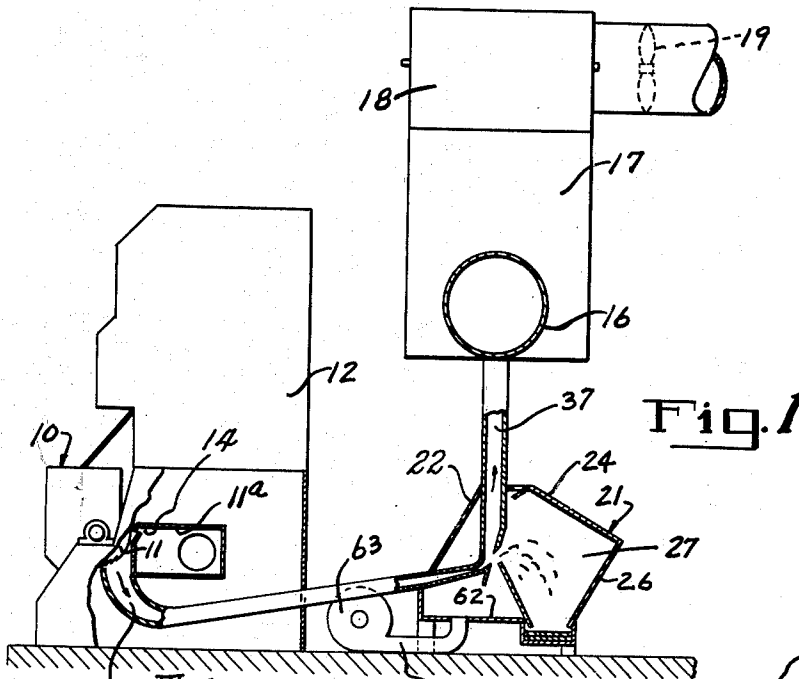

Fig. 1

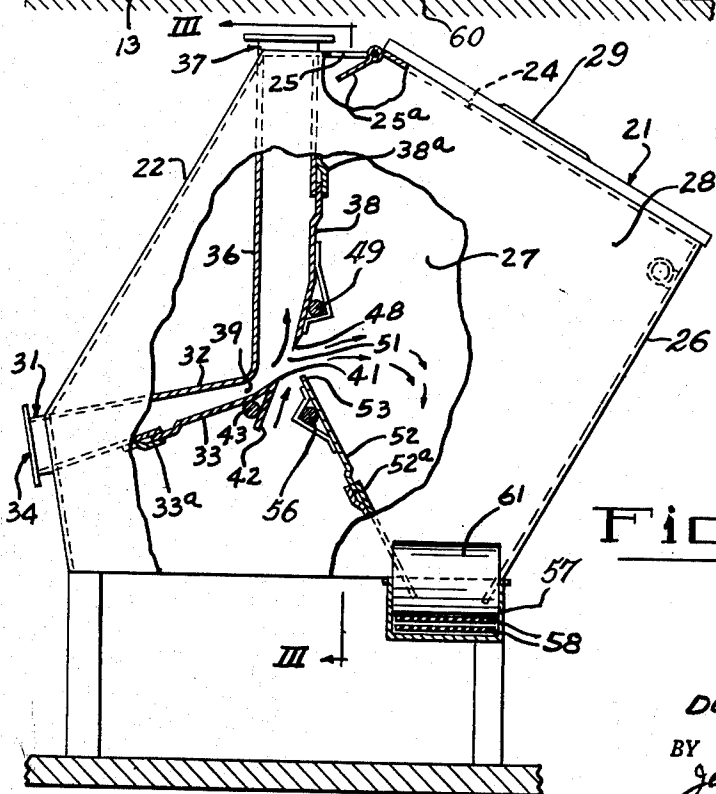

Fig. 2

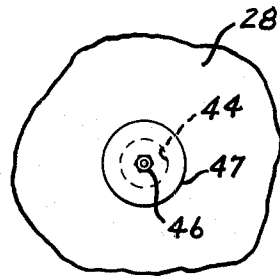

Fig. 4

INVENTOR.
DONALD W. VAN DOORN
BY
Jennings & Carter
ATTORNEYS

June 22, 1954

D. W. VAN DOORN
PROCESS AND APPARATUS FOR SEPARATING
TRASH FROM LINT COTTON AND THE LIKE

2,681,476

Filed Sept. 12, 1949

3 Sheets-Sheet 2

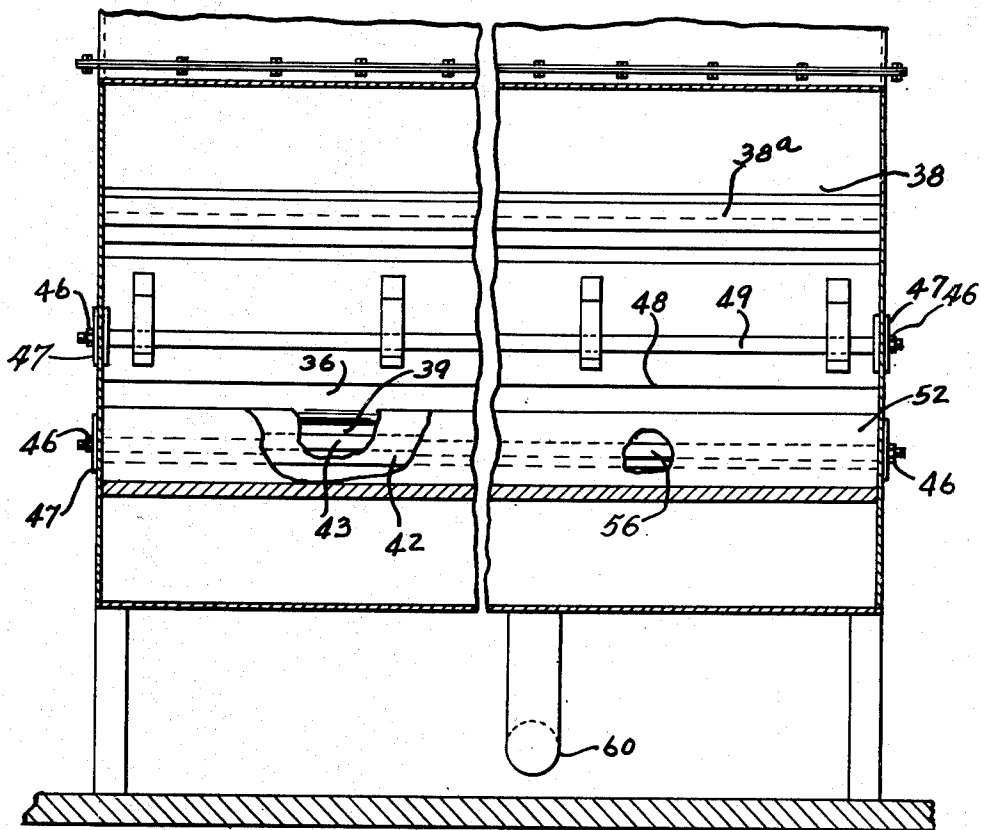

Fig. 3

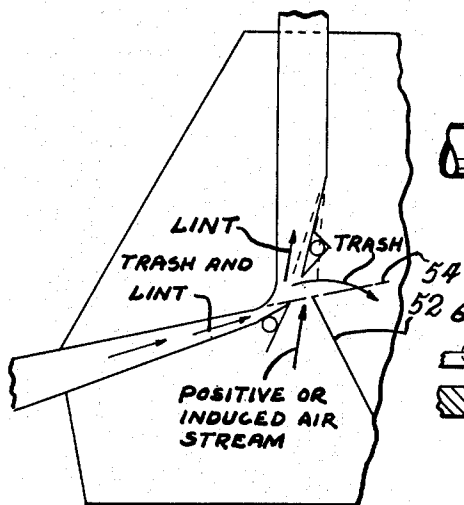

Fig. 6

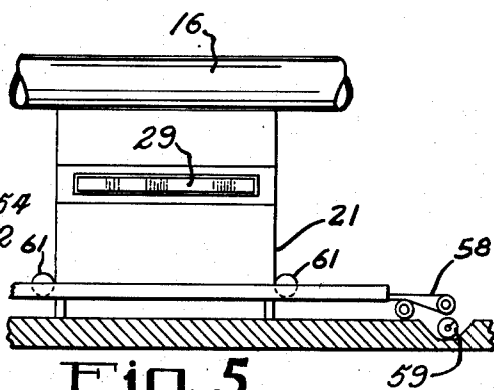

Fig. 5

INVENTOR.
DONALD W. VAN DOORN

BY

Jennings & Carter

ATTORNEYS

June 22, 1954

D. W. VAN DOORN
PROCESS AND APPARATUS FOR SEPARATING
TRASH FROM LINT COTTON AND THE LIKE

2,681,476

Filed Sept. 12, 1949

3 Sheets-Sheet 3

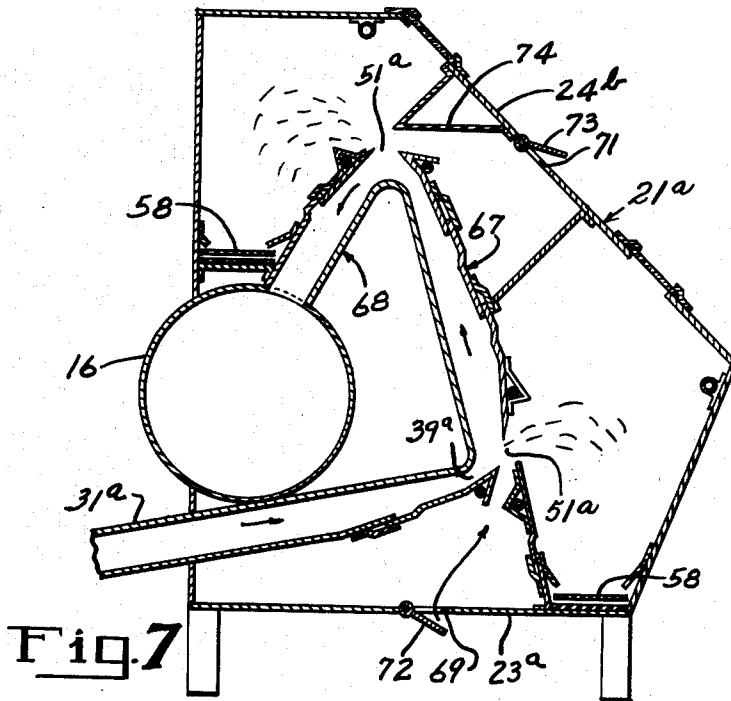

Fig. 7

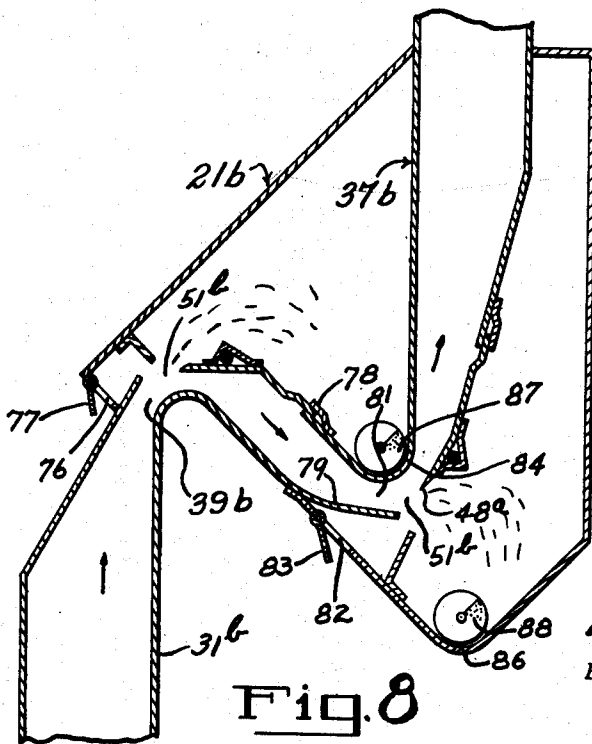

Fig. 8

INVENTOR.
DONALD W. VAN DOORN

BY

Jimmings & Carter

ATTORNEYS

UNITED STATES PATENT OFFICE

2,681,476

PROCESS AND APPARATUS FOR SEPARATING TRASH FROM LINT COTTON AND THE LIKE

Donald W. Van Doorn, Columbus, Ga., assignor to Lummus Cotton Gin Company, a corporation of Georgia

Application September 12, 1949, Serial No. 115,204

20 Claims. (Cl. 19—76)

1

My present invention relates to apparatus for separating from lint cotton trash of the kind usually mixed with the lint cotton as it comes from the gin.

Heretofore in the art to which this invention relates, it has been proposed to utilize the combined effects of centrifugal force and gravity to separate trash from lint cotton while the commingled trash and cotton were air-borne, as for instance while borne along by the air stream in the lint flue. Such method of separation has not proved to be entirely satisfactory. One reason for this appears to be that the specific gravities of the lint and a large part of the trash mixed therewith are approximately the same. Thus, a centrifugal separator capable of discharging such trash also discharges therewith an excessive quantity of lint. Another reason for the lack of success of centrifugal-gravity separators for these materials is that in those types embodying slotted side walls the lint chokes the slots, making the device inoperative after a short period of use. In the mechanical type of cleaners embodying saws and cleaning bars, the saws engage the cotton in such manner as to form snarled or tightly bunched groups of fibers which adversely affect the making of yarn from such lint. Further the mechanical cleaners throw out a high percentage of lint and are expensive of manufacture and operation.

It is the prime object of my invention therefore to effect a greatly improved separation of air-borne trash and lint cotton, and to accomplish this separation with simple apparatus especially adapted for insertion in the lint flue between the gin and condenser.

Another object of my invention is to provide a process for separating trash from fibrous materials such as lint cotton in which a mixture of the fibrous material and trash is impelled at high velocity by means of an air stream toward a trash delivery opening, abruptly changing the direction of said stream at said trash delivery opening, and introducing a stream of clean air at the opening to entrain and carry away substantially the fibrous material only.

A further object of my invention is to provide a process for separating trash from fibrous material in which separation is brought about by differences in momentum of the particles at high velocity, and which no moving parts of apparatus are required to bring about the separation.

Another object of my invention is to provide apparatus of the character designated which will be effective to separate air-borne lint and trash

2

with a minimum amount of power by effecting the separation thereof while the lint and trash are borne by an air stream of relatively small volume and of relatively high velocity, thereby also reducing to some extent the size of the lint conduits, condensers and fans for the system.

Another object is to provide apparatus which shall separate those masses or particles of the lint which are bunched or tightly bound in with trash by the provision of a divider piece having a sharp edge against which such particles impinge, thus to disentangle or separate them, causing the lint to proceed with the lint stream and the trash to follow the trash stream.

Further objects are to provide an opening in the lint flue for discharging the trash, together with adjustable means for varying the size thereof; to provide around the apparatus a housing into which the trash is deposited and having trash removing mechanism therein; and in general to provide apparatus which is particularly free of structural complications and which is simple of installation and operation.

Briefly, I have found that trash may be separated from lint cotton by moving the air-borne commingled mass at a high velocity while in a flue or duct, and subjecting the lint and trash to the action of either a positive or an induced stream of clean air directed angularly toward the path of movement of the commingled lint and trash. In practice I have found that such apparatus, operating at the velocities later to be set out herein, produces a very high percentage of separation. I attribute this in part to the fact that the momentum of the air-borne lint is considerably less than the momentum of the air-borne trash. As will be appreciated, momentum is a function of mass times velocity, and in my invention I utilize the effect of an angularly directed air stream on the lint-trash stream instead of relying solely upon centrifugal action to effect separation. Further, the surface area of the lint in relation to its mass is considerably higher than the surface area-weight relation of the trash. The angularly directed air stream, if its velocity is approximately a certain rate, can be caused to deflect the lint in one direction and yet be ineffective to prevent the trash from continuing substantially along its initial path of movement. Under such conditions the actual separation may be accomplished by simply providing a divider member at the point of departure of the lint from the trash. By observing my improved apparatus in operation, I have discovered that there is in fact a line of demarcation be-

tween the path of movement of the lint and that of the trash. For convenience, I so design the apparatus that the trash is removed at a point of turn or curvature in the duct or flue.

Apparatus illustrating the features of my invention is shown in the accompanying drawings forming a part of this application in which:

Fig. 1 is a side elevational view partly in section of a gin, its associated feeder, and my improved apparatus disposed in the lint flue between the gin and condenser;

Fig. 2 is an enlarged end elevational view of my improved separating apparatus partly broken away and in section;

Fig. 3 is a detailed sectional view taken along line III—III of Fig. 2;

Fig. 4 is a fragmental end elevational view of one of the rods for adjusting the size of the trash opening in the lint flue;

Fig. 5 is a front elevational view of the apparatus shown in Figs. 1 to 4, inclusive;

Fig. 6 is a diagrammatic view illustrating the functioning of my improved apparatus; and,

Figs. 7 and 8 are transverse sectional views illustrating modified apparatus embodying the principles of my invention.

Referring now to the drawings and more particularly to Figs. 1 to 6 inclusive, I show at 10 the usual gin stand embodying a saw cylinder 11. Mounted above the gin in the usual manner is a feeder 12. Adjacent the saw cylinder is an air chamber 11a which supplies air through a doffing nozzle 14 for removing the lint cotton from the saw cylinder 11. Beneath the saw cylinder is a lint duct 13. Lint from the saws is discharged into the lint duct 13 in the manner well understood in the art. While only one gin stand is shown in the drawing, it will later appear that my invention is adapted for association with each gin of a multiple number thereof. Thus, lint from the separate gins 10 is eventually delivered through a system of ducts from the duct 13 to a common lint flue 16. From the lint flue 16 the lint is discharged into a battery condenser if there is more than one gin, or to an individual condenser if that is desirable or in the event there is but a single gin. The condenser 17 is of the usual type, although through the use of my invention it may be smaller than condensers of like capacity heretofore used, and may embody a rotary foraminous drum 18. Air is drawn through the drum 18 and through the lint flue 16 by means of a suction fan indicated diagrammatically at 19.

My invention preferably is associated with a closed housing indicated generally by the numeral 21. As shown in Fig. 2 the housing has a rear wall 22, a front wall embodying sloping sections 24 and 26, and end walls 27 and 28. The housing is provided at its top with an opening 25 under control of a valve 25a. For convenience in inspecting the inside of the housing I may provide a glass window 29 in the section 24 of the front wall. As before stated, I preferably provide a housing 21 together with the mechanism therein presently to be described for each gin.

Within the housing 21, and passing through the rear wall 22 is a duct 31 into which lint from the gin is delivered from the duct or lint flue 13. As best shown in Figs. 2 and 3, the duct 31 comprises an upper wall 32 and a lower wall 33 which converge from the inlet end 34 thereof toward the inner end of the duct. Likewise, the walls 32 and 33 extend the entire length of the housing 21

and the ends thereof are substantially airtight against the end walls 27 and 28.

The upper wall 32 of the duct 31 is continued upwardly to provide a wall 36 forming one wall of a vertical duct 37. The remaining wall of the duct 37 is indicated at 38. The duct 37 likewise is coextensive in length with the inner dimensions of the housing, to correspond with the length of the duct 31.

The walls 33 and 38 are provided with slip connectors 33a and 38a, respectively, whereby the inner ends thereof may be moved axially as will be explained.

As stated the walls 32 and 33 converge toward each other, thus to define between them a relatively narrow throat or passage 39. Likewise, the lower wall 33 terminates at 41 and is provided with a down turned portion 42. Between the portion 42 and the wall proper I provide a rod 43 which extends from end to end of the housing 21 and having threaded ends passing through enlarged openings 44 in the end walls 27 and 28. On the threaded ends of the rod 43 I provide nuts 46, and slidable on the rod on the outside of each of the walls 27 and 28 I provide a disc plate 47. By this means it will be apparent that the width of throat 39 defined between the inner ends of the walls 32 and 33 may be adjustably varied as well as the distance apart of the inner ends of walls 33 and 38. The plates 47 serve to prevent the egress or ingress of air from the housing 21 through the openings 44.

The lower end of the wall 38 terminates at 48, and preferably is substantially knife edged along its entire length. The free end of this wall is supported on a rod 49, similarly mounted in the ends 27 and 28 of the housing 21 as is the rod 43, whereby the end 48 may be moved toward and from the wall 36 and toward and from the end 41 of wall 33. It will thus be apparent that the ends of walls 33 and 38 form between them an elongated opening 51 of adjustable width. This is the opening through which trash is discharged as will later appear. As shown by the dot-dash line 54 in Fig. 6, I prefer to maintain the end 41 of wall 33 on a line which is approximately coincident with the continuation of the inner surface of wall 32. This aids in assuring that trash is directed into opening 51.

Mounted within the housing and extending the length thereof is an inclined wall 52. The upper end of wall 52 is adjustably supported on a rod 56 in the same manner as the rod 43 is supported, and is provided with the slip connector 52a, permitting axial movement of the upper end. The wall 52 slopes downwardly and outwardly and forms with the wall 26 of the housing a hopper like bottom which empties into a trough 57.

Mounted in the trough 57 is a conveyer belt 58. The belt may be supported and driven by suitable means, not shown, and may extend continuously between the housings 21 in the event there is more than one of the same, for instance if there is a battery of gins each equipped with my apparatus. Trash removed from the lint and coming out of the opening 51 falls onto the upper flight of the belt 58, where it is eventually discharged into a common collecting conveyer 59 at the end of the series of housings 21, as is shown in Fig. 5. At the points where the belt 58 enters and leaves the ends of the housing 21 I may seal such openings by means of rollers 61 mounted in the trough 57 and contacting the belt, thereby to maintain the inside of the housing substantially airtight.

From the description just given the operation

5

of my improved lint separator may now be explained and understood. With the gin in operation and with the air chamber 11a supplying doffing air through the nozzle 14, I so regulate the pressure at which the commingled lint and trash enters the duct 31 that there is a pressure of approximately ¼ inch on the water gauge at the inlet of the duct 31. Likewise, I so regulate the fan 19, which as will be remembered exerts suction on the lint flue 16, so that in the vertical duct 37 there is a vacuum of approximately ⅝ inch on the water gauge. Likewise, I adjust the distance between the walls 32 and 33 at the point 39 so that the commingled lint and trash are moving at approximately 3000 feet per minute. Further, I so adjust the free ends of the walls 38 and 33 that the opening of the slot 51 is approximately 1½ inches. In actual practice, I have found that with an 80 saw gin and supplying approximately 1800 cubic feet per minute of air and lint with its impurities to the duct 31 the throat at the point 39 should be approximately ¾ to 1¼ inch when using a vertical duct 37 which is 3 inches in depth. In this instance, the width of the ducts 31 and 37 was 63½ inches, being substantially the length of the doffing nozzle for an 80 saw gin. Under these conditions, I have found that the lint traveling into the duct 31 assumes an upward direction of movement as indicated in Fig. 6 at the point of bend between the ducts 31 and 37. I have further found that under these conditions there is induced into the opening 51 a stream of air which is sufficient to cause the lint to take this upward direction of movement and yet which is insufficient to prevent the trash from continuing its initial direction of movement, thus to be discharged over the top of the wall 52 as indicated by the arrow in Fig. 6. Considering Figs. 2 and 6, it will be seen that the stream of air induced into the opening 51 comes principally from beneath the walls 33 and 52 and strikes the moving lint and trash stream in the duct 31 at an angle. A small amount of air is drawn into the upper part of the housing through the opening 25. This latter amount of air is so regulated by adjusting the damper 25a that a gentle downward flow is produced, and I have found that this reduces turbulence in the housing which might cause some of the very light trash to reenter the opening 51. I have observed that this induced stream of air passing upwardly from beneath walls 33 and 52 is apparently relatively low in volume. However, I have effectively separated a large part of both the heavy and fine trash such as is mixed with cotton during the ginning thereof, and have accomplished this without an increase of power required for a system of comparable ginning capacity. This is accounted for by a reduction in air blast pressure as the suction fan 19 aids in conveying the lint through the system, reducing percentage wise the well known inefficiency of the stream of doffing air as a lint conveying force in the lint flue system.

In lint cotton as it comes from the gin, there are usually bunches or wads of lint, and some lint which is wrapped about particles of trash. I have found that with the apparatus operating under the conditions just set forth, the larger majority of these bunches of lint strike the knife sharp edge 48 of the lower end of the wall 38 and that the effect of this is to strip a large quantity of this lint from the trash or to untangle the same if it is bunched. Further, once the lint is disentangled or disengaged from the foreign

6

matter about which it is wrapped, the lint proceeds up the vertical duct 37 and a large portion of the trash follows the trash stream over the wall 52 and onto the discharge belt 58.

Referring again to Fig. 1, under some conditions I have found it advantageous to provide an air chamber beneath the walls 33 and 52, and supply this chamber with air under pressure, thus to provide a positive instead of an induced stream of air into the opening 51. The chamber is provided by means of a lower wall 62 extending from a side of the trough of the wall 22. A conduit 60 has one end passing through the wall and its opposite end is connected to the discharge side of a blower 63. It will be apparent that with the blower in operation a stream of air is directed upwardly and at an angle to the path of movement of the commingled lint and trash in the duct 31. I have found that this arrangement may be used if more air is necessary than is afforded by induction. Turbulence in the housing is minimized by controlling the opening 25 as already explained.

Referring now particularly to Fig. 7 I show a slightly modified form of my invention in which the duct 31a is provided with the inwardly converging portion in the manner already explained. The adjoining duct 67, corresponding to the vertical duct 37, may be slightly inclined to the vertical. The upper end of the duct 67 is provided with an opening 51a, corresponding to the opening 51, and the lint flue is continued as indicated at 68 to connect with the main lint flue 16. Likewise, one of the trash openings 51a is provided at the inner end of the duct 31a.

The mechanism just described is all enclosed within a housing 21a. For the purpose of permitting a more pronounced induced stream of air to pass into the openings 51a I may provide openings in the lower wall 23a and front wall 24b as indicated at 69 and 71, respectively. These openings are under control of dampers 72 and 73, respectively. In order to more accurately direct the induced stream of air adjacent the uppermost opening 51a, I may provide a triangular shaped deflecting wall 74 with its lower portion extending substantially over the uppermost opening 51a. This arrangement provides in effect two of the separating units enclosed within a single housing, and provides an extremely compact arrangement capable of subjecting the lint to two separating operations. The trash removed from the respective separators may be taken from the housing by means of the conveyer belts 58. Also, I may use the rollers 61 at the ends of the housing to seal the same at the points of ingress and egress of the belt 58. The dampers 72 and 73 are adjusted so that the desired amount of air is induced into each of the openings 51a.

In operation, this apparatus functions in the manner already explained in connection with the first described modification, the trash coming out of the two openings 51a, and the lint remaining in the ducts 67 and 68. This construction also embodies the sharpened edge on the wall 67, similar to the edge 48.

Referring now to Fig. 8, I show a still further modified form of my invention in which the commingled trash and lint is introduced into the housing of the apparatus through a vertically disposed inlet duct 31b. Similarly to the ducts 31 and 31a, the inner end of this duct is contracted to provide a relatively narrow throat 39b. In the wall of the housing 21b, adjacent the throat and end of the nozzle 31b I provide an

opening 76 which is adjustably controlled by means of a damper 77. By suitably adjusting this damper it will be apparent that the induced stream of air passing over the opening 51b adjacent thereto may be controlled.

The lint duct continues downwardly as indicated generally by the numeral 78 and may be provided with a curved baffle 79 providing a constricted passage or throat indicated at 81. Beneath the curved plate 79 I provide another opening 82 in the wall of the housing under control of a damper 83.

The vertically extending duct 37b is provided with the sharpened lower edge 48a, and this edge defines with the inner end of the curved plate 79 an opening 51b. It will thus be apparent that a stream of air induced through the opening 82 strikes the moving lint and trash stream at an angle, causing the lint to go upwardly into the duct 37b and permitting trash to fall into the two hopper bottoms 84 and 86 provided as indicated to the housing 21b. The trash may be removed from the housing by means of a pair of continuous flight conveyers 87 and 88 suitably mounted in the hopper like bottom portions thereof.

From the foregoing it will be apparent that the modified devices just described function substantially identically in principle with that described in connection with Figs. 1 to 6, inclusive. With these modifications I likewise prefer to introduce the commingled lint and trash into the ducts 31a and 31b under a positive pressure of around $\frac{1}{4}$ inch on the water gauge, and to operate with the discharge ducts 68 and 37b, under approximately $\frac{5}{16}$ inch vacuum on the water gauge. Also, the relative sizes of the throats 39a and the throat at the upper end of the duct 67 as well as the throat 39b and the throat at the lower end of the duct 37b are substantially the size already mentioned, namely, in the neighborhood of $\frac{3}{4}$ to $1\frac{1}{4}$ inch, when operating with approximately 1800 cubic feet per minute of air, lint and trash. The width of the various openings 51a and 51b are maintained substantially at $1\frac{1}{2}$ inches. The walls of the ducts are adjustable longitudinally by means of the slip connectors shown. It will be apparent that with the use of the modifications shown in Figs. 7 and 8 the lint is subjected to a pair of cleaning actions, and I have found that with some types of cotton, particularly that which has been machine picked, this dual cleaning action aids in obtaining a more clean and trash free sample. The sharpened edges on the walls adjacent the openings, similar to the edge 48, are positioned so that the bunched or knotted lint strikes the same, thus to disengage therefrom commingled trash or separate the fibers in the manner explained.

From the foregoing it will be apparent that I have devised an improved separating mechanism for separating trash from air-borne lint cotton and the like which is simple of construction and operation and which is entirely effective for its intended purposes. I again wish to point out that this invention does not rely for its operation upon the principles of centrifugal force and gravity. Instead, it relies upon the principle of moving the commingled lint and trash along a given line and subjecting this moving stream to the action of an angularly disposed stream of positively moved or induced air. The physical separation of the two streams is accomplished with a divider piece which is disposed at the point of departure of the lint from the trash. While in

the drawings I have shown the trash opening disposed at a turn or bend in the lint flue, it will be apparent that other methods may be devised for effecting separation of the trash from the lint without changing the direction of the lint flue. Likewise, while I have shown and described my invention as associated with a cotton gin embodying an air doffing mechanism, it will be apparent that it is equally applicable for use with a gin embodying other forms of doffing means such for instance, as a brush cylinder.

I have stated herein that I prefer to move the commingled lint and trash at a velocity of above 3,000 feet per minute. While theoretically there may be no practical upper limit to this velocity at which my device will operate satisfactorily, there are practical limitations on the upper range of such velocity. Among these are the increase in turbulence causing some of the lighter trash to reenter the trash discharge opening, the increase in horsepower, the bad effects of too high a vacuum on the usual commercial condenser, and back lashing of the gin. Therefore, taking all of these matters into account I have found that the practical upper limit of such velocity is in the neighborhood of 5500 feet per minute, and the optimum velocity is in the range of 3000 to 4000 feet per minute.

In stating that the clean air is directed "angularly" against the commingled lint and trash, it will be understood that such expression includes directing a stream of clean air into the moving stream of lint and trash in a direction substantially opposite the direction of movement of the lint and trash.

While I have shown my invention in several forms, it will be obvious to those skilled in the art that it is not so limited, but is susceptible of various other changes and modifications, without departing from the spirit thereof, and I desire, therefore, that only such limitations shall be placed thereupon as are specifically set forth in the appended claims.

What I claim is:

1. The combination with a cotton gin having a saw cylinder and a lint doffing means associated with the saw cylinder together with a lint condenser and a lint flue connecting the gin and the condenser, of apparatus for separating trash from the lint delivered from said gin comprising a housing surrounding a portion of the lint flue at a point between the gin and condenser, there being an opening in the lint flue at a point thereon in the housing through which trash is discharged, a constricted passage in said lint flue immediately adjacent the opening toward the gin, means to maintain the portion of the lint flue connected to the gin under super atmospheric pneumatic pressure, means to maintain that portion of the lint flue leading to the condenser under subatmospheric pneumatic pressure, a wall having one end disposed adjacent the edge of said opening in the lint flue nearest the gin and spaced from said edge to define therewith an opening for the admission of an air stream into the opening in the lint flue, and means to convey from the housing trash discharged from the lint flue opening over said wall.

2. The combination set forth in claim 1 in which the housing is provided with an opening for the admission thereto of air, said opening being located on the side of said housing toward which trash is discharged from said trash opening.

3. The combination with a cotton gin having

an elongated lint flue into which cotton and commingled trash are delivered together with a condenser, of apparatus for separating trash from the lint before the lint reaches the condenser comprising a housing into which the elongated flue projects, a second lint flue of a width equal substantially to the width of the first flue disposed in the housing angularly with respect to the first flue and having its intake end adjacent the inner end of the first flue and leading to the condenser, the walls of said lint flues which subtend the greater angle therebetween stopping short of each other to define between the ends thereof a trash discharge opening communicating with the inside of the housing, a constricted passage in the first flue adjacent said trash discharge opening, a wall in the housing defining with the second lint flue and the housing a substantially closed chamber and having its upper end terminating out of alignment with the projected paths of lint and trash in said first lint flue, the upper end of said wall defining with the inner end of the first lint flue an opening for directing a stream of air into said trash opening and angularly against the trash moving therethrough, and means for removing trash from said chamber.

4. The combination set forth in claim 3 in which the size of said constricted passage and said trash discharge openings are adjustable.

5. The combination set forth in claim 3, in which the edge of the wall of said second flue defining the trash discharge opening is sharpened.

6. The combination set forth in claim 3 in which means are provided to maintain the entrance portion of the first flue under pneumatic superatmospheric pressure and in which means are provided to maintain the second flue under subatmospheric pneumatic pressure.

7. In apparatus for separating trash from lint cotton while the same are dispersed in a moving stream of air, an elongated relatively wide shallow flue having an inlet section into which the air-borne lint and trash are introduced, the discharge end of said section being of less depth than the intake end thereof thereby to define a constricted passage at its discharge end, an outlet section angularly disposed with respect to the inlet section and joined to the discharge end of the inlet section, an opening defined between the walls of said sections at the meeting point of the ends thereof and lying substantially in alignment with the paths of movement of lint and trash in the inlet section, a housing surrounding the sections and having end walls forming end walls for the sections, another wall in said housing of a width equal substantially to the width of said sections and having its upper end spaced from the discharge end of the inlet section to define therewith an opening immediately adjacent the first named opening, the upper end of said other wall terminating out of alignment with the trash discharged from the first opening, and means to remove trash from the housing discharged from the first opening.

8. In apparatus for separating trash from an air borne stream of commingled fibrous material and trash, a duct of substantially constant width and whose depth is a minor fraction of its width and having inlet and outlet sections joined together at an angle to each other and a relatively narrow trash outlet opening to the atmosphere at the juncture of the said sections in the outer wall of the duct substantially in the path of movement of the air borne stream in the inlet

section and extending substantially the width of the duct, a restricted passage in the inlet section of the duct adjacent the trash outlet opening, means for impelling an air-borne stream of fibrous material and trash at a velocity in excess of 3000 feet per minute through said restricted passage, and suction means connected to the outlet section, whereby a stream of air is drawn into the trash outlet opening to deflect the fibrous material while moving at said velocity into the outlet section.

9. Apparatus as defined in claim 8 in which the wall of the inlet section of the duct adjacent the trash outlet opening is curved inwardly of the duct where it forms the restricted passage whereby to cause the stream of lint cotton and trash to hug said wall and form a thin ribbon of material adjacent said outlet opening.

10. In apparatus for separating trash from an airborne stream of commingled lint cotton and trash, a duct of substantial width and whose depth is a minor fraction of its width and having inlet and outlet sections joined together and disposed at an angle to each other and having a relatively narrow trash outlet in the outer wall thereof at the juncture of said sections substantially in line with the path of movement of the lint cotton and trash approaching said trash outlet and extending substantially the entire width of said duct, a restricted passage in the inlet section of the duct adjacent said trash outlet, means to introduce an airborne stream of commingled lint cotton and trash into the inlet section of said duct at super-atmospheric pressure, means to maintain the outlet section of said duct at sub-atmospheric pressure, and means to admit air into said duct through the trash outlet counter to trash being ejected to entrain the lint into the outlet section of said duct, whereby the lint is deflected into the outlet section without being discharged from the duct.

11. Apparatus as set forth in claim 10 in which the duct is mounted in a housing having an opening at the top over the trash outlet to introduce air at atmospheric pressure for admission into the outlet.

12. In apparatus for separating trash from an air-borne stream of fibrous material and trash, a duct of substantial width and whose depth is a minor fraction of its width and having inlet and outlet sections joined together and disposed at an abrupt angle relative to each other and having an elongated trash discharge slot located immediately adjacent the juncture of the inlet and outlet sections in the outer wall of the duct substantially in line with the path of movement of the air-borne stream, means to introduce air-borne fibrous material and trash into the inlet section under super-atmospheric pressure, a restricted passage in the inlet section of the duct adjacent the trash discharge slot whereby to increase the velocity of the stream and reduce its pressure adjacent said slot, means to introduce air into said trash discharge slot in a direction counter to the outward movement of trash to entrain the fibrous material into the outlet section, means to maintain the outlet section under sub-atmospheric pressure, a relatively sharp edged member on the outlet section forming the edge of the discharge slot and means to vary the position of said sharp edged member.

13. In apparatus for separating trash from an air-borne stream of fibrous material and trash, a duct of substantial width and whose depth is a minor fraction of its width and having inlet

and outlet sections joined together and angularly disposed relative to each other and having a narrow elongated trash discharge slot at the juncture of the inlet and outlet sections in the outer wall of the duct substantially in line with the inlet section, means to introduce air-borne fibrous material and trash into the inlet section under super-atmospheric pressure a restricted passage in the inlet section of the duct adjacent the trash discharge slot whereby to increase the velocity of the stream and reduce its pressure adjacent said slot, means to introduce air into said trash discharge slot in a direction counter to the outward movement of trash to entrain the fibrous material into the outlet section, and suction means to reduce the pressure in said outlet section to sub-atmospheric.

14. Apparatus as defined in claim 13 in which the wall of the inlet section of the duct containing said trash discharge slot is curved inwardly as it approaches the slot whereby to cause the commingled fibrous material and trash to hug said wall as it approaches the slot.

15. In apparatus for separating trash from an air-borne stream of lint cotton and trash, a duct of substantial width and whose depth is a minor fraction of its width and having inlet and outlet sections angularly disposed relative to each other and having an elongated trash discharge slot at the juncture of the inlet and outlet sections in the outer wall of the duct substantially in line with the inlet section, means to introduce a stream of air-borne lint and trash into the inlet section under super-atmospheric pressure, means to maintain the stream in the outlet section of said duct under sub-atmospheric pressure, a restricted passage in the inlet section of the duct adjacent the trash discharge slot whereby to increase the velocity of the stream and reduce its pressure adjacent said slot, a divider member mounted on the wall of the outlet section adjacent said slot, means to adjust the position of the divider member whereby to vary the width of the trash discharge slot, and means to introduce air into said trash discharge slot in a direction counter to the outward movement of trash to entrain substantially the lint only into the outlet section.

16. In the separation of trash from an air-borne stream of fibrous material, the process which includes impelling a high velocity stream of air conveying fibrous material and trash toward a trash delivery opening by means of air at super-atmospheric pressure, increasing its velocity and decreasing its pressure to sub-atmospheric prior to reaching said trash delivery opening, abruptly changing the direction of said high velocity air stream at said trash delivery opening, and intersecting said stream at the trash delivery opening with a second stream of air to entrain substantially the fibrous material only into the first mentioned air stream, and carrying the fibrous material away with the said first mentioned stream of air at sub-atmospheric pressure.

17. The process of separating trash and fibrous material which includes impelling a high velocity uniformly wide shallow continuous air stream bearing trash and fibrous material, decreasing the depth of the stream to increase its velocity to a velocity in excess of 3000 feet per minute, directing the stream toward a trash delivery opening, abruptly changing the direction of said

stream at said opening, introducing a second stream of air at substantially atmospheric pressure into said first mentioned stream to entrain substantially the lint cotton only into the said first mentioned air stream, and carrying the lint away with the said first mentioned stream of air at sub-atmospheric pressure.

18. The process of separating trash and lint cotton which includes maintaining a continuous wide shallow confined stream of air bearing trash and lint cotton at a velocity of more than 3000 feet per minute, abruptly changing the direction of movement of said stream while moving at said velocity and substantially simultaneously therewith discharging the trash from said stream into the open, intersecting said stream of lint cotton and trash at said place of change of direction with a second stream of air to entrain the lint cotton only into the first mentioned air stream, and carrying the lint away with the said first mentioned air stream at sub-atmospheric pressure.

19. The process of separating trash from lint cotton which includes impelling a stream of trashy lint cotton through a confined wide shallow path to a trash discharge opening by means of a stream of air at super-atmospheric pressure, increasing the velocity of the stream of air in the path ahead of the point of trash discharge, abruptly changing the direction of said stream of air at said discharge opening, changing the pressure of the stream to sub-atmospheric adjacent the place of change of direction thereof, maintaining the pressure of the stream at sub-atmospheric, and introducing more air at substantially atmospheric pressure into said stream at said discharge opening in a direction counter to the trash being discharged to entrain the lint only into the subatmospheric stream.

20. The process of separating trash from a moving stream of air bearing commingled lint cotton and trash which comprises introducing the stream into a wide shallow duct having an abrupt turn therein intermediate its ends and also having a trash discharge slot therein coextensive in length with the width of the duct and lying in the path of the stream adjacent the turn, moving the commingled stream along in the duct ahead of the trash discharge slot at a velocity above 3000 feet per minute, decreasing the depth of the stream as it nears the slot while maintaining the same substantially at its original width, confining the stream to said duct, and introducing a second stream of clean air into the first mentioned stream through the slot to engage and turn substantially only the lint cotton, thereby to prevent the discharge from the slot.

References Cited in the file of this patent
UNITED STATES PATENTS

Number	Name	Date
233,847	Groom	Nov. 2, 1880
469,559	Groom	Feb. 23, 1892
633,383	Kramer	Sept. 19, 1899
1,023,750	Morscher	Apr. 16, 1912
1,159,168	Broome	Nov. 2, 1915
1,444,516	Moss	Feb. 6, 1923
1,660,682	Stebbins	Feb. 28, 1928
1,713,371	Brennen	May 14, 1929
2,300,978	Sheppard	Nov. 3, 1942
2,372,796	Rogers et al.	Apr. 3, 1945
2,438,047	Graebe	Mar. 16, 1948