



US 20040120763A1

(19) **United States**

(12) **Patent Application Publication**

**Van Cauwenbergh**

(10) **Pub. No.: US 2004/0120763 A1**

(43) **Pub. Date: Jun. 24, 2004**

(54) **STONE FOR FORMING A PAVEMENT**

(30) **Foreign Application Priority Data**

(76) **Inventor: Luc Van Cauwenbergh, Duffel (BE)**

May 24, 2001 (BE)..... 20010350

Correspondence Address:  
**BACON & THOMAS, PLLC**  
**625 SLATERS LANE**  
**FOURTH FLOOR**  
**ALEXANDRIA, VA 22314**

**Publication Classification**

(51) **Int. Cl.<sup>7</sup> .....** E01C 5/00

(52) **U.S. Cl. ....** 404/34

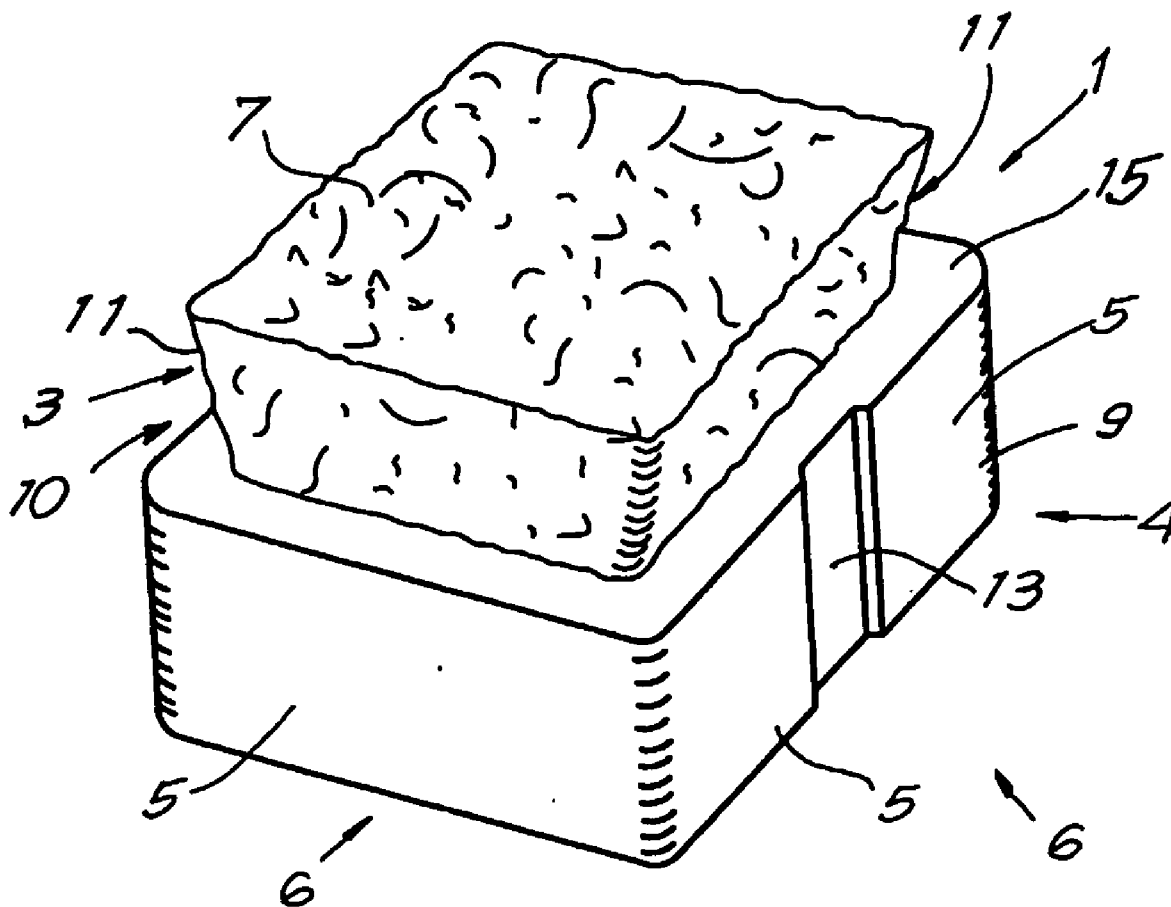
(57) **ABSTRACT**

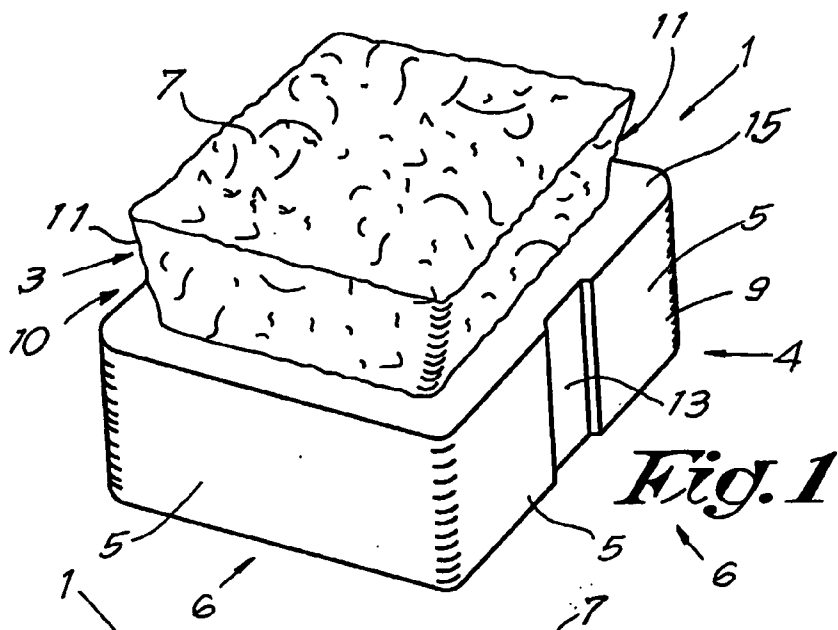
Stone for forming a pavement, characterized in that it has, on one hand, an irregularly or particularly shaped upper portion (3) and, on the other hand, is provided with means (4) which allow to lay such stone (1), together with other, similar stones (1), in a regular manner.

(21) **Appl. No.: 10/475,843**

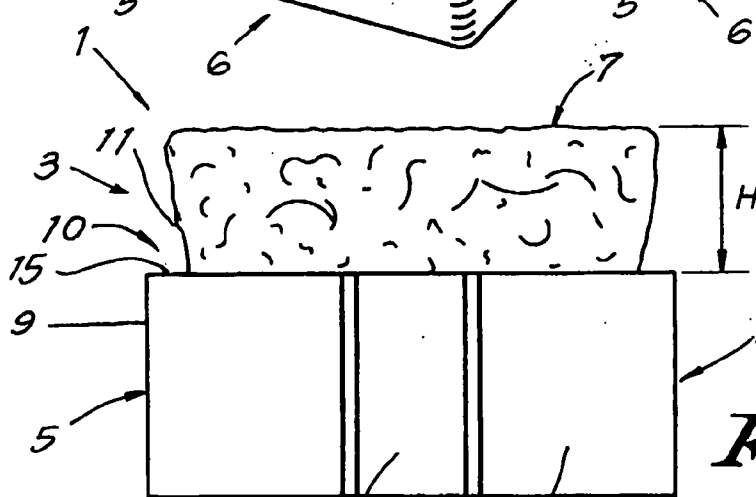
(22) **PCT Filed: Apr. 18, 2002**

(86) **PCT No.: PCT/BE02/00054**

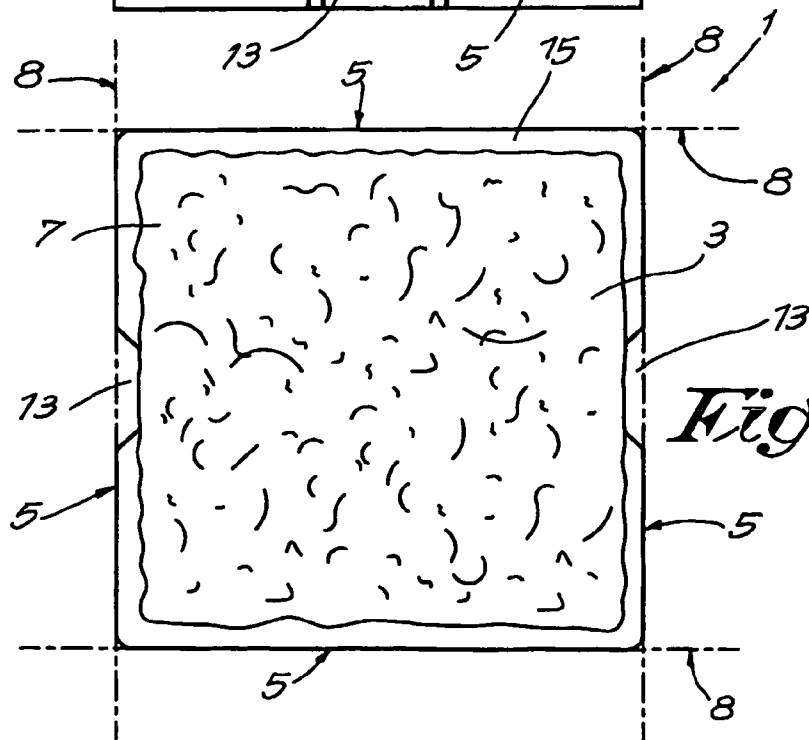




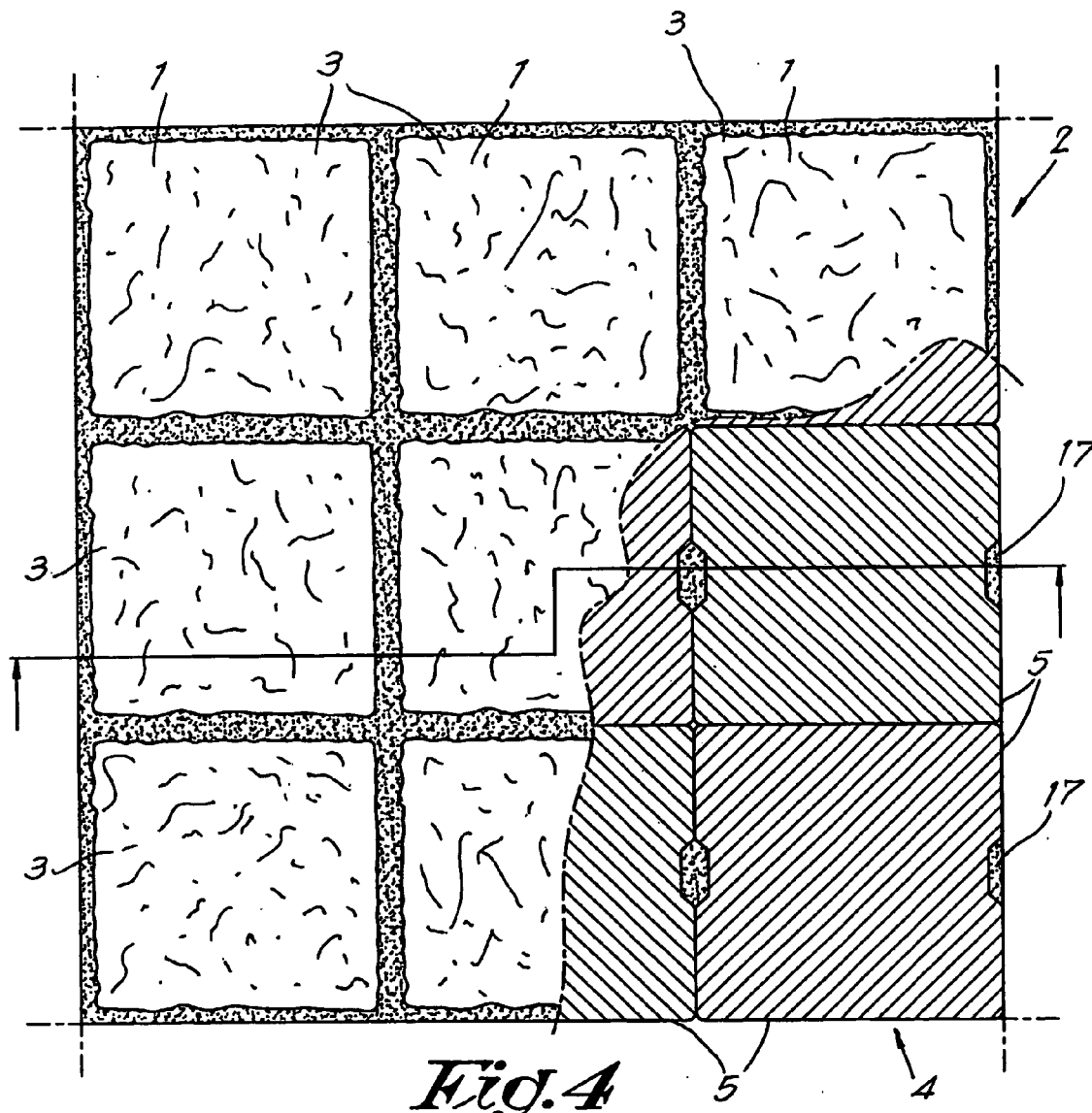
*Fig. 1*



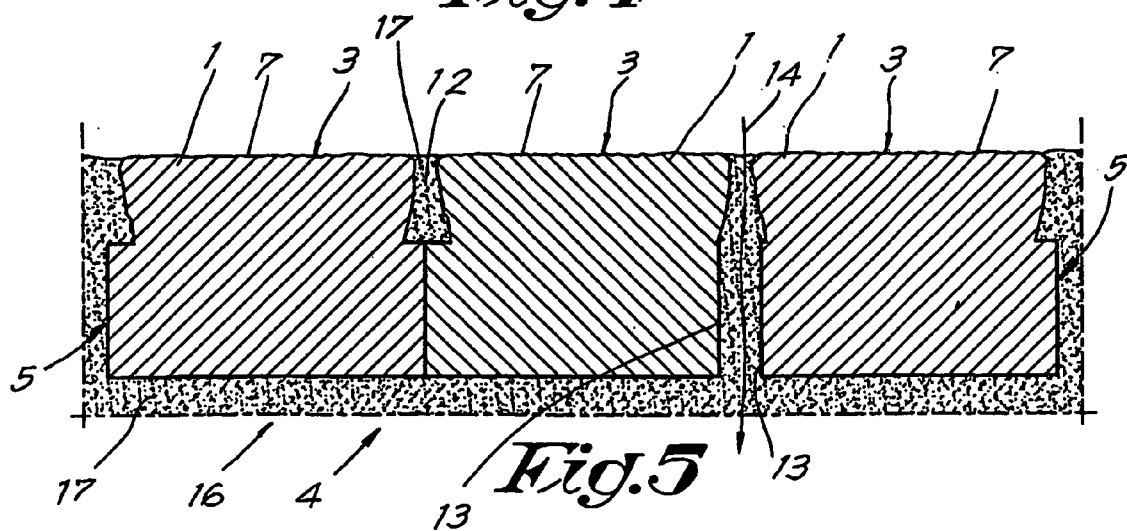
*Fig. 2*



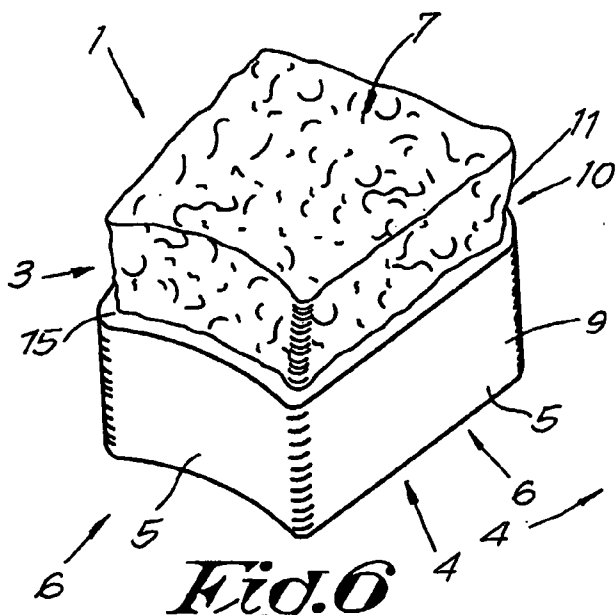
*Fig. 3*



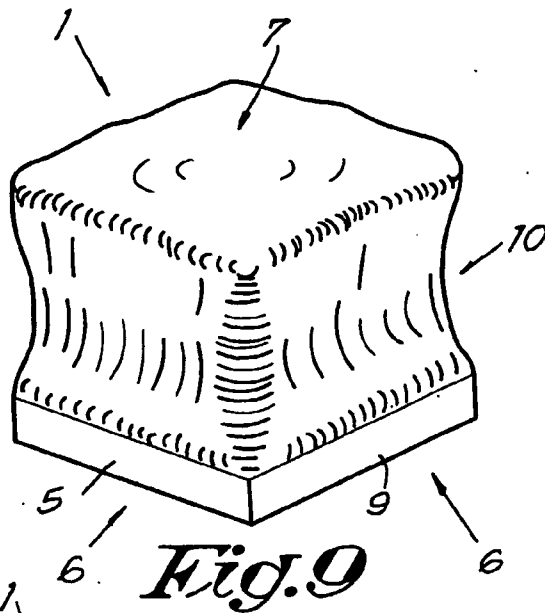
*Fig. 4*



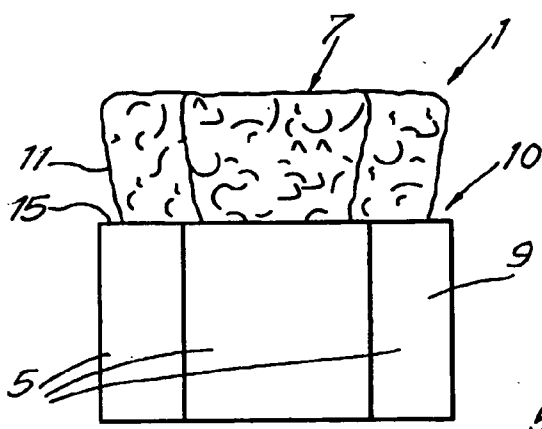
*Fig. 5*



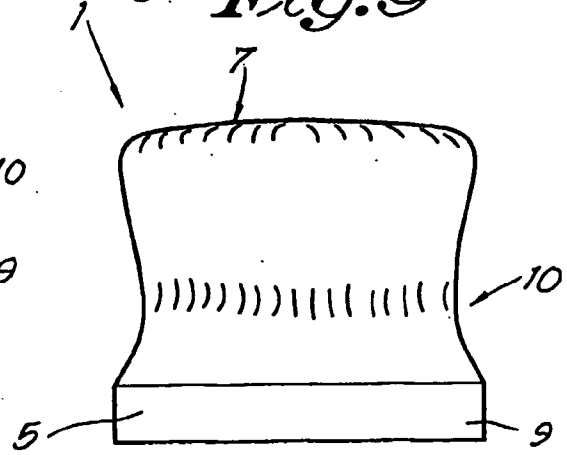
**Fig. 6**



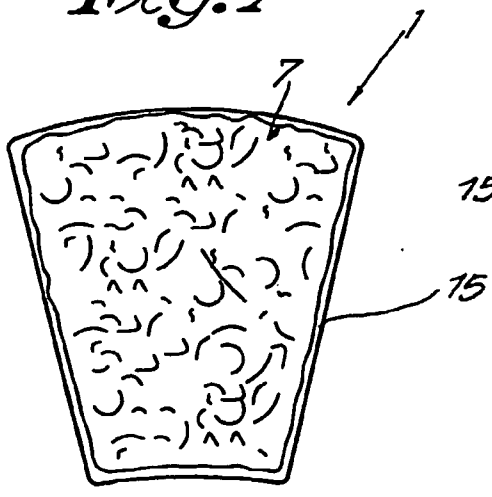
**Fig. 9**



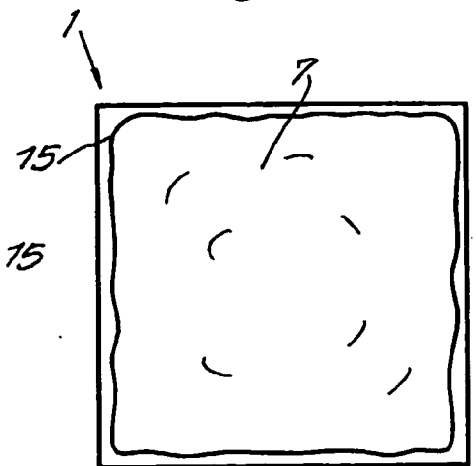
**Fig. 7**



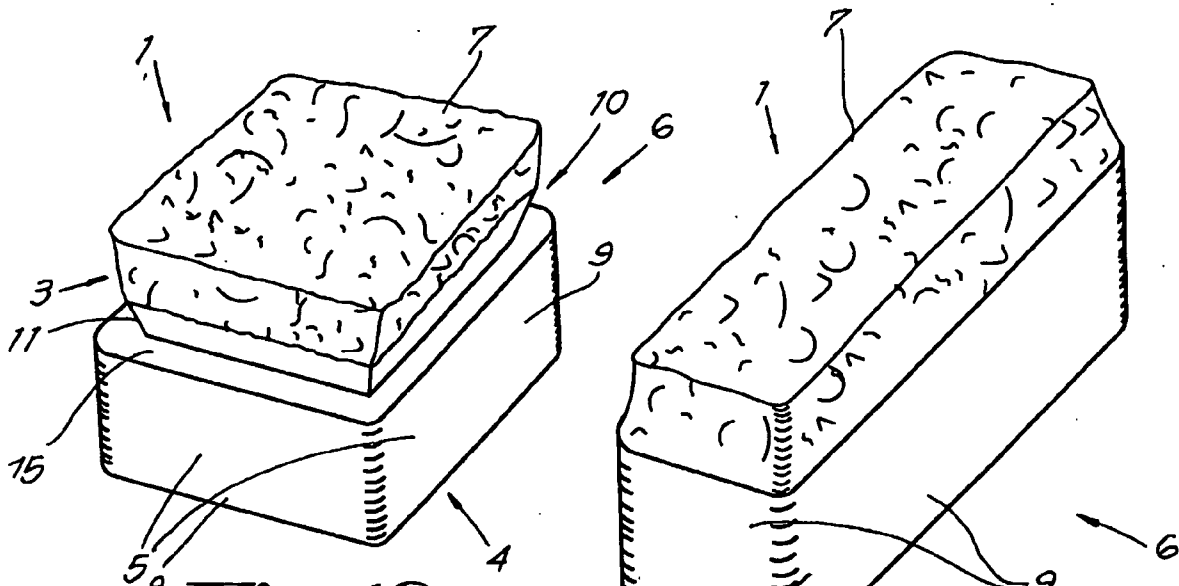
**Fig. 10**



**Fig. 8**

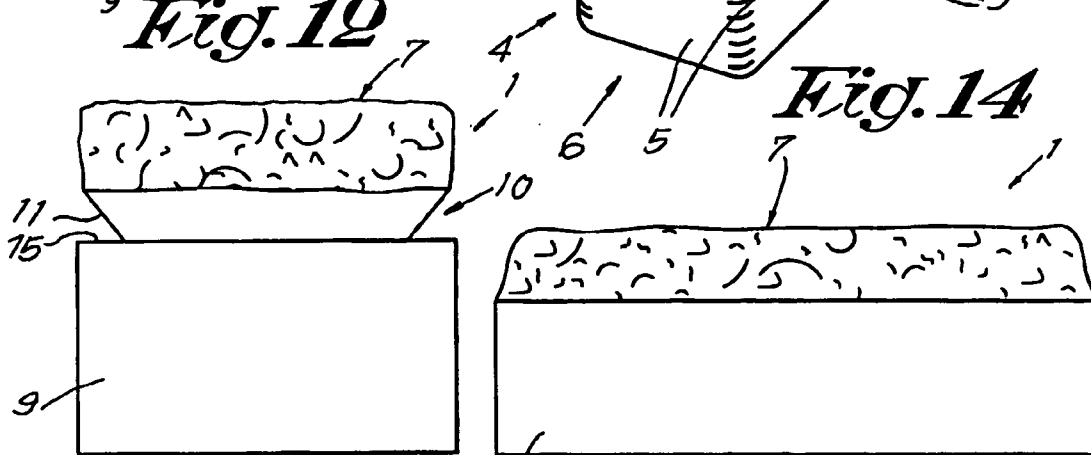


**Fig. 11**



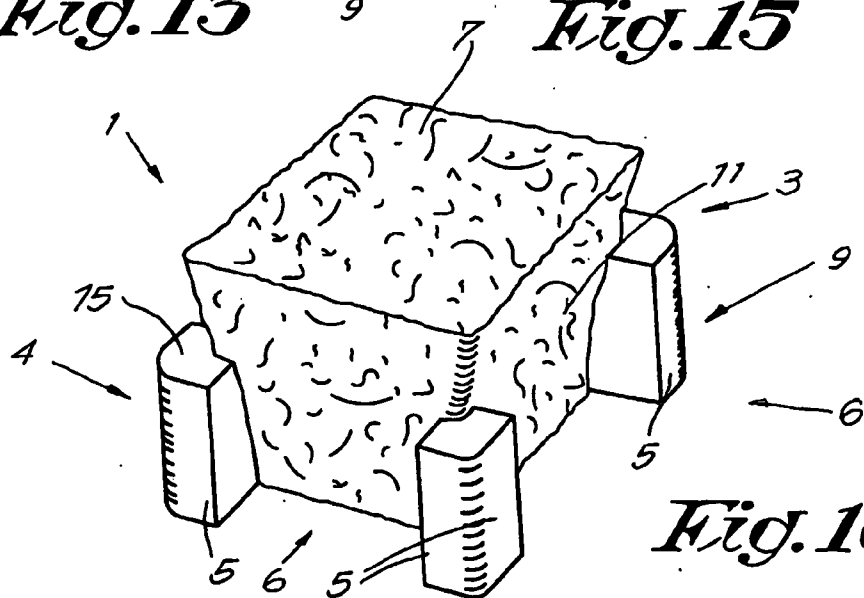
**Fig. 12**

**Fig. 14**



**Fig. 13**

**Fig. 15**



**Fig. 16**

**STONE FOR FORMING A PAVEMENT**

[0001] This invention relates to a stone for forming a pavement.

[0002] By "pavement", herein each ground covering by means of stones is intended, whether public works are concerned for forming, for example, streets and places, or applications in the private sector, for example, for constructing driveways, terraces or the like. Also, it is not excluded to apply such pavement in roofed rooms.

[0003] In first instance, the invention relates to concrete stones, either poured concrete stones, or vibrated concrete stones, however, more in general it may also be applied with stones made of other basic materials.

[0004] It is known that such pavement can be realized with natural stones, such as cobblestones. Due to the irregular shape of such cobblestones, they show the disadvantage that they are more difficult to lay than stones with a regular shape, and that consequently the persons who have to perform the paving, must have good skills in order to lay such cobblestones in good order.

[0005] It is also known that such pavements can be made of classic concrete stones, more particularly clinkers, which, as known, show a regular shape. An advantage of such clinkers consists in that herewith, a pavement can easily be realized, simply by placing them onto a prepared sublayer, for example, a flat sand bed, next to each other and in contact with each other. A disadvantage, however, consists in that with such clinkers no pavement having a natural appearance can be realized.

[0006] According to a first aspect, the invention aims at a stone which, on one hand, may show an irregularly or particularly formed appearance at the upper side, for example, has an irregular shape which is an imitation of natural stone, and, on the other hand, can be laid as easily as regularly shaped clinkers, such that, to this end, no experienced and specialized person skilled in the art is necessary.

[0007] To this aim, the invention relates to a stone for forming a pavement, with as a characteristic that, on one hand, it has an irregularly or particularly formed upper portion and, on the other hand, is provided with means for laying such stone, together with other similar stones, in a regular manner. The laying of the stones then is determined by means of said means and not by the irregularly or particularly formed upper portion, such that, due to an appropriate design of these means, the stones still can be laid orderly against each other in a simple manner.

[0008] Preferably, said means consist of contact portions situated at the side of the stone, lower than the upper side of the stone, which portions determine a regular contour. Thereby, the stones, during laying, simply can be provided with these contact portions adjacent to each other, as a result of which always an exact mutual positioning of the stones can be realized, without any particular skill being required.

[0009] Practically, seen in top view, the contour of said irregularly shaped upper portion will be situated within said regular contour. In this manner, the stones always can be laid with their lowermost, regularly shaped portions against each other in an orderly manner, without thereby being hampered by the irregular design at the upper portions.

[0010] In the most preferred form of embodiment, said means consist of a regularly shaped portion which is situated beneath said irregularly shaped upper portion and, more particularly, is realized in the shape of a base.

[0011] As a consequence of the abovesaid, the stone preferably also has an upper portion, more particularly said irregularly shaped portion, which recedes laterally in respect to the portion situated therebeneath, in such a manner that, when laying this stone against similar stones, a joint is created next to the upper portions of these stones which is suitable for being filled by a filling agent, such as sand or another filling mortar. As a result, the regularly shaped lower portion is hidden from view by the filled joints. Also, the impression is created that the stones are lying loose from each other, whereas in reality they still are fixedly positioned against each other; as a result of which a mutual shifting is excluded.

[0012] The receding portion preferably has an undercut, with as an advantage that the filling agent provided in said joint will be better retained.

[0013] More particularly, it is preferred that the undercut is realized such that, when laying such stone together with similar stones, so to speak, a reversed wedge-shaped joint opening is created, as a result of which a filling agent, for example, sand, or even a hardening filling mortar, provided therein is retained particularly well in this joint opening.

[0014] In a particular form of embodiment, the stone is provided at its side with portions which, when several of such stones are laid against each other laterally, guarantee for a passage for water, which portions, seen from the top downwards, start below the irregularly shaped portion and/or from the lower edge of the receding part. As this portion only starts at a distance below the upper surface of the stones and the portion thereabove is intended for being filled with sand or such, the portions which have to guarantee the passage for water always are hidden from view, with as an advantage that these portions do not form a disturbing factor in the appearance of the obtained pavement surface, which indeed would be the case if such portions specifically should extend up to into the visible upper surface of the stone.

[0015] In a practical form of embodiment, the portions forming a passage for the water will consist of one or more grooves which are formed in one or more sides of said base.

[0016] It is noted that the application of a receding portion, such that a joint is created which can be filled with sand or another filling mortar, also can be advantageous in combination with embodiments of stones, the upper portion of which not necessarily, as aforementioned, has an irregular or special shape.

[0017] According to a second aspect of the invention, the invention thus also relates to a stone for forming a pavement, with as a characteristic that it comprises an upper portion with such a contour that along the side of the upper portion, in respect to the contour formed by the portion situated therebeneath, a receding portion is formed, such that, when laying this stone against similar stones, a joint is created next to the upper portions of these stones which is suitable for being filled with a filling agent. Hereby, the upper portion thus also may have a regular design.

[0018] This has as an advantage that, on one hand, the stones still can be laid against each other, whereas, on the other hand, a joint which can be filled with sand or another filling agent can be created at the visible upper surface. Another advantage consists in that it becomes possible to still create joints between stones which are laid adjacent to each other, at least at the upper surface, which joints can be filled with a hardening mortar, for example, on the basis of cement, as a result of which an entirely tight surface of the pavement can be realized. This is particularly useful when constructing a terrace, as thereby the emergence of sand from in between the stones, which often is the case when concrete stones are laid loosely next to each other, is entirely prevented. Also, this is useful in applications where the seeping-in of water must be limited or be avoided and/or where it is desired that the risk of weeds growing between the stones is minimized.

[0019] It is clear that also in this case, the receding portion preferably is realized such that, when laying this stone together with similar stones, so to speak, reversed wedge-shaped joint openings are created.

[0020] It is noted that the application of portions enhancing the passage of water between the respective stones, which portions only start at a lower level, such that they always are hidden from view in respect to the pavement, also can be advantageous in combination with embodiments of stones of which the upper portion not necessarily, as aforementioned, has an irregular or particular shape.

[0021] According to a third aspect of the invention, it thus relates to a stone for forming a pavement, with as a characteristic that it comprises an upper portion with such a contour that around this upper portion, in respect to a contour formed by the portion situated therebeneath, a receding portion is formed, and that this stone is provided at its side with portions which, when several of such stones are laid next to each other, form a passage for water, which portions, seen from the top downward, start below said upper portion in order to extend up to the bottom of the stone.

[0022] In general, it is preferred that said irregularly shaped portion and/or said receding portion extends over a height, depth, respectively, of at least 0.5 cm and still better at least 1 cm, such that a joint filling can be safely guaranteed, even if it consists of loose sand.

[0023] From the preceding, it is clear that the invention is particularly useful in the case of concrete stones.

[0024] With the intention of better showing the characteristics of the invention, hereafter, as an example without any limitative character, several preferred forms of embodiment are described, with reference to the accompanying drawings, wherein:

[0025] FIG. 1 in perspective represents a stone according to the invention;

[0026] FIGS. 2 and 3 represent the stone from FIG. 1 in side view, top view, respectively;

[0027] FIG. 4 represents a portion of the pavement, formed of stones, such as represented in FIGS. 1 to 3;

[0028] FIG. 5 represents a cross-section according to line V-V in FIG. 4;

[0029] FIGS. 6 to 8 represent views analogous to those of FIGS. 1 to 3, for a variant;

[0030] FIGS. 9 to 11 represent still another variant;

[0031] FIGS. 12-13 and 14-15 represent another two variants;

[0032] FIG. 16 represents a particular form of embodiment.

[0033] As represented in FIGS. 1 to 5, the invention relates to a stone 1 for forming a pavement 2, which, on one hand, comprises an irregularly or particularly shaped upper portion 3 and, on the other hand, is provided with means 4 which allow to lay such stone 1, together with other similar stones 1, in a regular manner.

[0034] The means 4 consist of contact parts 5 which are situated at the sides 6 of the stone 1, lower than the upper side 7 of the stone 1, whereby these contact parts 5 determine a regular contour 8, which in FIG. 3 is indicated in dashed line. These contact parts 5 consist of the side walls of a regularly shaped lower portion 9 which is situated beneath said upper portion 3 and which is realized in the shape of a base.

[0035] Seen in top view, the contour of the upper portion 3 is situated within said contour 8, as becomes clear from FIG. 3.

[0036] In this manner, the upper portion 3 has a portion 10 receding in respect to the lower portion 9.

[0037] As becomes clear from FIGS. 1 and 2, as well as FIG. 5, the receding portion 10 preferably is realized as an undercut, which is formed by a side 11 narrowing downward, such that when laying such stone 1 together with similar stones 1, so to speak, a wedge-shaped joint opening 12 is created, as can be seen in FIG. 5.

[0038] Further, the stone 1, at its side, more particularly at one or more sides, preferably is provided with portions 13 which, when several of such stones 1 are laid laterally against each other, guarantee a passage 14 for water, such as indicated in FIG. 5, which portions 13 start in downward direction beneath the irregularly shaped upper portion 3 and/or from the underside 15 of the receding portion 10.

[0039] In this case, the portions 13 are formed by vertical grooves which are provided in the respective lateral faces 6.

[0040] The height H over which the upper portion 3 and/or the receding portion 10 extend, which also can be denominated as the depth of the joint opening 12, preferably is at least 0.5 cm and still better at least 1 cm.

[0041] The application of the stones 1, more particularly, the manner in which a pavement 2 can be formed therewith, can simply be deduced from the above description, as well as from FIGS. 4 and 5; however, for clarity's sake, it will be explained hereafter in short.

[0042] As represented in FIG. 5, the stones 1 are provided on a, for example, flat sand bed 16, as this traditionally also is performed with classical clinkers. Hereby, they are simply positioned with their contact portions 5 against each other.

[0043] In that the upper portions 3 always are situated within the contour 8 of the lower portion 9, the irregular

design of the upper portions **3** does not form an obstacle for laying the stones **1** in a regular manner.

[0044] Hereby, relatively deep joint openings **12** are created, which, as aforementioned, preferably have a reversed wedge shape, or, defined more exactly, show a dovetail shape. As a result of the relatively deep joint openings **12**, it is obtained that, after they have been filled up with sand **17** or such, this sand **17** hardly can leave the joint openings **12**, such that the lower portion **9** in a guaranteed manner remains hidden from view. Due to the wedge shape, the sand **17** moreover is retained better in the joint openings **12**.

[0045] As the aforementioned portions **13** also start at a relatively large distance, to wit a distance which coincides with the height **H**, under the upper side **7** of the stone **1**, also always sand **17** or such will be present thereabove, as a result of which it is obtained that it is impossible for the portions **13** to disturb the appearance at the upper surface, when the joint openings **12** are filled in a normal manner.

[0046] It is clear that the invention is not restricted to a certain stone design. As examples, in FIGS. **6** to **16** a number of variants of such a stone **1** is represented.

[0047] FIGS. **6** to **8** hereby show a stone **1** which is bent and wedge-shaped.

[0048] FIGS. **9** to **11** show a variant whereby the lower portion **9** has a relatively small height and whereby the receding portion **10** is realized as a hollow part extending around the circumference.

[0049] FIGS. **12** and **13** represent a variant whereby the irregularly shaped upper portion **3** at the top has a straight side, however, somewhat more downward has an inclined side **11** which then forms an actual undercut.

[0050] In FIGS. **14** and **15**, another variant is represented, whereby the upper portion **3** at its base connects to the lower portion **9**, this contrary to the embodiments from FIGS. **1** to **13**, whereby the transition between the upper portion **3** and the lower portion **9** is step-shaped.

[0051] FIG. **16** shows that the contact parts **5** not necessarily have to consist of a massive base, but may also be realized as locally present elements, in this case, at the lower corners of the stone **1**.

[0052] Finally, it is noted again that the use of a receding portion **10** and/or the use of portions **13** starting only at a lower level, also is possible in combination with stones **1**, the upper portion of which does not show an irregular design, but, for example, is made regularly, either with straight sides, or with sides showing a regularly shaped profile.

[0053] The present invention is in no way limited to the forms of embodiment described as an example and represented in the figures; on the contrary may such stone be realized in different forms and dimensions, without leaving the scope of the invention.

1.- Stone for forming a pavement, characterized in that it comprises an upper portion (**3**) with such a contour that along the side of the upper portion (**3**), in respect to a contour (**8**) formed by a portion situated therebeneath, a receding portion (**10**) is formed, such that, when laying this stone (**1**) against similar stones (**1**), next to the upper portions (**3**) of these stones (**1**), a joint opening (**12**) is created which is suitable for being filled with a filling agent, whereby said receding portion shows an undercut.

2.- Stone according to claim 1, characterized in that the receding portion (**10**) is realized such that, when laying this stone (**1**) together with similar stones (**1**), so to speak reversed wedge-shaped and/or dovetail-shaped joint openings (**12**) are created.

3.- Stone according to claim 1 or 2, characterized in that it has, on one hand, an irregularly or particularly shaped upper portion (**3**) and, on the other hand, is provided with means (**4**) which allow to lay such stone (**1**), together with other, similar stones (**1**), in a regular manner.

4.- Stone according to claim 3, characterized in that said means (**4**) consist of contact portions (**5**) located at the side of the stone (**1**), lower than the upper side of the stone (**1**), which portions determine a regular contour (**8**).

5.- Stone according to claim 4, characterized in that, seen in top view, the contour of said upper, irregularly shaped portion (**3**) is situated within said regular contour (**8**).

6.- Stone according to any of the claims 3 to 5, characterized in that said means (**4**) consist of a regularly shaped portion (**9**) which is situated beneath said irregularly shaped upper portion (**3**) and, more particularly, is realized in the form of a base.

7.- Stone according to any of claims 1 to 6, characterized in that, at the side thereof, it is provided with portions (**13**) which, when several of such stones (**1**) are laid laterally against each other, guarantee a passage (**14**) for water, which parts (**13**), seen from the top towards the bottom, start below the irregularly shaped portion (**3**) and/or from the lower edge (**15**) of the receding portion (**10**).

8.- Stone according to claims 6 and 7, characterized in that the portions (**13**) forming a passage (**14**) for the water, consist of one or more grooves which are formed in one or more sides (**6**) of said base.

9.- Stone according to any of the preceding claims, characterized in that this stone (**1**), at its side, is provided with portions (**13**), which, when several of such stones (**1**) are laid adjacent to each other, form a passage (**14**) for water, which portions (**13**), seen from the top towards the bottom, start below said upper portion (**3**) in order to extend up to the bottom of the stone (**1**).

10.- Stone according to any of the preceding claims, characterized in that said irregularly shaped portion (**3**) and/or said receding portion (**10**) extend over an height (**H**) or, thus, depth of the joint opening (**12**) which is at least 0.5 cm and still better at least 1 cm.

11.- Stone according to any of the preceding claims, characterized in that it is a concrete stone (**1**).

\* \* \* \* \*