



INTERNATIONAL APPLICATION PUBLISHED UNDER THE PATENT COOPERATION TREATY (PCT)

<p>(51) International Patent Classification ⁵ : C12M 1/40, C12Q 1/54, A61B 5/00, G01N 27/327</p>	<p>A1</p>	<p>(11) International Publication Number: WO 94/20602 (43) International Publication Date: 15 September 1994 (15.09.94)</p>
<p>(21) International Application Number: PCT/CA94/00107 (22) International Filing Date: 28 February 1994 (28.02.94) (30) Priority Data: 9304306.5 3 March 1993 (03.03.93) GB (71) Applicant (for all designated States except US): THE GOVERNORS OF THE UNIVERSITY OF ALBERTA [CA/CA]; Intellectual Property and Contracts Office, 1-3 University Hall, Edmonton, Alberta T6G 2J9 (CA). (72) Inventors; and (75) Inventors/Applicants (for US only): MOUSSY, Francis, Gabriel [CA/CA]; 11420 60 Avenue, Edmonton, Alberta T6H 1J5 (CA). HARRISON, Daniel, Jed [CA/CA]; 8932 - 151 Street, Edmonton, Alberta T5R 1J2 (CA). RAJOTTE, Raymond, Victor [FR/CA]; 933 Blackett Wynd, Edmonton, Alberta T6W 1A9 (CA). (74) Agent: RAE, Patricia, A.; Sim & McBurney, Suite 701, 330 University Avenue, Toronto, Ontario M5G 1R7 (CA).</p>		<p>(81) Designated States: AT, AU, BB, BG, BR, BY, CA, CH, CN, CZ, DE, DK, ES, FI, GB, HU, JP, KP, KR, KZ, LK, LU, LV, MG, MN, MW, NL, NO, NZ, PL, PT, RO, RU, SD, SE, SK, UA, US, UZ, VN, European patent (AT, BE, CH, DE, DK, ES, FR, GB, GR, IE, IT, LU, MC, NL, PT, SE), OAPI patent (BF, BJ, CF, CG, CI, CM, GA, GN, ML, MR, NE, SN, TD, TG). Published <i>With international search report.</i></p>

(54) Title: IMPLANTABLE GLUCOSE SENSOR

(57) Abstract

An implantable sensor for sensing and measuring a component of a biological fluid, for example glucose, wherein the working electrode of the sensor has an inner coating of low permeability polymer, an enzyme-immobilised layer over the inner coating and an outer coating of a perfluorinated ionomer polymer over the enzyme-immobilised layer.

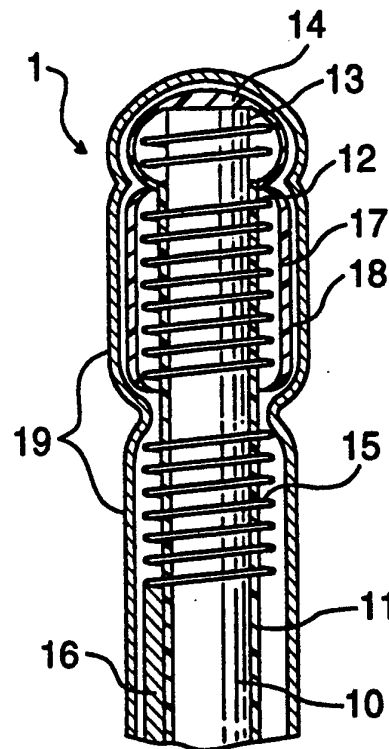

FOR THE PURPOSES OF INFORMATION ONLY

Codes used to identify States party to the PCT on the front pages of pamphlets publishing international applications under the PCT.

AT	Austria	GB	United Kingdom	MR	Mauritania
AU	Australia	GE	Georgia	MW	Malawi
BB	Barbados	GN	Guinea	NE	Niger
BE	Belgium	GR	Greece	NL	Netherlands
BF	Burkina Faso	HU	Hungary	NO	Norway
BG	Bulgaria	IE	Ireland	NZ	New Zealand
BJ	Benin	IT	Italy	PL	Poland
BR	Brazil	JP	Japan	PT	Portugal
BY	Belarus	KE	Kenya	RO	Romania
CA	Canada	KG	Kyrgyzstan	RU	Russian Federation
CF	Central African Republic	KP	Democratic People's Republic of Korea	SD	Sudan
CG	Congo	KR	Republic of Korea	SE	Sweden
CH	Switzerland	KZ	Kazakhstan	SI	Slovenia
CI	Côte d'Ivoire	LI	Liechtenstein	SK	Slovakia
CM	Cameroon	LN	Sri Lanka	SN	Senegal
CN	China	LU	Luxembourg	TD	Chad
CS	Czechoslovakia	LV	Latvia	TG	Togo
CZ	Czech Republic	MC	Monaco	TJ	Tajikistan
DE	Germany	MD	Republic of Moldova	TT	Trinidad and Tobago
DK	Denmark	MG	Madagascar	UA	Ukraine
ES	Spain	ML	Mali	US	United States of America
FI	Finland	MN	Mongolia	UZ	Uzbekistan
FR	France			VN	Viet Nam
GA	Gabon				

IMPLANTABLE GLUCOSE SENSOR

This invention relates to electrochemical sensors. More particularly, it relates to miniaturised sensors
5 suitable for implantation.

Background of the Invention

Enzyme-based electrochemical sensors have been explored for detection of many biological compounds such
10 as oxalate, salicylate, urate, urea, cholesterol, choline, acetylcholine, creatinine, lactate and glucose.

One much-studied example is a glucose sensor, based on the enzyme, glucose oxidase. In one form of glucose
15 sensor, the hydrogen peroxide generated by glucose oxidase action on glucose is oxidised at about 0.7 V versus a reference electrode to produce an electric current.

The potential use of a glucose sensor for the treatment of diabetes includes continuous glucose
20 monitoring, the development of an alarm device for detecting hypoglycaemia and, ultimately, part of a closed-loop insulin delivery system. For these reasons there has been a continued effort to develop an implantable glucose sensor. Due to the potential hazards
25 of intravascular glucose sensing, most studies have focused on the development of needle-type glucose sensors for subcutaneous glucose monitoring, as the glucose concentration in subcutaneous tissue has been shown to follow closely plasma glucose
30 concentrations (Fisher et al., (1987), Diabetologia, vol. 30, pp. 940-945).

Several needle-type, enzymatic glucose sensors have been developed, but poor biostability or biocompatibility has limited their effectiveness when implanted (Schichiri
35 et al., (1986), Diabetes Care, vol. 9, pp. 298-301; Schichiri et al., (1983), Diabetologia, vol. 24, pp. 179-184).

Bindra et al., (Anal. Chem., (1991), vol. 63, pp. 1692-1696) and Moatti-Sirat et al., (Diabetologia, (1992), vol. 35, pp. 224-230) have reported results for a needle-type sensor coated with polyurethane, which worked for at least 10 days after implantation in animals. This sensor was well protected against interferences, but exhibited low sensitivity and required about 4 hours to stabilize after implantation and subsequent polarization.

Harrison et al. (Anal Chem., (1988), vol. 60, pp. 2002-2007) have reported the in vitro use of a perfluorinated ionomer polymer as an outer layer for glucose oxidase-based electrodes. This sensor had poor selectivity and was sensitive to movement and liquid flow rate.

Previously available glucose sensors had very low sensitivity or did not function in vivo for more than two or three days.

Summary of the Invention

In accordance with one aspect of the invention, an implantable sensor is provided for sensing and measuring at least one selected component of a biological fluid or tissue comprising a reference electrode and a working electrode,

the working electrode comprising conducting means, an inner coating comprising a low permeability polymer film applied to the conducting means, an enzyme-immobilised layer applied over the inner coating and containing an enzyme specific for the selected component, the catalytic activity of the enzyme being indicative of the selected component, and an outer coating of a perfluorinated ionomer polymer applied over the enzyme-immobilised layer, the conducting means being capable of oxidising or reducing a product of the catalytic activity of the enzyme,

and the reference electrode having an outer coating of a perfluorinated ionomer polymer.

In accordance with a further aspect of the invention, an improved sensor is provided for sensing and measuring at least one selected component of a biological fluid or tissue having a reference electrode and a working electrode, the improvement comprising an inner coating of poly(o-phenylene diamine) applied to the working electrode, an enzyme-immobilised layer applied over the inner coating and containing an enzyme specific for the selected component, the catalytic activity of the enzyme being indicative of the selected component and an outer coating of a perfluorinated ionomer polymer applied over the enzyme-immobilised layer and the reference electrode having an outer coating of the perfluorinated ionomer polymer.

In accordance with a further aspect of the invention, a method is provided for preparing an implantable sensor for sensing and measuring at least one selected component of a biological fluid or tissue comprising the steps of

- (a) providing a working electrode and a reference electrode;
- (b) coating the working electrode with an inner coating comprising a low permeability polymer film;
- (c) applying over the inner coating an enzyme-immobilised layer containing an enzyme specific for the selected component, the catalytic activity of the enzyme being indicative of the selected component; and
- (d) applying an outer coating of a perfluorinated ionomer polymer over the enzyme-immobilised layer of the working electrode and over the reference electrode.

Description of the Drawings

Certain embodiments of the invention are described, reference being made to the accompanying drawings, wherein:

Figure 1 shows a schematic diagram of one embodiment of the sensor of the invention.

Figure 2 shows the response of the sensor of Figure 1 to addition of ascorbate, uric acid and acetaminophen in the indicated concentrations along with 5.6 mM glucose to a pH 7.4 buffer.

Figure 3 shows the response of a Pt/GOx/Nafion electrode (upper trace) and a Pt/15minPPD/GOx/Nafion electrode (lower trace) in 20 mM glucose in pH 7.4 buffer, as solution stirring is stopped and then recommenced at indicated times.

Figure 4 shows a Levich plot of current versus square root of rotation rate in revolutions per minute (RPM) of naked and PPD coated Pt rotating disk electrodes in 20 mM H₂O₂, pH 7.4. PPD was deposited by electrolysis for 0 (○), 2 (●), 5 (□) or 15 (■) min.

Figure 5 shows response of an electrode with 5 min PPD deposition, when glucose was added at the indicated concentrations to phosphate buffer, pH 7.4, (●) or fresh heparinised dog blood (○).

Figure 6 shows blood glucose level in mg/dl (○) and sensor current (●) in an active healthy dog after rapid bolus injection of glucose intravenously, monitored by a Pt/5 min PPD/GOx/Nafion sensor.

Figures 7A and 7B show blood glucose level in mg/dl (●) and sensor current (□) in an active healthy dog after a rapid intravenous injection of glucose monitored by a Pt/5minPPD/GOx/Nafion sensor. Figure 7A results were obtained immediately after sensor implantation and Figure 7B results 7 days after sensor implantation.

Figures 8A to 8D show blood glucose level in mg/dl (□) and sensor current (□) at days 1 (Fig. 8A), 3 (Fig. 8B), 7 (Fig. 8C) and 10 (Fig. 8D) during long-term monitoring by a Pt/5minPPD/GOx/heat-cured Nafion sensor.

Detailed Description of the Invention

The present invention provides an improved enzyme-based implantable sensor, showing a more rapid response than previously available sensors, along with a shorter stabilisation period.

In accordance with one embodiment, the sensor of the invention may be utilised to measure glucose, by incorporation of glucose oxidase as the immobilised enzyme. Many selected components other than glucose may, however, be measured by means of an enzyme-based sensor in accordance with the invention, by incorporation of an appropriate immobilised enzyme.

The sensor of the invention has a three-layer coating over the working electrode. The working electrode may be any conducting material which is able to oxidise or reduce a selected product of enzyme action on the selected component to be measured. For a glucose sensor, platinum (Pt) is preferred.

In accordance with a preferred embodiment, the inner coating, which is applied to the Pt electrode, comprises a film of poly(o-phenylene diamine) (PPD) which reduces interference by small electroactive compounds.

The middle layer comprises an immobilised enzyme specific for the component to be measured, such that the products of catalytic action of the enzyme on the selected component can be detected and are indicative of the presence and amount of the selected component.

In accordance with preferred embodiment of the invention, the middle layer comprises glucose oxidase (GO_x) immobilised in a matrix of bovine serum albumin (BSA).

The third or outer coating over the working electrode is a film of a perfluorinated ionomer polymer such as perfluorosulphonic acid polymer or Nafion (Dupont) or perfluorocarboxylic acid polymer. The reference electrode is also coated with a film of perfluorinated ionomer polymer. The polymer film over

both electrodes provides a biocompatible, protective outer coating. An outer coating of Nafion is especially preferred. Nafion can exist in acidic or basic form; the acidic form is preferred.

5 The reference electrode should be of a material which gives a stable potential in a chloride ion-containing medium. A silver/silver chloride (Ag/AgCl) reference electrode is preferred.

10 Figure 1 illustrates in diagrammatic form a preferred design for the sensor of the invention. Reference and working electrodes are located close to each other on a support, the PPD and immobilised enzyme layers are applied to the working electrode and the sensor is coated with an outer Nafion layer, as more
15 fully described in Example 1.

 The inventors have found that a sensor having the above-described three-layer coating on its working electrode shows better selectivity and improved performance in vivo and in blood in vitro. Glucose
20 sensors in accordance with the invention showed good selectivity, a sensitivity range of about 3 to about 25 nA/mM glucose and a 90% response time in vitro of 33 seconds. They also required a shorter stabilisation period following polarisation than previously described
25 sensors, requiring only about 10 to about 30 minutes in vitro and about 30 to about 50 minutes in vivo.

 In in vivo studies in active dogs, the sensor current closely followed the plasma glucose level during a glucose tolerance test, as seen in Figure 6. The 3
30 minute delay observed corresponds to the known lag time for subcutaneous glucose levels. The ability to reduce mass transport rate dependence on the signal without a major change in sensitivity is another aspect of the improved performance obtained with the sensor of the
35 invention.

 The innermost coating comprises a low permeability polymer film, preferably applied by electrodeposition.

Sensors have been prepared using a film of polymerised phenol/allyl phenol instead of PPD for the innermost layer. Such sensors show similar selectivity but the film morphology is rougher, indicating a less homogenous
5 film.

An inner coating of PPD is preferred. In accordance with a preferred embodiment, PPD is electrodeposited on the working electrode of the sensor for a period in the range of 30 seconds to about 20 minutes. The longer PPD
10 is electrodeposited, the more selective is the sensor but sensitivity tends to decrease as PPD thickness increases. As will be understood by those skilled in the art, an optimum is selected which gives the desired selectivity while maintaining adequate sensitivity. PPD deposition
15 for about 5 minutes from a solution of 5 mM is especially preferred for the glucose sensor.

The Nafion outermost coating is preferably built up in several layers by several dip coatings. A sequence of 1 coating of 0.5% w/v Nafion, 1 coating of 3% Nafion and
20 4 consecutive coatings of 5% Nafion, giving a total Nafion thickness of about 10 μ m, is especially preferred.

Each dip coat of Nafion is allowed to dry for 30 minutes before application of the next layer.

The entire sensor assembly of Figure 1, including Pt
25 working electrode and Ag/AgCl reference electrode, was fashioned to be no more than 0.5 mm in diameter and was therefore insertable subcutaneously into the tissues to be monitored through an 18 gauge needle.

In accordance with a further embodiment of the
30 invention, the inventors have found that heat curing of the Nafion layer after fabrication of the sensor is very beneficial for the long-term stability of the sensor of the invention. Surprisingly, it has been found that the Nafion layer can be cured at up to 120°C without damage
35 to the enzyme layer on which the sensor depends for its response.

As seen in Figure 7, which shows in vivo monitoring with a Pt/5minPPD/GOx/Nafion sensor over a period of 7 days, over this period of time the sensor shows a tendency to lose sensitivity. Although sensitivity is well maintained for short term uses, such as monitoring surgery, this loss of sensitivity over the longer term is undesirable.

Examination of the sensor after 7 days of implantation showed cracking of the Nafion outer coating and deterioration of the reference electrode.

It has been found by the inventors that heat curing of the sensor greatly improves the resistance of the Nafion layer to cracking and biological degradation and surprisingly does not destroy the activity of the enzyme layer. The sensor is heat cured after fabrication, when all the described coating layers have been applied. The fabricated sensor is preferably heated in an air oven at a temperature in the range of about 110°C to about 150°C for a period of about 30 minutes to about 5 hours. This process also provides a convenient means of sterilising the sensor.

Heat curing of the sensor at about 120°C for about 60 minutes is especially preferred.

The results of a long-term study using a heat cured glucose sensor in accordance with the invention are shown in Figure 8.

The sensor was cured at 120°C for 60 minutes before use. As seen in Figure 8, the sensor remained functional over the 10 days of the study, without a significant change of sensitivity or loss of performance.

Due to a somewhat lower permeability of the Nafion layer to glucose after curing, the sensitivity of the sensor was reduced about sevenfold by curing and the necessary stabilisation period was increased by about 10 minutes. Sensitivity remained, however, sufficient to detect small variations of glucose concentration during

in vivo blood glucose monitoring and response time was unaffected.

As will be understood by those skilled in the art, a sensor in accordance with the invention may be fashioned for measurement of a variety of selected components of biological fluids, by selection of a suitable enzyme. For example, acetyl choline, choline, creatinine, urea, cholesterol, ethanol or glycerol sensors may be prepared using immobilised acetylcholine esterase, choline oxidase, creatinine amidohydrolase, urease, cholesterol oxidase, alcohol dehydrogenase or glycerol oxidase respectively.

As will be understood by those skilled in the art, the thickness of the PPD layer and of the outer Nafion layer may need to be adjusted to optimise selectivity for measurement of a particular selected component.

EXAMPLES

The following examples illustrate the construction and performance of glucose sensors in accordance with the invention, as shown in Figures 1 to 8. It will be understood, however, that the examples are illustrative only and do not limit the scope of the invention.

25

Example 1

Materials. High-purity glucose oxidase (Aspergillus Niger, Calbiochem, La Jolla, CA, USA or Sigma Chemicals, U.S.A.), bovine serum albumin (Fraction V, 98099% albumin, Sigma), and glutaraldehyde (25% aqueous solution, Sigma) were used as received. All other chemicals were reagent grade. Solutions were prepared from doubly distilled, deionized water.

A pH 7.4 phosphate buffer solution (PBS) was prepared from phosphate salts with sodium benzoate (5 mM) and ethylenediaminetetraacetic acid (1 mM) as preservatives and NaCl (0.1 M) as electrolyte. Glucose

(0.1 M) was added and allowed to mutarotate overnight at room temperature, then stored at 4°C. Solutions of interfering species in pH 7.4 buffer were prepared just before use, as was 5 mM o-phenylenediamine (o-PD)

5 (Aldrich) in an acetate buffer (pH 5.5).

Nafion solutions (Solution Technology Inc., Mendenhall, PA, USA) of 0.5 and 3% wt/vol were prepared by dilution with 1:1 2-propanol and water.

Equipment. Amperometry was performed using a Pine RDE-4
10 potentiostat (Pine Instrument Company, Grove City, PA, USA). A Pine MSR rotator and Pt rotating disk electrode (0.5 cm diam.) were also used. During in vitro experiments, a three-neck, glass, round-bottom flask served as the electrochemical cell. Stirring was
15 provided with an air-driver magnetic stirrer. Data were recorded using either an x-y-t BD 91 recorder (Kipp & Zonen, Delft, Holland) or an Omniscribe strip chart recorder (Houston Instruments, Austin, TX, USA).

A 10 cm long (0.2 mm diam.) varnished copper wire 10
20 insulated by a coating of varnish 11 was used as the supporting element of the needle-type sensor 1, as shown diagrammatically in Figure 1. A platinum wire working electrode 12 (0.1 mm diameter) was coiled ten times around the insulated copper wire 10. The varnish was
25 removed from the copper wire over a length of about 1 mm at one end 13 and electrical contact was made between the copper wire and platinum electrode by winding the platinum wire a couple of times around the unvarnished end 13 of the copper wire. The contact area was
30 reinsulated by painting a coating of varnish 14 over it (Red GLPT insulating varnish, Cardinal, Edmonton). One mm away from the coiled platinum wire, a silver wire reference electrode 15 (0.1 mm diam.; Puratronic, Johnson Matthey) was coiled 15 times around the insulated copper
35 wire 10. This silver wire was connected to another varnished copper wire 16 (0.15 mm diam.). Silver chloride was formed on the reference electrode 15 by

anodizing at 0.4 versus SCE (initially 0.4 mA/cm²) for 30 min through the coiled silver wire in stirred 0.1 M HCl, and then rinsing with deionized water.

5 The coiled platinum wire 12 was prepared to receive the three-layer coating by anodizing at 1.9 V and cycling between -0.26 and + 1.1 V vs a saturated calomel electrode (SCE) in 0.5 M H₂SO₄.

10 The innermost coating 17 over the working electrode was applied by growing a film of PPD electrochemically on the platinum electrode 12 from a fresh, de-aerated, unstirred o-phenylenediamine solution (5 mM) at a potential of +0.65V vs SCE, as described by Malitesta et al. (Anal. Chem., (1990), vol. 62, pp. 2735-2740).

15 The sensor was rinsed and the immobilised glucose oxidase layer 18 was formed over the PPD layer by carefully passing the working electrode through the drop formed in a V-shaped wire by dipping it into a solution of 19.5 mg/ml glucose oxidase, 73.2 mg/ml BSA and 5 mg/ml glutaraldehyde in acetate buffer, pH 5.5. About 1 µl of enzyme solution was deposited on the working electrode.

20 The sensor was then dried for 30 minutes in air at room temperature. The entire sensor (reference and working electrodes) was then dip coated with several layers of Nafion, by dipping once in 0.5% Nafion, once in 25 3% Nafion and four times in 5% Nafion, to give a Nafion coating 19 of about 6-10 µm total thickness over the entire sensor.

The sensor was stored dry at room temperature or in 0.05 M phosphate buffered saline (PBS) at 4°C.

30 As will be understood by those skilled in the art, metal wires of smaller or larger diameter may be used for the electrodes and the number of coils may be increased or decreased. When the net surface area is increased, the sensitivity will be higher, while if the net surface area is decreased, the sensitivity will decrease. A glucose sensor of final diameter in the range of about 35 0.05 mm to about 1 mm is preferred.

Example 2

The effectiveness of the innermost PPD coating in protecting the sensor from interfering substances and improving selectivity was examined by comparing sensors with and without a PPD layer, or with different thicknesses of PPD.

The effect of several common interfering species present in biological samples was evaluated in phosphate buffer solution. Needle-type sensors were prepared as described in Example 1, with PPD electrodeposition for 5 to 15 minutes (Pt/5minPPD/GOx/Nafion and Pt/15minPPD/GOx/Nafion respectively) or with no PPD layer (Pt/GOx/Nafion).

Figure 2 illustrates the difference in response to the addition of ascorbate, uric acid and acetaminophen at a Pt/GOx/Nafion and a Pt/15 min PPD/GOx/Nafion electrode in a 5.6 mM glucose solution. The decrease in interference by several species with PPD present is apparent, while it is clear that the commonly used drug, acetaminophen still permeates the membranes.

A more quantitative measure of the effectiveness of the PPD film was obtained by measuring the change in the sensor response when compounds were introduced at their maximum physiological concentration. In Table I the percentage increase in sensor current when the interferent was added to a 5.6 mM glucose solution is expressed as the apparent error. This is the maximum error that should be observed in blood for the compounds studied. When a Nafion coating alone was used interferences occurred. Electrodeposition of PPD for 15 min prior to coating with GOx and Nafion gave complete protection against uric and ascorbic acids and urea. Sensors coated with PPD by a 5 min oxidation were less blocking to the interferents, but were still substantially protected. However, PPD was permeated by acetaminophen. In addition, L-cysteine poisoned the sensors, producing a continuous, slow decline in sensor

output. This effect could be reversed by rinsing and testing in fresh solution. Despite this, it is clear that the PPD film significantly enhances sensor selectivity.

5

Example 3

Hydrodynamic Flow Dependence. The effect of flow rate on sensor response is a critical factor, and it is desirable
10 to obtain mass transport rate independence. Sensors coated with GOx and Nafion show the expected decrease in current with decreasing mass transport rates. However, sensors with PPD, prepared by 15 min electrolysis, and present as an underlayer to GOx and Nafion, showed an
15 increase in current as mass transport rates decreased. Figure 3 shows this for a needle-type sensor in a stirred solution.

The dependence of the needle-type sensor current on mass transport rate in a 20 mM glucose solution was
20 evaluated by turning a magnetic stirrer on and off for sensors with PPD undercoatings prepared by 5 and 15 min of electrolysis. Table II shows the change in current caused when stirring was stopped, expressed as the percentage change of the current relative to a stirred
25 solution. Tables I and II show that a 5 min PPD film gives an excellent compromise between protection from interferences and stir rate independence. This will of course be more significant for a sensor implanted intravenously, since there will be minimal flow in
30 subcutaneous sites.

The unusual mass transport rate dependence of PPD coated electrodes was examined using the controlled hydrodynamics of the rotating disk electrode (RDE). A Pt RDE was coated with PPD alone by electrodeposition for 2,
35 5, and 15 min. Figure 4 shows a Levich plot of the anodic current at 0.7 V vs SCE for a 20 mM H₂O₂ solution as a function of (rotation rate)^{1/2} for a naked electrode

and the different coating thicknesses. The data shows that the film's permeability decreased with increasing film thickness. Further, the weak rotation rate dependence for even the shortest film deposition period shows PPD is poorly permeable to H_2O_2 , despite the rapid (< 1 s) response times noted by Malitesta (1990, above).

The low permeability of the PPD film is beneficial in terms of selectivity against larger molecules and ions, but also leads to the unusual mass transport dependence. At the glucose electrode, H_2O_2 is generated within the GOx layer and is free to diffuse in all directions. With the PPD layer present, increasing the mass transport rate sweeps H_2O_2 out into solution before it can diffuse through the PPD barrier to the electrode. Thus, even though the rate of glucose reaction and H_2O_2 generation will increase, the H_2O_2 current will decrease. This effect can be used to advantage to eliminate flow rate dependence, by balancing the flux of H_2O_2 through the PPD film against the flux of H_2O_2 through the Nafion film to the external solution.

In vitro sensor evaluation. The needle-type sensor was characterized in pH 7.4 phosphate buffer or heparinized canine blood at 0.7 V vs the incorporated Ag/AgCl reference electrode (19.2 ± 0.2 mV vs SCE in PBS). The steady state current was measured as a function of added glucose concentration. An air driven magnetic stirrer was used, for which it was possible to obtain the same response from a given sensor by careful adjustment of the stir rate and sensor positioning.

One function of the outer Nafion membrane is to reduce the flux of glucose to the platinum electrode surface in order to extend the linear dynamic range to 20 mM. Table III gives the average sensitivities and background currents for 19 needle-type sensors, configured with a 5 min PPD/GOx/Nafion multilayer, that had an upper linear range of at least 20 mM glucose in

phosphate buffer solution. The significant standard deviations shown in Table III for these hand made sensors are due to variations in Pt electrode area and the thickness of each of the three coatings. The response time of these sensors was shorter (33 ± 13 s) than that observed for polyurethane coated sensors and slightly longer than the 24 s observed for Pt/GOx/Nafion sensors. (A 24 s response time indicates a Nafion thickness in the range of 6 to 10 μm). The polarization period required before a stable basal signal was obtained was between 10 to 30 minutes. This is considerably shorter than the 2 hours reported by Bindra et al (1991, above), and may be important during clinical applications when the sensor output is monitored only periodically.

A Pt/5minPPD/GOx/Nafion sensor was tested in canine blood in vitro. Figure 5 compares the current for the same sensor as glucose was added to either phosphate buffer or blood. Linear response was observed in both solutions, and the currents were stable over time. The non-zero intercept in whole blood was due to the endogenous glucose level. There was a decrease in electrode sensitivity in blood, which is likely due to the adsorption of blood proteins on the Nafion reducing the permeability of the outer membrane. This effect was reversed by washing the sensors in buffer. The decreased sensitivity in blood indicates that the sensor should be calibrated in vivo to assure its accuracy, but this is also required for other needle-type sensors when implanted.

30

Example 5

Needle-type sensors with a Pt/5minPPD/GOx/Nafion working electrode (prepared as in Example 1) were evaluated during acute experiments in healthy non-anaesthetised female dogs.

35

An indwelling 20 gauge catheter was placed in a foreleg vein for glucose infusion and blood sampling. A

sensor first tested in vitro was inserted through a skin fold of the neck using an 18 gauge catheter. The catheter was removed leaving the sensor under the skin and the sensor was then biased at +0.7 V. After the
5 sensor signal stabilized a blood sample was taken. A bolus of glucose (0.5 g/kg body weight) was then injected through an indwelling venous catheter and blood was taken at 1, 5, 10, 15, 30, 60 and 90 minutes after glucose administration.

10 About 30 to 40 min was required for stabilization of the current following implantation and polarization, and an intravenous glucose tolerance test was then performed. The changes in plasma glucose and sensor output are shown in Figure 6. The sensor signal matched the glycemia of
15 the dog very well. The delay of 3 minutes for the peak is consistent with the lag time between subcutaneous and blood glucose levels.

Example 6

20 For longer term implantations, needle-type sensors were placed in modified catheters to reduce the risk of accidental removal and transcutaneous infection. A chronic venous catheter allowed collection of blood over several days.

25 Silastic catheters, 0.062 in i.d. x 0.125 in o.d., were used for chronic implantation of the glucose sensor (4 cm long) and the venous catheter (70 cm long), and prepared as described by O'Brien et al. (J. Pharmacol. Methods (1991), vol. 25, pp. 157-170). Briefly, a 2 cm
30 diameter, double velour, dacron flange (Meadox, Oakland, NJ) was placed around each catheter near the external end, and held in place with medical grade silastic adhesive (Dow Coming, Midland, MI). A glucose sensor with a Pt/5minPPD/GOx/Nafion working electrode (prepared
35 as in Example 1) was first tested in vitro, then inserted into the 4 cm catheter and secured in place by injecting silicone adhesive. The sensitive tip of the sensor

extended 4 mm from the catheter's end. The sensor and venous catheters were then sterilized with UV irradiation and ethylene oxide, respectively. Under halothane anaesthesia, the sensor was inserted up to the dacron
5 flange through a small incision made in the neck, which was then sealed. The venous catheter was inserted in the right, external jugular. The use of dacron flanges promotes tissue growth and prevents infection and removal of the catheters. The sensor was tested immediately
10 after surgery (and stabilization) and then after a week, as described for the acute experiments.

When the glucose sensor was tested immediately after implantation, the sensor signal indicated the glucose concentration change during a glucose tolerance test with
15 a delay of 15 minutes, as shown in Figure 7a. The sensor's output did not match the changes in glucose as closely as in the acute experiment. This mismatch is probably a result of blood that pooled around the sensor during implantation, which reduced the permeability of
20 the sensor to glucose. This effect could be avoided if a different implantation method was used to avoid bleeding. However, even with blood contamination the sensor continued to respond to changes in glucose concentration induced by a glucose tolerance test after 1 week, Figure
25 7b. The current produced by the sensor matched the glycemia of the dog, although the sensitivity was reduced compared to the day of implantation.

Example 7

30 For long term in vivo evaluation of the glucose sensor in dogs, the sensor was connected to a Konigsberg skin button connector specially adapted for subcutaneous implantation of multiple sensors.

A sensor with a Pt/5minPPD/GOx/Nafion electrode
35 prepared as described in Example 1 was heat cured and sterilised at 120°C for 60 minutes and implanted subcutaneously in a halothane anaesthetised dog through

an incision in the back of the neck. A silastic catheter was also inserted in a jugular vein to facilitate blood sample collection.

5 The sensor was tested immediately after surgery and then at days 3, 5, 7 and 10 post-implantation. During testing, + 0.7 V was applied and the current was allowed to stabilise for 45 minutes. After this period, a bolus of glucose (0.5 g/kg body weight) was injected through the venous catheter and blood was sampled at 0, 1, 3, 5,
10 10, 15, 30, 60 and 90 minutes after glucose administration. Glucose concentration was determined in the blood samples using a Beckman Glucose Analyser II and was compared to sensor current.

The results are show in Figure 8.

15 The present invention is not limited to the features of the embodiments described herein, but includes all variations and modifications within the scope of the claims.

Table I. Sensor Response to Various Interferences.

Interferent	Concentration ^a	% error relative to 5.6mM glucose ^b		
		no PPD (n = 2)	5 min PPD (n = 5)	15 min PPD (n = 2)
Ascorbic acid	0.11 mM	5	0	0
Uric acid	0.48 mM	39	5±3	0
L. Cysteine	0.10 mM	/	poisoning	poisoning
Urea	4.30 mM	/	0	0
Fructose	0.40 mM	/	0	/
Acetaminophen	0.17 mM	/	57±29	39

- a) Interferent is added at the maximum physiological concentration in blood.
- b) Error is expressed as the apparent % increase in glucose concentration when the interferent is added to a 5.6 mM glucose, pH 7.4 buffer. The number of sensors tested is shown in brackets.

Table II. Hydrodynamic effect on sensor output.

Film coating ^a	% change without stirring ^b	(n =)
GOx/Nafion	-20±4	(n = 3)
5 min PPD/GOx/Nafion	5±1	(n = 5)
15 min PPD/GOx/Nafion	42±25	(n = 3)

- a) Films coated on Pt, needle-type sensors. PPD is poly(phenylene diamine), GOx is glucose oxidase.
- b) % change in sensor current when stirring is stopped in 20 mM glucose, pH 7.4 buffer. The number of sensors studied is shown in brackets.

Table III. In Vitro characteristics of needle-type glucose sensors^a.

Background current (nA) ^b	20 ± 7	(n = 19)
Sensitivity (nA/mM)	25 ± 10	(n = 19)
Response time (s) ^c	33 ± 13	(n = 6)

- a) 5 min PPD/Gox/Nafion coating on needle type Pt electrodes in pH 7.4 buffer.
The number of sensors studied is shown in brackets.
- b) Measured after stabilization of the background following polarization
(10-30 min).
- c) Rise to 90% response for a concentration step from 0 to 5.6 mM.

We claim:

1. An implantable sensor for sensing and measuring at least one selected component of a biological fluid or tissue comprising a reference electrode and a working electrode,
5 said working electrode comprising conducting means, an inner coating comprising a low permeability polymer film applied to said conducting means, an enzyme-immobilised layer applied over said inner coating and containing an enzyme specific for said selected component, the catalytic activity of the enzyme being indicative of said selected component, and an outer coating of a perfluorinated ionomer polymer applied over the enzyme-immobilised layer, said conducting means being capable of oxidising or reducing a product of the catalytic activity of the enzyme,
10 and said reference electrode having an outer coating of a perfluorinated ionomer polymer.
15
2. A sensor in accordance with claim 1 wherein the reference electrode comprises a silver coil/silver chloride electrode and the conducting means of the working electrode comprises a platinum coil.
20
3. A sensor in accordance with claim 2 wherein the inner coating comprises a film of poly(o-phenylene diamine).
25
4. A sensor in accordance with claim 3 wherein the enzyme-immobilised layer comprises glucose oxidase and a suitable immobilising agent.
30
5. A sensor in accordance with claim 4 wherein the perfluorinated ionomer polymer is Nafion.
35

6. A sensor in accordance with claim 5 wherein the outer coating of Nafion is applied in several layers.
7. A sensor in accordance with claim 6 wherein the film of poly(o-phenylene diamine) was electrodeposited from a solution of about 0.1 mM to about 2.0 M o-phenylene diamine for a period in the range of about 2 minutes to about 20 minutes.
- 10 8. A sensor in accordance with claim 7 wherein the immobilised enzyme layer is formed from a solution of 19.5 mg/ml glucose oxidase, 73.2 mg/ml bovine serum albumin and 5 mg/ml glutaraldehyde in acetate buffer, pH 5.5.
- 15 9. A sensor in accordance with claim 8 wherein the outer Nafion coating has a thickness in the range of about 6 μ m to about 10 μ m.
- 20 10. A sensor in accordance with claim 9 wherein the outer Nafion coating is heat cured.
11. A sensor in accordance with claim 10 wherein the Nafion coating is heat cured by heating the sensor, after fabrication, at a temperature in the range of about 110°C to about 150°C for a period in the range of about 30 minutes to about 5 hours.
- 25 12. A sensor in accordance with claim 11 wherein the heat curing is at about 120°C for about 60 minutes.
- 30 13. In a sensor for sensing and measuring at least one selected component of a biological fluid or tissue having a reference electrode and a working electrode, the improvement comprising an inner coating of poly(o-phenylene diamine) applied to said working electrode, an enzyme-immobilised layer applied over said inner coating
- 35

and containing an enzyme specific for said selected component, the catalytic activity of the enzyme being indicative of said selected component and an outer coating of a perfluorinated ionomer polymer applied over the enzyme-immobilised layer and said reference electrode having an outer coating of said perfluorinated ionomer polymer.

14. A method for preparing an implantable sensor for sensing and measuring at least one selected component of a biological fluid or tissue comprising the steps of

- (a) providing a working electrode and a reference electrode;
- (b) coating said working electrode with an inner coating comprising a low permeability polymer film;
- (c) applying over said inner coating an enzyme-immobilised layer containing an enzyme specific for said selected component, the catalytic activity of the enzyme being indicative of said selected component; and
- (d) applying an outer coating of a perfluorinated ionomer polymer over said enzyme-immobilised layer of said working electrode and over said reference electrode.

15. A method in accordance with claim 14 wherein the working electrode comprises a platinum coil, the reference electrode comprises a silver coil/silver chloride electrode, the enzyme-immobilised layer comprises glucose oxidase and a suitable immobilising agent and the perfluorinated ionomer polymer applied in step (d) is Nafion.

16. A method in accordance with claim 15 wherein step (b) comprises electrodepositing poly(o-phenylene diamine) on said working electrode from a solution of

about 0.1 mM to about 2.0 M o-phenylene diamine for a period in the range of about 2 to about 20 minutes;

5 step (c) comprises passing the working electrode through a drop of a solution containing 19.5 mg/ml glucose oxidase, 73.2 mg/ml BSA and 5 mg/ml glutaraldehyde in acetate buffer, pH 5.5.

and step (d) comprises dipping the working electrode coated in step (c) and the reference electrode into a solution of Nafion.

10

17. A method in accordance with claim 15 wherein step (d) comprises applying said outer coating in a plurality of layers, by repeatedly dipping the working electrode of step (c) and the reference electrode into a solution of Nafion until a desired thickness of outer coating is obtained.

18. A method in accordance with claim 15 wherein step (d) comprises applying said outer coating in a plurality of layers, by dipping the working electrode of step (c) and the reference electrode successively into a series of solutions of Nafion of increasing concentrations.

25 19. A method in accordance with claim 18 wherein step (b) comprises electrodepositing poly(o-phenylene diamine) from a solution of about 5 mM o-phenylene diamine for about 5 minutes; and step (d) comprises dipping the working electrode of step (c) and the reference electrode in succession once into a 0.5% solution of Nafion, once into a 3% solution of Nafion and four times into a 5% solution of Nafion to give a Nafion coating of about 10 μ m thickness.

35 20. A method in accordance with claim 19 further comprising the step of heat curing the Nafion coating.

21. A method in accordance with claim 20 wherein the step of heat curing the Nafion coating is effected by heating the sensor at a temperature in the range of about 110°C to about 150°C for a period in the range of about
5 30 minutes to about 5 hours.
22. A method in accordance with claim 21 wherein the sensor is heated at about 120° for about 60 minutes.

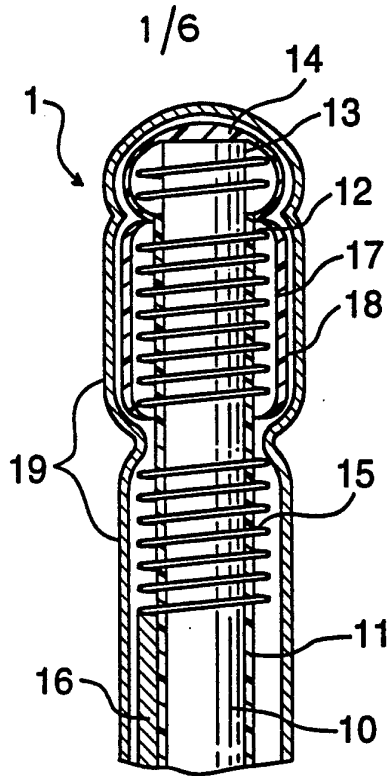

FIG.1.

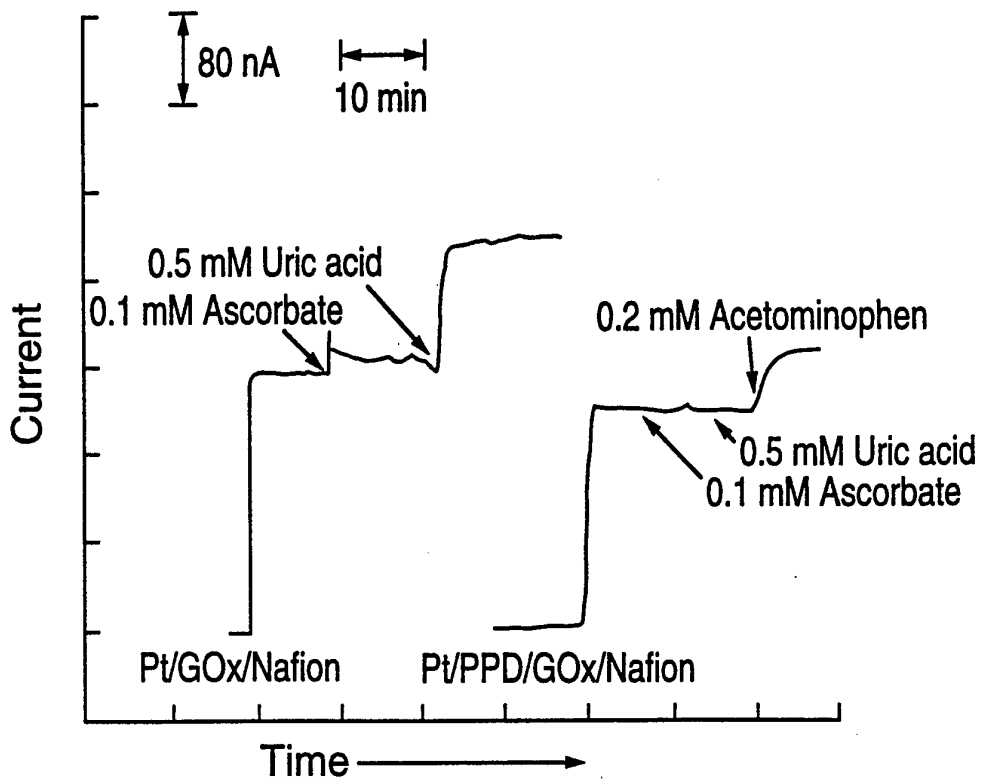

FIG.2.

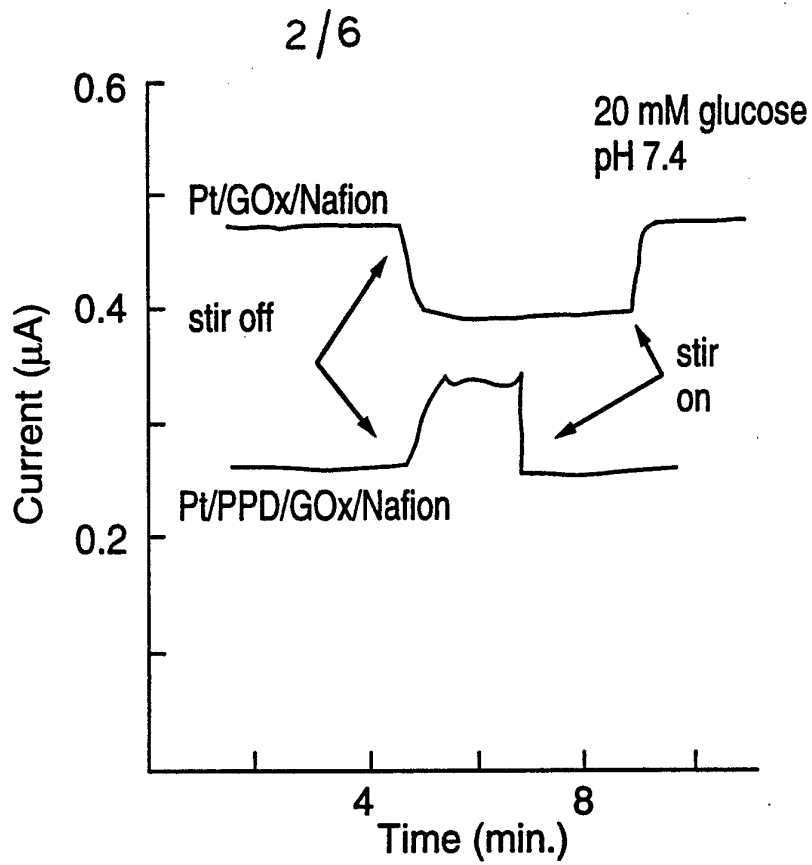

FIG.3.

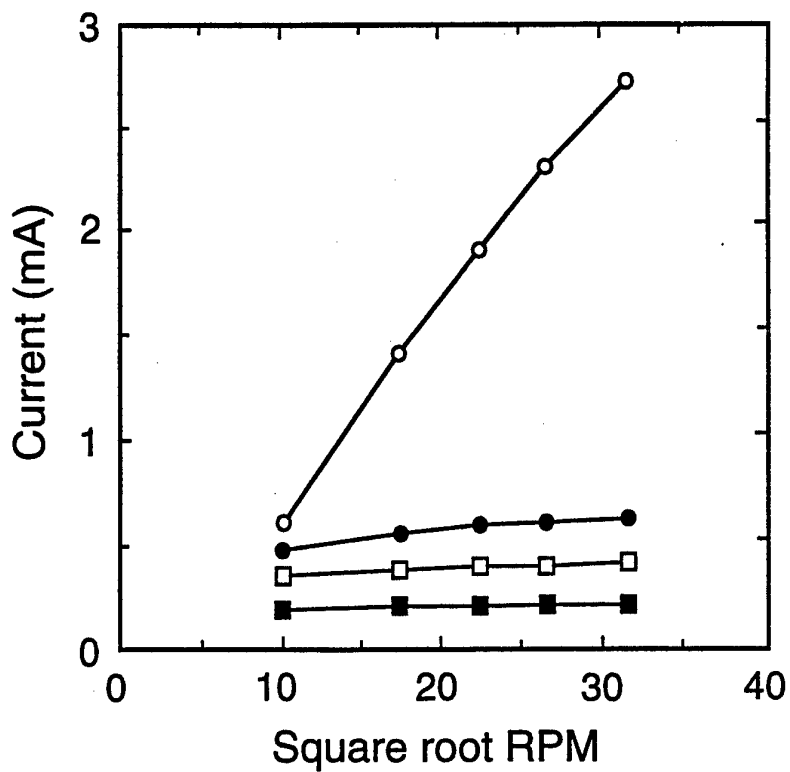

FIG.4.

SUBSTITUTE SHEET

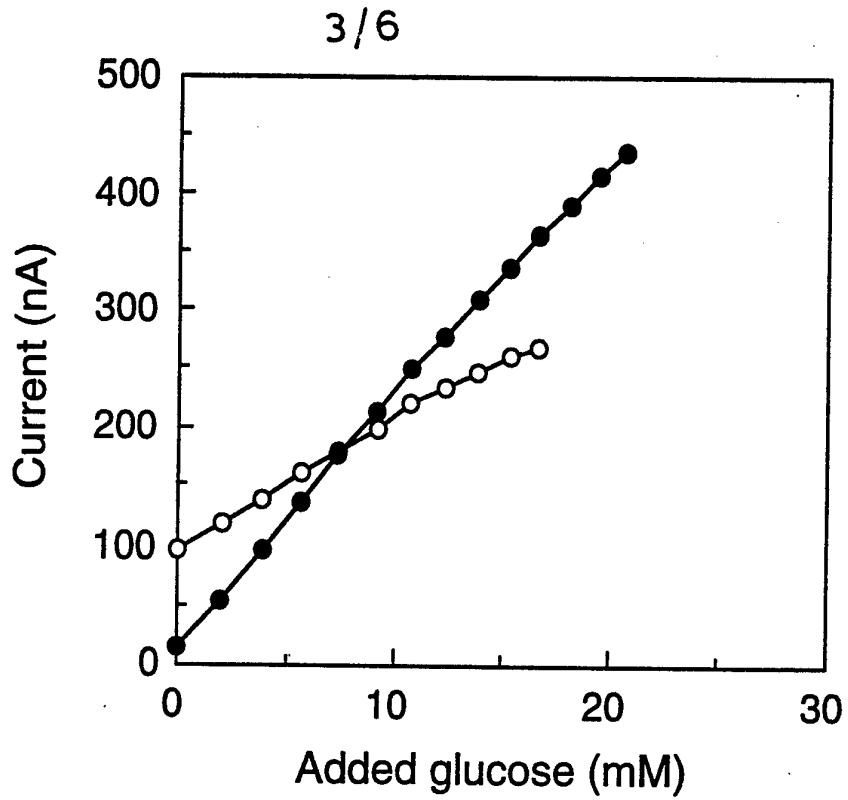

FIG.5.

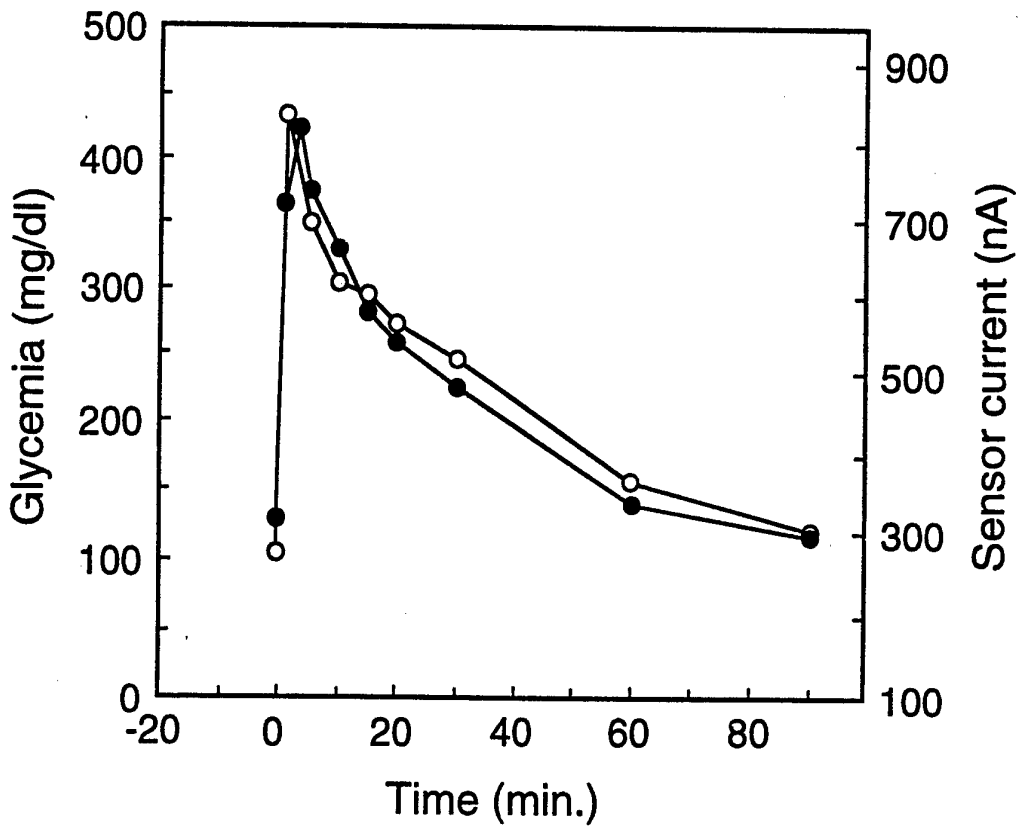

FIG.6.
SUBSTITUTE SHEET

4/6
(a) Day 1

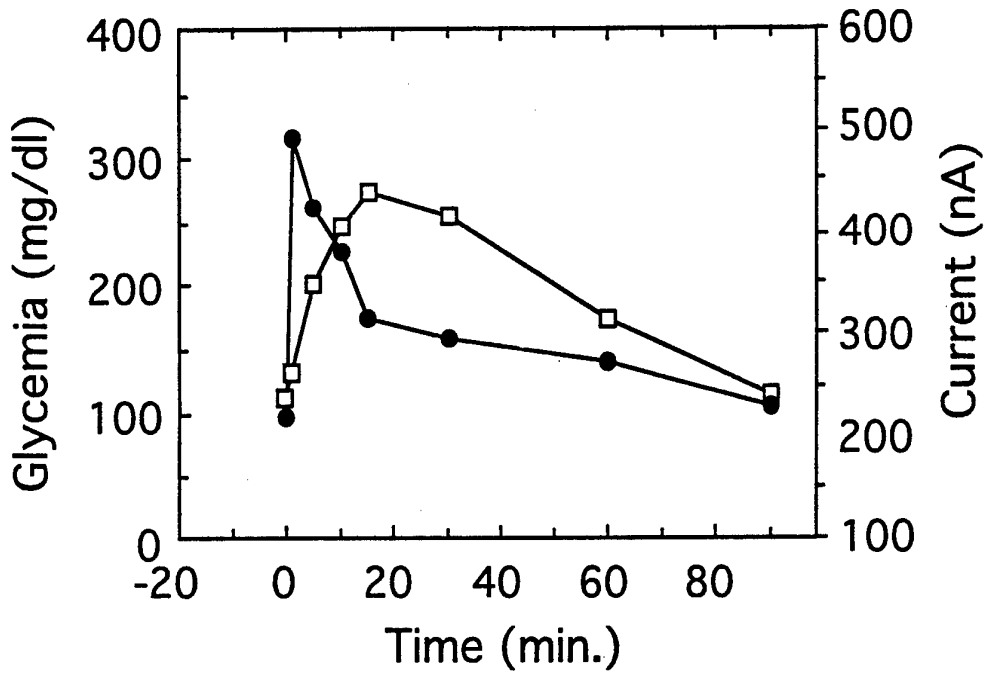

FIG.7 A.

(b) Day 7

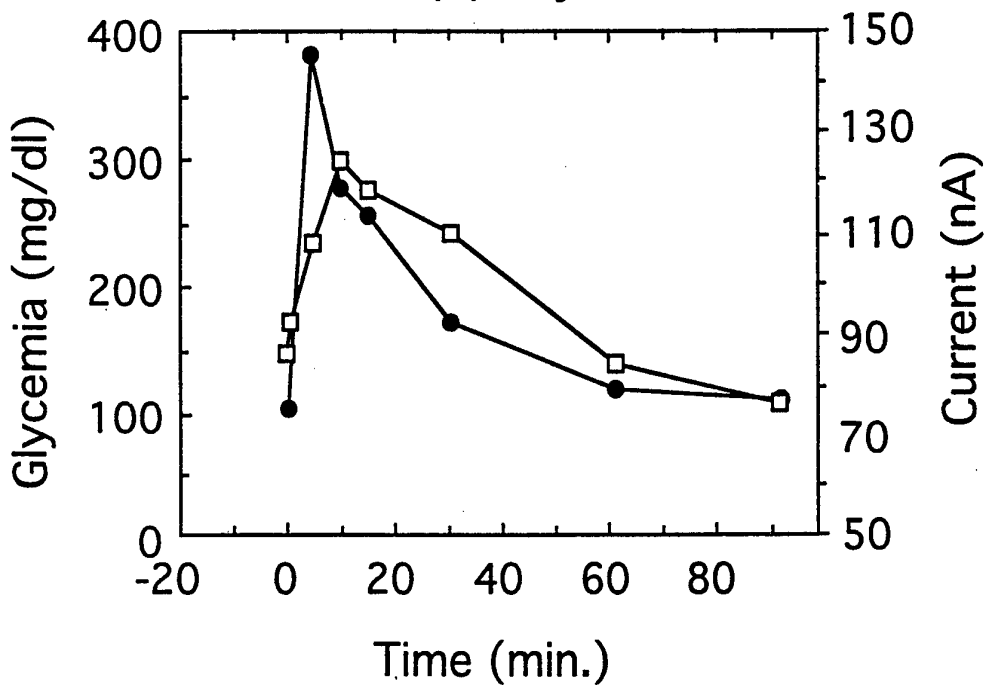

FIG.7 B.

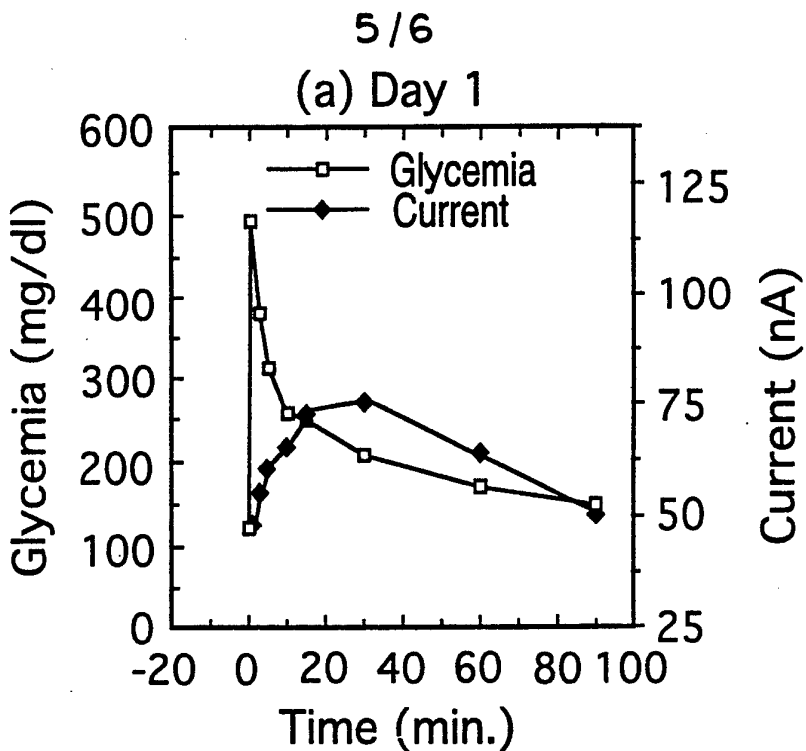

FIG.8A.

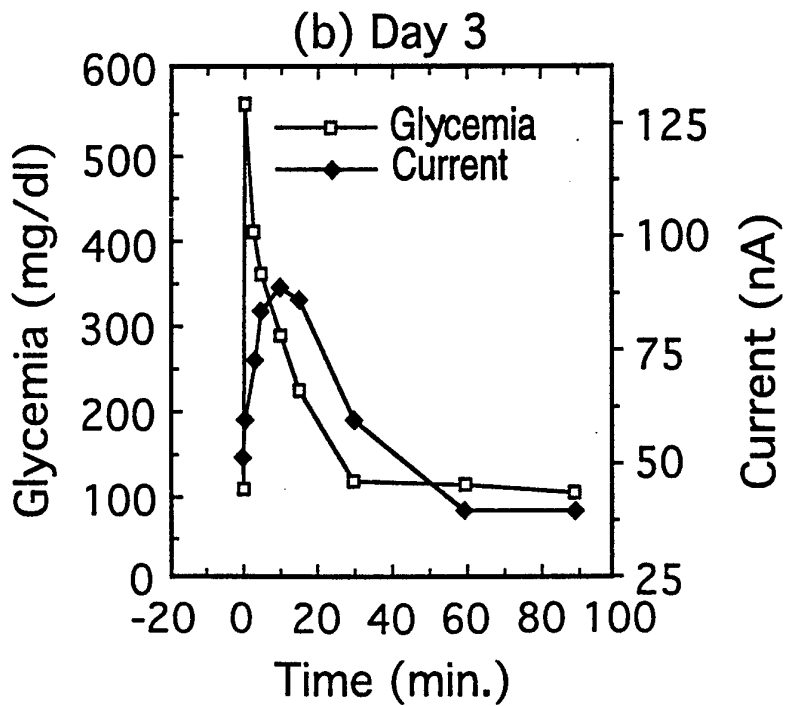

FIG.8B.

SUBSTITUTE SHEET

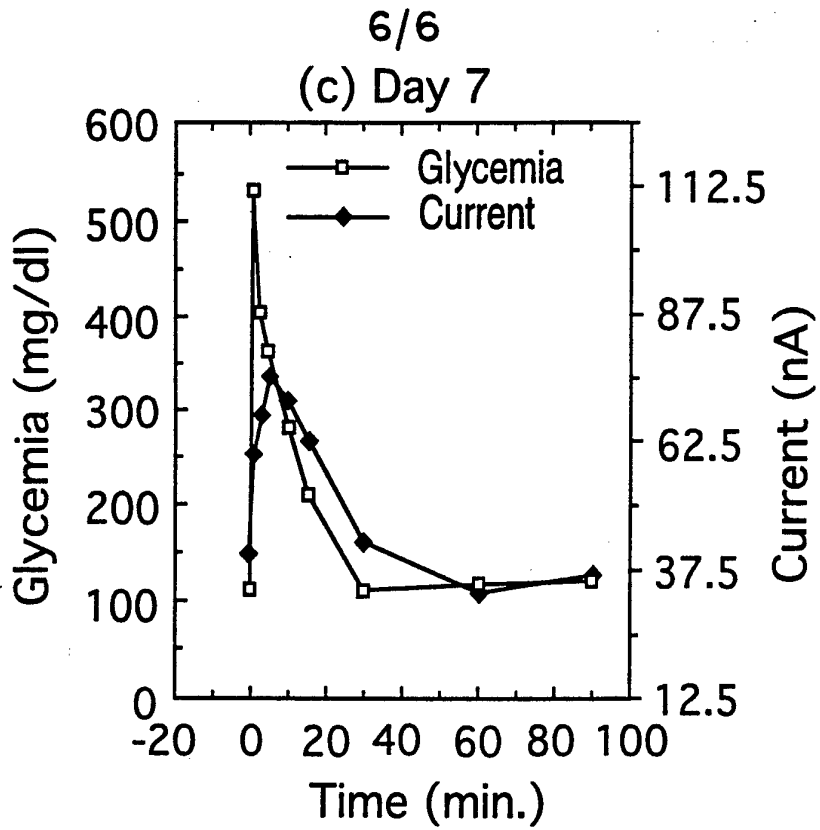

FIG.8C.

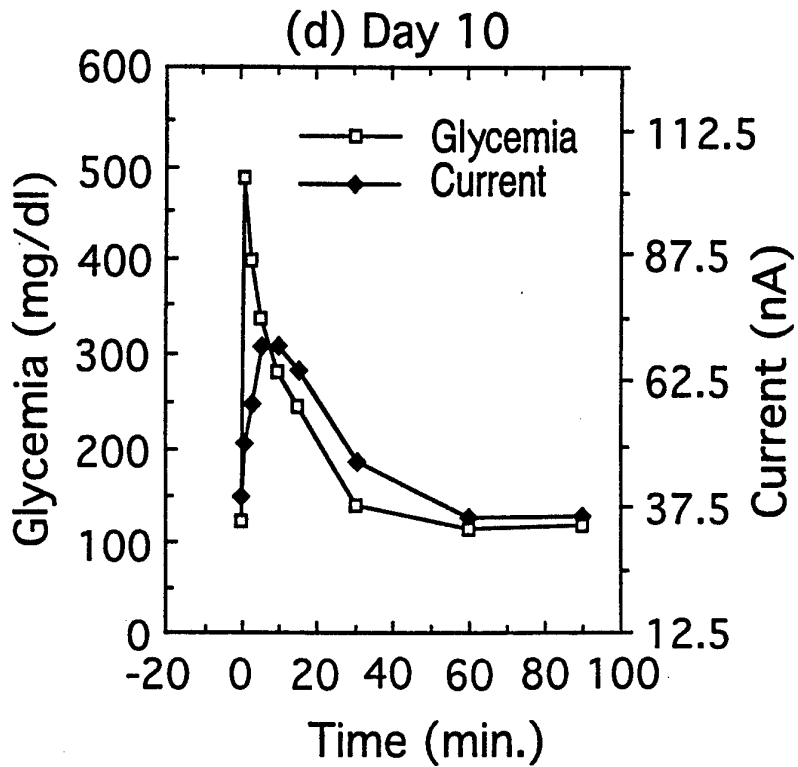

FIG.8D.

INTERNATIONAL SEARCH REPORT

International Application No

PCT/CA 94/00107

A. CLASSIFICATION OF SUBJECT MATTER
 IPC 5 C12M1/40 C12Q1/54 A61B5/00 G01N27/327

According to International Patent Classification (IPC) or to both national classification and IPC

B. FIELDS SEARCHED

Minimum documentation searched (classification system followed by classification symbols)
 IPC 5 C12Q A61B C12M G01N

Documentation searched other than minimum documentation to the extent that such documents are included in the fields searched

Electronic data base consulted during the international search (name of data base and, where practical, search terms used)

C. DOCUMENTS CONSIDERED TO BE RELEVANT

Category *	Citation of document, with indication, where appropriate, of the relevant passages	Relevant to claim No.
A	ANALYTICAL CHEMISTRY. vol. 63, no. 17 , 1 September 1991 , COLUMBUS US pages 1692 - 1696 DILBIR S. BINDRA ET AL. 'Design and in Vitro Studies of a Needle-Type Glucose Sensor for Subcutaneous Monitoring' cited in the application see the whole document <div style="text-align: center;">--- -/--</div>	1-22

Further documents are listed in the continuation of box C.

Patent family members are listed in annex.

* Special categories of cited documents :

- *A* document defining the general state of the art which is not considered to be of particular relevance
- *E* earlier document but published on or after the international filing date
- *L* document which may throw doubts on priority claim(s) or which is cited to establish the publication date of another citation or other special reason (as specified)
- *O* document referring to an oral disclosure, use, exhibition or other means
- *P* document published prior to the international filing date but later than the priority date claimed

- *T* later document published after the international filing date or priority date and not in conflict with the application but cited to understand the principle or theory underlying the invention
- *X* document of particular relevance; the claimed invention cannot be considered novel or cannot be considered to involve an inventive step when the document is taken alone
- *Y* document of particular relevance; the claimed invention cannot be considered to involve an inventive step when the document is combined with one or more other such documents, such combination being obvious to a person skilled in the art.
- *&* document member of the same patent family

Date of the actual completion of the international search

31 May 1994

Date of mailing of the international search report

08.06.94

Name and mailing address of the ISA
 European Patent Office, P.B. 5818 Patentlaan 2
 NL - 2280 HV Rijswijk
 Tel. (+ 31-70) 340-2040, Tx. 31 651 epo nl,
 Fax: (+ 31-70) 340-3016

Authorized officer

Döpfer, K-P

INTERNATIONAL SEARCH REPORT

International Application No
PCT/CA 94/00107

C.(Continuation) DOCUMENTS CONSIDERED TO BE RELEVANT		
Category	Citation of document, with indication, where appropriate, of the relevant passages	Relevant to claim No.
A	ANALYTICAL CHEMISTRY vol. 60, no. 19 , 1 October 1988 , COLUMBUS US pages 2002 - 2007 D. JED HARRISON ET AL. 'Characterization of Perfluorsulfonic Acid Polymer Coated Enzyme Electrodes and a Miniaturized Integrated Potentiostat for Glucose Analysis in Whole Blood' cited in the application see the whole document ---	1-22
A	BIOMEDICA ET BIOCHIMICA ACTA vol. 45, no. 6 , June 1986 , BERLIN DE pages 769 - 777 A. MÜLLER , P. ABEL AND U. FISCHER 'Kontinuierliche Messung der Glukosekonzentration im subkutanen Gewebe mit implantierbaren Enzymelektroden' see the whole document ---	1-22
A	DIABETES CARE vol. 9, no. 3 , May 1986 , NEW YORK, NY, US pages 298 - 301 MOTOAKI SHICHIRI ET AL. 'Telemetry Glucose Monitoring Device with Needle-Type Glucose Sensor: A Useful Tool for Blood Glucose Monitoring in Diabetic Individuals' cited in the application see the whole document ---	1-22
A	ANALYTICAL CHEMISTRY vol. 62, no. 11 , 1 June 1990 , COLUMBUS US pages 1111 - 1117 SYLVIA V. SASSO ET AL. 'Electropolymerized 1,2-Diaminobenzene as a Means To Prevent Interferences and Fouling and To Stabilize Immobilized Enzyme in Electrochemical Sensors' cited in the application see the whole document ---	1-22
A	US,A,4 517 291 (JAMES L. SEAGO) 14 May 1985 see the whole document ---	1-22
A	WO,A,90 13021 (NATIONAL RESEARCH DEVELOPMENT CORPORATION) 1 November 1990 see the whole document ---	1-22
	-/--	

1

INTERNATIONAL SEARCH REPORT

International Application No

PCT/CA 94/00107

C.(Continuation) DOCUMENTS CONSIDERED TO BE RELEVANT		
Category	Citation of document, with indication, where appropriate, of the relevant passages	Relevant to claim No.
A	<p>WO,A,91 15993 (THE UNIVERSITY OF KANSAS; UNIVERSITE PARIS VAL DE MARNE; INSERM) 31 October 1991 see the whole document ---</p>	1-22
A	<p>EP,A,0 025 110 (TOKYO SHIBAURA DENKI KABUSHIKI KAISHA) 18 March 1981 see the whole document ---</p>	1-22
A	<p>NATURE. vol. 214 , 3 June 1967 , LONDON GB pages 986986 - 988 S.J. UPDIKE AND G.P. HICKS 'The Enzyme Electrode' see the whole document ---</p>	1-22
A	<p>DIABETOLOGIA vol. 30 , 1987 , BERLIN, DE pages 940 - 945 U. FISCHER ET AL. 'Assessment of subcutaneous glucose concentration: validation of the wick technique as a reference for implanted electrochemical sensors in normal and diabetic dogs' cited in the application see page 941, right column, line 24 - page 942, left column, line 8 ---</p>	1-22
A	<p>DIABETOLOGIA vol. 24 , 1983 , BERLIN, DE pages 179 - 184 M. SHICHIRI ET AL. 'Glycaemic Control in Pancreatectomized Dogs with a Wearable Artificial Endocrine Pancreas' cited in the application see page 179, right column, line 10 - page 180, left column; figure 1 ---</p>	1-22
A	<p>DIABETOLOGIA vol. 35, no. 3 , March 1992 , BERLIN, DE pages 224 - 230 D. MOATTI-SIRAT ET AL. 'Towards continuous glucose monitoring: in vivo evaluation of a miniaturizrd glucose sensor implanted for several days in rat subcutaneous tissue' cited in the application see page 224, left column, line 6 - page 225, right column, line 14; figure 1 -----</p>	1-22

INTERNATIONAL SEARCH REPORT

Information on patent family members

International Application No
PCT/CA 94/00107

Patent document cited in search report	Publication date	Patent family member(s)	Publication date
US-A-4517291	14-05-85	US-A- 4604182	05-08-86
WO-A-9013021	01-11-90	GB-A- 2230865	31-10-90
WO-A-9115993	31-10-91	US-A- 5165407	24-11-92
		AU-A- 7782891	11-11-91
		AU-B- 640785	02-09-93
		EP-A- 0525127	03-02-93
EP-A-0025110	18-03-81	JP-C- 1365389	26-02-87
		JP-A- 56027643	18-03-81
		JP-B- 61029667	08-07-86
		US-A- 4388166	14-06-83