



(51) International Patent Classification:
H01R 13/187 (2006.01)

(21) International Application Number:
PCT/IB2008/055608

(22) International Filing Date:
10 September 2008 (10.09.2008)

(25) Filing Language: English

(26) Publication Language: English

(71) Applicant (for all designated States except US): FCI [FR/FR]; 145/147, rue Yves le Coz, F-78000 Versailles (FR).

(72) Inventors; and

(75) Inventors/Applicants (for US only): CASSES, Claude [FR/FR]; 8, Rue du Marché, F-28300 Clevilliers (FR). CAPPE, Patrice [FR/FR]; 7 Route de Rambouillet, F-28210 Faverolles (FR). DAVID, Jean-Paul [FR/FR]; 15, Rue de l'Ecole, F-28300 Cintray (FR). MULOT, Gérard [FR/FR]; 26, rue du Général de Gaulle, F-28210 Nogent Le Roi (FR).

(74) Agent: REGI, François-Xavier; FCI - IP Department, 145, rue Yves Le Coz, F-78035 Versailles Cedex (FR).

(81) Designated States (unless otherwise indicated, for every kind of national protection available): AE, AG, AL, AM, AO, AT, AU, AZ, BA, BB, BG, BH, BR, BW, BY, BZ, CA, CH, CN, CO, CR, CU, CZ, DE, DK, DM, DO, DZ, EC, EE, EG, ES, FI, GB, GD, GE, GH, GM, GT, HN, HR, HU, ID, IL, IN, IS, JP, KE, KG, KM, KN, KP, KR, KZ, LA, LC, LK, LR, LS, LT, LU, LY, MA, MD, ME, MG, MK, MN, MW, MX, MY, MZ, NA, NG, NI, NO, NZ, OM, PG, PH, PL, PT, RO, RS, RU, SC, SD, SE, SG, SK, SL, SM, ST, SV, SY, TJ, TM, TN, TR, TT, TZ, UA, UG, US, UZ, VC, VN, ZA, ZM, ZW.

(84) Designated States (unless otherwise indicated, for every kind of regional protection available): ARIPO (BW, GH, GM, KE, LS, MW, MZ, NA, SD, SL, SZ, TZ, UG, ZM, ZW), Eurasian (AM, AZ, BY, KG, KZ, MD, RU, TJ, TM), European (AT, BE, BG, CH, CY, CZ, DE, DK, EE, ES, FI, FR, GB, GR, HR, HU, IE, IS, IT, LT, LU, LV, MC, MT, NL, NO, PL, PT, RO, SE, SI, SK, TR), OAPI (BF, BJ, CF, CG, CI, CM, GA, GN, GQ, GW, ML, MR, NE, SN, TD, TG).

Published:

— with international search report (Art. 21(3))

(54) Title: ELECTRICAL CONTACT, SET OF ELECTRICAL CONTACT, PRODUCT AND ASSEMBLY COMPRISING SUCH AN ELECTRICAL CONTACT, ITS METHOD OF MANUFACTURE AND METHOD OF ELECTRICAL CONNECTION

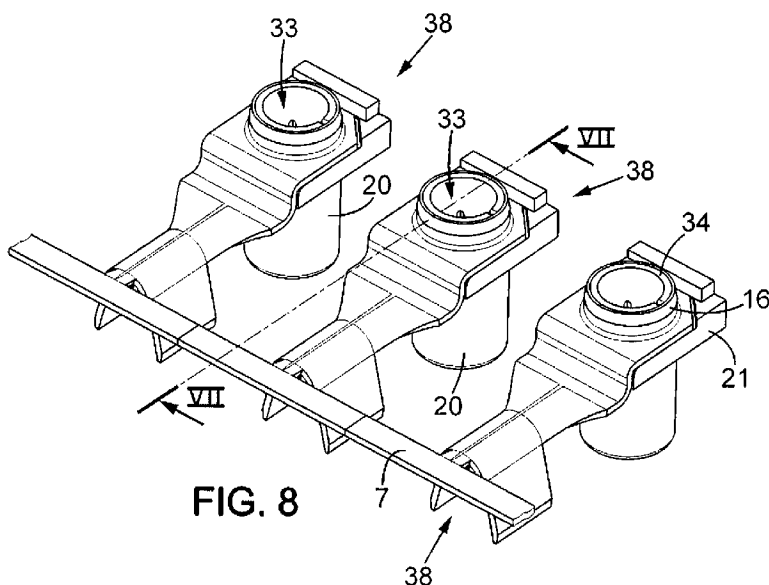

(57) Abstract: The electrical contact comprises a wire crimping portion receiving an electrical wire, a circumferential power contact portion (33) for connection with a complementary contact. The power contact portion comprises a body mechanically retained on the wire crimping portion and spring legs (35) extending from the body and to be contacted with the complementary contact. The electrical contact further comprises an electrically insulating cover (20) covering said spring legs (35).



ELECTRICAL CONTACT, SET OF ELECTRICAL CONTACT, PRODUCT AND ASSEMBLY COMPRISING SUCH AN ELECTRICAL CONTACT, ITS METHOD OF MANUFACTURE AND METHOD OF ELECTRICAL CONNECTION

5 FIELD OF THE INVENTION

The instant invention relates to electrical contacts, sets of electrical contacts, for instance for connector used in motorized vehicles, products and assemblies comprising such electrical contacts, their
10 methods of manufacture and methods of electrical connection.

BACKGROUND OF THE INVENTION

Electrical connectors are used for connecting electrical appliances together. For example, in the
15 automotive industry, electrically powered cars (or partly electrically powered cars, such as so-called "hybrid" cars) are emerging as an interesting alternative to the fuel-only vehicles. This requires new generations of connectors for supplying electrical motors with higher voltages than those
20 required for appliances such as window-lifters, radio, etc...).

A certain class of electrical connectors usable in this context is made as an electrically insulating housing comprising three ways. In each of these ways, an electrical
25 contact which is crimped on a cable is inserted.

An example of electrical contact is describes for instance in DE 1 02 11 634. This contact comprises a wire crimping portion crimped on an electrical wire and a power contact portion having a cylindrical shape for
30 accommodating a complementary contact. The power contact portion is provided with a barrel with a plurality of contact blades elastically curved toward the central and longitudinal axis of the cylindrical power contact portion.

After its crimping on the wire, this contact is
35 integrally incorporated in an insulating plastic housing

comprising two separate top and bottom parts mechanically locked to one another.

The instant invention has notably for object to make easier the manufacturing of such a contact.

5 SUMMARY OF THE INVENTION

To this aim, it is provided an electrical contact according to claim 1.

10 With these features, the electrical contact is provided with a plurality of spring legs integral with the power contact portion. This ensures direct paths for the current as well as a large surface of electrical connection between the contact and its mating contact. Further, a cover will protect the spring legs against any damage that might occur during handling, transportation or storage
15 occurring between the manufacturing of the contact, and its insertion in the housing. Thought, the number of parts of the contact is reduced with regard to the contact disclosed in DE 1 02 11 634, making the manufacturing process easier.

20 In some embodiments, one might also use one or more of the features as defined in the dependent claims.

Such contacts could alternatively be used for other applications than the electrical automotive application.

BRIEF DESCRIPTION OF THE DRAWINGS

25 Other characteristics and advantages of the invention will readily appear from the following description of one of its embodiments, provided as a non-limitative example, and of the accompanying drawings.

On the drawings:

30 - Fig. 1 is a schematic representation of a manufacturing apparatus,

- Fig. 2 is a perspective view of a product obtained at the output of the crimping portion forming station of the apparatus of Fig. 1,

35 - Fig. 3 is another partial perspective of the product of Fig. 2,

- Fig. 4a is a perspective view with roughly the same orientation as Fig. 2 of a cover according to a first embodiment,

5 - Fig. 4b is another perspective view of the cover of Fig. 4a,

- Fig. 5 is a perspective view of the product output from a first assembly station of the apparatus of Fig. 1,

10 - Fig. 6 is a perspective view of a product output from a power contact portion forming station of the apparatus of Fig. 1,

- Fig. 7 is a partial sectional view of an electrical contact obtained from the apparatus of Fig. 1, taken along line VII-VII of Fig. 8,

15 - Fig. 8 is a perspective view of a product output from the apparatus of Fig. 1,

- Fig. 9 is an exploded view of an electrical connector assembly incorporating electrical contacts,

20 - Fig. 10 is a sectional view along line X-X on Fig. 9 of a fool-proofing body of an electrical connector of the assembly of Fig. 9,

- Fig. 11a is a rear view of the three covers used in the connector of Fig. 9,

25 - Fig. 11b is a schematic cross section of the three fool-proofing bodies of the connector of Fig. 9, and

- Fig. 12 is a sectional view along line X-X on Fig. 9, of the partly assembled electrical connector assembly.

30 On the different figures, the same reference signs designate like or similar elements.

DETAILED DESCRIPTION

Fig. 1 schematically shows an apparatus 1 for the manufacture of an electrical contact. The apparatus comprises, for example, a crimping portion forming station 2, a first assembly station 3, a power contact portion 35

forming station 4 and a second assembly station 5. The crimping portion forming station 2, the first assembly station 3 and the second assembly station 5 are for example disposed in line and adapted to perform series of operations continuously on a blank 6 of material. The blank 6 is for example provided in a shape of a continuous strip 7 to which are connected, through respective connecting portions 8, pieces 9 to be formed. These pieces 9 are electrically conducting, for example metallic or of a metallic alloy such as a copper alloy. For example, the blank 6 as represented on Fig. 1 was previously obtained by forming from a plane conductive thin plate.

The crimping portion forming station 2 needs not to be described in more details. It is sufficient to explain that it is suitable for forming, from each piece 9, the first piece 10 as shown on Fig. 2 and 3.

This first piece 10 comprises a wire crimping portion 11 which is directly connected to the strip 7 through the connection portion 8, and a retention portion 12 which will be described in detail.

The wire crimping portion 11 comprises a partly cylindrical barrel 13 of axis X, from which extend upwardly and outwardly on Fig. 3 two crimping wings 14, which, at this stage of the manufactured process, are still in the uncrimped configuration. The barrel 13 and the crimping wings 14 together define a receiving space 15 for receiving the end of an electrical wire extending along a first longitudinal direction identical to the axis X.

The retention portion 12 comprises a flat platform or flange 60 from which a mechanical retention feature 16 projects upwardly. In the present example, it is shaped as a ring 16 extending circumferentially about a second longitudinal axis Y. In the present example, the axis Y is orthogonal to a plane defined by the first longitudinal direction X and the direction Z of extension of the strip

7. However, the present invention could be used also for other orientations of the second longitudinal axis Y, in particular when the axis Y is parallel to the axis X.

The platform 60 also comprises a second mechanical retention feature 17, which is, in the present example, performed as a tab 17 at the end of the platform 60 opposite to the end of the piece 10 connected to the strip 7.

An intermediate portion 18 is provided between the wire crimping portion 11 and the retention portion 12 for connecting these two portions together. This intermediate portion 18 can for example be designed as a stepped portion for placing the ring 16 in a plane above the wire crimping portion 11. Yet, other geometries are possible, which will depend on the configuration of the electrical connector, and the available space.

In the apparatus of Fig. 1, the product of Fig. 2 and 3 exits the crimping portion forming station 2 to enter a first assembly station 3. This station also comprises a dispenser 19 (see Fig. 1) of covers 20. One embodiment of a cover is shown on Figs. 4a and 4b. The first assembly station 3 is adapted to assemble a cover 20 to each of the first pieces 10 as obtained from the crimping portion forming station and as shown on Figs. 2 and 3.

The covers 20 are made of an electrically insulating material such as, for example, a suitable plastic and might have been moulded to the shape shown on Figs. 4a and 4b. Each cover 20 comprises a connecting portion 21 which is for example designed as a platform extending mainly in the reference plane P formed by the axis X and Z, and a protecting portion 22 comprising a cylindrical body 23 and a collar 24. The top end of the cylindrical body is connected to the bottom face of the platform 21, whereas the collar 24 is formed at the bottom end of the body 23. The cylindrical body extends along the

longitudinal axis Y and has an external wall 23a and an internal wall 23b which defines an inside space 25.

The rear end of the platform 21 comprises two legs 26 symmetrical with respect to the X axis and which define, between them, an insertion opening 27. The two legs 26 are connected together by a bridge 28 which extends over the insertion opening 27. The insertion opening 27 comprises a first narrow space 29a and a broad space 29b closer to the axis of the cylindrical body, so that faces 30, which face frontward, define mechanical locking features for engagement with complementary mechanical locking feature of the connector (to be explained later in relation to Fig. 10).

The bridge 28 comprises a downward facing face 31 which defines a mechanical locking feature with the first piece 10 as will be explained below in relation to Fig. 7.

The lateral sides 32 of the bridge 28 are provided with specific geometrical features to provide a fool-proofing feature for engagement with a complementary fool-proofing feature of the connector, as will be explained later in relation to Figs. 10 to 11b.

In the first assembly station 3, the cover 20 which has just been described is assembled with the first piece 10 which was described before, by any suitable way. For example, as shown on Fig. 5, the cover is slid along the axis X toward the first piece 10. The tab 17 of the retention portion 12 of the first piece 10 is inserted in the space 29a and 29b until the top face of the tab 17 is in contact with the downward facing face 31 of the bridge 28 (see also Fig. 7). The top face of the platform 21 is thus below the bottom face of the platform 60 of the first piece 10.

Referring back to Fig. 1, a second blank 106 is introduced into the power contact portion forming station 4 of the apparatus 1. The second blank 106 is, for example,

of similar design as the blank 6, and comprises a strip 107 extending along a longitudinal direction Z and to which pieces 109 are connected through connecting portions 108. However, other embodiments are possible. The power contact portion forming station 4 is suitable to form any of the pieces 109 to a power contact portion 33 such as shown on Fig. 6. Such a power contact portion is for example obtained by forming (stamping) a flat piece 109 and then rolling it to the desired geometry, or by any other suitable way.

As shown on Fig. 6, the power contact portion 33 is a cylinder of circular cross-section and comprises a body 34 from which extend a plurality of (for example 8) spring legs 35 sensibly along the longitudinal axis Y. The legs 35 extend sensibly downward from the body 34 and inward toward a point of contraflexure 36 from which they are flared outward to their tip. The internal face at the point of contraflexure forms a protrusion which projects inside an internal space 61 for receiving a complementary electrical contact therein. This complementary electrical contact is preferably of diameter greater than the internal diameter of the power contact portion 33 at the level of the protrusions so that the legs will be resiliently biased in contact with this complementary electrical contact upon its insertion in the internal space.

In the present example where the power contact portion 33 is manufactured from rolling a metal blank, a gap 37 may exist between the two longitudinal edges which are brought close to each other during the rolling operation. This gap 37 may be closed, for example, by welding, or by any other suitable means.

Referring back to Fig. 1, the product, shown on Fig. 5, comprising a strip of first pieces 10 of metal carrying a respective cover, is moved from the first assembly station 3 to the second assembly station 5.

Simultaneously, the power contact portion 33 is moved from the power contact portion forming station 4 to the second assembly station 5 to be inserted along the axis Y, from the top, through the ring 16 and the cover 20. The external surface of the body 34 biases in electrical contact with the inner face of the ring 16 for electrical communication between these two pieces. The spring legs 35 are totally enclosed in the cover 20. The body 34 can be welded, if necessary, to the ring 16, or only retained by friction, or any other means. It should be noted that, after the power contact portion 33 has been inserted, it is no longer possible to remove the cover 20 from the electrical contact by sliding along direction X.

Fig. 8 shows the product which is output from the second assembly station 5 shown schematically on Fig. 1. This product comprises a longitudinal strip 7 to which are connected a plurality of electrical contacts 38. For example, the electrical contacts 38 are all identical. In another example, these electrical contacts 38 have different covers having different colours and/or fool-proofing features (see below Figs. 11a and 11b for more details about this). The product shown on Fig. 8 can be provided to a third party for cable assembly and terminal insertion in connectors. In alternative, the individual electrical contacts 38 could be separated from the strip 7 before being provided to a cable assembler or a harness maker. As an alternative, the electrical contacts are not necessarily manufactured as two separate conductive pieces. An integral piece comprising a power contact portion and a wire crimping portion might be used.

An example of a suitable connector for use with the electrical contacts as described above is shown in exploded partial view on Fig. 9. Fig. 9 shows a first electrical connector 39 and a second complementary electrical connector 139 to be mated with.

The first electrical connector 39 is for example made as a dielectric housing 40 defining a plurality of pathways 41a, 41b, 41c which are electrically isolated from one another and extend with a right angle (between axis X and axis Y). Namely, a first end of these openings is provided on a front face of the connector 39, while a second end thereof is provided on its bottom face (not visible on Fig. 9), facing the second connector 139.

As shown on the left side of Fig. 9, three electrical contacts 38a, 38b, 38c are provided which are manufactured according to the above mentioned process. These three terminals differ from one another by each having a different cover 20a, 20b, 20c. The wire crimping portion 11 of each electrical contact is crimped on a respective electrical wire 42 for placing the wire in electrical communication with the electrical contact 38. This can, for example, be performed by folding the crimping wings of the electrical contact on the wire, with a suitable tool comprising a stamping element and an anvil. An insulating joint 43 is slid along the sheath of each wire 42 to the position of Fig. 9 and a grid 44 is placed by inserting the wire 42 through the respective openings 45 of the grid. The grid has locks 46 for engagement with complementary locks 47 of the first connector 39 to lock the grid onto the first connector 39. In this locked position, the joints 43 are circumferentially pressed by internal walls 48 of the first connector 39, and longitudinally pressed between the grid 44 and respective fool-proofing bodies 49 of the respective pathway 41. This will be described in relation to Fig. 10.

The electrical contact 38 is mechanically retained in the housing 40 of the first connector by mechanical engagement of the hook 54 with the faces 30 of the cover (see Fig. 4a).

Referring back to Fig. 9, the second electrical

connector 139 may for example comprise three cylindrical chimneys 50, cylindrical of circular cross-section of diameter greater than the outer diameter of the covers 20. An electrical contact 51 is provided for each respective chimney 50. These electrical contacts 51 may, for example, comprise a first end 51a which extends in the chimney 50, and an opposite second end 51b for connection to an electrical appliance.

Fig. 10 shows a sectional view through the pathway 41b. Only the fool-proofing body 49b delimiting this pathway is depicted. As explained above, this body 49 has an aperture 52 on the one hand, for receiving the electrical contact 38, and another aperture 53 in its bottom face for receiving the electrical contact 51 of the complementary connector. A locking tool 54 is provided on the back face of the body 49b, for example as a hook extending from this back face toward the aperture 52 and having a catching portion 55 born by a resilient arm 56.

The body 49b has a fool-proofing relief 57 in the top left corner of its profile, which is provided with a given geometry. The body 49b is for example made from moulded plastic and may for example be provided with a pigment of a first colour.

It is locked to the housing 40 of the first electrical connector through any suitable means, such as spring lances 58 which engage with complementary features 59 (Fig. 12) of the internal faces of the housing 40.

As shown on Fig. 11a and 11b, each of the covers 20 has a different fool proofing feature 32 with a specific geometry. Further, although this is not visible on Fig. 11a, each of the covers may incorporate a respective pigment so that they all have different colours. As shown on Fig. 11b, the fool-proofing bodies 49 all have a different fool proofing geometry 57. Further, they all include a different pigment, which provides different

colours. For example, the colour of one of the bodies 49 is associated to, preferably is the same as, the colour of a respective cover. Further, the geometries 32 and 57 are chosen so that, among the three covers of Fig. 11a, only one can enter a respective body 49, and is prevented to enter the other bodies. Further, each body can receive only one of the covers. Preferably, the cover which is allowed to be inserted in a respective box is provided with a colour associated to the colour of that box.

10 The connector assembly is shown on Fig. 12 with the complementary connector 139 partly assembled. As shown, each electrical contact 38 is a right-angled contact in that its two connection axes X and Y are perpendicular to one another. The cover 20 is guided into a respective chimney 50 and the complementary electrical contact 51 is placed in electrical contact with the power contact portion 33 of the electrical contact 38.

CLAIMS

1. An electrical contact comprising:

5 - a wire crimping portion (11) comprising a receiving space (15) adapted for receiving an electrical wire, and at least one wing (14) adapted to be crimped on an electrical wire received in the receiving space,

 - a circumferential power contact portion (33) electrically connected with the wire crimping portion (11),
10 and defining a connecting space (61) for connection with a complementary contact,

 said power contact portion (33) comprising:

 - a body (34) mechanically retained on the wire crimping portion, and

15 - a plurality of spring legs (35), each extending from the body, to be contacted with the complementary contact,

 the electrical contact further comprising an electrically insulating cover (20) mechanically retained on
20 one portion chosen among the wire crimping portion (11) and the power contact portion (33), and covering said spring legs (35).

2. Electrical contact according to claim 1, comprising a first electrically conductive piece (10)
25 comprising the wire crimping portion (11), and a second distinct electrically conductive piece comprising the power contact portion (33),

 wherein the first and second pieces comprise a respective first (16) and second locking portions (34),
30 said first and second locking portions being adapted to engage each other to lock said first and second pieces to one another.

3. Electrical contact according to claim 2, wherein said second piece is formed from a blank (109) which is
35 stamped and rolled.

4. Electrical contact according to claim 2 or 3, wherein the first piece comprises a ring (16) defining an aperture through which the second piece (33) is inserted.

5. Electrical contact according to any preceding claim, wherein the receiving space (15) is adapted for receiving an electrical wire extending along a first longitudinal direction (X),

wherein the power contact portion (33) extends around a second longitudinal direction (Y) for receiving the complementary contact,

wherein the first (X) and second (Y) longitudinal directions are orthogonal.

6. An electrical contact comprising :

- a first electrically conductive piece (10), comprising a wire crimping portion (11) comprising a receiving space (15) adapted for receiving an electrical wire extending along a first longitudinal direction (X), and at least one wing (14) adapted to be crimped on an electrical wire received in the receiving space,

- a second distinct electrically conductive piece formed from a blank (109) which is stamped and rolled, mechanically retained on the first piece (10) and comprising a circumferential power contact portion (33) electrically connected to the wire crimping portion (11), extending around a second longitudinal direction (Y) for receiving the complementary contact and defining a connecting space (61) for connection with a complementary contact,

wherein the first and second longitudinal directions are orthogonal,

said power contact portion (33) comprising :

- a body (34) mechanically retained on the wire crimping portion, and

- a plurality of spring legs (35), each extending from the body, to be contacted with the complementary

contact,

the electrical contact further comprising an electrically insulating cover (20) mechanically retained on one portion chosen among the wire crimping portion (11) and
5 the power contact portion (33), and covering said spring legs (35).

7. Electrical contact according to any preceding claim, wherein the cover comprises:

- a connecting portion (21) adapted to engage
10 with said one portion chosen among the wire crimping portion and the power contact portion to lock the cover onto said portion,

- a protecting portion (22) comprising a body (23) having an inner cylindrical wall (23b) defining an
15 inside space (25),

wherein said spring legs (35) are inside said inside space (25).

8. Electrical contact according to claim 7, wherein the inner cylindrical wall (23b) extends from a first end
20 connected to the connecting portion (21) to an opposite second end connected to a radially inward extending collar (24).

9. Electrical contact according to any preceding claim, wherein said cover comprises a locking feature (30)
25 adapted to engage with a complementary locking feature of an electrically insulative housing, for mechanical retention of the electrical contact in said housing.

10. Electrical contact according to any preceding claim, wherein said cover comprises a fool-proofing feature
30 (32) adapted to engage with a complementary fool-proofing body for a first pathway of an electrically insulative housing for allowing an insertion of said contact (38) in said first pathway, and to engage with a complementary fool-proofing body for a second pathway of the electrically
35 insulative housing for preventing an insertion of said

contact in said second pathway.

11. An electrical contact comprising:

- a wire crimping portion (11) comprising a receiving space (15) adapted for receiving an electrical wire, and at least one wing (14) adapted to be crimped on an electrical wire received in the receiving space,

- a circumferential power contact portion (33) electrically connected with the wire crimping portion (11), and defining a connecting space (61) for connection with a complementary contact,

said power contact portion (33) comprising:

- a body (34) mechanically retained on the wire crimping portion, and

- a plurality of spring legs (35), each extending from the body, to be contacted with the complementary contact,

the electrical contact further comprising an electrically insulating cover (20) mechanically retained on one portion chosen among the wire crimping portion (11) and the power contact portion (33), and covering said spring legs (35),

wherein said cover comprises a locking feature (30) adapted to engage with a complementary locking feature of an electrically insulative housing, for mechanical retention of the electrical contact in said housing,

wherein said cover comprises a fool-proofing feature (32) adapted to engage with a complementary fool-proofing body for a first pathway of an electrically insulative housing for allowing an insertion of said contact (38) in said first pathway, and to engage with a complementary fool-proofing body for a second pathway of the electrically insulative housing for preventing an insertion of said contact in said second pathway.

12. Electrical contact according to any preceding claim, wherein the cover (20) does not cover the wing (14).

13.A product comprising a connection strip (7), and a plurality of electrical contacts (38) each according to any of the preceding claims and mechanically connected to the connection strip.

5 14.A set of contacts comprising :

- at least a first contact (38a) according to claim 10 or 11, adapted to be inserted in a first pathway (41a) of an electrically insulative housing, and prevented to be inserted in a second pathway (41b, 41c) of the electrically insulative housing,

- at least a second contact (38b) according to claim 10 or 11, adapted to be inserted in the second pathway (41b), and prevented to be inserted in the first pathway (41a),

15 the fool-proofing features (32) of the first and second contacts being of different geometry.

15.A set of contacts according to claim 14, wherein the cover (20a) of the first contact (38a) comprises a first pigment providing a first colour to the cover, wherein the cover (20b) of the second contact (38b) comprises a second pigment providing a second colour to the cover, different from the first colour.

16.An assembly comprising:

- an electrically insulating housing (40) comprising a plurality of pathways (41a, 41b,41c),

- a plurality of electrical contacts (38a, 38b, 38c) each according to any of claims 1 to 12, or a set of contacts according to claim 14 or 15, each electrical contact being adapted to be inserted in a respective pathway of the housing,

- a plurality of electrical wires (42), each corresponding to a respective electrical contact.

17.An assembly comprising:

- an electrically insulating housing (40) comprising a plurality of pathways (41a, 41b,41c),

- a plurality of electrical wires (42),
- a plurality of electrical contacts (38a, 38b, 38c), each corresponding to a respective wire, and each comprising :

5 · a wire crimping portion (11) comprising a receiving space (15) adapted for receiving an electrical wire, and at least one wing (14) crimped on the electrical wire received in the receiving space,

 · a circumferential power contact portion (33) electrically connected to the wire crimping portion (11),
10 and defining a connecting space (61) for connection with a complementary contact,

- said power contact portion (33) comprising:

 · a body (34) mechanically retained on the wire
15 crimping portion, and

- a plurality of spring legs (35), each extending from the body, to be contacted with the complementary contact,

 the electrical contact further comprising an
20 electrically insulating cover (20) mechanically retained on one portion chosen among the wire crimping portion (11) and the power contact portion (33), and covering said spring legs (35), and not covering the crimped wing (14), each electrical contact being adapted to be inserted in a
25 respective pathway of the housing.

18. An assembly according to claim 16 to 17, further comprising a complementary connector (139) adapted to be mated with the housing (40), said complementary connector comprising a plurality of mating electrical contacts (51)
30 each adapted to be placed in contact with the spring legs (35) of a respective electrical contact (28) held in the housing,

 wherein the complementary connector comprises a plurality of electrically insulating cylindrical
35 passageways (50) each surrounding a respective mating

electrical contact (51), and adapted to engage with the respective cover (20) by complementarity of shapes.

19. Method of manufacture of an electrical contact comprising:

5 - forming a wire crimping portion (11) comprising a receiving space (15) adapted for receiving an electrical wire, and at least one wing (14) adapted to be crimped on an electrical wire received in the receiving space,

 - forming a circumferential power contact portion
10 (33) defining a connecting space (61) for connection with a complementary contact,

 said power contact portion being formed with:

 - a body (34), and
 - a plurality of spring legs (35), each extending
15 from the body, to be contacted with the complementary contact,

the power contact portion being electrically connected to the wire crimping portion (11), by mechanical retention of the body (34) on the wire crimping portion, and

20 - fixing an electrically insulating cover (20) covering said spring legs (25), and not covering the wing (14), on one portion chosen among the wire crimping portion and the power contact portion.

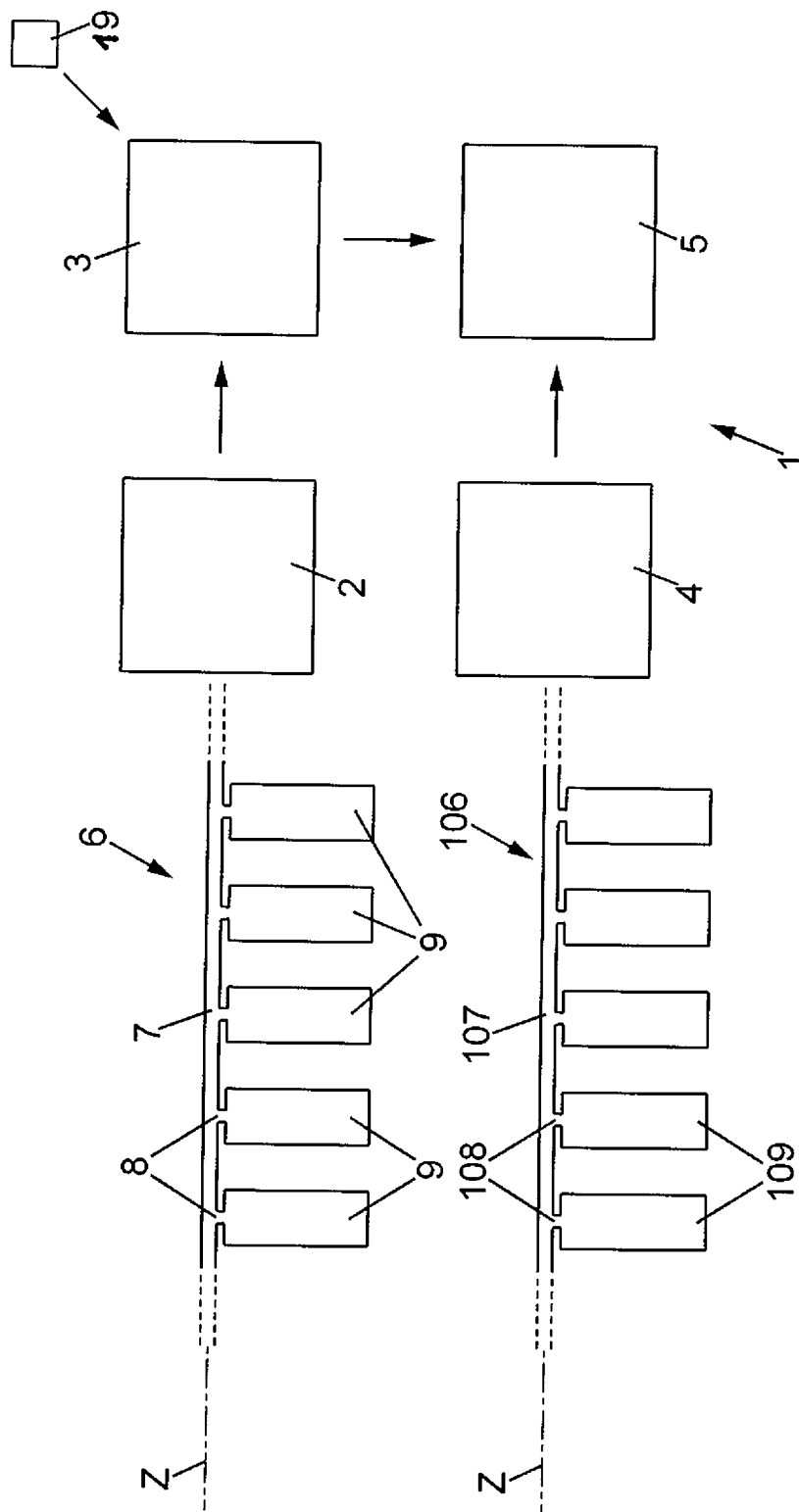
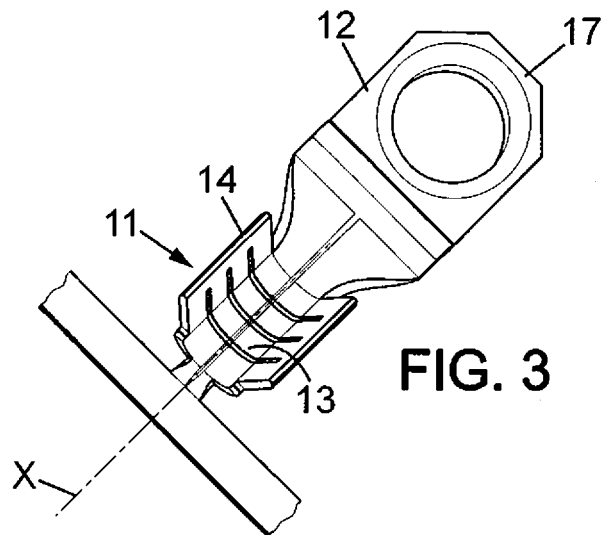
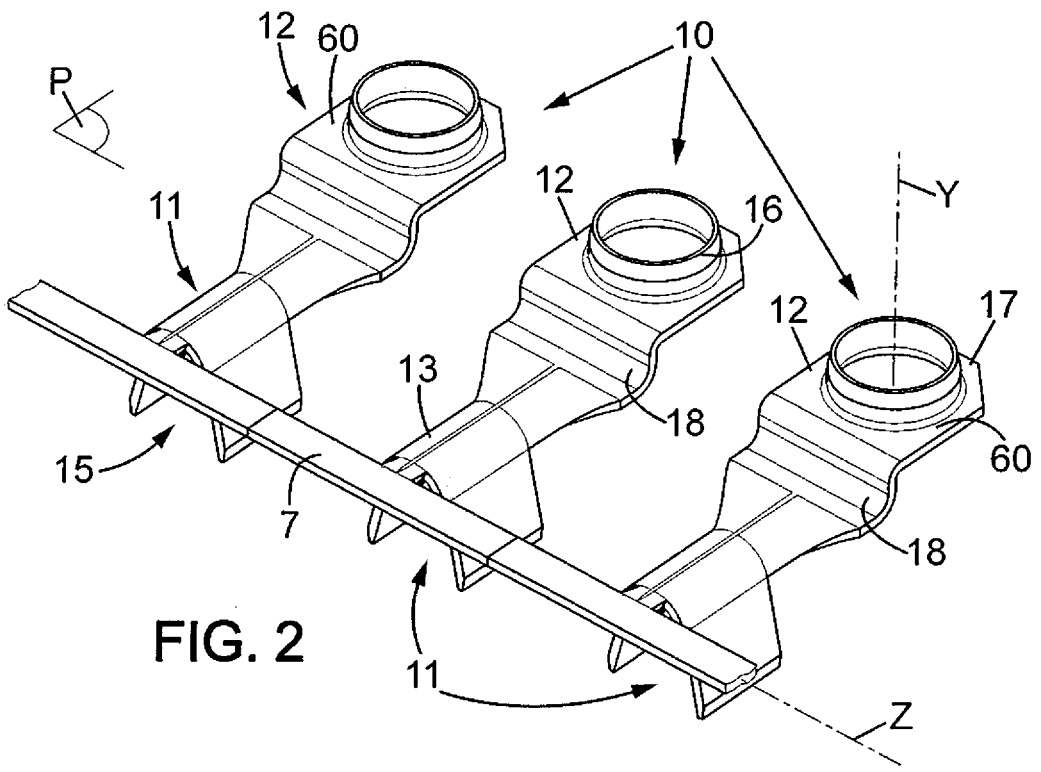
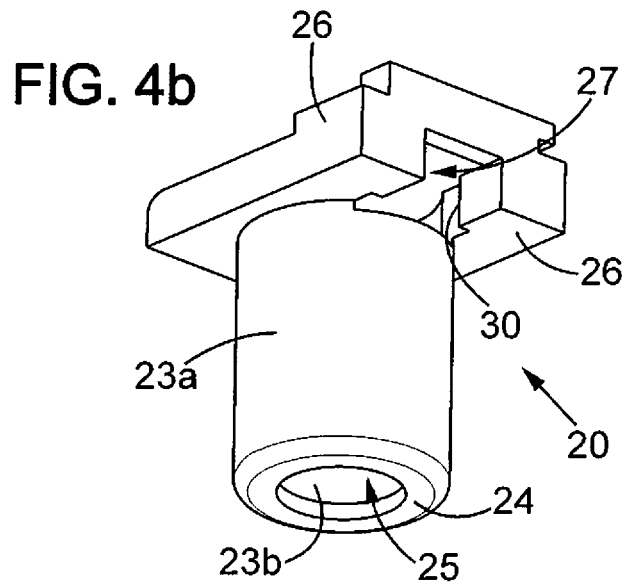
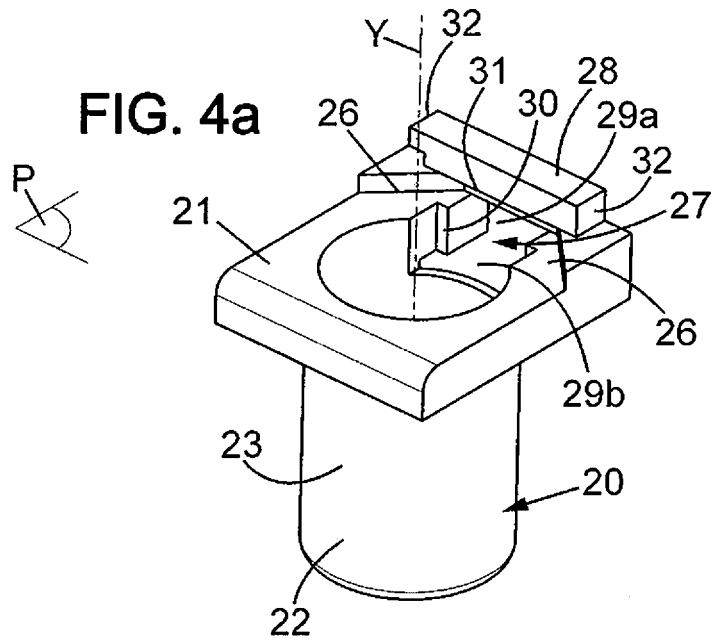

FIG. 1





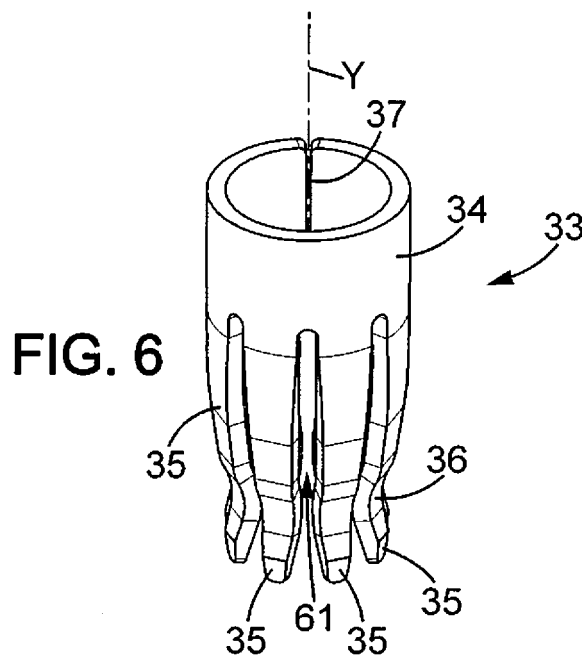
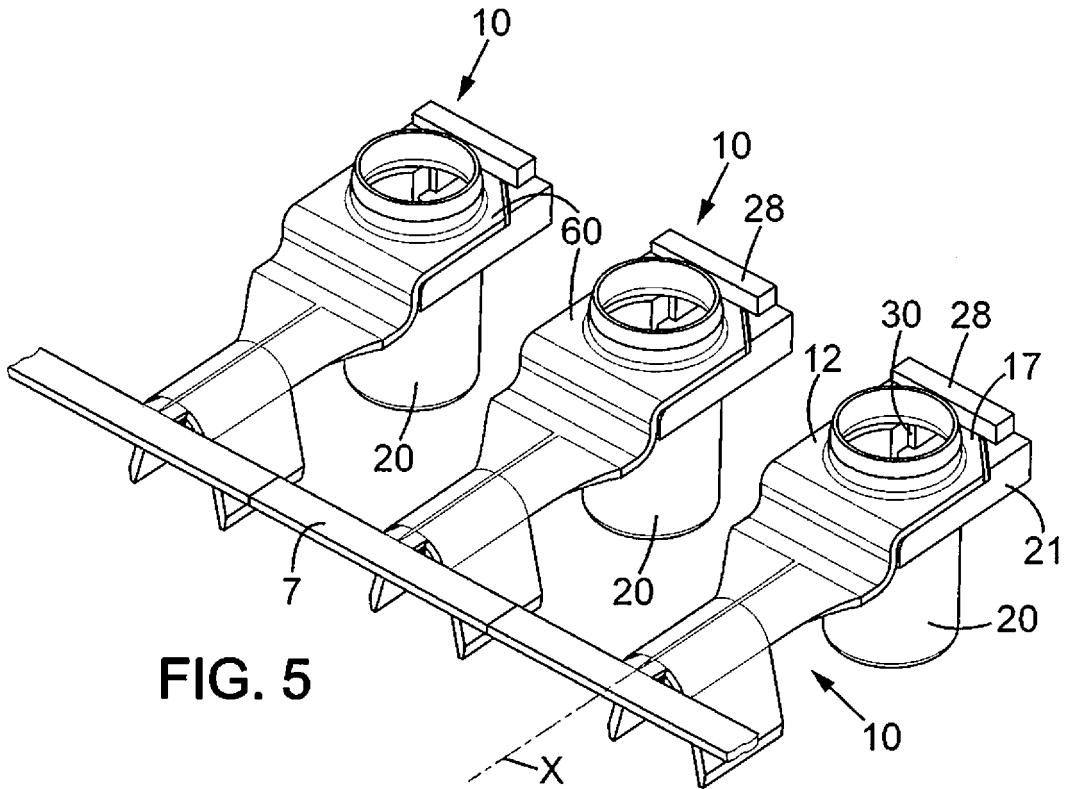

FIG. 7

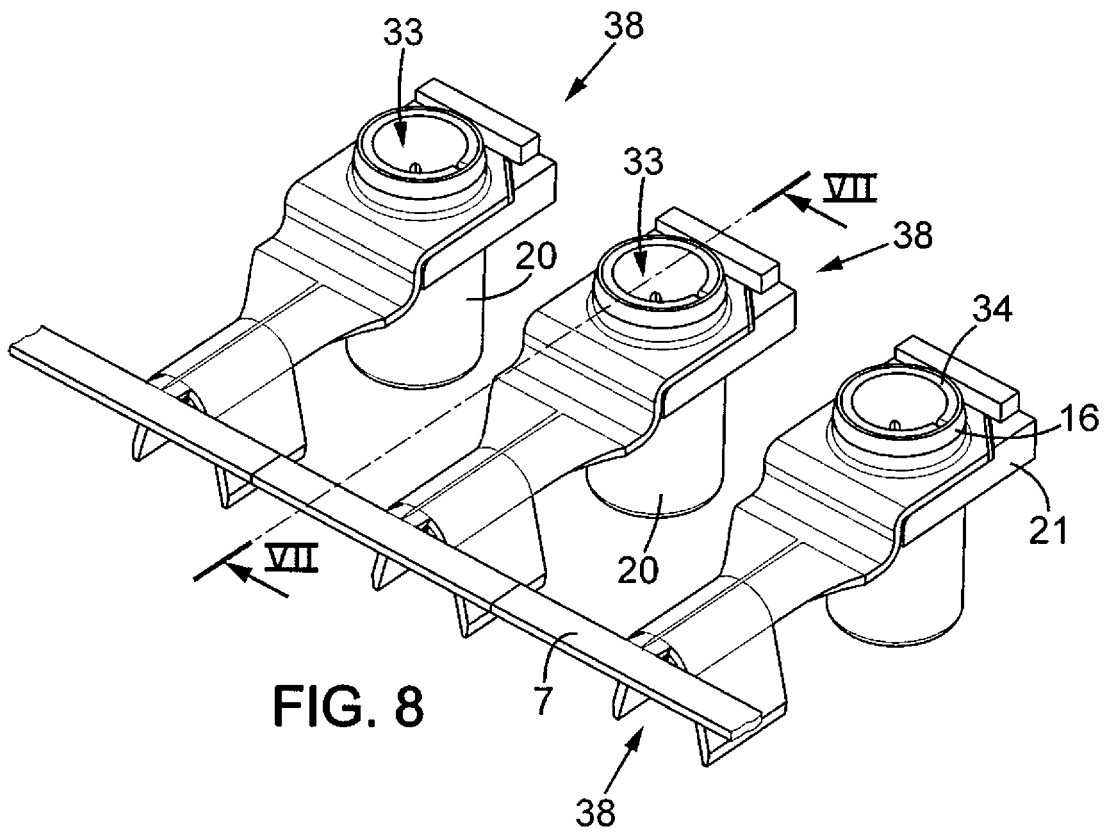
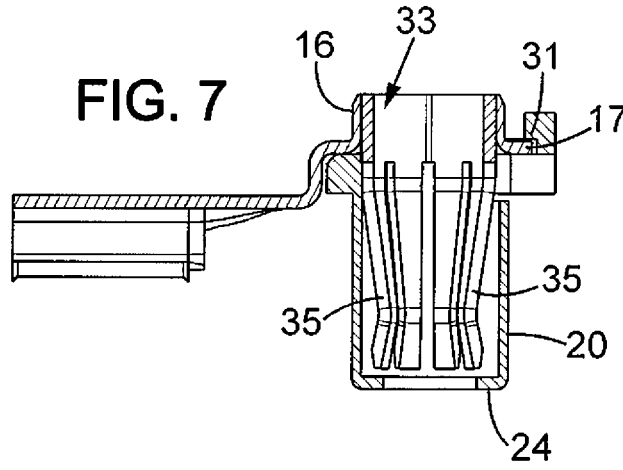

FIG. 8

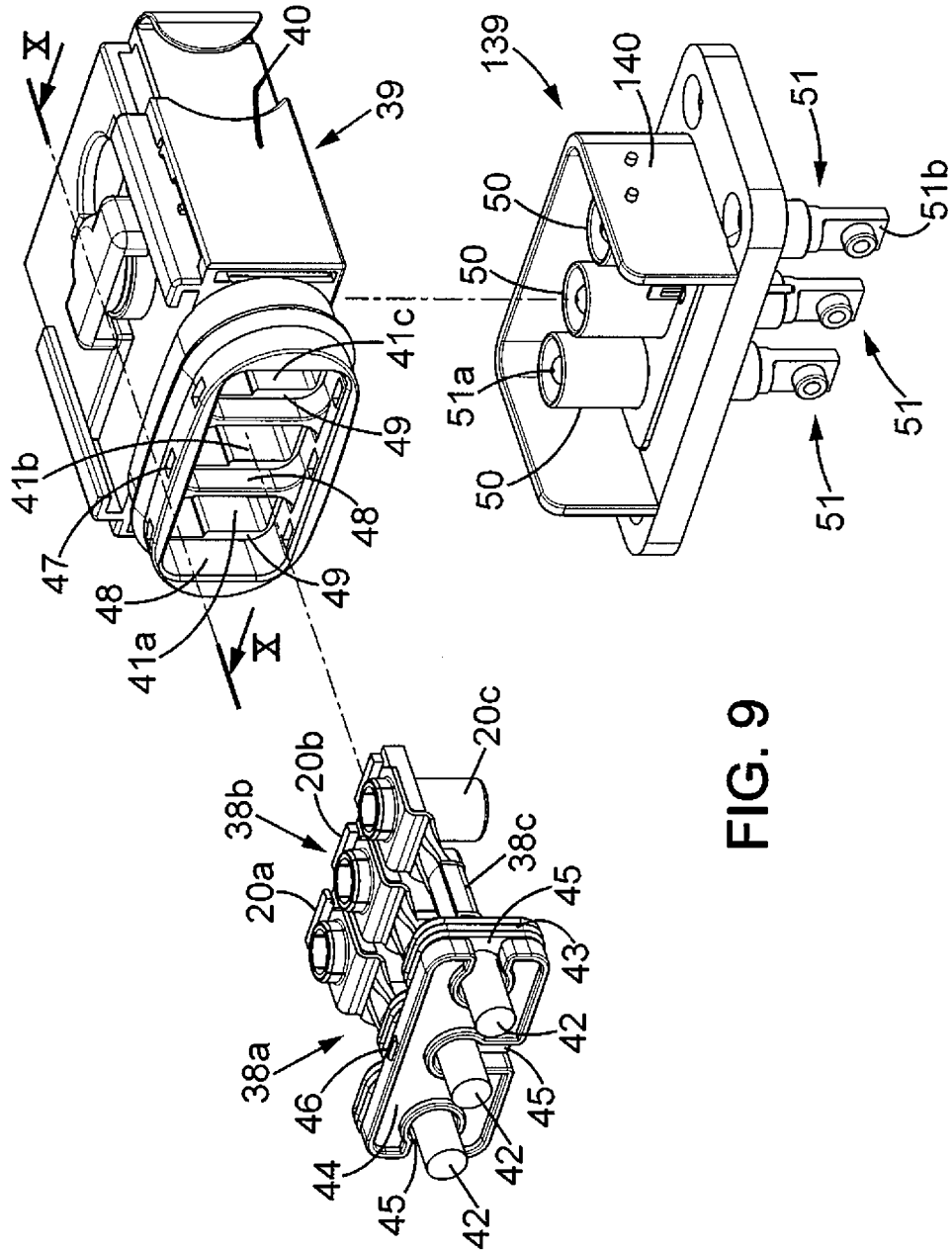

FIG. 9

7/8

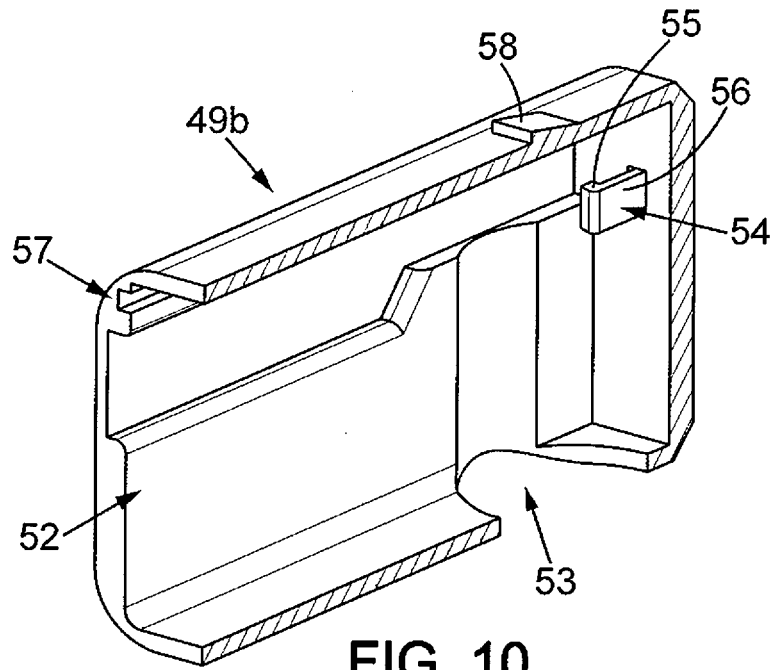

FIG. 10

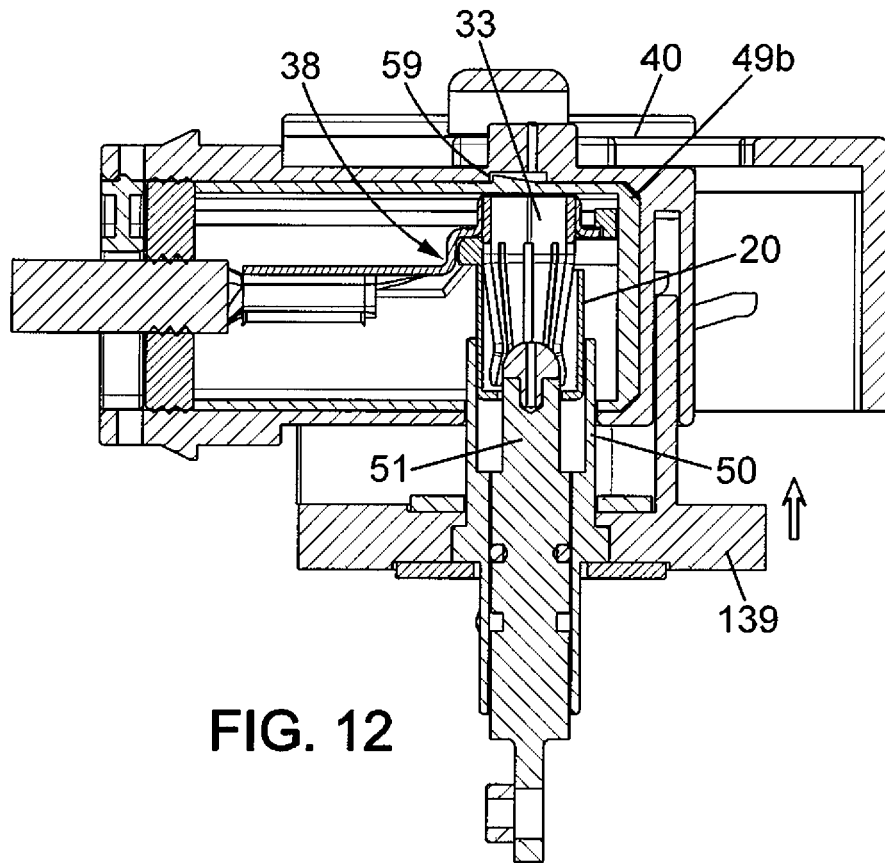

FIG. 12

8/8

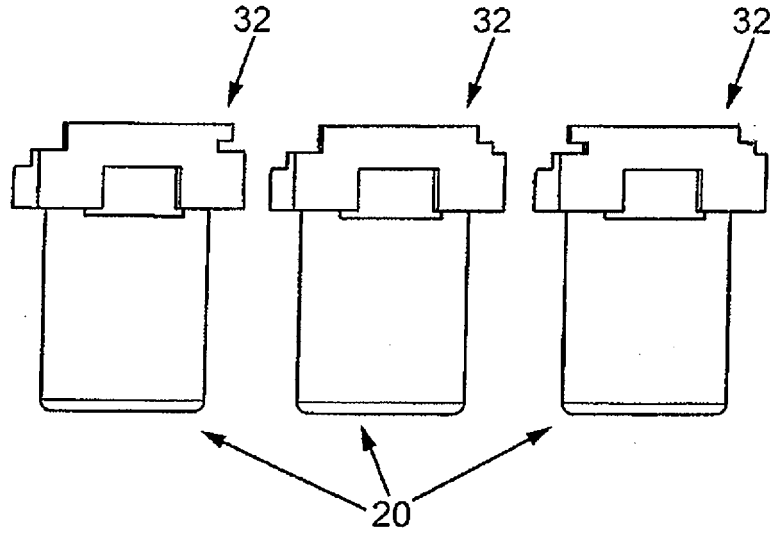

FIG. 11a

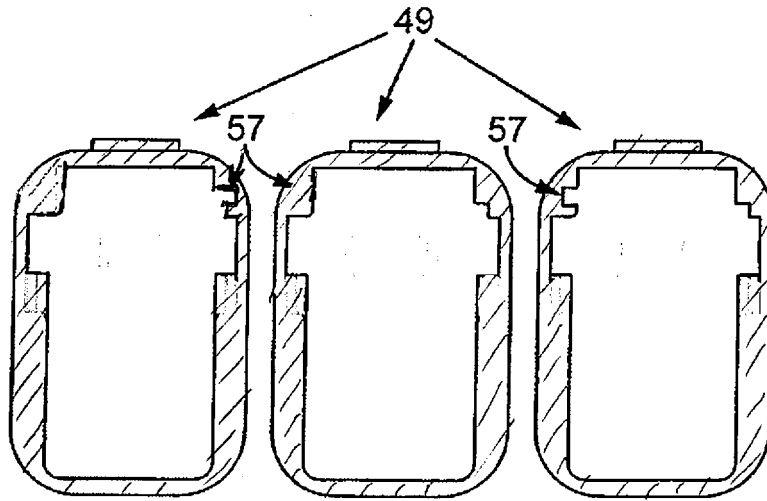

FIG. 11b

INTERNATIONAL SEARCH REPORT

International application No
PCT/IB2008/055608

A. CLASSIFICATION OF SUBJECT MATTER INV. HO1R13/187		
According to International Patent Classification (IPC) or to both national classification and IPC		
B. FIELDS SEARCHED		
Minimum documentation searched (classification system followed by classification symbols) HO1R		
Documentation searched other than minimum documentation to the extent that such documents are included in the fields searched		
Electronic data base consulted during the international search (name of data base and, where practical, search terms used) EPO-Internal		
C. DOCUMENTS CONSIDERED TO BE RELEVANT		
Category*	Citation of document, with indication, where appropriate, of the relevant passages	Relevant to claim No.
X	US 5 667 413 A (TRAFTON MICHAEL L [US]) 16 September 1997 (1997-09-16) column 2 - column 5; figure 5 -----	1-12, 14-19
X	EP 0 767 514 A (ITT MFG ENTERPRISES INC [US]) 9 April 1997 (1997-04-09) figure 1 -----	1
A	EP 1 041 675 A (FCI KATRINEHOLM A B [SE]) 4 October 2000 (2000-10-04) figure 3 -----	1
X	DE 20 2006 008718 U1 (RAUSCHERT ESPANA S L [ES]) 4 October 2007 (2007-10-04) figure 1 -----	1,13
<input type="checkbox"/> Further documents are listed in the continuation of Box C. <input checked="" type="checkbox"/> See patent family annex.		
* Special categories of cited documents :		
A document defining the general state of the art which is not considered to be of particular relevance *E* earlier document but published on or after the international filing date *L* document which may throw doubts on priority claim(s) or which is cited to establish the publication date of another citation or other special reason (as specified) *O* document referring to an oral disclosure, use, exhibition or other means *P* document published prior to the international filing date but later than the priority date claimed	*T* later document published after the international filing date or priority date and not in conflict with the application but cited to understand the principle or theory underlying the invention *X* document of particular relevance; the claimed invention cannot be considered novel or cannot be considered to involve an inventive step when the document is taken alone *Y* document of particular relevance; the claimed invention cannot be considered to involve an inventive step when the document is combined with one or more other such documents, such combination being obvious to a person skilled in the art. *&* document member of the same patent family	
Date of the actual completion of the international search <p style="text-align: center; font-weight: bold;">19 June 2009</p>	Date of mailing of the international search report <p style="text-align: center; font-weight: bold;">26/06/2009</p>	
Name and mailing address of the ISA/ European Patent Office, P.B. 5818 Patentlaan 2 NL - 2280 HV Rijswijk Tel. (+31-70) 340-2040, Fax: (+31-70) 340-3016	Authorized officer <p style="text-align: center; font-weight: bold;">Langbroek, Arjen</p>	

INTERNATIONAL SEARCH REPORT

Information on patent family members

International application No

PCT/IB2008/055608

Patent document cited in search report	A	Publication date	Patent family member(s)	Publication date
US 5667413	A	16-09-1997	NONE	
EP 0767514	A	09-04-1997	DE 69603812 D1 DE 69603812 T2 US 5658175 A	23-09-1999 16-03-2000 19-08-1997
EP 1041675	A	04-10-2000	DE 60014999 D1 DE 60014999 T2 SE 517582 C2 SE 9901181 A US 6186841 B1	25-11-2004 03-11-2005 25-06-2002 31-10-2000 13-02-2001
DE 202006008718 U1		04-10-2007	NONE	