

(19) World Intellectual Property Organization
International Bureau



(43) International Publication Date
17 February 2005 (17.02.2005)

PCT

(10) International Publication Number
WO 2005/014187 A2

- (51) International Patent Classification⁷: B07B 1/46, B01D 33/00
 - (21) International Application Number: PCT/GB2004/002914
 - (22) International Filing Date: 6 July 2004 (06.07.2004)
 - (25) Filing Language: English
 - (26) Publication Language: English
 - (30) Priority Data: 10/627,190 25 July 2003 (25.07.2003) US
 - (71) Applicants (for all designated States except US): VARCO I/P, INC. [US/US]; One BriarLake Plaza, 2000 West Sam Houston Parkway South, Suite 1700, Houston, Texas 77042 (US). LUCAS, Brian, Ronald [GB/GB]; Lucas & Co., 135 Westhall Road, Warlingham Surrey CR6 9HJ (GB).
 - (72) Inventors; and
 - (75) Inventors/Applicants (for US only): ADAMS, Thomas, Cole [US/US]; 27306 Teepee Trail, Hockley, Texas 77447 (US). WARD, Kerry [US/US]; 13527 Post Oak Glen Lane, Cypress, Texas 77429 (US). CLARK, Larry, Keith.
 - (74) Agent: LUCAS, Brian, Ronald; 135 Westhall Road, Warlingham, Surrey CR6 9HJ (GB).
 - (81) Designated States (unless otherwise indicated, for every kind of national protection available): AE, AG, AL, AM, AT, AU, AZ, BA, BB, BG, BR, BW, BY, BZ, CA, CH, CN, CO, CR, CU, CZ, DE, DK, DM, DZ, EC, EE, EG, ES, FI, GB, GD, GE, GH, GM, HR, HU, ID, IL, IN, IS, JP, KE, KG, KP, KR, KZ, LC, LK, LR, LS, LT, LU, LV, MA, MD, MG, MK, MN, MW, MX, MZ, NA, NI, NO, NZ, OM, PG, PH, PL, PT, RO, RU, SC, SD, SE, SG, SK, SL, SY, TJ, TM, TN, TR, TT, TZ, UA, UG, US, UZ, VC, VN, YU, ZA, ZM, ZW.
 - (84) Designated States (unless otherwise indicated, for every kind of regional protection available): ARIPO (BW, GH, GM, KE, LS, MW, MZ, NA, SD, SL, SZ, TZ, UG, ZM, ZW), Eurasian (AM, AZ, BY, KG, KZ, MD, RU, TJ, TM), European (AT, BE, BG, CH, CY, CZ, DE, DK, EE, ES, FI, FR, GB, GR, HU, IE, IT, LU, MC, NL, PL, PT, RO, SE, SI, SK, TR), OAPI (BF, BJ, CF, CG, CI, CM, GA, GN, GQ, GW, ML, MR, NE, SN, TD, TG).
- Published: — without international search report and to be republished upon receipt of that report

[Continued on next page]

(54) Title: APPARATUS AND METHOD FOR MAKING SCREEN ASSEMBLIES FOR VIBRATORY SEPARATORS

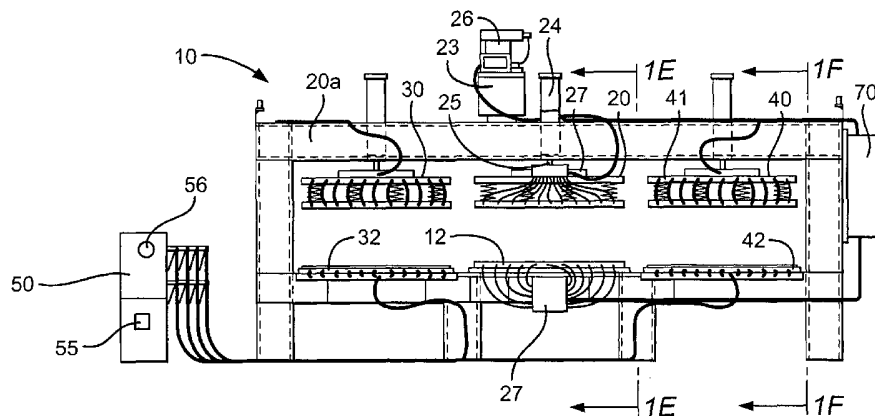

(57) Abstract: An apparatus for use in the making of a screen assembly, the apparatus comprising a platen (31, 41, 32, 42) and a heat exchanger (62, 67) for removing heat from said platen. The invention also relates to an apparatus for use in the making of a screen assembly, the apparatus comprising a platen (21, 22) and a plurality of elements (22h) through which electric current flows for heating said platen (21, 22) characterised in that said platen (21, 22) further comprises at least one sensor (27a-f) for measuring the temperature of said platen (21, 22). The invention also relates to an apparatus for use in the making of a screen assembly, the apparatus comprising a platen (21, 22) having zones and a plurality of elements (22h) through which electric current flows for heating said platen (21, 22) characterised in that said elements (22h) are independently controllable for independently controlling the temperature of said zones in said platen (21, 22). The invention also relates to a method for making a screen assembly, the method comprising the steps of placing a screen, a heat activated adhesive and a screen support in or on a heated apparatus to melt said heat activated adhesive, characterised in that the method further comprises the steps of placing the screen, heat activated adhesive and screen support combination on or in a cooling platen provided with a heat exchanger to facilitate maintenance of the temperature of the cooling platen for cooling said heat activated adhesive.

WO 2005/014187 A2



For two-letter codes and other abbreviations, refer to the "Guidance Notes on Codes and Abbreviations" appearing at the beginning of each regular issue of the PCT Gazette.

- 1 -

APPARATUS AND METHOD FOR MAKING SCREEN ASSEMBLIES
FOR VIBRATORY SEPARATORS

5 This invention relates to apparatus for making
screen assemblies for vibratory separators and methods
for making such screen assemblies.

10 In the drilling of a borehole in the construction of
an oil or gas well, a drill bit is arranged on the end of
a drill string and is rotated to bore the borehole. A
drilling fluid known as "drilling mud" is pumped through
the drill string to the drill bit to lubricate the drill
bit. The drilling mud is also used to carry the cuttings
produced by the drill bit and other solids to the surface
through an annulus formed between the drill string and
15 the borehole. The drilling mud contains expensive
synthetic oil-based lubricants and it is normal therefore
to recover and re-use the used drilling mud, but this
requires the solids to be removed from the drilling mud.
This is achieved by processing the drilling fluid. The
20 first part of the process is to separate the solids from
the solids laden drilling mud. This is at least partly
achieved with a vibratory separator, such as those shale
shakers disclosed in US 5,265,730, WO 96/33792 and WO
98/16328.

25 Shale shakers generally comprise an open bottomed
basket having one open discharge end and a solid walled
feed end. A number of rectangular screens are arranged in
the basket, which are held in C-channel rails located on
the basket walls, such as those disclosed in GB-A-
30 2,176,424. The basket is arranged on springs above a
receptor for receiving recovered drilling mud. A skip or
ditch is provided beneath the open discharge end of the
basket. A motor is fixed to the basket, which has a drive
rotor provided with an offset clump weight. In use, the

- 2 -

motor rotates the rotor and the offset clump weight, which causes the basket and the screens fixed thereto to shake. Solids laden mud is introduced at the feed end of the basket on to the screens. The shaking motion induces
5 the solids to move along the screens towards the open discharge end. Drilling mud passes through the screens. The recovered drilling mud is received in the receptor for further processing and the solids pass over the discharge end of the basket into the ditch or skip.

10 The screens are generally of one of two types: hook-strip; and pre-tensioned.

The hook-strip type of screen comprises several rectangular layers of mesh in a sandwich, usually comprising one or two layers of fine grade mesh and a
15 supporting mesh having larger mesh holes and heavier gauge wire. The layers of mesh are joined at each side edge by a strip which is in the form of an elongate hook. In use, the elongate hook is hooked on to a tensioning device arranged along each side of a shale shaker. The
20 shale shaker further comprises a crowned set of supporting members, which run along the length of the basket of the shaker, over which the layers of mesh are tensioned. An example of this type of screen is disclosed in GB-A-1,526,663. The supporting mesh may be provided
25 with or replaced by a panel having apertures therein.

The pre-tensioned type of screen comprises several rectangular layers of mesh, usually comprising one or two layers of fine grade mesh and a supporting mesh having larger mesh holes and heavier gauge wire. The layers of
30 mesh are pre-tensioned on a rigid support comprising a rectangular angle iron frame and adhered thereto. The screen is then inserted into C-channel rails arranged in a basket of a shale shaker. An example of this type of screen is disclosed in GB-A-1,578,948.

35 A further example of a known rigid support is

- 3 -

disclosed in PCT Publication No. WO 01/76719, which discloses, amongst other things, a flat panel like portion having apertures therein and wing portions which are folded to form a support structure, which may be made from a single sheet of material. This rigid support has been assigned the Trade Mark "UNIBODY" by the applicants.

The layers of mesh in the screens wears out frequently and therefore needs to be easily replaceable. Shale shakers are generally in the order of 5ft wide and 10ft long. A screen of dimensions 4ft wide by 10ft long is difficult to handle, replace and transport. It is known to use two, three, four or more screens in a single shale shaker. A standard size of screen currently used is of the order of 4ft by 3ft.

US-A-6,450,345 issued Sept. 17, 2002 and U.S. Applications Nos. 10/037,474; 10/087,025; and 10/210,891 [all said patent and said applications incorporated fully herein for all purposes] disclose, *inter alia*, methods for making glued screen assemblies for vibratory separators and screen assemblies made by such methods. In certain aspects the glue used is hot melt glue which is allowed to cool at room temperature to complete the process of screen assembly manufacture. In many instances it takes up to twenty minutes for the glue in a screen assembly to cool so that the screen assembly can then be stored or packaged and shipped.

WO 03/033102 discloses a method for making a screen, the method comprising the steps of unrolling a first layer of screening material from a first roll and applying glue to said first layer of screening material, and unrolling at least a second layer of screening material and applying the second layer of screening material to the first layer of screening material with an

- 4 -

apparatus characterised in that the apparatus is heated. Preferably, the apparatus comprises a top member arranged above the first and second layer of screening material and a bottom member arranged under the first and second layer of screening material, the method further comprising the step of heating the top member. Advantageously, the top member is a roller forming a nip with the bottom member. Preferably, the roller comprises a reservoir for a hot fluid. Advantageously, the bottom member is cooled. Preferably, the bottom member is a roller forming a nip with the top member.

WO 03/033102 also discloses a method for making a screen, the method comprising the steps of unrolling a first layer of screening material from a first roll and applying glue to said first layer of screening material, and unrolling at least a second layer of screening material and applying the second layer of screening material to the first layer of screening material to form a screen, characterised in that said screen has a coolant applied thereto. Preferably, the coolant is water. Advantageously, the coolant is sprayed on to said screen. Preferably, the coolant is applied to the top of the screen. Advantageously, the coolant is applied to the side of the screen to which the at least second layer of screening material was applied. Preferably, the screen is rolled on to a rewind apparatus to form a roll. Advantageously, the roller comprises a reservoir for a cold fluid.

Once the screen is made, having been made by either of the methods disclosed in WO 03/033102, a frame and the screen are placed on a heated platen. The currently semi-cured powdered epoxy is heated to a flowable state

- 5 -

(e.g. to 140°C (300°F) to 260°C (500°F)). The screen material area adjacent to the frame is thus encapsulated in the powdered epoxy. After about 5 to 10 minutes of heat and pressure (e.g. about 155 Bars (2250psi) to 27.6
5 Bars (400psi) the screen and frame are removed and allowed to cool down to ambient room temperature. The cured powdered epoxy encapsulates the screen material, adjacent to the frame and the frame forming a unitary structure. Coating thickness to achieve good
10 encapsulation, in certain aspects, is between 20 and 40 mils.

In certain particular known methods for making a glued screen assembly two or more layers of screening material are placed on a heated platen apparatus. One or
15 more layers have an amount of hot melt glue thereon and heating and compressing the layers together with the apparatus glues them together with heat from the heated platen apparatus heating the glue.

There has been a need, recognized by the present
20 inventors, for facilitating the cooling of glued screen assemblies. There has been a need, recognized by the present inventors, to reduce the time needed to process a glued screen assembly for packaging and shipment. There has been a need, recognized by the present inventors, for
25 a method for uniformly heating screen assembly components used to make a screen assembly.

According to the present invention, there is provided an apparatus for use in the making of a screen assembly, the apparatus comprising a platen and a heat
30 exchanger for removing heat from the platen. The platen is a preferably a flat plate of metal and has a substantially planar surface, approximately the same or

- 6 -

slightly larger than the size of a screen.

Preferably, the heat exchanger comprises at least one channel through which a coolant can flow. Advantageously, the heat exchanger comprises a
5 multiplicity of channels through which a coolant can flow. The multiplicity of channels may diverge from a manifold out into the heat exchanger and may converge in manifold from and to a single source of coolant. Advantageously, the coolant is a liquid. The apparatus
10 may comprise a pump for pumping the coolant and the system may circulate the same coolant in a sealed system continuously or intermittently. A cooling apparatus may be used, which may comprise a fan, a further heat exchanger, chiller, radiator or cooled by natural ambient
15 temperature.

Advantageously, the apparatus comprises a further platen, the platen and the further platen having surfaces which oppose one another between which a screen is arrangeable. Preferably, the further platen comprises a
20 heat exchanger for roving heat therefrom. Advantageously, the further platen is moveable in relation to the platen preferably, on a piston and cylinder to allow the screen, adhesive and support to be placed on the platen and for the further platen to be moved by the piston and
25 cylinder, which may be pneumatic or hydraulic to apply engage and/or apply pressure on the screen, adhesive screen support. The movable platen may provide a compressing force on the screen, heat activated adhesive and screen support so that the heat activated adhesive
30 flows into one, two, three or more of the layers of screening material which may form the screen.

Preferably, the platen and/or the further platen is

- 7 -

arranged on springs, such that the springs push on a screen in use, in one aspect, to facilitate even pressure across the screen.

5 The present invention also provides an arrangement for use in the making of a screen assembly, the arrangement comprising the apparatus of the present invention, the arrangement further comprising a heating apparatus for heating heat activated adhesive in a screen and screen support combination.

10 Preferably, the arrangement further comprises a further cooling apparatus of the invention. Multiple cooling apparatuses are used adjacent and spaced-apart from a heated platen apparatus so that as a hot glued-together screen assembly or screen combination is
15 available from the heated platen apparatus, it can be removed therefrom and placed on a cooling apparatus. For example, in certain aspects it takes three to four minutes to process a glued-together screen assembly in the heated platen apparatus, but one-and-a-half to two
20 minutes to cool the heated glue; and two cooling apparatuses are used in conjunction with the single heated platen apparatus so that each glued-together screen assembly can be quickly removed from the heated platen apparatus and processed by an available cooling
25 apparatus.

Preferably, the heating apparatus and cooling apparatus(es) of the invention are mounted in a frame.

The present invention also provides a method for making a screen assembly, the method comprising the steps
30 of placing a screen, a heat activated adhesive and a screen support in or on a heated apparatus to melt the heat activated adhesive, characterised in that the method

- 8 -

further comprises the steps of placing the screen, heat activated adhesive and screen support combination on or in a cooling platen provided with a heat exchanger to facilitate maintenance of the temperature of the cooling platen for cooling the heat activated adhesive.

In one embodiment, the screen may be placed in first, heated, then adhesive and screen support placed on top of the preheated screen.

Preferably, the screen comprises at least one layer of fine screening material. Advantageously, the screen is made up of at least two layers of screening material. The at least two layers of screening material may be glued together using the method described in WO 01/39861, the disclosure of which is incorporated herein for all purposes and co-owned by the applicant for the present application.

Preferably, the heated apparatus comprises a heated platen. Advantageously, the screen support comprises a frame. The frame may comprise an array of tubular members. The frame may be coated with heat activated adhesive material for adhering the frame to the screen. The frame preferably inhibits the screen from rippling, or rolling up and advantageously prevents the screen from bowing and most preferably holds tension in the screen.

Preferably, the screen support comprises a coarse layer of supporting mesh. Alternatively or additionally, the screen support comprises a perforated plate.

Preferably, the cool platen is maintained at substantially room temperature. Or may be at or close to the coolant temperature.

Advantageously, the at least one layer of screening material is a layer of coarse mesh.

- 9 -

Preferably, the heat activated glue is applied in a pattern on the at least one layer of screening material and is cured glue prior to placing the at least one layer of screening material on the heating apparatus.
5 Advantageously, the heat activated adhesive is moisture-curing hot melt glue. Advantageously, the at least one layer of screening material is heated sufficiently to soften the heat activated glue.

Preferably, the screen support is heated
10 sufficiently so that at least some of the adhesive material flows onto the screen to adhere together the screen support and the screen. Advantageously, the heat activated adhesive material is powderized epoxy material.

Advantageously, the method further comprises the
15 steps of placing a second screen, heat activated adhesive and screen support combination in the heating apparatus, and heating the heat activated adhesive and placing the screen, heat activated adhesive and screen support combination on or in a second cooling platen provided
20 with a heat exchanger to facilitate maintenance of the temperature of the cooling platen for cooling the heat activated adhesive. Preferably, the method further comprises the steps of placing a third screen, heat activated adhesive and screen support combination in the
25 heating apparatus, and heating the heat activated adhesive.

* * *

The present invention also provides an apparatus for use in the making of a screen assembly, the apparatus
30 comprising a platen and a plurality of elements through which electric current flows for heating the platen characterised in that the platen further comprises at

- 10 -

least one sensor for measuring the temperature of the platen.

Preferably, the apparatus further comprises at least one further sensor each sensor for measuring the temperature of a portion of the platen. Advantageously, the platen comprises a plurality of sensors, each for measuring the temperature of a portion, zone or area of the platen. This enables a temperature reading to be obtained for each section of the platen, each element independently activatable and controllable so that different zones, areas or portions of the screen and screen support combination can be heated differently. Temperature sensors measure the temperature for each zone or area so that an operator or an automatic controller can adjust the heat supplied to each zone or area. For example, outer edges of a screen combination often tend to lose heat faster than inner portions thereof and a heated platen apparatus as described above can be used to supply additional heat to these outer edges so that the entire screen combination is heated (and cools, using the apparatus of the first aspect of the invention) uniformly.

Preferably, the apparatus includes means for individually controlling the heat generated by each element, such as an electronic control circuit, resistive control etc.. Advantageously, the apparatus further comprises a feed back control circuit for analysing the data received from the sensors and controlling the heat given off by the elements, for example by controlling the flow of current to each element individually or in groups of two, three or more elements. This enables the heat applied to a the screen and screen and screen support

- 11 -

combination to be applied uniformly to the areas in which heat is needed. This is particularly important when using a screen support which has many openings therein, where conductance heat in air is low and areas of conductive metal where conductance of heat is high and forms the bonding surface. Thus this enables heat to be applied evenly to the areas in which the heat activated adhesive is located with precision and thus the resultant screen assembly will be of much more consistent and of a higher quality.

Thus, zone-controlled heating apparatus is provided for facilitating the application of a suitable uniform and/or effective amount of heat to each and every area of a screen combination or screen assembly to be heated and/or for facilitating uniform cooling thereof.

The present invention also provides an apparatus for use in the making of a screen assembly, the apparatus comprising a platen having zones and a plurality of elements through which electric current flows for heating the platen characterised in that the elements are independently controllable for independently controlling the temperature of the zones in the plate.

For a better understanding of the present invention, reference will now be made, by way of example, to the accompanying drawings in which:

Figure 1A is a top view of an apparatus in
5 accordance with the present invention;

Figure 1B is a side view of the apparatus shown in Figure 1A in a first stage of operation;

Figure 1C is a side view of the apparatus shown in Figure 1A in a second stage of operation;

10 Figure 1D is an end view of the apparatus shown in Figure 1A;

Figure 1E is a cross-section view along line 1E-1E of Figure 1B;

15 Figure 1F is a cross-section view along line 1F-1F of Figure 1B;

Figures 2A and 2B are schematic views of preferred parts of the apparatus in accordance with the present invention;

20 Figure 3 is a schematic representation of a fluid circulation system for use in an apparatus in accordance with the present invention;

Figure 4A is a view of a first side of an apparatus in accordance with the present invention, similar to that shown in Figure 1B, indicating an enlarged portion shown
25 in Figure 4C; and

Figure 4B is a view of a second side of an apparatus in accordance with the present invention, similar to the apparatus shown in Figure 1B, indicating an enlarged portion shown in Figure 4D.

30 Figures 1A to 1F show an apparatus 10 in accordance with the present invention. The apparatus 10 has a central heated platen apparatus 20 flanked on either side

- 13 -

by cooling apparatuses 30 and 40. A top platen 21 of the heated platen apparatus 20 is movable downwardly to compress together layers of screening material and a screen support combination 12 (shown schematically) on a base platen 22 so that hot melt glue in or on at least one of the layers is heated and flows to adjacent layer(s) to glue together the layers of screening material to the screen support (or, in other aspects, a powder adhesive coated frame is placed over one or more layers of screening material) and in a further aspect a perforated plate, which may also be powder coated.

The movable top platen 21 is connected to a movement apparatus 23 which has a piston and cylinder assembly 24 with a movable piston 25 to which the top platen 21 is connected. Hydraulic pump apparatus 26 connected to a support 20a selectively provides hydraulic fluid under pressure to the piston assembly 24 to move the top platen 21. As shown in Figure 1C the top platen 21 has been moved downwardly to cover the screen material layers 12 within the heated platen apparatus.

Electrical heating system 27 with heating elements (e.g. rods or wires) 21h in the top platen and 22h in the base platen are interconnected via a series of wires 28a, 28b. The elements 21h and 22h heat the top platen 21 and the base 22. In one particular aspect, the top platen is heated to above 204 Celsius (400 F) (in one aspect to about 232 Celsius (450 F)) and the base platen 22 is heated to about 38 Celsius (100 F) for heating the glue on the screening material layer(s) 12. In another aspect, both the top platen and the base are heated to above 204 Celsius (400 F) (in one aspect to about 232 Celsius (450 F)).

- 14 -

As shown in Figure 4C, the wires 28a and wires for the temperature sensors 27a-f for the base platen 22 lead to a box 70 enclosing parts of the lower heating apparatus 27 and the wires 28b and wires for the temperature sensors 27a-c for the top platen 21 lead to a junction box 29. A lower part 21a of the top platen 21 is, optionally, connected with a plurality of springs 21c to a top part 21b of the top platen 21. These springs 21c facilitate the application of uniform pressure onto items on the base platen 22. Similarly, optionally springs interconnect a top part to a bottom part of a top platen of the cooling apparatuses 30 and 40., as described below.

Upon raising the movable platen 21 the glued together layers and screen support combination 12 are removed from the base platen 22 and emplaced on a base platen 32 or 42 of the cooling apparatus 30 or 40. The base platens 32 and 42 are substantially flat planar surfaces which may be made of any suitable material which conducts heat well, such as steel, copper, brass, copper or steel alloys. A movable top platen 41 is moved down to cover the screening material layers 12. In one particular aspect the cooling apparatus 30, 40 [even in an environment with an ambient temperature above 32 Celsius (90 F)] cools - with the top platen 31, 41 and base platen 32, 42 at about 18 Celsius (65 F) - the heated screening material layers 12 to about 3 $\frac{1}{2}$ Celsius (88 F) in about 2 to 4 minutes.

Cooled fluid for cooling heated layers of screening material is provided continuously by a cooling system 50 which includes a cooling system 56 (for example, a chiller unit) and pumping apparatus 55. In one

- 15 -

particular aspect such a cooling system is a PCP 500 A model commercially available from Filtrins Mfg. Company. Cooled fluid (The cooling fluid may be cooled water or antifreeze) (shown schematically in Figure 3) is pumped
5 from the system 50 in a line 51, to lines 51A and 51B, and from them to the base platens 42 and 32, respectively, of the cooling apparatuses 40 and 30. Fluid (for example hotter water or antifreeze) exits the base 42 through a line 53B and the base 32 through line
10 53A which are in fluid communication with a return line 53 connected to and in fluid communication with the system 50. The returned fluid is re-cooled and then pumped back to the cooling apparatuses 30, 40 by the pump apparatus 55.

15 Cooled fluid is provided to the top platens 31, 41 from a line 52 and lines 52A, 52B. Fluid that has flowed through the top platens 31, 41 flows back to the system 50 via lines 54A, 54B, respectively, and a line 54.

20 Once the original screening material layers and screen support combination 12 have been moved from the heating apparatus 20, another set of such layers is emplaced on the base 22, the top platen 21 is lowered and the new screening material layers are heated. When the top platen 21 is then raised, the heated screening
25 material layers and screen support combination 12 are emplaced on the base 32 of the cooling apparatus 30. By the time yet another third set of screening material layers has been heated by the heating apparatus 20, the original screening material layers and screen support
30 combination 12 have been cooled in the cooling apparatus 40 and the third set of heated screening material layers is moved from the heating apparatus 20 to the cooling

- 16 -

apparatus 40 for cooling.

Figure 1C illustrates all three apparatuses 20, 30, 40 simultaneously in use with top platens in the lower positions. The top platens 21, 31 and 41 are independently movable with their respective piston and cylinders. Two sets of layers of screening material and screen support combination - each set previously heated by the heating apparatus 20 - are each being cooled, one in the cooling apparatus 30 and one in the cooling apparatus 40. A third set of layers of screening material and screen support combination is, at the same time, being heated in the heating apparatus 20.

Figure 2A shows one embodiment of a flow system for flowing cooling fluid through a base platen such as the base platen 32, 42 shown in Figure 1A-F or for flowing cooling fluid through a top platen 31, 41 of a cooling apparatus 30, 40.

As shown in Figure 2A cooled fluid from a cooled fluid system 60 (for example, but not limited to, like the system 50 described above or any suitable known system for providing cooled fluid) flows out in a line 61 and then from the line 61 in sub-lines 62 which pass through a member 63 (for example, a base platen or top platen as described above). Via loop ends 64 (which may be outside the member 63 as shown or within the member 63) the fluid flows back to a return line 65. The return line 65 is in fluid communication with the system 60 and the fluid from the member 63 flows back into the system 60 via the return line 65 for re-cooling and re-introduction into the line 61.

Figure 2B illustrates an alternative flow scheme in which cooled fluid from the cooled fluid system 60 flows

- 17 -

in a line 66 to a manifold 66a. Fluid flows in sub-lines 67 which are in fluid communication with the manifold 66a across the member 63 to a return manifold 68. From the return manifold 68 fluid flows to a return line 69 and then back to the system 60 for re-cooling and re-use.

Figure 1D illustrates a control panel 70 with controls for controlling the heating apparatus 20. The control panel 70 is interconnected via lines in conduits 27K (shown schematically, Figure 1D) with heating apparatuses 27 and the temperature sensors and includes controls for setting and controlling the temperature of the top platen 21 and the base 22.

Figure 4C shows the heated platen apparatus 20 (see Figures 1A - 1C). Both the top platen 21 and the base 22 have a series of heat rods in channels therethrough from one side to the other labelled with numerals from 1 to 11 in Figure 4C in which are positioned the heating elements 21h, 22h.. Six thermal sensors, 27a-27f, in the top platen 21 (27a-27c) and the base 22 (27d-27f) provide measurements of temperature for the edges and mid-portion of a screen layer combination on the base 22 during heating of the screen layer combination.

Each sensor 27a-27f is in communication with control apparatus 27g of the heater system 27 and with the controls of the control panel 70. Upon sensing a temperature of a screen layer combination via one of the sensors 27a-27f, the heater system 27 can, if needed, increase (or decrease) the temperature at the zone or area corresponding to the particular sensor to insure that that zone or area of the screen layer combination is appropriately (and in particular cases uniformly) heated. For example, in one particular situation, if one or both

- 18 -

outer edges (as viewed in Figure 4C) of a screen layer combination adjacent channels 1, 2 and 10, 11 cool too quickly or heat up too slowly (as indicated by one or all of sensors 27a, 27c, 27d, and/or 27f) additional heat is supplied via the corresponding channels so that the screen layer combination is uniformly heated. It is also within the scope of the present invention to use the heating apparatus 20 to heat different zones or areas of a screen layer combination differently.

Figure 4D shows part of the system 10 in detail. The hydraulic pump apparatus 26 provides power for the movement apparatus 23, which, in one aspect, applies about 31 bars (450 p.s.i.) to items on the base platen 22. Pneumatic apparatuses 71 and 73 move the top platens 31 and 41 respectively. Air under pressure is supplied to the pneumatic apparatuses 71 and 73 by an air compressor apparatus 72 (shown schematically) or other suitable air supply system.

In certain particular aspects of methods in accordance with the present invention the temperature of the base 22 is set at about 32 Celsius (100 F) and the temperature of the top platen 21 is set at about 232 Celsius (450 F). A single layer of coarse mesh (e.g. 10 to 20 mesh) screen with a pattern of spaced-apart lines thereon of moisture-curing hot melt glue (which may or may not have been previously cured for several hours or days) is treated on the apparatus 20 (screen on base, top platen lowered) for about 30 seconds to one minute to soften the hot melt glue and the wire mesh. The top platen is then raised and a frame (e.g. but not limited to, a unibody frame or a frame made of channel or tubular members or rods) is placed on top of the coarse mesh

- 19 -

layer. The frame is coated with a powderized adhesive, e.g. known powder epoxy material. The top platen is then lowered and the powderized adhesive, following heating, flows down onto the wire of the coarse mesh layer. After
5 about six to eight minutes, the top platen is raised and the frame -coarse-mesh combination remains on the heated base until substantially all of the epoxy material is "set up" or hardened. By raising the top platen after a certain time period (e.g. six to eight minutes or
10 whatever is required) the hot melt glue is not permitted to heat to such a level that it degrades or burns. Therefore, the top platen is raised so that the epoxy material can continue to heat to a point at which good encapsulation of wires of the coarse mesh layer is
15 accomplished, but with no or minimal degradation of the hot melt glue in the coarse mesh layer. In another aspect, instead of a single coarse mesh layer, a combination of two, three or more glued-together layers (any disclosed or referred to herein; e.g., with layers
20 glued-together with moisture-curing hot melt glue) are initially placed on the base of the heating apparatus 20. The resulting screen assembly can be cooled on one of the cooling apparatuses.

38. In another aspect, a coarse mesh layer with a
25 pattern (any disclosed or referred to herein) of moisture-curing hot melt glue thereon is placed on the base 22, heated for about 30 seconds, then one or two layers of fine screening mesh are placed on top of the coarse mesh layer and the top platen is lowered to heat
30 the combination of the three layers. The top platen is then raised, the screen layer combination is moved to one of the cooling apparatuses, and the heating apparatus

- 20 -

begins to treat another screen layer combination.

In one particular embodiment of a method in accordance with the present invention, a layer of coarse mesh (10 to 20 mesh) with hot melt glue thereon is placed on a layer of fine mesh (38 - 400 mesh) which is on a layer of fine mesh (30 to 325 mesh). Either or both layers of fine mesh may also have hot melt glue thereon. This multi-layered combination is placed on a base of a heating apparatus in accordance with the present invention with the base at a temperature between 400 to 440 F (in one aspect on a base as shown in Figure 4C the heating elements for the channels 1, 2, 10, and 11 are heated to between 415 and 440 F and the remaining heating elements are heated to between 400 and 440 F. The top platen is lowered onto the multi-layered combination which is heated for about 3 to 5 minutes. The top platen is then raised and the glued-together combination is moved to one of the cooling apparatuses and, in one aspect, another multi-layered combination is simultaneously placed on the base of the heating apparatus.

39. Any screen assembly made in accordance with the present invention may be a screen assembly for use on a vibratory separator and, in one particular aspect, a screen assembly for use on a shale shaker used for treating drilling fluid with drilled cuttings, debris, and/or contaminants therein, such a screen assembly able to withstand vibratory forces imparted thereto by vibration apparatus of the vibratory separator or shale shaker.

40. The present invention, therefore, in at least some, but not necessarily all embodiments, provides a

- 21 -

method for making a screen assembly [in one aspect, a glued-together screen assembly] for use in a vibratory separator, the method including producing at least one layer of screening material with a glue [or adhesive] pattern on the surface thereof, placing the at least one layer of screening material on heating apparatus, heating the at least one layer of screening material with the heating apparatus, optionally placing a secondary member on the at least one layer of screening material, heating together the at least one layer of screening material [when this is more than one layer] and/or the secondary member [when one is present] to combine the at least one layer of screening material and the at least one secondary member forming a first screen assembly. Such a method may include one or some, in any possible combination, of the following: wherein the at least one layer of screening material is or includes a layer of coarse mesh; wherein the pattern is glue and glue of the pattern on the at least one layer of screening material is cured glue prior to placing the at least one layer of screening material on the heating apparatus; wherein glue of the pattern is moisture-curing hot melt glue; wherein the at least one layer of screening material is heated sufficiently to soften glue of the glue pattern; wherein the secondary member is at least one layer of secondary screening material; wherein the secondary screening material includes a fine mesh; wherein the at least one layer of secondary screening material is two layers of secondary screening material; wherein the two layers of secondary screening material are glued together; wherein the secondary member is a frame for a screen assembly; wherein the frame is an array of tubular members; wherein

- 22 -

the frame is coated with adhesive material; wherein the frame [or a frame and a secondary member] is heated sufficiently so that at least some of the adhesive material flows onto the at least one layer of screening material to adhere together the secondary member and the at least one layer of screening material; wherein the adhesive material is powderized epoxy material; removing the first screen assembly from the heating apparatus, emplacing the first screen assembly on first cooling apparatus adjacent the heating apparatus, and cooling the first screen assembly with the cooling apparatus; while the first screen assembly is cooling, forming a second screen assembly as described above; removing the second screen assembly from the heating apparatus, emplacing the second screen assembly on second cooling apparatus, and cooling the second screen assembly with the second cooling apparatus; while the second screen assembly is cooling, forming a third screen assembly as described above; and /or wherein the screen assembly is able to withstand vibratory forces imparted to a screen assembly by vibration apparatus of a vibratory separator or shale shaker.

The present invention, therefore, in at least some, but not necessarily all embodiments, provides a method for making a glued-together screen assembly for use in a vibratory separator, the method including gluing together at least two layers of screening material with heated glue producing a glued-together screen combination, placing the glued-together screen combination on cooling apparatus, and cooling the heated glue with the cooling apparatus. Such a method may include one or some, in any possible combination, of the

various aspects referred to in the previous paragraph.

The present invention, therefore, in at least some, but not necessarily all embodiments, provides a screen assembly made by any of the methods described
5 above.

The present invention, therefore, in at least some, but not necessarily all embodiments, provides a method for making a screen assembly for use in a vibratory separator, the method including producing at
10 least one layer of screening material with adhesive or glue thereof, placing the at least one layer of screening material on heating apparatus, heating the at least one layer of screening material with the heating apparatus, placing a frame on the at least one layer of screening
15 material on the heating apparatus, heating together the at least one layer of screening material and the frame to combine the at least one layer of screening material and the frame forming a screen assembly. Such a method may include placing a secondary member on the frame which
20 becomes part of the screen assembly.

Preferably, the heated platen has a surface which is approximately 1m by 1.2m i.e. the same size as a screen.

CLAIMS:

1. An apparatus for use in the making of a screen assembly, the apparatus comprising a platen (31,41,32,42) and a heat exchanger (62,67) for removing heat from said
5 platen.
2. An apparatus as claimed in Claim 1, wherein said heat exchanger comprises (62,67) at least one channel through which a coolant can flow.
3. An apparatus as claimed in Claim 1 or 2, wherein
10 said heat exchanger comprises a multiplicity of channels (62,67) through which a coolant can flow.
4. An apparatus as claimed in Claim 1, 2 or 3, wherein said coolant is a liquid.
5. An apparatus as claimed in any preceding claim,
15 further comprising a further platen (31,41,32,42), the platen (31,41,32,42) and the further platen (31,41,32,42) having surfaces which oppose one another between which said screen is arrangeable.
6. An apparatus as claimed in Claim 5, wherein said
20 further platen (31,41,32,42) comprises a heat exchanger.
7. An apparatus as claimed in Claim 5 or 6, wherein said further platen (31,41) is moveable in relation to said platen preferably, on a piston and cylinder.
9. An apparatus wherein said platen (31,41) or further
25 platen is arranged on springs (21c), such that the springs push on a screen in use.
10. An arrangement for use in the making of a screen assembly, the arrangement comprising the apparatus as claimed in any preceding claim, the arrangement further
30 comprising a heating apparatus for heating heat activated adhesive in a screen and screen support combination.
11. An arrangement as claimed in Claim 10, further

- 25 -

comprising a further apparatus as claimed in any of Claims 1 to 9.

12. An arrangement as claimed in Claim 10 or 11, wherein said apparatus and heating apparatus are mounted in a
5 frame.

13. A method for making a screen assembly, the method comprising the steps of placing a screen, a heat activated adhesive and a screen support in or on a heated apparatus to melt said heat activated adhesive,
10 characterised in that the method further comprises the steps of placing the screen, heat activated adhesive and screen support combination on or in a cooling platen provided with a heat exchanger to facilitate maintenance of the temperature of the cooling platen for cooling said
15 heat activated adhesive.

14. A method in accordance with Claim 13, wherein said screen is at least one layer of fine screening material.

15. A method in accordance with Claim 13 or 14, wherein said screen is at least two layers of screening material.

20 16. A method in accordance with any of Claims 13, 14 or 15, wherein said heated apparatus comprises a heated platen

17. A method in accordance with any of Claims 13 to 16, wherein said screen support comprises a frame.

25 18. A method in accordance with any of Claims 13 to 17, wherein said screen support comprises a coarse layer of supporting mesh.

19. A method in accordance with any of Claims 13 to 18, wherein said screen support comprises a perforated plate.

30 20. A method in accordance with Claim 13 to 19, wherein the cool platen is maintained at substantially room temperature.

- 26 -

21. A method in accordance with any of Claims 14 to 20, wherein the at least one layer of screening material is a layer of coarse mesh.
22. A method in accordance with any of Claims 14 to 21,
5 wherein said heat activated glue is applied in a pattern on the at least one layer of screening material and is cured glue prior to placing the at least one layer of screening material on the heating apparatus.
23. A method in accordance with any of Claims 14 to 22,
10 wherein said heat activated adhesive is moisture-curing hot melt glue.
24. A method in accordance with any of Claims 14 to 23, wherein the at least one layer of screening material is heated sufficiently to soften the heat activated glue.
- 15 25. A method in accordance with any of Claims 14 to 24, wherein the screen support is heated sufficiently so that at least some of the adhesive material flows onto the screen to adhere together the screen support and the screen.
- 20 26. A method in accordance with any of Claims 14 to 24, wherein the heat activated adhesive material is powderized epoxy material.
27. A method in accordance with any of Claims 14 to 26,
25 further comprising the steps of placing a second screen, heat activated adhesive and screen support combination in the heating apparatus, and heating said heat activated adhesive and placing the screen, heat activated adhesive and screen support combination on or in a second cooling platen provided with a heat exchanger to facilitate
30 maintenance of the temperature of the cooling platen for cooling said heat activated adhesive.
28. A method in accordance with Claim 27, further

- 27 -

comprising the steps of placing a third screen, heat activated adhesive and screen support combination in the heating apparatus, and heating said heat activated adhesive.

5 29. An apparatus for use in the making of a screen assembly, the apparatus comprising a platen (21,22) and a plurality of elements (22h) through which electric current flows for heating said platen (21,22) characterised in that said platen (21,22) further
10 comprises at least one sensor (27a-f) for measuring the temperature of said platen (21,22).

30. An apparatus as claimed in Claim 29, further comprising at least one further sensor (27a-f) each sensor for measuring the temperature of a portion of said
15 platen (21,22).

31. An apparatus as claimed in Claim 29 or 30, wherein said platen (21,22) comprises a plurality of sensors (27a-f), each for measuring the temperature of a portion of said platen.

20 32. An apparatus as claimed in Claim 29 to 31, including means for individually controlling the heat generated by each element (22h).

33. An apparatus as claimed in Claim 32, further comprising a feed back control circuit for analysing the
25 data received from the sensors and controlling the flow of current through each element.

34. An apparatus for use in the making of a screen assembly, the apparatus comprising a platen (21,22) having zones and a plurality of elements (22h) through
30 which electric current flows for heating said platen (21,22) characterised in that said elements (22h) are independently controllable for independently controlling

- 28 -

the temperature of said zones in said platen (21,22).

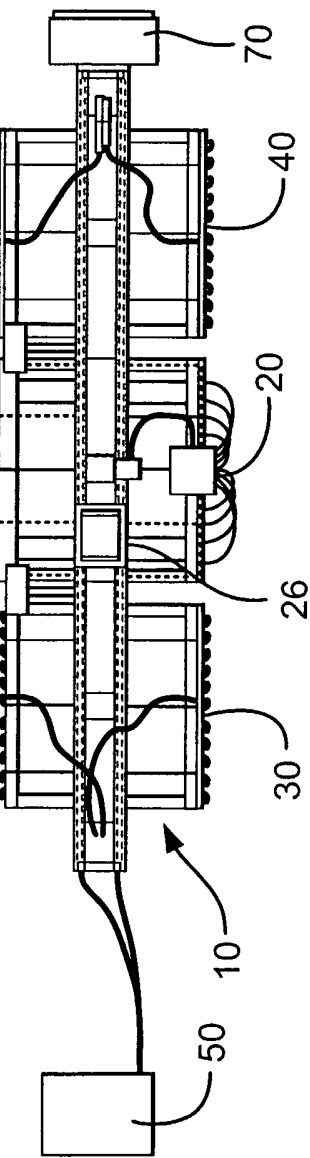

Fig. 1A

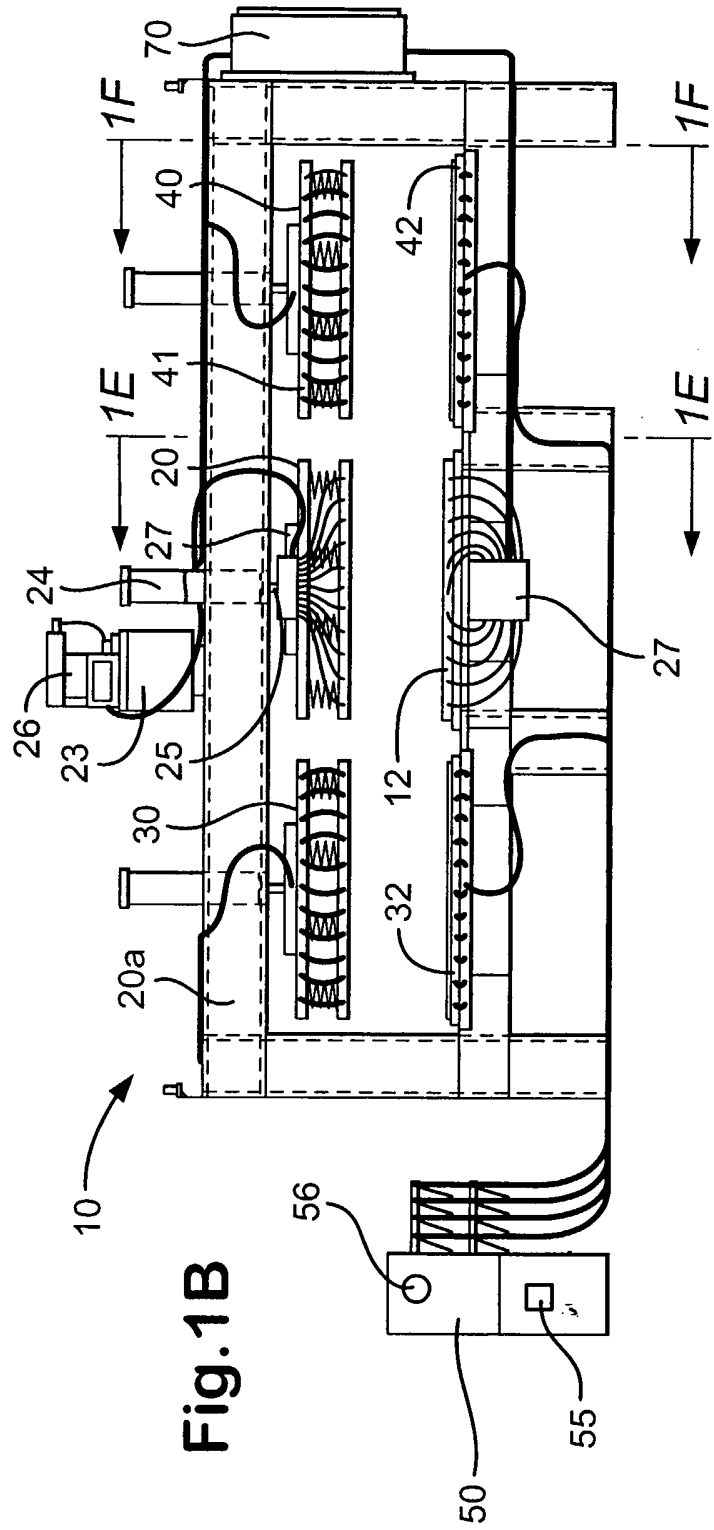

Fig. 1B

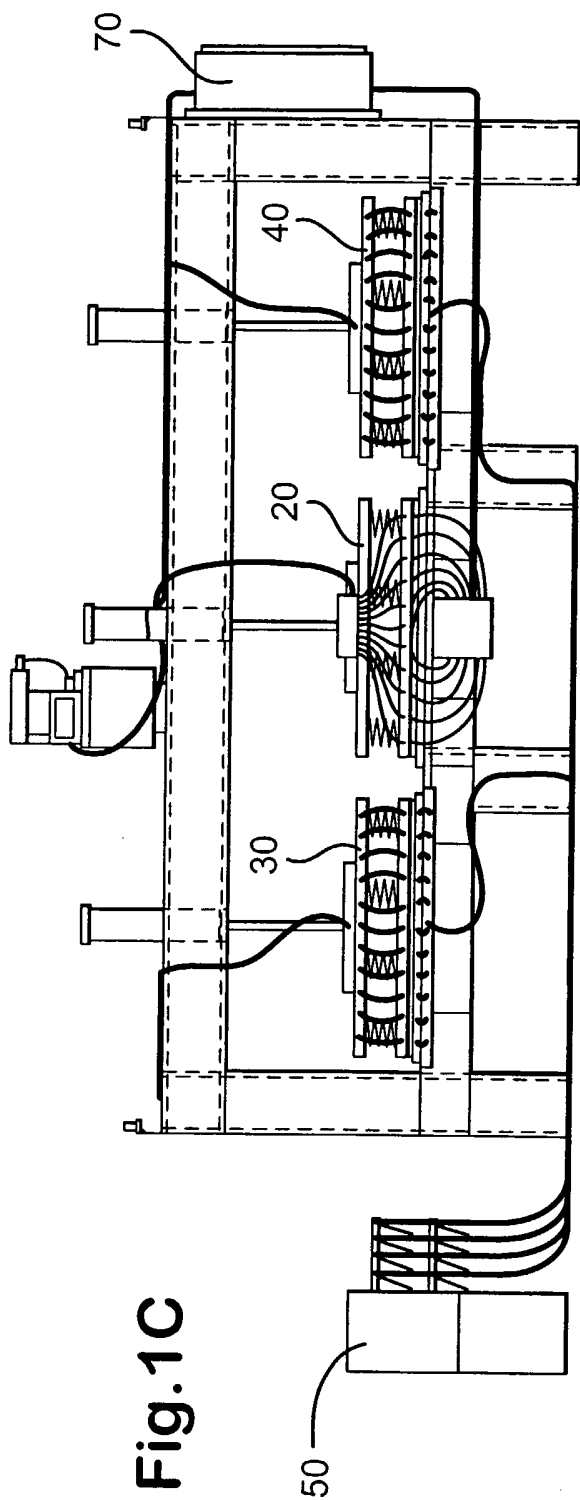

Fig.1C

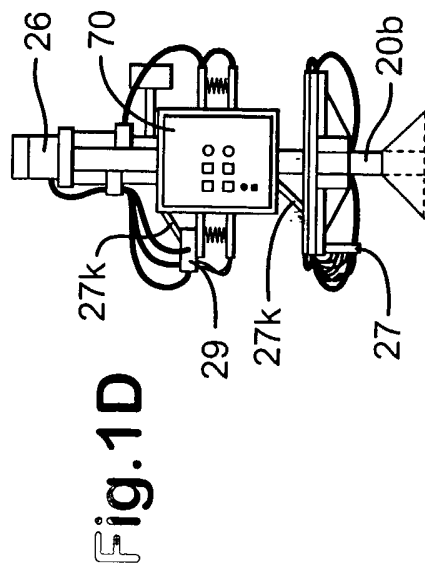

Fig.1D

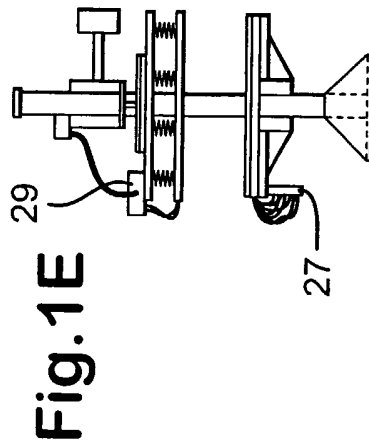

Fig.1E

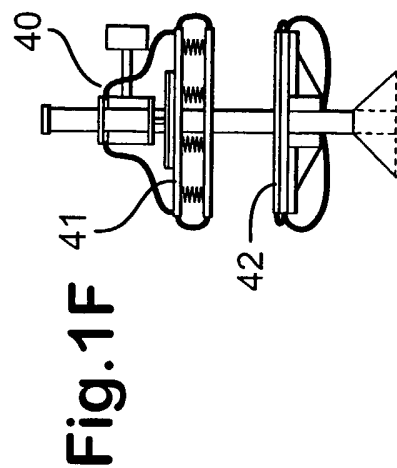

Fig.1F

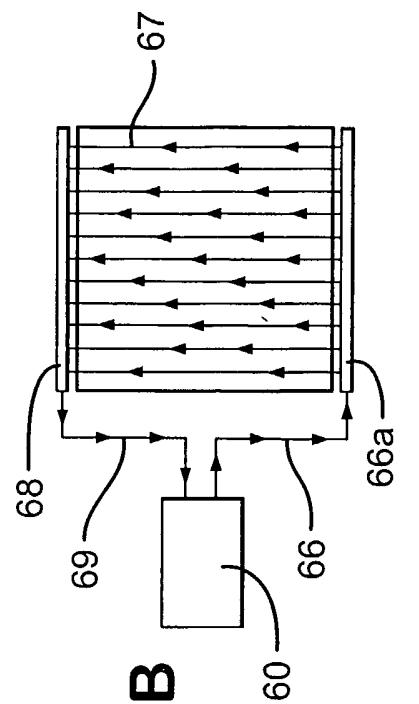

Fig. 2A

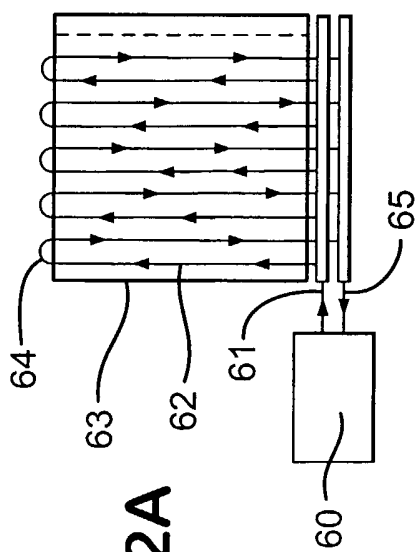

Fig. 2B

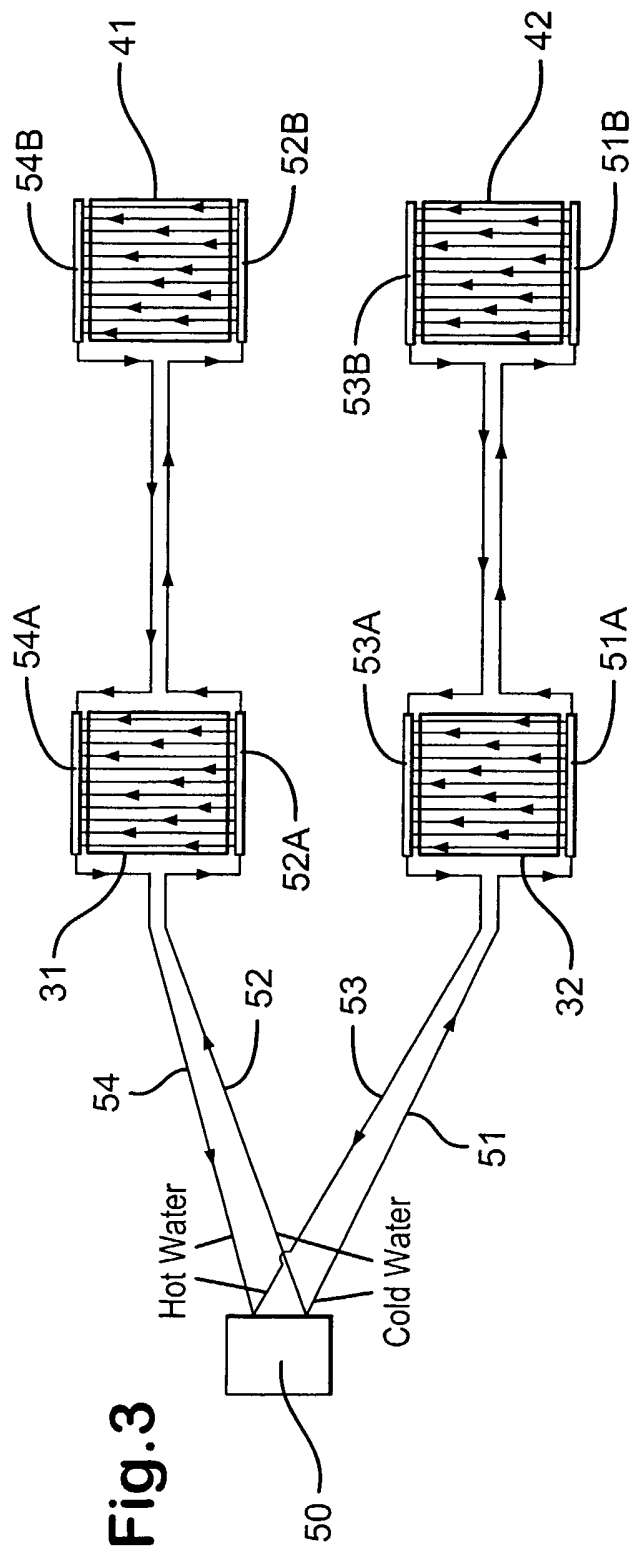

Fig. 3

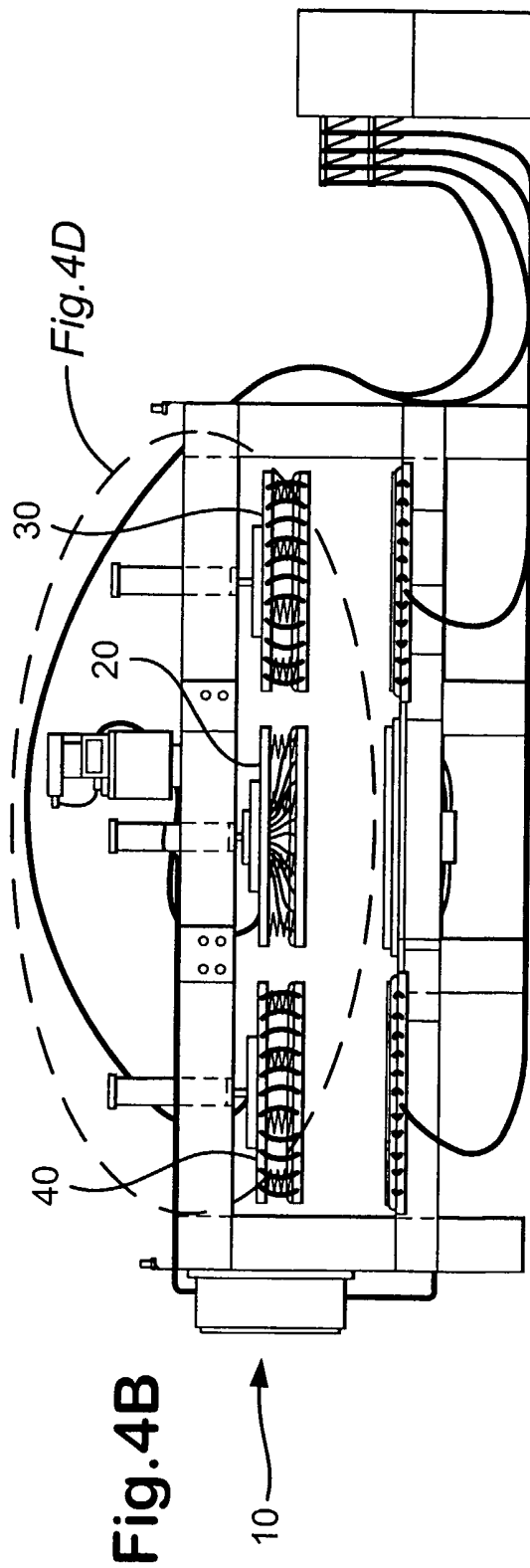
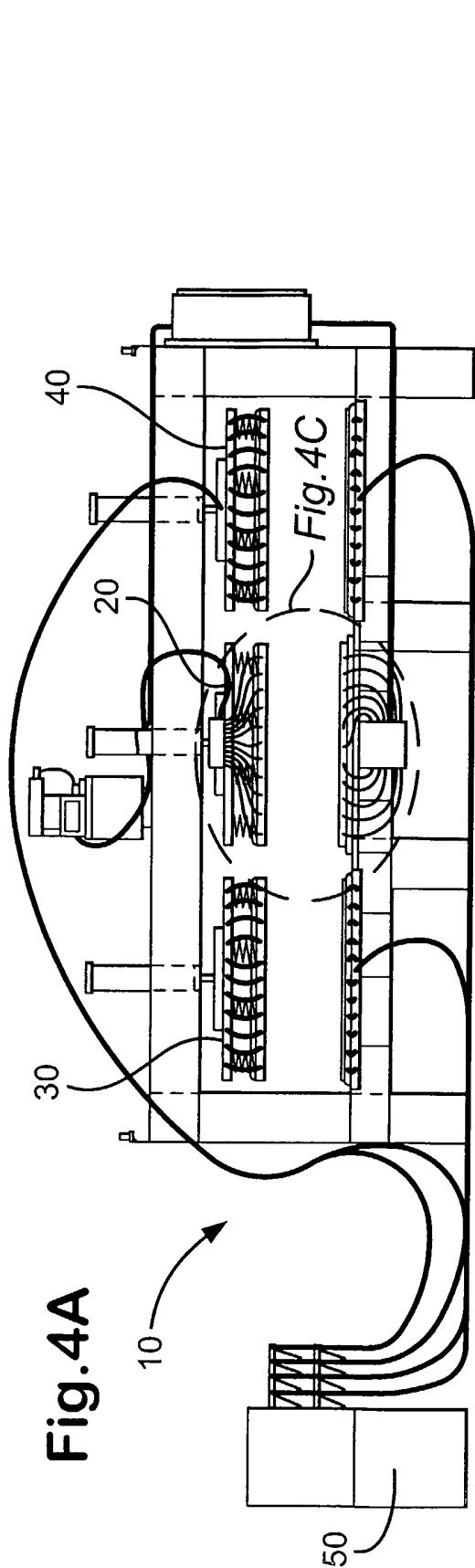

Fig.4C

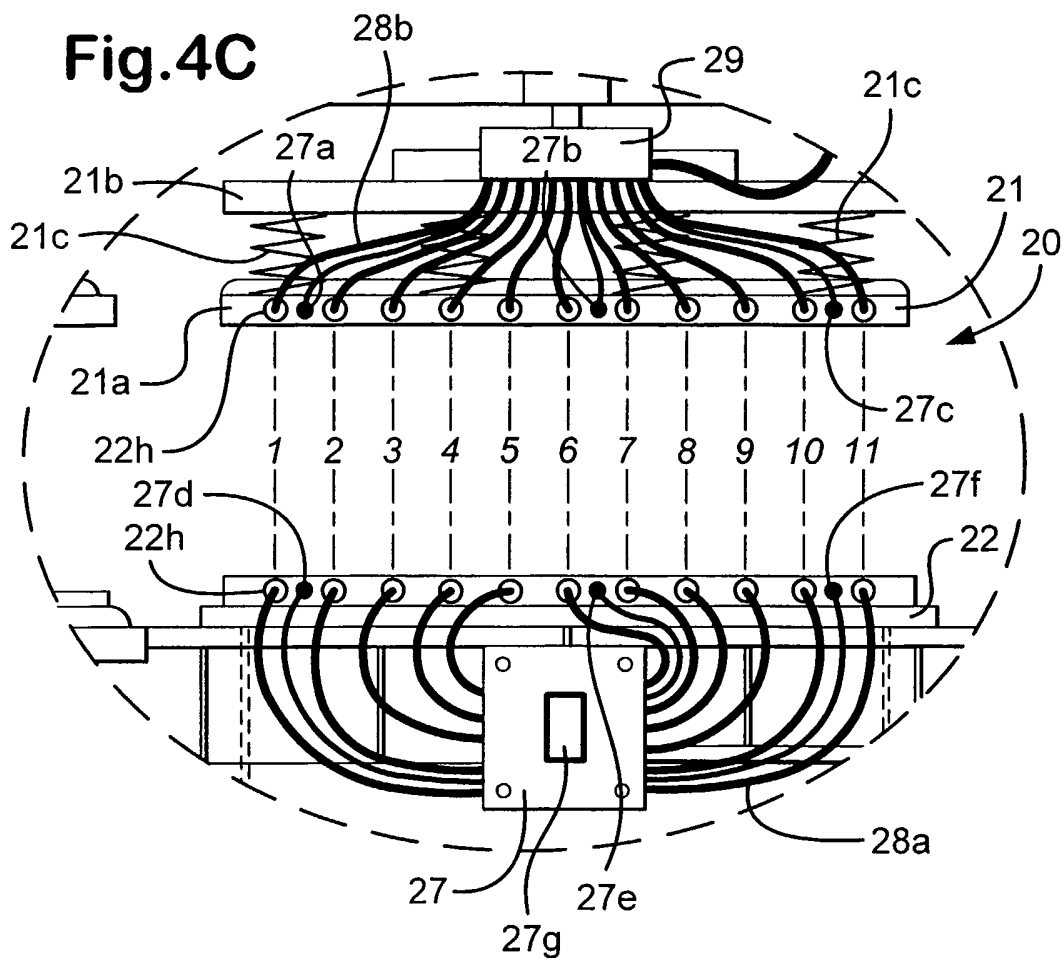

Fig.4D

