

(19) **DANMARK**

(10) **DK/EP 4217551 T3**



(12) **Oversættelse af  
europæisk patentskrift**

Patent- og  
Varemærkestyrelsen

- 
- (51) Int.Cl.: **E 04 C 3/04 (2006.01)** **E 04 B 1/58 (2006.01)** **E 04 C 3/07 (2006.01)**  
**F 16 B 7/18 (2006.01)**
- (45) Oversættelsen bekendtgjort den: **2024-08-26**
- (80) Dato for Den Europæiske Patentmyndigheds bekendtgørelse om meddelelse af patentet: **2024-07-17**
- (86) Europæisk ansøgning nr.: **21839283.5**
- (86) Europæisk indleveringsdag: **2021-11-25**
- (87) Den europæiske ansøgnings publiceringsdag: **2023-08-02**
- (86) International ansøgning nr.: **PL2021000084**
- (87) Internationalt publikationsnr.: **WO2022191722**
- (30) Prioritet: **2021-03-08 PL 43724521**
- (84) Designerede stater: **AL AT BE BG CH CY CZ DE DK EE ES FI FR GB GR HR HU IE IS IT LI LT LU LV MC MK MT NL NO PL PT RO RS SE SI SK SM TR**
- (73) Patenthaver: **Thale Sp. z o.o. Sp.k, Wilimowo 2, 11-041 Olsztyn, Polen**
- (72) Opfinder: **NICZUK, Jakub, , 10-187 Olsztyn, Polen**
- (74) Fuldmægtig i Danmark: **Plougmann Vingtoft A/S, Strandvejen 70, 2900 Hellerup, Danmark**
- (54) Benævnelse: **MONTERINGSPROFIL**
- (56) Fremdragne publikationer:  
**EP-A2- 1 640 524**  
**WO-A1-2016/154656**



# DESCRIPTION

Description

## Technical Field

[0001] The invention relates to a mounting profile for supporting installations used in construction.

## Background Art

[0002] From publication EP 1 640 524 A2 a construction module is known for making a support especially for pipelines. The module comprises a base element shaped as a closed profile which is provided on at least one side with fastening openings at fixed intervals for fastening at least one other base element and/or piece of equipment by means of fastening screws wherein the fastening screws cooperate during fastening with the fastening openings as tools for embossing or cutting threads. The fastening openings are positioned in embossed ribs. Thus, the embossed ribs, the fastening openings and the fastening screws are mutually compatible so that the fastening screws emboss or cut a thread in the fastening openings and in the side walls of the embossed ribs.

[0003] The solution known in the prior art does not solve the problem of security and durability of the connection between the profile and the fastened element. Between the profile and the fastened element there is a free space which is deformable and may damage the connection.

## Disclosure of Invention

[0004] A mounting profile according to the invention, formed of a longitudinal closed profile with a polygonal cross-section, having at least four side walls, comprising on at least one side wall a fastening assembly including two longitudinally extending outer rows of openings which are positioned at the longitudinal edges of the side wall, at least one longitudinally extending inner row of openings and at least two longitudinally extending embossed ribs directed inwardly the profile, is characterized in that the embossed ribs are positioned between the outer rows of openings and the inner row of openings.

[0005] Preferably, the outer row of openings includes circular openings and the inner row of openings includes circular openings and oblong openings.

**[0006]** Preferably, the circular openings and the oblong openings in the inner row of openings are arranged alternately.

**[0007]** Preferably, the oblong openings in the inner row of openings have a larger surface area in a plane perpendicular to the opening axis than the circular openings.

**[0008]** Preferably, the circular openings in the outer row of openings are equally spaced along the length of the profile.

**[0009]** Preferably, the circular openings in the outer rows of openings, positioned on the same side wall, are offset from each other in the longitudinal direction of the profile by a value equal to half the space between the circular openings.

**[0010]** Preferably, the circular openings in the outer row of openings and the circular openings in the inner row of openings are self-tapping screw openings.

**[0011]** Preferably, the outer rows of openings in the fastening assembly are positioned symmetrically to the inner row of openings. Preferably, the embossed ribs are positioned symmetrically to the inner row of openings.

**[0012]** Preferably, the mounting profile is formed of a longitudinal closed profile with a trapezoidal cross-section.

**[0013]** Preferably, the mounting profile is formed of a longitudinal closed profile with a rectangular cross-section.

**[0014]** Preferably, the mounting profile is formed of an oblong closed profile with a square cross-section.

**[0015]** Preferably, the mounting profile comprises one fastening assembly formed on the side wall associated to the longer trapezoidal base.

**[0016]** Preferably, the mounting profile formed of an oblong closed profile with a rectangular cross-section comprises two fastening assemblies, one on each of the two opposite side walls, wherein the fastening assemblies being formed on the side walls constituting the shorter sides of the rectangular cross section, or the fastening assemblies being formed on the side walls forming the longer sides of the rectangular cross-section.

**[0017]** Preferably, the mounting profile is formed of an oblong closed profile with a square cross-section and includes four fastening assemblies, one on each side wall.

**[0018]** Preferably, the mounting profile is formed of an oblong closed profile with a hexagonal cross-section, and includes two fastening assemblies, one on each of the two opposing side

walls. Preferably, the mounting profile is formed of an oblong closed profile with a hexagonal cross-section, wherein the hexagon being a regular hexagon, and includes six fastening assemblies, one on each side wall

**[0019]** Preferably, the mounting profile is formed of an oblong closed profile with an octagonal cross-section.

**[0020]** Preferably, the mounting profile is formed of an oblong closed profile with an octagonal cross-section and includes four fastening assemblies, one on each side wall forming two pairs of opposing side walls.

**[0021]** Preferably, the mounting profile is formed of an oblong closed profile with an octagonal cross-section and includes eight fastening assemblies, one on each side wall.

**[0022]** The solution according to the invention allows for obtaining a profile with greater strength than the solution known in the prior art. The mounting profile adheres closely to the fastened element without free space at the connection point, which increases the safety and durability of the connection, and thus of the constructed structures.

**[0023]** Additionally, thanks to the use of longitudinal embossed ribs the cross-sectional area of the mounting profile increases (without changing the external dimensions), and thus increases bending and torsional strength of the profile.

**[0024]** The use of an internal row of openings allows the mounting profile to be joined with a fastened element also with a round head square neck bolt (a carriage bolt), thanks to which the mounting profile according to the present invention can be used in structures and installations existing on the market. Accordingly, the solution according to the invention is universal - it can be used both for the design of new systems and for the modernization or extension of the existing ones.

**[0025]** With a sufficiently dense perforation of the openings for self-tapping screws the mounting profile according to the invention gives the ease of configuring any connections of the structure and the ease of adjustment in the event of a change in the design input assumptions.

**[0026]** The use of openings for self-tapping screws, such as e.g. Taptite<sup>®</sup> self-tapping screws, allows to significantly reduce the time needed for assembly (no drilling, threading) and does not require any additional processes such as welding.

**[0027]** The oblong openings placed in the inner row enable fastening with a self-tapping screw directly to the octagonal connector as well as pass-through suspension of the element to the profile by a round head square neck bolt (a carriage bolt), e.g. M10. Mounting of accessories to the profile using self-tapping screws is carried out only on one side without the need for using nuts. Mounting without the use of washers and nuts is also possible with the use of self-

tapping screws with a serrated collar to prevent self-loosening. Accordingly, the mounting profile according to the invention is highly versatile and easy to handle.

**Brief Description of Drawings**

[0028] The object of the invention is illustrated in embodiments in the drawing, in which

fig. 1 shows a perspective view of a first embodiment of a mounting profile according to the invention,

fig. 2 shows a cross-section of a first embodiment of a mounting profile according to the invention,

fig. 3 shows a perspective view of the second embodiment of a mounting profile according to the invention,

fig. 4 shows a cross-section of a second embodiment of a mounting profile according to the invention,

fig. 5 shows a perspective view of a third embodiment of a mounting profile according to the invention,

fig. 6 shows a cross-section of a third embodiment of a mounting profile according to the invention,

fig. 7 shows a perspective view of a fourth embodiment of a mounting profile according to the invention,

fig. 8 shows a cross-section of a fourth embodiment of a mounting profile according to the invention,

fig. 9 shows a perspective view of a fifth embodiment of a mounting profile according to the invention,

fig. 10 shows a cross-section of a fifth embodiment of a mounting profile according to the invention.

fig. 11 shows a perspective view of a sixth embodiment of a mounting profile according to the invention,

fig. 12 shows a cross-section of a sixth embodiment of a mounting profile according to the invention,

fig. 13 shows a perspective view of a seventh embodiment of a mounting profile according to the invention,

fig. 14 shows a cross-section of a seventh embodiment of a mounting profile according to the

invention,

fig. 15 shows a perspective view of an eighth embodiment of a mounting profile according to the invention,

fig. 16 shows a cross-section of an eighth embodiment of a mounting profile according to the invention,

fig. 17 shows a perspective view of a ninth embodiment of a mounting profile according to the invention,

fig. 18 shows a cross-section of a ninth embodiment of a mounting profile according to the invention,

fig. 19 shows a perspective view of a tenth embodiment of a mounting profile according to the invention,

fig. 20 shows a cross-section of a tenth embodiment of a mounting profile according to the invention,

### **Modes for Carrying Out the Invention**

**[0029]** A first embodiment of a mounting profile according to the invention is shown in figures 1 and 2. The mounting profile is formed of a longitudinal closed profile with a trapezoidal cross-section having a longitudinal direction X extending parallel to the longitudinal edges of the profile. The arms of the trapezoidal cross-section have equal length.

**[0030]** The closed profile comprises four side walls W. The side wall W, which is the longer base of the trapezoidal cross-section, includes two longitudinally extending outer rows 1 of openings, one longitudinally extending inner row 3 of openings and two longitudinally extending embossed ribs 2. The directions in which the rows 1 and 3 extend are consistent with the longitudinal direction X.

**[0031]** The outer rows 1 of openings are positioned at the longitudinal edges of the side wall W, the inner row 3 of openings is positioned halfway the width of the side wall W, and the embossed ribs 2 are positioned between the outer rows 1 of openings and the inner row of openings. The outer rows 1 of openings and the embossed ribs 2 are arranged symmetrically on both sides with respect to the inner row 3 of openings. The outer rows 1 of openings are formed on the flat surface of the side wall W, between the embossed ribs 2 and the longitudinal edges of the mounting profile. The embossed ribs 2 are placed on the surface of the side wall W of the mounting profile and are directed towards the inside of the profile.

**[0032]** Two outer rows 1 of openings, one inner row 3 of openings and two embossed ribs 2,

positioned relative to each other as described above, form the fastening assembly of the mounting profile. The first embodiment of the invention thus comprises one fastening assembly on one side wall W.

**[0033]** The outer rows 1 of openings include circular openings 11, while the inner row 3 of openings includes alternately placed circular openings 31 and oblong openings 32. The oblong openings 32 have a larger surface area in the plane perpendicular to the opening axis than the circular openings 31. Moreover, the dimension of the oblong openings 32 in the direction perpendicular to the longitudinal direction X of the mounting profile is greater than the diameter of the circular openings 31. In the outer row 1 of openings, circular openings 11 are equally spaced along the profile. The circular openings 11 of the outer rows 1 are offset from each other in the longitudinal direction of the profile by a value equal to half the space between the circular openings 11. The circular openings 11, positioned in the outer row 1 of openings, and the circular openings 31, positioned in the inner row 3 of openings, are openings for self-tapping screws.

**[0034]** On the remaining side walls W the mounting profile according to the present embodiment comprises additional longitudinally extending rows 4 of circular openings 41. The directions in which the additional rows 4 extend are consistent with the longitudinal direction X.

**[0035]** Each of the additional rows 4 of openings is positioned in the half of the width of the side wall W.

**[0036]** Circular openings 41 are equally spaced along the profile. The circular openings 41, positioned on the opposite side walls W, constituting the arms of the trapezoidal cross-section, are offset from each other by a value equal to half the space between the circular openings 41. The circular openings 41, positioned in the additional row 4 of openings, are openings for self-tapping screws.

**[0037]** A second embodiment of a mounting profile according to the invention is shown in figures 3 and 4. The mounting profile is formed of a longitudinal closed profile with a rectangular cross-section having a longitudinal direction X extending parallel to the longitudinal edges of the profile.

**[0038]** The closed profile includes four side walls W.

**[0039]** The second embodiment of the invention includes two fastening assemblies, one on each of the opposing side walls W representing the longer sides of the rectangular cross section.

**[0040]** The outer rows 1 of openings include circular openings 11, while the inner row 3 of openings include alternately placed circular openings 31 and oblong openings 32. The oblong openings 32 have a larger surface area in the plane perpendicular to the opening axis than the circular openings 31. Moreover, the dimension of the oblong openings 32 in the direction

perpendicular to the longitudinal direction X of the mounting profile is greater than the diameter of the circular openings 31. In the outer row 1 of openings, circular openings 11 are equally spaced along the profile. The circular openings 11 of the outer rows 1, positioned on the same side wall W, are offset from each other in the longitudinal direction of the profile by a value equal to half the space between the circular openings 11. Likewise, the circular openings 11 of the opposite outer rows 1, positioned on the opposite side walls W, are also offset from each other in the longitudinal direction of the profile by a value equal to half the space between the circular openings 11. The circular openings 11 in the outer row 1 of openings and the circular openings 31 in the inner row 3 of openings are openings for self-tapping screws.

**[0041]** Each of the side walls W, being the shorter, opposite sides of the rectangular cross-section, comprises one additional longitudinally extending row 4 of circular openings 41 and two longitudinally extending embossed ribs 2. The directions in which the additional rows 4 of openings and the embossed ribs 2 extend are consistent with the longitudinal direction X.

**[0042]** The embossed ribs 2 are positioned at the longitudinal edges of the side wall W, while each of the additional rows 4 of openings is positioned in the half of the width of the side wall W.

**[0043]** In the additional row 4 of openings, circular openings 41 are equally spaced along the profile. Circular openings 41 of additional rows 4, positioned on opposite side walls W, are offset from each other in the longitudinal direction of the profile by a value equal to half the distance between them. The circular openings 41 contained in the additional row 4 of openings are self-tapping screw openings.

**[0044]** A third embodiment of a mounting profile according to the invention is shown in figures 5 and 6. The mounting profile is formed by a longitudinal closed profile with a rectangular cross-section having a longitudinal direction X extending parallel to the longitudinal edges of the profile.

**[0045]** The closed profile comprises four side walls W.

**[0046]** The third embodiment of the invention includes two fastening assemblies, one on each of the opposing side walls W representing the longer sides of the rectangular cross section.

**[0047]** The outer rows 1 of openings comprise circular openings 11, while the inner row 3 of openings comprises alternately placed circular openings 31 and oblong openings 32. The oblong openings 32 have a larger surface area in the plane perpendicular to the opening axis than the circular openings 31. Moreover, the dimension of the oblong openings 32 in the direction perpendicular to the longitudinal direction X of the mounting profile is greater than the diameter of the circular openings 31. In the outer row 1 of openings, circular openings 11 are equally spaced along the profile. The circular openings 11 of the outer rows 1, located on the same side wall W, are offset from each other in the longitudinal direction of the profile by a value equal to half the space between the circular openings 11. The circular openings 11 of the

opposite outer rows 1, positioned on the opposite side walls W, are not offset from each other in the longitudinal direction. The circular openings 11 in the outer row 1 of openings and the circular openings 31 in the inner row 3 of openings are openings for self-tapping screws.

**[0048]** Each of the side walls W, being the shorter, opposite sides of the rectangular cross-section, includes one additional longitudinally extending row 4 of circular openings 41. The extension directions of the additional rows 4 of openings follow the longitudinal direction X.

**[0049]** Additional rows 4 of openings are positioned in the middle of the width of the side walls W.

**[0050]** In the additional row 4 of openings, circular openings 41 are equally spaced along the profile. The circular openings 41 of additional rows 4, positioned on the opposite side walls W, are not offset from each other in the longitudinal direction of the profile. The circular openings 41 contained in the additional row 4 of openings are self-tapping screw openings.

**[0051]** A fourth embodiment of a mounting profile according to the invention is shown in figures 7 and 8. The mounting profile is formed by a longitudinal closed profile with a rectangular cross-section having a longitudinal direction X extending parallel to the longitudinal edges of the profile.

**[0052]** The closed profile comprises four side walls W.

**[0053]** The fourth embodiment of the invention includes two fastening assemblies, one on each of the opposing side walls W representing the shorter sides of the rectangular cross section.

**[0054]** The outer rows 1 of openings include circular openings 11, while the inner row 3 of openings include alternately placed circular openings 31 and oblong openings 32. The oblong openings 32 have a larger surface area in the plane perpendicular to the opening axis than the circular openings 31. Moreover, the dimension of the oblong openings 32 in the direction perpendicular to the longitudinal direction X of the mounting profile is greater than the diameter of the circular openings 31. In the outer row 1 of openings, circular openings 11 are equally spaced along the profile. The circular openings 11 of the outer rows 1, positioned on the same side wall W, are offset from each other in the longitudinal direction of the profile by a value equal to half the space between the circular openings 11. Likewise, the circular openings 11 of the opposite outer rows 1, positioned on the opposite side walls W, are also offset from each other in the longitudinal direction of the profile by a value equal to half the space between the circular openings 11. The circular openings 11 in the outer row 1 of openings and the circular openings 31 in the inner row 3 of openings are openings for self-tapping screws.

**[0055]** Each of the side walls W, constituting the longer, opposite sides of the rectangular cross-section, comprises two longitudinally extending outer rows 1 of openings, two longitudinally extending inner rows 3 of openings, four longitudinally extending embossed ribs

2 and two additional longitudinally extending rows 4 of openings. The directions in which the rows 1, 3 and 4 of openings and the embossed ribs extend are consistent with the longitudinal direction X.

**[0056]** The outer rows 1 of openings are positioned at the longitudinal edges of the side wall W, the additional rows 4 of openings are positioned next to each other substantially in the middle of the width of the side wall W, the inner rows 3 of openings are positioned between the outer rows 1 of openings and the additional rows 4 of openings, while the embossed ribs 2 are positioned between the outer rows 1 of openings and the inner rows 3 of openings and between the inner rows 3 of openings and additional rows 4 of openings.

**[0057]** In the additional row 4 of openings, the circular openings 41 are equally spaced along the profile. The circular openings 41 in the directly adjacent additional rows 4 of openings are offset from each other in the longitudinal direction of the profile by a value equal to half the space between the circular openings 41. Likewise, the openings of the additional rows 4, positioned on the opposite side walls W, are offset from each other in the longitudinal direction of the profile by a value equal to half the space between the circular openings 41. The circular openings 41 contained in the additional row 4 of openings are self-tapping screw openings.

**[0058]** A fifth embodiment of a mounting profile according to the invention is shown in figures 9 and 10. The mounting profile is formed of a longitudinal closed profile with a rectangular cross-section having a longitudinal direction X extending parallel to the longitudinal edges of the profile.

**[0059]** The closed profile comprises four side walls W.

**[0060]** The fifth embodiment of the invention includes two fastening assemblies, one on each of the opposing side walls W representing the shorter sides of the rectangular cross section.

**[0061]** The outer rows 1 of openings include circular openings 11, while the inner row 3 of openings include alternately placed circular openings 31 and oblong openings 32. The oblong openings 32 have a larger surface area in the plane perpendicular to the opening axis than the circular openings 31. Moreover, the dimension of the oblong openings 32 in the direction perpendicular to the longitudinal direction X of the mounting profile is greater than the diameter of the circular openings 31. In the outer row 1 of openings circular openings 11 are equally spaced along the profile. The circular openings 11 of the outer rows 1, located on the same side wall W, are offset from each other in the longitudinal direction of the profile by a value equal to half the space between the circular openings 11. Likewise, the circular openings 11 of the opposite outer rows 1, positioned on the opposite side walls W, are also offset from each other in the longitudinal direction of the profile by a value equal to half the space between the circular openings 11. The circular openings 11 in the outer row 1 of openings and the circular openings 31 in the inner row 3 of openings are openings for self-tapping screws.

**[0062]** Each of the side walls W constituting the longer, opposite sides of the rectangular

cross-section, comprises two longitudinally extending outer rows 1 of openings, two longitudinally extending embossed ribs 2 and four additional longitudinally extending rows 4 of openings. The directions in which the rows 1 and 4 and embossed ribs 2 extend are consistent with the longitudinal direction X.

**[0063]** The outer rows 1 of openings are positioned at the longitudinal edges of the side wall W, the additional rows 4 of openings are positioned next to each other between the embossed ribs 2, while the embossed ribs 2 are positioned between the outer rows 1 of openings and the additional rows 4 of openings.

**[0064]** In the additional row 4 of openings, circular openings 41 are equally spaced along the profile. The circular openings 41 in the directly adjacent additional rows 4 of openings are offset from each other in the longitudinal direction of the profile by a value equal to half the space between the circular openings 41. The openings of the additional rows 4, positioned on the opposite side walls W, are offset from each other in the longitudinal direction of the profile by a value equal to half the space between the circular openings 41. The circular openings 41 contained in the additional row 4 of openings are self-tapping screw openings.

**[0065]** A sixth embodiment of a mounting profile according to the invention is shown in figures 11 and 12. The mounting profile is formed of a longitudinal closed profile with a square cross-section having a longitudinal direction X extending parallel to the longitudinal edges of the profile.

**[0066]** The closed profile comprises four side walls W.

**[0067]** A sixth embodiment of the invention includes four fastening assemblies, one on each side wall W.

**[0068]** The outer rows 1 of openings include circular openings 11, while the inner row 3 of openings includes alternately placed circular openings 31 and oblong openings 32. The oblong openings 32 have a larger surface area in the plane perpendicular to the opening axis than the circular openings 31. Moreover, the dimension of the oblong openings 32 in the direction perpendicular to the longitudinal direction X of the mounting profile is greater than the diameter of the circular openings 31. In the outer row 1 of openings circular openings 11 are equally spaced along the profile. The circular openings 11 of the outer rows 1, located on the same side wall W, are offset from each other in the longitudinal direction of the profile by a value equal to half the space between the circular openings 11. Likewise, the circular openings 11 of the opposite outer rows 1, positioned on the opposite side walls W, are also offset from each other in the longitudinal direction of the profile by a value equal to half the space between the circular openings. The circular openings 11 in the outer row 1 of openings and the circular openings 31 in the inner row 3 of openings are openings for self-tapping screws.

**[0069]** A seventh embodiment of a mounting profile according to the invention is shown in figures 13 and 14. The mounting profile is formed of a longitudinal closed profile with a

hexagonal cross-section having a longitudinal direction X extending parallel to the longitudinal edges of the profile.

**[0070]** The closed profile comprises six side walls W.

**[0071]** A seventh embodiment of the invention includes two fastening assemblies, one on each of the opposing side walls W.

**[0072]** The outer rows 1 of openings comprise circular openings 11, while the inner row 3 of openings comprises alternately placed circular openings 31 and oblong openings 32. The oblong openings 32 have a larger surface area in the plane perpendicular to the opening axis than the circular openings 31. Moreover, the dimension of the oblong openings 32 in the direction perpendicular to the longitudinal direction X of the mounting profile is greater than the diameter of the circular openings 31. In the outer row 1 of openings circular openings 11 are equally spaced along the profile. The openings of the outer rows 1, positioned on the same side wall W, are offset from each other in the longitudinal direction of the profile by a value equal to half the space between the circular openings 11. The circular openings 11 of the opposite outer rows 1, positioned on the opposite side walls W, are also offset from each other in the longitudinal direction by a value equal to half the space between the circular openings 11. The circular openings 11 in the outer row 1 of openings and the circular openings 31 in the inner row 3 of openings are openings for self-tapping screws.

**[0073]** On the remaining side walls W the mounting profile according to the present embodiment comprises additional longitudinally extending rows 4 of circular openings 41. The directions in which the additional rows 4 extend are consistent with the longitudinal direction X.

**[0074]** Additional rows 4 of openings are positioned in the middle of the width of the side walls W.

**[0075]** The circular openings 41 are equally spaced along the profile. The circular openings 41, positioned in additional rows 4 of openings on the adjacent side walls W, are offset from each other in the longitudinal direction by a value equal to half the space between the circular openings 41. The circular openings 41, positioned in additional rows 4 of openings on the opposite side walls W, are not offset from each other. The circular openings 41, positioned in the additional row 4 of openings, are openings for self-tapping screws.

**[0076]** An eighth embodiment of a mounting profile according to the invention is shown in figures 15 and 16.

**[0077]** The mounting profile is formed of a longitudinal closed profile with a cross-section in the shape of regular hexagon having a longitudinal direction X extending parallel to the longitudinal edges of the profile.

**[0078]** The closed profile comprises six side walls W.

**[0079]** An eighth embodiment of the invention includes four fastening assemblies, one on each side wall W.

**[0080]** The outer rows 1 of openings include circular openings 11, while the inner row 3 of openings includes alternately placed circular openings 31 and oblong openings 32. The oblong openings 32 have a larger surface area in the plane perpendicular to the opening axis than the circular openings 31. Moreover, the dimension of the oblong openings 32 in the direction perpendicular to the longitudinal direction X of the mounting profile is greater than the diameter of the circular openings 31. In the outer row 1 of openings circular openings 11 are equally spaced along the profile. The circular openings 11 of the outer rows 1, positioned on the same side wall W, are offset from each other in the longitudinal direction of the profile by a value equal to half the space between the circular openings 11. Likewise, the circular openings 11 of the opposite outer rows 1, positioned on the opposite side walls W, are also offset from each other in the longitudinal direction of the profile by a value equal to half the space between the circular openings 11. The circular openings 11, positioned in the outer row 1 of openings, and the circular openings 31, positioned in the inner row 3 of openings, are openings for self-tapping screws.

**[0081]** A ninth embodiment of a mounting profile according to the invention is shown in figures 17 and 18. The mounting profile is formed of a longitudinal closed profile with an octagonal cross-section having a longitudinal direction X extending parallel to the longitudinal edges of the profile.

**[0082]** The closed profile comprises eight side walls W.

**[0083]** A ninth embodiment of the invention includes four fastening assemblies, one on each side wall W, constituting two pairs of parallel side walls W.

**[0084]** The outer rows 1 of openings include circular openings 11, while the inner row 3 of openings includes alternately placed circular openings 31 and oblong openings 32. The oblong openings 32 have a larger surface area in the plane perpendicular to the opening axis than the circular openings 31. Moreover, the dimension of the oblong openings 32 in the direction perpendicular to the longitudinal direction X of the mounting profile is greater than the diameter of the circular openings 31. In the outer row 1 of openings circular openings 11 are equally spaced along the profile. The circular openings 11 of the outer rows 1 are offset from each other in the longitudinal direction of the profile by a value equal to half the space between the circular openings 11. The circular openings 11, positioned in the outer row 1 of openings, and the circular openings 31, positioned in the inner row 3 of openings, are openings for self-tapping screws.

**[0085]** On the remaining side walls W the mounting profile according to the present embodiment comprises additional longitudinally extending rows 4 of circular openings 41. The directions in which the additional rows 4 extend are consistent with the longitudinal direction X.

**[0086]** Additional rows 4 of openings are positioned in the middle of the width of the side walls W.

**[0087]** The circular openings 41 are equally spaced along the profile. The circular openings 41, positioned on the opposite side walls W, are offset from each other by a value equal to half the space between the circular openings 41. The circular openings 41, positioned in the additional row 4 of openings, are openings for self-tapping screws.

**[0088]** A tenth embodiment of a mounting profile according to the invention is shown in figures 19 and 20. The mounting profile is formed of a longitudinal closed profile with a cross-section in the shape of a regular octagon having a longitudinal direction X extending parallel to the longitudinal edges of the profile.

**[0089]** The closed profile comprises eight side walls W.

**[0090]** A tenth embodiment of the invention includes eight fastening assemblies, one on each side wall W.

**[0091]** The outer rows 1 of openings include circular openings 11, while the inner row 3 of openings includes alternately placed circular openings 31 and oblong openings 32. The oblong openings 32 have a larger surface area in the plane perpendicular to the opening axis than the circular openings 31. Moreover, the dimension of the oblong openings 32 in the direction perpendicular to the longitudinal direction X of the mounting profile is greater than the diameter of the circular openings 31. In the outer row 1 of openings circular openings 11 are equally spaced along the profile. The circular openings 11 of the outer rows 1, positioned on the same side wall W, are offset from each other in the longitudinal direction of the profile by a value equal to half the space between the circular openings 11. Likewise, the circular openings 11 of the opposite outer rows 1, positioned on the opposite side walls W, are also offset from each other in the longitudinal direction of the profile by a value equal to half the space between the circular openings 11. The circular openings 11, positioned in the outer row 1 of openings, and the circular openings 31, positioned in the inner row 3 of openings, are openings for self-tapping screws.

### **Industrial Applicability**

**[0092]** The solution according to the present invention is used in construction, in particular in pipeline support installations, in a wide range of loads, for industry for fastening technological installations, as support structures with a large span of beams for various types of exchangers, fans, air conditioners, as independent building structures or their components, for building vertical and horizontal platforms and pedestrian paths, and also for outdoor applications.

**[0093]** The invention according to the second and third embodiment has a particularly

advantageous application as a light-load bearing profile, a profile for mounting sprinkler systems, fire protection installations, as a strut, bracing, stiffening, for large spans of the structure, high supports but low loads, for mounting advertising on roofs and facades. It is also planned to use in mounting ventilated facades as an element of the supporting structure.

**[0094]** The invention according to the fourth and fifth embodiment is particularly advantageous as a profile for heavy-duty loadbearing structures, in heavy industry installations, as a structural profile for noise barriers, as a structural profile for the construction of small flyovers for e.g. pipelines. Due to long life, non-flammability and good protection against fungi and insects, it is also intended to be used as a structural profile for custom-made houses with an area of less than 35 m<sup>2</sup>.

**[0095]** The invention according to the eighth embodiment has a particularly advantageous application in the case of three-dimensional structures with a horizontal projection in the shape of a cuboid and an angle of 60 degrees as a structural column, trellis trusses with a triangular cross-section and for mounting installations in the corners of industrial halls.

**[0096]** The invention according to the ninth embodiment has a particularly advantageous application in the case of three-dimensional structures with a rectangular plan view as a structural column and when high stiffness of high structures is required.

**[0097]** The invention according to the tenth embodiment has a particularly advantageous application in the case of three-dimensional structures with a rectangular plan view and an angle of 45 degrees as a structural column.

## **REFERENCES CITED IN THE DESCRIPTION**

Cited references

This list of references cited by the applicant is for the reader's convenience only. It does not form part of the European patent document. Even though great care has been taken in compiling the references, errors or omissions cannot be excluded and the EPO disclaims all liability in this regard.

**Patent documents cited in the description**

- [EP1640524A2 \[0002\]](#)

**Patentkrav**

1. Monteringsprofil, som er dannet af et langsgående lukket profil med et polygonalt tværsnit og har mindst fire sidevægge (W), omfattende på mindst én  
5 sidevæg (W) en fastgørelsesanordning, der inkluderer to i længderetningen løbende ydre rækker (1) af åbninger, som er placeret ved de langsgående kanter af sidevæggen (W), mindst en i længderetningen løbende indre række (3) af  
10 åbninger og mindst to i længderetningen løbende prægninger (2) rettet indad i profilet, **kendetegnet ved, at** prægningerne (2) er placeret mellem de ydre rækker (1) af åbninger og den indre række (3) af åbninger.

2. Profil ifølge krav 1, **kendetegnet ved, at** den ydre række (1) af åbninger inkluderer cirkulære åbninger (11), og den indre række (3) af åbninger inkluderer cirkulære åbninger (31) og aflange åbninger (32).

15

3. Profil ifølge krav 2, **kendetegnet ved, at** de cirkulære åbninger (31) og de aflange åbninger (32) i den indre række (3) af åbninger er arrangeret skiftevis.

4. Profilet ifølge krav 2 eller 3, **kendetegnet ved, at** de aflange åbninger (32) i  
20 den indre række (3) af åbninger har et større overfladeareal i planet vinkelret på åbningsaksen end de cirkulære åbninger (31).

5. Monteringsprofil ifølge krav 2, **kendetegnet ved, at** de cirkulære åbninger (11) i den indre række (1) af åbninger er ligeligt fordelt langs profilets længde.

25

6. Monteringsprofil ifølge krav 5, **kendetegnet ved, at** de cirkulære åbninger (11) af de ydre rækker (1) af åbninger anbragt på samme sidevæg (W) er forskudt i forhold til hinanden i profilets længderetning med en værdi svarende til halvdelen af mellemrummet mellem de cirkulære åbninger (11).

30

7. Monteringsprofil ifølge et hvilket som helst af kravene 2 til 6, **kendetegnet ved, at** de cirkulære åbninger (11) af den ydre række (1) af åbninger og de cirkulære åbninger (31) af den indre række (3) af åbninger er åbninger til selvskærende skruer.

35

- 8.** Monteringsprofil ifølge et hvilket som helst af kravene 1 til 7, **kendetegnet ved, at** de ydre rækker (1) af åbninger i fastgørelsesanordningen er placeret symmetrisk i forhold til den indre række (3) af åbninger.
- 5 **9.** Monteringsprofil ifølge et hvilket som helst af kravene 1 til 8, **kendetegnet ved, at** prægningerne (2) er placeret symmetrisk i forhold til den indre række (3) af åbninger.
- 10.** Monteringsprofil ifølge krav 1, **kendetegnet ved, at** det er dannet af et
- 10 langsgående lukket profil med et trapezformet tværsnit.
- 11.** Monteringsprofil ifølge krav 1, **kendetegnet ved, at** det er dannet af et langsgående lukket profil med et rektangulært tværsnit.
- 15 **12.** Monteringsprofil ifølge krav 1, **kendetegnet ved, at** det er dannet af et langsgående lukket profil med et kvadratisk tværsnit.
- 13.** Monteringsprofil ifølge krav 10, **kendetegnet ved, at** det omfatter en fastgørelsesanordning dannet på en sidevæg (W), der er forbundet med den
- 20 længere bund af trapezet.
- 14.** Monteringsprofil ifølge krav 11, **kendetegnet ved, at** det omfatter to fastgørelsesanordninger, en på hver af de to modstående sidevægge (W).
- 25 **15.** Monteringsprofil ifølge krav 14, **kendetegnet ved, at** fastgørelsesanordningerne er dannet på sidevægge (W), der udgør de kortere sider af det rektangulære tværsnit.
- 16.** Monteringsprofil ifølge krav 14, **kendetegnet ved, at** fastgørelses-
- 30 anordningerne er dannet på sidevægge (W), der udgør de længere sider af det rektangulære tværsnit.
- 17.** Monteringsprofil ifølge krav 12, **kendetegnet ved, at** det omfatter fire fastgørelsesanordninger, en på hver af sidevæggene (W).

**18.** Monteringsprofil ifølge krav 1, **kendetegnet ved, at** det er dannet af et langsgående lukket profil med et sekskantet tværsnit.

**19.** Monteringsprofil ifølge krav 18, **kendetegnet ved, at** det omfatter to fastgørelsesanordninger, en på hver af de to modstående sidevægge (W).

**20.** Monteringsprofil ifølge krav 18, **kendetegnet ved, at** sekskanten er en regulær sekskant.

**21.** Monteringsprofil ifølge krav 20, **kendetegnet ved, at** det består af seks fastgørelsesanordninger, en på hver af sidevægge (W).

**22.** Monteringsprofil ifølge krav 1, **kendetegnet ved, at** det er dannet af et langsgående lukket profil med et ottekantet tværsnit.

15

**23.** Monteringsprofil ifølge krav 22, **kendetegnet ved, at** det omfatter fire fastgørelsesanordninger, en på hver af sidevæggene (W), der danner to par af modstående sidevægge (W).

**24.** Monteringsprofil ifølge krav 22, **kendetegnet ved, at** ottekanten er en regulær ottekant.

**25.** Monteringsprofil ifølge krav 24, **kendetegnet ved, at** den omfatter otte fastgørelsesanordninger, en på hver af sidevæggene (W).

25

# DRAWINGS

Drawing

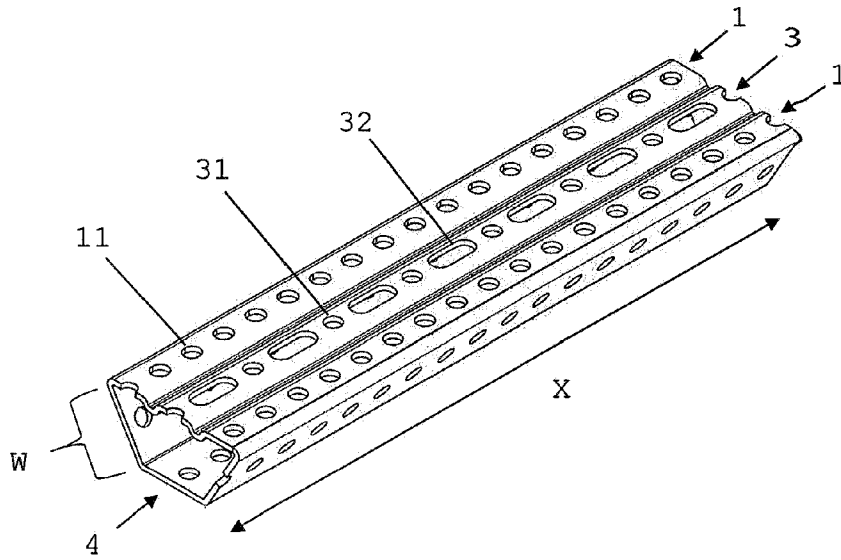

Fig. 1

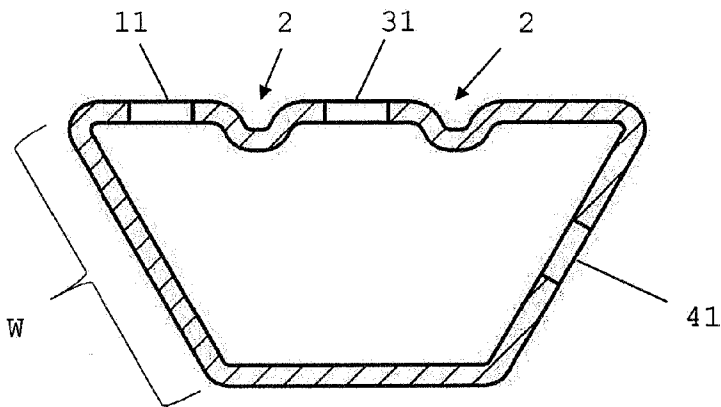

Fig. 2

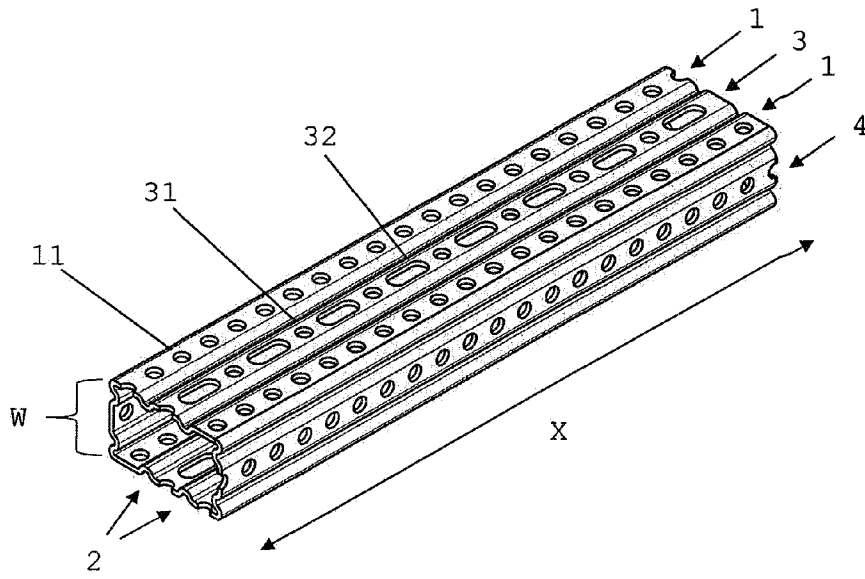

Fig. 3

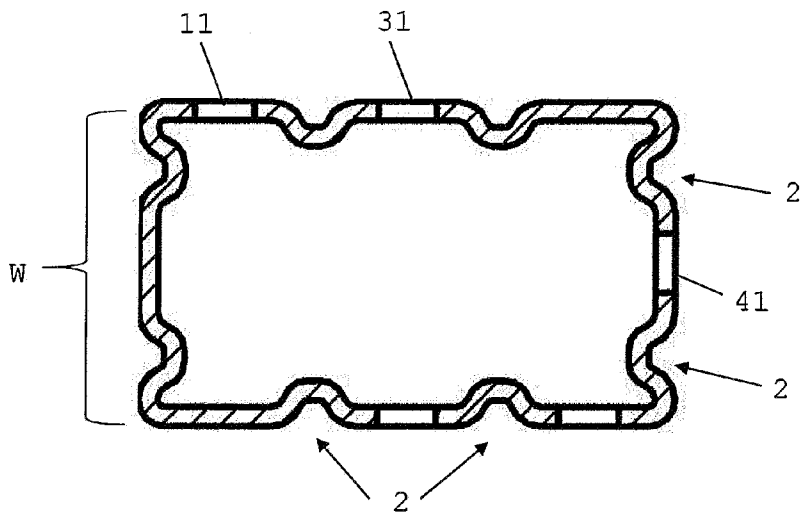

Fig. 4

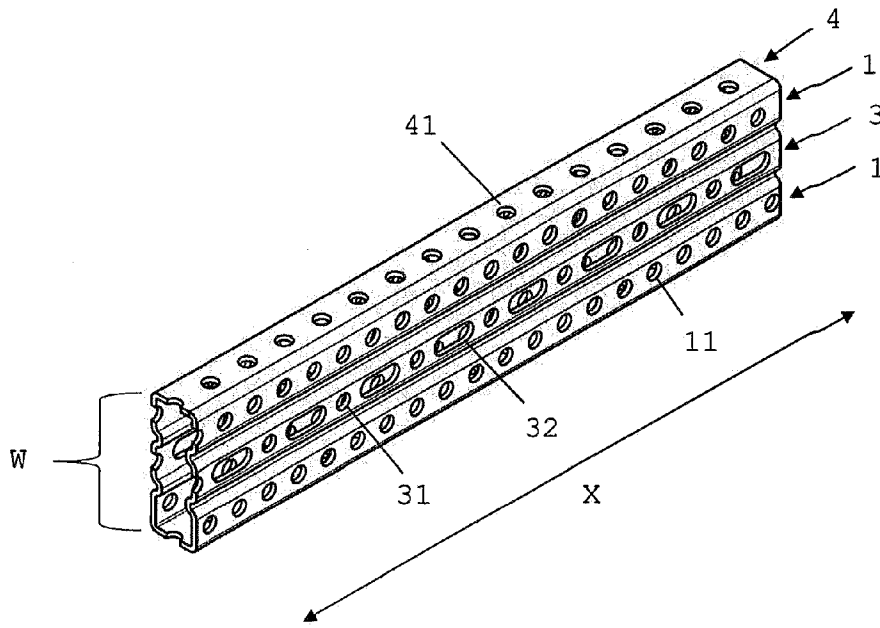

Fig. 5

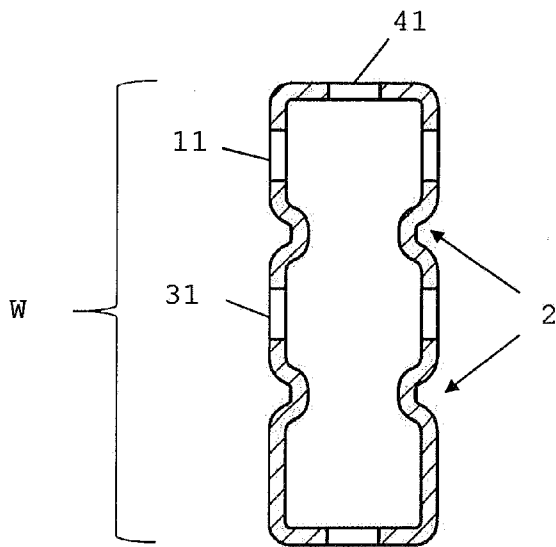

Fig. 6

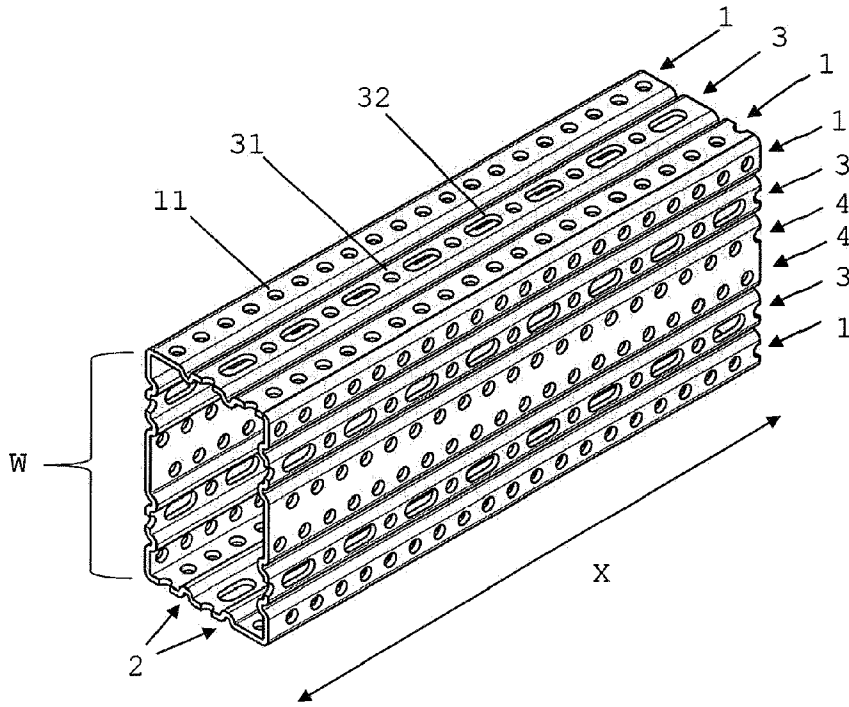

Fig. 7

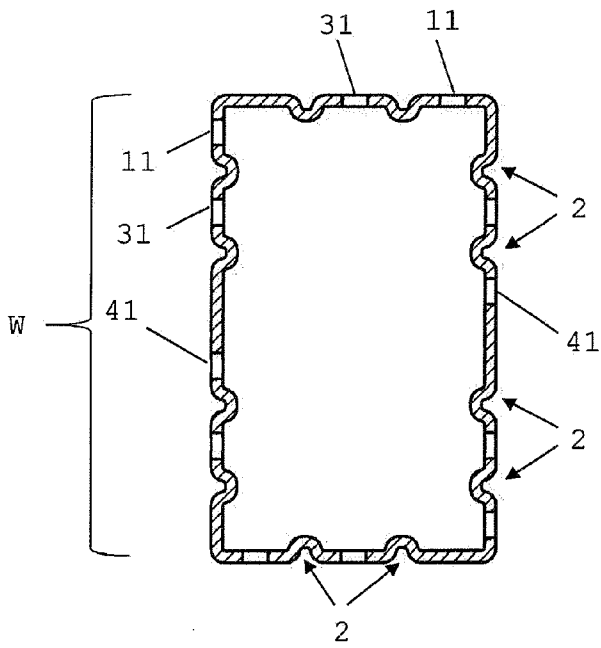

Fig. 8

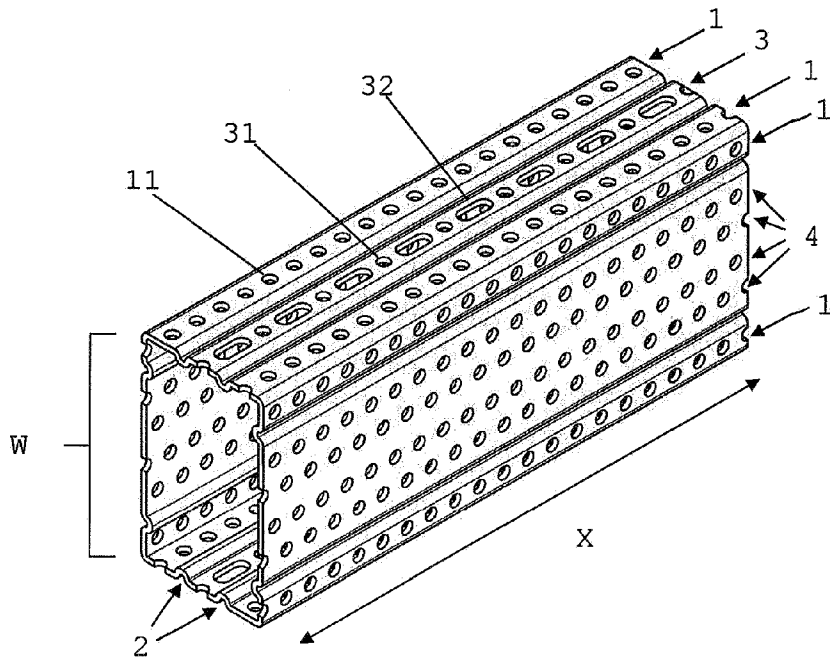

Fig. 9

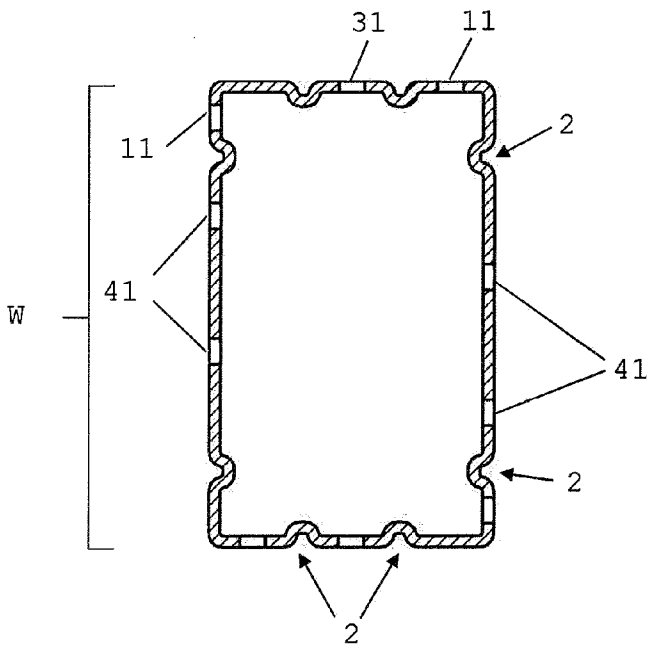

Fig. 10

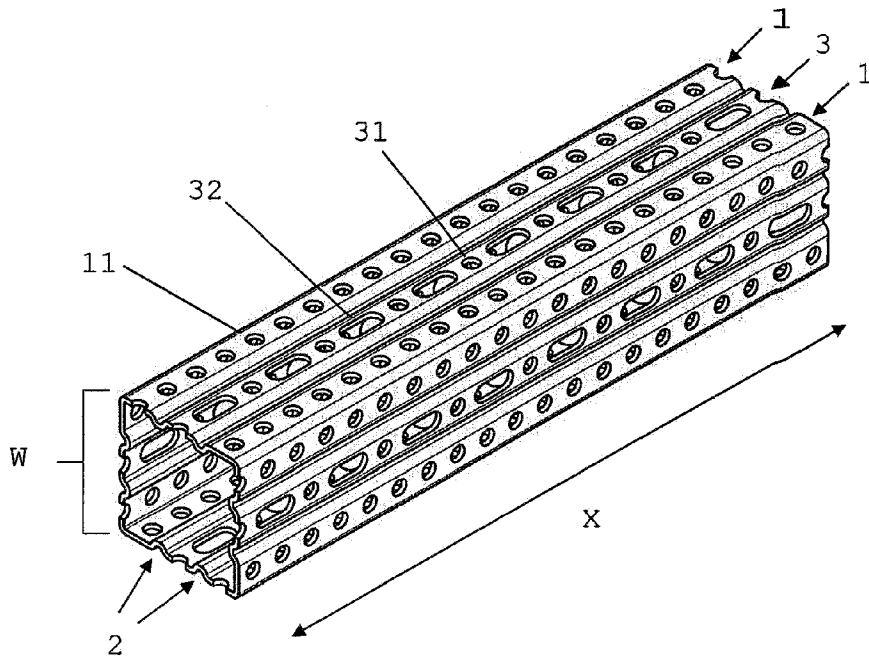

Fig. 11

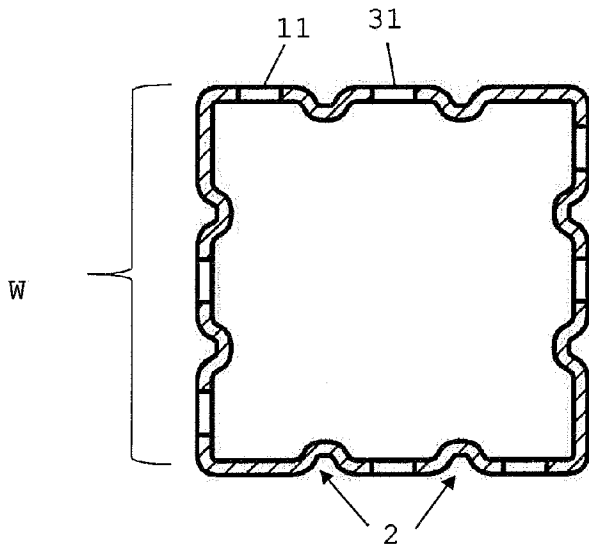

Fig. 12

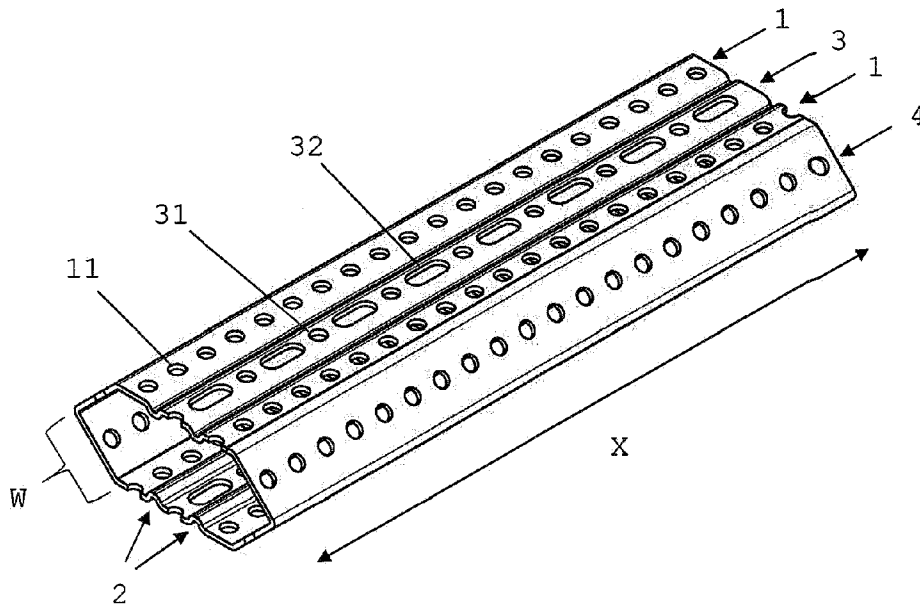

Fig. 13

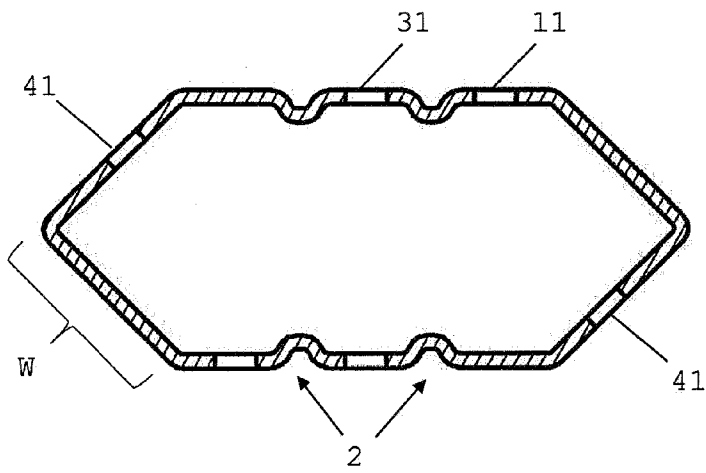

Fig. 14

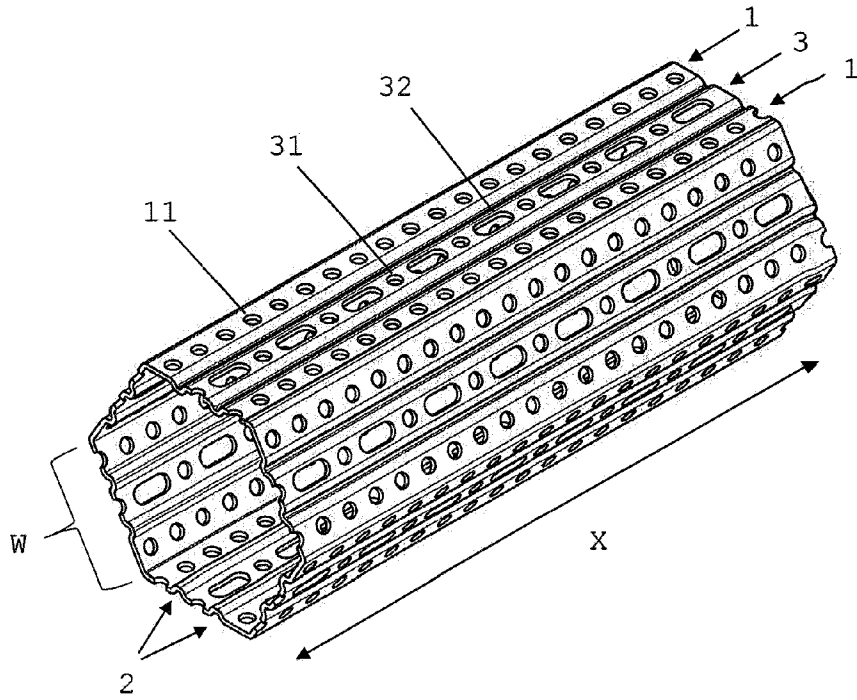

Fig. 15

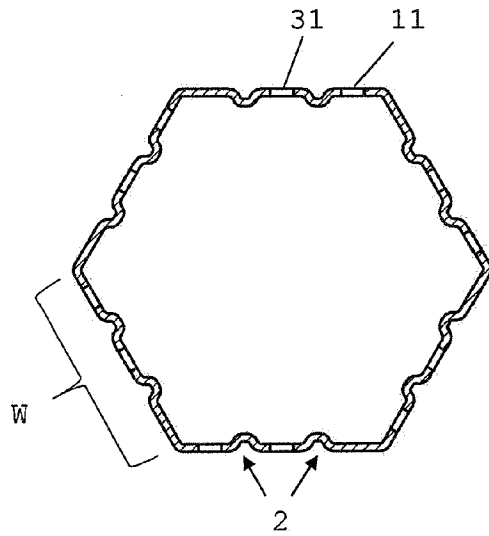

Fig. 16

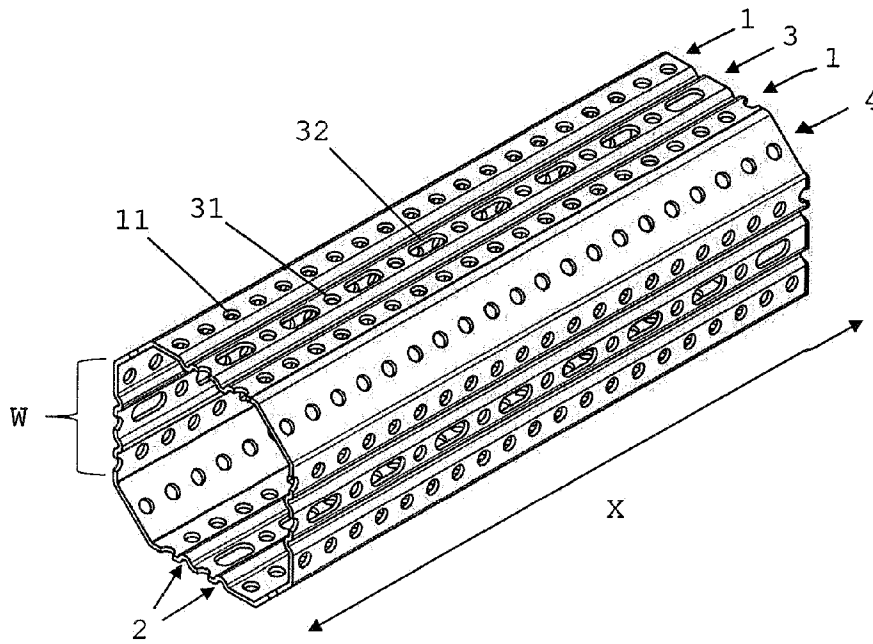

Fig. 17

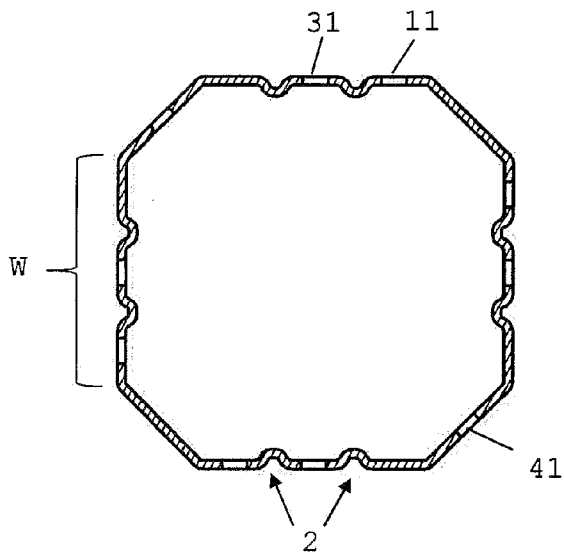

Fig. 18

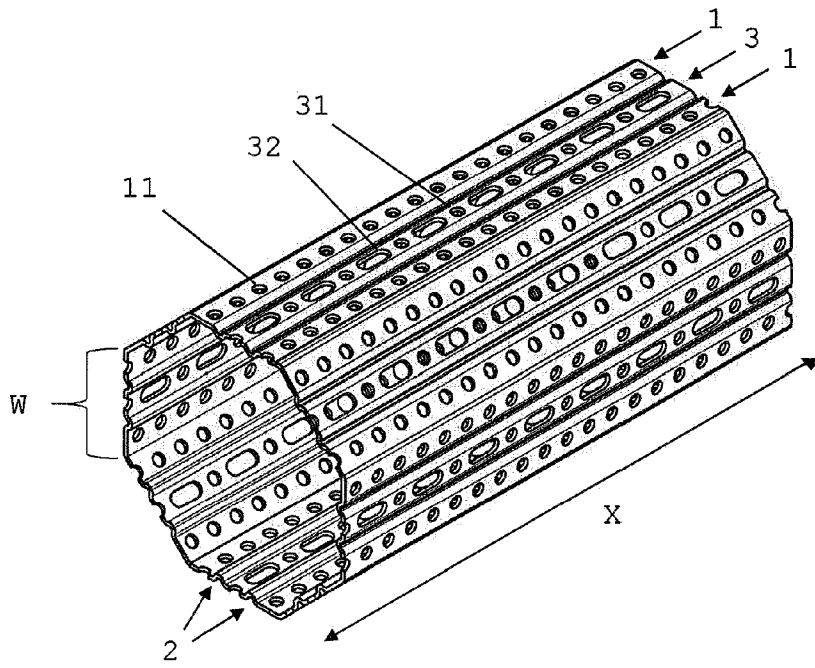

Fig. 19

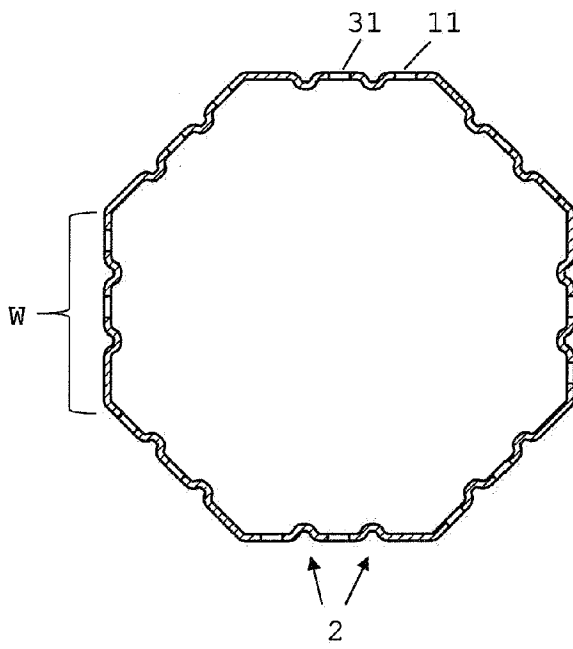

Fig. 20