



- (51) International Patent Classification:
B44C 1/165 (2006.01) *B44C 3/02* (2006.01)
- (21) International Application Number:
PCT/US2012/059648
- (22) International Filing Date:
11 October 2012 (11.10.2012)
- (25) Filing Language: English
- (26) Publication Language: English
- (30) Priority Data:
2012-112454 16 May 2012 (16.05.2012) JP
- (71) Applicant: **3M INNOVATIVE PROPERTIES COMPANY** [US/US]; 3M Center, Post Office Box 33427, Saint Paul, Minnesota 55133-3427 (US).
- (72) Inventors; and
(71) Applicants (*for US only*): **YAMAMOTO, Tanaka** [JP/JP]; 33-1, Tamagawadai 2-chome, Setagaya, Tokyo 158-8583 (JP). **ABE, Hidetoshi** [JP/JP]; 33-1, Tamagawadai 2-chome, Setagaya, Tokyo 158-8583 (JP).
- (74) Agents: **BLANK, Colene H.**, et al.; 3M Center Office of Intellectual Property Counsel, Post Office Box 33427, Saint Paul, Minnesota 55133-3427 (US).

- (81) Designated States (*unless otherwise indicated, for every kind of national protection available*): AE, AG, AL, AM, AO, AT, AU, AZ, BA, BB, BG, BH, BN, BR, BW, BY, BZ, CA, CH, CL, CN, CO, CR, CU, CZ, DE, DK, DM, DO, DZ, EC, EE, EG, ES, FI, GB, GD, GE, GH, GM, GT, HN, HR, HU, ID, IL, IN, IS, JP, KE, KG, KM, KN, KP, KR, KZ, LA, LC, LK, LR, LS, LT, LU, LY, MA, MD, ME, MG, MK, MN, MW, MX, MY, MZ, NA, NG, NI, NO, NZ, OM, PA, PE, PG, PH, PL, PT, QA, RO, RS, RU, RW, SC, SD, SE, SG, SK, SL, SM, ST, SV, SY, TH, TJ, TM, TN, TR, TT, TZ, UA, UG, US, UZ, VC, VN, ZA, ZM, ZW.
- (84) Designated States (*unless otherwise indicated, for every kind of regional protection available*): ARIPO (BW, GH, GM, KE, LR, LS, MW, MZ, NA, RW, SD, SL, SZ, TZ, UG, ZM, ZW), Eurasian (AM, AZ, BY, KG, KZ, RU, TJ, TM), European (AL, AT, BE, BG, CH, CY, CZ, DE, DK, EE, ES, FI, FR, GB, GR, HR, HU, IE, IS, IT, LT, LU, LV, MC, MK, MT, NL, NO, PL, PT, RO, RS, SE, SI, SK, SM, TR), OAPI (BF, BJ, CF, CG, CI, CM, GA, GN, GQ, GW, ML, MR, NE, SN, TD, TG).

Published:
— with international search report (Art. 21(3))

(54) Title: DECORATIVE SHEET

Fig. 1

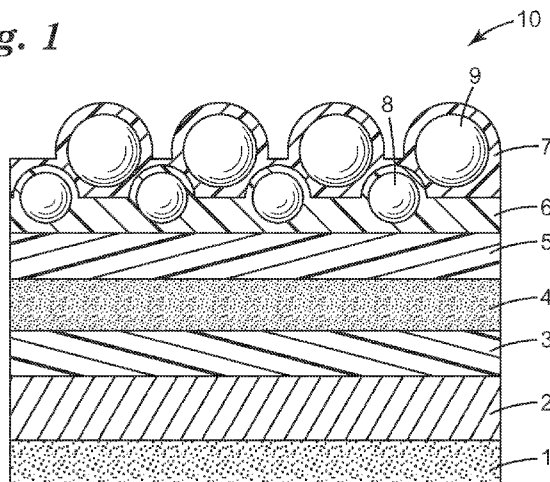

(57) Abstract: To provide a decorative sheet which has anti-skid properties, is resistant to abrasion, exhibits high abrasion resistance even when bonded to a floor or road surface over which pedestrians or vehicles traverse, does not cause pedestrians or vehicles to skid, and does not suffer from damage or peeling. [Resolution Means] A decorative sheet having a first bead coat layer comprising a resin and particles having a median diameter of from 20 μ m to 60 μ m, a second bead coat layer which is coated on the first bead coat layer and which includes a resin and particles having a median diameter of from 20 μ m to 60 μ m, a design layer and an adhesive layer.



DECORATIVE SHEET

FIELD OF THE INVENTION

[0001]

5 The present invention relates to a decorative sheet.

BACKGROUND

[0002]

10 Decorative sheets with colors, patterns or letters/characters are bonded to road surfaces or floors.

[0003]

15 For example, Japanese Unexamined Patent Application Publication No. S56-3707 discloses a pavement marking sheet material comprising a base sheet, a surface layer, and a single layer of particles which is partially embedded in the surface layer and partially exposed and which is supported by the surface layer.

[0004]

20 In addition, Japanese Unexamined Patent Application Publication No. 2001-295454 discloses an adhesive sheet which includes a base layer, a protective layer disposed on the surface of the base layer, and an adhesive layer disposed on the rear surface of the base layer, wherein the above protective layer contains a surface-modifying agent that modifies the surface of the protective layer, a curable resin, and inorganic oxide particles.

[0005]

25 This type of decorative sheet is bonded to indoor and outdoor floors or a surface of roads or parking lots in order to display information such as advertisements, direction indicators, traffic signs or directions, but because pedestrians and vehicles such as automobiles traverse the sheets bonded to floors, road surfaces and the like in this type of use, the surfaces of the decorative sheets tend to become damaged by abrasion or peel off. In particular, in cases where vehicles pass over decorative sheets or cases where vehicles make turns on decorative sheets, that is, cases where tires change direction on decorative sheets, the decorative sheets are readily damaged or peeled off.

30

SUMMARY OF THE INVENTION

Problem to be solved by the Invention

[0007]

35 An object of the present invention is to provide a decorative sheet which has anti-skid properties, is resistant to abrasion, exhibits high adhesion even when bonded to a floor or road surface, which is subjected to high temperature in summer, over which pedestrians or vehicles traverse, does not cause pedestrians or vehicles to skid, and does not suffer from damage or peeling.

Means to Solve the Problem

[0008]

Specifically, the present invention provides a decorative sheet including a first bead coat layer having a resin and particles having a median diameter of from 20 μm to 60 μm , a second bead coat layer which is laminated on the first bead coat layer and which comprises a resin and particles having a median diameter of from 20 μm to 60 μm , a design layer, and an adhesive layer.

EFFECT OF THE INVENTION

[0009]

According to the present invention, it is possible to provide a decorative sheet which has anti-skid properties, is resistant to abrasion, exhibits high adhesion even when bonded to a floor or road surface over which pedestrians or vehicles traverse, does not cause pedestrians or vehicles to skid, and does not suffer from damage or peeling even under high temperature.

15 BRIEF DESCRIPTION OF THE DRAWING

[0010]

FIG. 1 is a cross-sectional view of one example of a decorative sheet of the present invention.

20 DETAILED DESCRIPTION OF THE INVENTION

[0011]

A decorative sheet of the present invention has a first bead coat layer, a second bead coat layer, a design layer and an adhesive layer.

[0012]

The second bead coat layer is coated on the first bead coat layer and is positioned at the outermost layer of the decorative sheet.

[0013]

The first and second bead coat layers each contain a resin and particles having a median diameter of from 20 μm to 60 μm .

30 [0014]

Here, "containing particles having a median diameter of from 20 μm to 60 μm " means that 50% of the particles contained in the bead coat layers have a specific particle diameter that falls within the range from 20 μm to 60 μm . Median means the central value in the particle diameter distribution of the particles contained in the bead coat layers, and is expressed as "D50" in the present specification.

[0015]

In addition, the bead coat layers may contain two or more types of particles having different particle diameters. For example, a case in which "particles having a median diameter of 30 μm and

particles having a median diameter of 50 μm are contained at a mass ratio of 8:2" means that 80% of the particles contained in the bead coat layer have a median diameter of 30 μm and 20% of the particles contained in the bead coat layer have a median diameter of 50 μm .

[0016]

5 The median diameters of the particles contained in the first bead coat layer and the second bead coat layer may be the same or different. In cases where these median diameters are different, the median diameter of the particles contained in the second bead coat layer may be greater than the median diameter of the particles contained in the first bead coat layer, or the median diameter of the particles contained in the second bead coat layer may be less than the median diameter of the particles contained in the first bead coat layer.

[0017]

The combination of the median diameters of the particles contained in the first and second bead coat layers can be selected as appropriate and is not limited.

[0018]

15 The particles are almost spherical particles comprising an inorganic or organic material, and are preferably non-tacky particles. Specifically, it is possible to use particles comprising, for example, alumina, silica, glass, another metal oxide, a polyester resin, a polystyrene resin, an acrylic resin or a urethane resin. In cases where particles comprising a resin are used, the particles are preferably crosslinked from the perspective of solvent resistance.

20 [0019]

The resins contained in the first and second bead coat layers are not particularly limited as long as these resins are resins that do not exhibit tacky adhesive properties. It is preferable to use a resin which has good particle wettability and which has excellent film strength and solvent resistance. In addition, it is preferable to use a crosslinkable resin from the perspective of solvent resistance.

25 Specifically, it is possible to use, for example, a urethane resin, an acrylic resin, a vinyl chloride resin, a silicone resin, an epoxy resin, a fluororesin, a melamine resin, and an alkyd resin or a mixture thereof. The viscosity of the resin can be from approximately 100 to approximately 5,000 centipoise.

[0020]

30 The mass ratio of the particles and the resin in the bead coat layers is not particularly limited, but can be, for example, from approximately 8:2 to approximately 1:9.

[0021]

The first bead coat layer can be obtained by, after adding the particles to the resin and blending, coating on the surface of the transparent film layer or the design layer by using a conventional publicly known method such as knife coating, and then drying.

35 [0022]

The second bead coat layer can be obtained by, after adding the particles to the resin and blending, coating on the surface of the already prepared first bead coat layer by using a conventional publicly known method such as knife coating, and then drying.

[0023]

In the present invention, the first bead coat layer and the second bead coat layer must be formed independently as separate layers.

[0024]

5 The thickness of the first bead coat layer and the second bead coat layer is not particularly limited. For example, the thickness of the first bead coat layer and the second bead coat layer can be from approximately 10 μm to approximately 100 μm and approximately from 20 μm to approximately 80 μm respectively.

[0025]

10 Furthermore, it is preferable for the particles not to be exposed from the resin and for the surface of the layers to be covered by the resin in the first bead coat layer and the second bead coat layer.

[0026]

15 The coating weights of the first bead coat layer and the second bead coat layer are not particularly limited, but can be from approximately 10 g/m^2 to approximately 50 g/m^2 .

[0027]

The decorative sheet of the present invention contains a design layer. The design layer is constituted from a printed layer that is provided on a transparent film that is an optional constituent element or from a colored film obtained by coloring a plastic.

20 [0028]

In cases where the design layer is a printed layer, the printed layer is provided on a transparent film layer by means of inkjet printing using a water-based ink, an organic solvent-based ink or a UV ink, silk screen printing, gravure printing, electrostatic printing, offset printing and the like.

25 [0029]

The decorative sheet of the present invention contains a transparent film layer as an optional constituent element. The transparent film layer is a base material for the design layer. A film having sufficient strength (toughness) to fulfill the above mentioned role or a resin layer obtained by coating a resin on the surface of the design layer and then drying can be used as this type of transparent film layer.

30

[0030]

This type of film can be a film comprising, for example, an acrylic polymer, a urethane-based polymer, a polyester such as polyethylene terephthalate (PET), poly(vinyl chloride), a polyolefin such as polyethylene or polypropylene (PP) or a fluorinated polymer. Of these, acrylic polymers are preferably used from the perspective of printability.

35

[0031]

The thickness of the transparent film layer can be selected as appropriate, and is not limited. For example, this thickness can be from approximately 3 μm to approximately 500 μm or from

approximately 5 μm to approximately 300 μm .

[0032]

The decorative sheet may further contain a bonding layer as an optional constituent element. The bonding layer fulfills the role of bonding the two layers adjacent thereto and also imparts opacity.

5 The bonding layer contains an adhesive comprising a conventional publicly known tacky adhesive polymer, such as an acrylic-based, rubber-based, urethane-based, polyester-based or silicone-based polymer. In cases where the bonding layer imparts opacity, it is possible to use a colored adhesive obtained by further adding a publicly known dye or pigment to these tacky adhesives. It is possible to use, for example, titanium oxide as a pigment. In this case, the colored adhesive will be white. By
10 using a colored adhesive having a suitable opacity as the bonding layer, differences in color density in the design layer do not occur and it is possible to provide a sharper design.

[0033]

The thickness of the bonding layer can be selected as appropriate, and is not limited. For example, this thickness can be from approximately 5 μm to approximately 200 μm or from
15 approximately 10 μm to approximately 100 μm .

[0034]

The decorative sheet may further contain a metal layer of aluminum, an aluminum alloy and the like as an optional constituent element. The metal layer imparts the decorative sheet with toughness and improves followability to uneven surfaces.

20 [0035]

The thickness of the metal layer can be selected as appropriate, and is not limited. For example, this thickness can be from approximately 20 μm to approximately 200 μm .

[0036]

25 The decorative sheet has an adhesive layer in order to bond the decorative sheet to an adherend such as a floor or road surface. The adhesive layer contains an adhesive (a pressure-sensitive adhesive) comprising a conventional publicly known adhesive polymer, such as an acrylic-based, urethane-based, polyester-based, rubber-based or silicone-based polymer. Those adhesive polymer may be crosslinked with known cross linking agents. Preferred adhesive polymer may be crosslinked acrylic-based polymer or rubber-based polymer.

30 The surface of the adhesive layer may be treated by electron beam (ebeam) to improve adhesion to the adherend. When using rubber

-based adhesive, the adhesion especially under high temperature such as 65 $^{\circ}\text{C}$ can be improved by ebeam treatment. Irradiance level of ebeam is not limited but may be from about 0.5 Mrad to about 10 Mrad or about 1 Mrad to about 6 Mrad.

35

[0037]

The thickness of the adhesive layer is not particularly limited, but can be, for example, from approximately 10 μm to approximately 200 μm , from approximately 20 μm to approximately 150 μm ,

or from approximately 30 μm to approximately 100 μm .

[0038]

The decorative sheet can be obtained by laminating an adhesive layer, a metal layer, a bonding layer, a design layer, a transparent film layer, a first bead coat layer and a second bead coat layer in that order. Furthermore, the decorative sheet may, if necessary, also have a layer having a different function, such as a primer layer. The adhesive layer and the second bead coat layer are the outermost layers, with the adhesive layer being on the adherend side and the second bead coat layer being on the opposite side thereto.

[0039]

In addition, the decorative sheet may be provided with a liner (a release layer) on the outer side of the adhesive layer. This type of liner may be liners often used in fields of tacky adhesive tapes and the like, and is not limited to the specified components. Preferred liners include paper, plastic materials such as polyethylene, polypropylene, polyesters or cellulose acetate, paper that is covered or laminated with this type of plastic material, or other materials. These liners may be used without further modification, but can be used after being subjected to silicone treatment or treated using another method in order to improve the release properties thereof.

[0040]

The decorative sheet can be produced by appropriately selecting a conventional publicly known method. An example of a production method is given below.

[0041]

A transparent film layer is formed by coating a resin that constitutes the transparent film layer on a plastic film liner such as a polyester film by means of knife coating and the like and then drying.

[0042]

A bead coat layer 1 is formed by coating a particle-containing resin solution that constitutes the bead coat layer 1 on the surface of the obtained transparent film layer that is opposite the liner, and then drying. A bead coat layer 2 is then formed by coating a particle-containing resin solution that constitutes the bead coat layer 2 on the bead coat layer 1 and then drying.

[0043]

The liner is peeled from the transparent film layer, and a design layer is formed by printing on the surface of the transparent film layer by using an inkjet printer and the like.

[0044]

A decorative sheet is then obtained by bonding an aluminum foil having an adhesive on both surfaces thereof (a film obtained by laminating white tacky adhesive/aluminum foil/acrylic or rubber tacky adhesive/liner) to the design layer.

[0045]

The decorative sheet can be bonded to an indoor or outdoor floor or a road surface such as a road or parking lot so as to display information such as advertisements, direction indicators, traffic

signs or directions.

[0046]

The following abbreviations are used in the present specification.

BA: n-butyl acrylate

5 MEK: methyl ethyl ketone

AA: acrylic acid

MMA: methyl methacrylate

BMA: butyl methacrylate

DMAEMA: dimethyl aminoethyl methacrylate

10 IPA: Isopropyl alcohol

Examples

[0047]

15 Example 1

Sample preparation

[0048]

The sample of Example 1 was prepared as follows. The materials used are as shown in Table 1.

20

Step 1: Preparation of image-receiving film (transparent film layer)

[0049]

A mixed solution of P1, P2 and CL1 (see Table 1 for composition) was mixed with a mixer (TK Autohomomixer manufactured by Tokushu Kika Kogyo Co., Ltd.). The blending ratio of P1, P2 and CL1 was 100:75:0.15 in terms of solid content. The agitated solution was coated on a polyester film having a thickness of 50 μm by using a knife coater and then dried for 5 minutes at 95°C and 2 minutes at 155°C. Following the drying, an image-receiving film having a thickness of 50 μm (excluding the polyester film) was obtained.

30 Step 2: Coating of bead coat layer 1

[0050]

A mixed solution of PU1, CL2, Beads 1 and FA1 (see Table 1 for composition) was mixed with a mixer (TK Autohomomixer manufactured by Tokushu Kika Kogyo Co., Ltd.). The blending ratio of PU1, CL2, Beads 1 and FA1 was 30:5:35:0.69 in terms of solid content. The bead coat layer 1 was formed by coating the agitated solution on the image-receiving layer by using a knife coater and then drying for 2 minutes at 65°C, 3 minutes at 90°C, and 2 minutes at 155°C. Following the drying, the coating weight of the bead coat layer 1 was 37 g/m^2 .

Step 3: Coating of bead coat layer 2

[0051]

A mixed solution of PU1, CL2, Beads 2 and FA1 was mixed with a mixer (TK Autohomomixer manufactured by Tokushu Kika Kogyo Co., Ltd.). The blending ratio of PU1, CL2, Beads 2 and FA1 was 30:5:35:0.69 in terms of solid content. The bead coat layer 2 was formed by coating the agitated solution on the bead coat layer 1 by using a knife coater and then drying for 2 minutes at 65°C, 3 minutes at 90°C, and 2 minutes at 155°C. Following the drying, the coating weight of the bead coat layer 2 was 28 g/m².

Step 4: Printing of design layer

[0052]

The design layer was formed by peeling the polyester film of the image-receiving film, which includes the bead coat layer 1 and the bead coat layer 2, and printing on the surface of the image-receiving film by using a solvent inkjet printer (SC540 manufactured by Roland DG Corporation).

Step 5: Bonding of aluminum foil having tacky adhesive on both surfaces thereof

[0053]

40 parts by mass of methyl isobutyl ketone (MIBK) was added to 10 parts by mass of an acrylic resin 1 (compositional ratio of methyl methacrylate (MMA)/butyl methacrylate (BMA)/dimethyl aminoethyl methacrylate (DMAEMA) = 60:34:6 (mass ratio); weight average molecular weight (Mw) = approximately 70,000; Tg = approximately 66°C; supplied as an ethyl acetate solution) and 50 parts by mass of titanium oxide (TiPure R960 produced by DuPont), and agitated for 10 minutes in a paint shaker (ARE250 manufactured by Thinky Corporation), so as to obtain a pigment premix solution.

[0054]

Next, an adhesive component obtained by adding 50 parts by mass of titanium oxide 1 and 10 parts by mass of the acrylic resin 1 to 100 parts by mass of an adhesive polymer 1 (compositional ratio of butyl acrylate (BA)/acrylic acid (AA) = 96:4 (mass ratio); Tg = approximately -50°C; Mw = approximately 580,000; supplied as an ethyl acetate/toluene solution) was blended with the obtained pigment premix, thereby preparing a white adhesive composition solution. 0.2 parts by mass (in terms of solid content) of a crosslinking agent 1 (bisamide type, 1,1'-isophthaloyl-bis(2-methylaziridine) was added to 100 parts by mass of the tacky adhesive polymer 1. Compatibility of the tacky adhesive and the pigment was good, and dispersion was easily achieved. A white adhesive layer was obtained by coating the obtained white adhesive composition solution on an aluminum foil having a thickness of 50 μm by using a knife coater so that the thickness of the coating layer after drying was 30 μm, and then heating for 5 minutes at 90°C, drying and crosslinking. The white adhesive was protected by bonding a silicon-treated polyester liner having a thickness of 25 μm.

[0055]

Next, an adhesive polymer 2 (acrylic tacky adhesive SK-Dyne 1429 F2 produced by Soken Chemical & Engineering Co., Ltd.) was coated on a polyethylene-laminated paper liner, which had been subjected to silicone treatment on both surfaces, so that the thickness of the coating layer after drying was 45 μm . Following the drying, an aluminum foil having an adhesive on both surfaces was prepared by bonding the obtained paper liner to the aluminum foil on the surface opposite the side on which the white adhesive layer was formed.

The liner was peeled from the white adhesive layer of the obtained aluminum foil having an adhesive on both surfaces, and the aluminum foil having an adhesive on both surfaces was laminated on the design layer.

Example 2

[0056]

Example 2 was prepared in the same manner as Example 1, except that the coating weight of the bead coat layer 2 was 33 g/m^2 .

Example 3

[0057]

Example 3 was prepared in the same manner as Example 1, except that the coating weight of the bead coat layer 2 was 37 g/m^2 .

Comparative Example 1

[0058]

Comparative Example 1 was prepared in the same manner as Example 1, except that the bead coat layer 2 was not provided.

Comparative Examples 2 to 5

Step 1: Preparation of image-receiving film

[0059]

An image-receiving layer was prepared in the same manner as in Example 1.

[0060]

Step 2: Coating of bead coat layer 1

[0061]

A mixed solution of PU1, CL2, Beads 1 and FA1 (see Table 1 for composition) was mixed with a mixer (TK Autohomomixer manufactured by Tokushu Kika Kogyo Co., Ltd.). The blending ratio of PU1, CL2, Beads 3 and FA1 was 30:5:35:0.69 in terms of solid content. The bead coat layer 1 was formed by coating the agitated solution on the image-receiving layer by using a knife coater and

then drying for 2 minutes at 65°C, 3 minutes at 90°C, and 2 minutes at 155°C. Following the drying, the coating weight of the bead coat layer 1 in Comparative Examples 2, 3, 4 and 5 was 74, 84, 88 and 96 g/m² respectively.

5 Step 3: Printing of design layer

[0062]

The design layer was formed by peeling the polyester film of the image-receiving film, which had the bead coat layer 1 and the bead coat layer 2, and printing on the surface of the image-receiving film using a solvent inkjet printer (SC540 manufactured by Roland DG Corporation).

10

Step 4: Bonding of aluminum foil having tacky adhesive on both surfaces thereof

[0063]

The liner was peeled from the white adhesive layer of an aluminum foil having an adhesive on both surfaces, which was prepared in the same manner as Step 5 in Example 1, and the aluminum foil having an adhesive on both surfaces was laminated on the design layer.

15

Example 4

[0064]

Example 4 was prepared in the same manner as Example 1, except that Beads 1 was used in the alumina beads in the bead coat layer 2 and the coating weight of the bead coat layer 2 was 38.7 g/m².

20

Example 5

[0065]

Example 5 was prepared in the same manner as Example 1, except that a mixture of Beads 1 and Beads 2 (blending ratio was Beads 1:Beads 2 = 8:2) was used in the alumina beads in the bead coat layer 2 and the coating weight of the bead coat layer 2 was 38.2 g/m².

25

Example 6

[0066]

Example 6 was prepared in the same manner as Example 1, except that a mixture of Beads 1 and Beads 2 (blending ratio was Beads 1:Beads 2 = 9:1) was used in the alumina beads in the bead coat layer 2 and the coating weight of the bead coat layer 2 was 39.6 g/m².

30

Example 7

[0067]

Example 7 was prepared in the same manner as Example 1, except that Beads 2 was used in the alumina beads in the bead coat layer 1, Beads 1 was used in the bead coat layer 2 and the coating

35

weights of the bead coat layer 1 and the bead coat layer 2 were 35 g/m² and 44 g/m² respectively.

Example 8

[0068]

- 5 Example 8 was prepared in the same manner as Example 1, except that Beads 1 was used in the alumina beads in the bead coat layer 1, Beads 4 was used in the bead coat layer 2 and the coating weights of the bead coat layer 1 and the bead coat layer 2 were 37 g/m² and 26 g/m² respectively.

Example 9

10 [0069]

Example 9 was prepared in the same manner as Example 8, except that the coating weight of the bead coat layer 2 was 33 g/m².

Comparative Examples 6 to 8

15 Step 1: Preparation of image-receiving film

[0070]

An image-receiving film was prepared in the same manner as in Example 1.

Step 2: Coating of bead coat layer 1

20 [0071]

- A mixed solution of PU1, CL2, Beads 2 and FA1 (see Table 1 for composition) was mixed with a mixer (TK Autohomomixer manufactured by Tokushu Kika Kogyo Co., Ltd.). The blending ratio of PU1, CL2, Beads 2 and FA1 was 30:5:35:0.69 in terms of solid content. The bead coat layer 1 was formed by coating the agitated solution on the image-receiving layer by using a knife coater and then drying for 2 minutes at 65°C, 3 minutes at 90°C, and 2 minutes at 155°C. Following the drying, the coating weight of the bead coat layer 1 in Comparative Examples 6, 7 and 8 was 80, 88 and 110 g/m² respectively.

Step 3: Printing of design layer

30 [0072]

The design layer was formed by peeling the polyester film of the image-receiving film, which has the bead coat layer 1 and the bead coat layer 2, and printing on the surface of the image-receiving film using a solvent inkjet printer (SC540 manufactured by Roland DG Corporation).

35 Step 4: Bonding of aluminum foil having tacky adhesive on both surfaces thereof

[0073]

The liner was peeled from the white adhesive layer of an aluminum foil having an adhesive on both surfaces, which was prepared in the same manner as Step 5 in Example 1, and the aluminum

foil having an adhesive on both surfaces was laminated on the design layer.

Comparative Example 9

[0074]

- 5 Comparative Example 9 was prepared in the same manner as Examples 6 to 8, except that a mixture of Beads 1 and Beads 2 (blending ratio was Beads 1:Beads 2 = 2:8) was used in the alumina beads in the bead coat layer 1 and the coating weight of the bead coat layer 1 was 27 g/m².

Comparative Example 10

10 [0075]

Comparative Example 10 was prepared in the same manner as Examples 6 to 8, except that a mixture of Beads 1 and Beads 2 (blending ratio was Beads 1:Beads 2 = 5:5) was used in the alumina beads in the bead coat layer 1 and the coating weight of the bead coat layer 1 was 25 g/m².

15 Comparative Example 11

[0076]

Comparative Example 11 was prepared in the same manner as Examples 6 to 8, except that a mixture of Beads 1 and Beads 2 (blending ratio was Beads 1:Beads 2 = 8:2) was used in the alumina beads in the bead coat layer 1 and the coating weight of the bead coat layer 1 was 33 g/m².

20

Test Method

Dry steering test

[0077]

- 25 A test piece cut to a size of 15 cm × 20 cm was bonded to asphalt. The front wheels of a passenger car weighing approximately 2 tons (a Toyota Alphard) were positioned on the test piece. With the car stationary, the steering wheel was turned to the right so as to turn the tires as far as possible to the right. The steering wheel was then returned to the central position so that the tires were again parallel to the car. With this procedure constituting 1 cycle, the cycle was then carried out again in the same manner, but with the tires turned to the left instead of to the right, and then again
- 30 with the tires turned to the right, making for a total of 3 cycles. A case in which no tearing or peeling of the film occurred was deemed to be a pass, and a case in which tearing or peeling of the film occurred was deemed to be a fail, and the results are shown in Table 2.

Abrasion resistance test

35 [0078]

The liner was peeled from a sample cut to a size of 10 mm (width) × 10 mm (length), the sample was bonded to an aluminum plate, and a premask was peeled off. The abrasion resistance was evaluated in accordance with JIS A 1453. Using S-42 type sandpaper, cleaning the roller with a brush

every 100 revolutions and replacing the sandpaper every 500 revolutions, the white adhesive layer was abraded, and the number of revolutions until the white color of the graphic film disappeared was measured. The results are given in table 2.

5 Skid resistance test

[0079]

The liner was peeled from a sample, the sample was bonded to asphalt, and a premask was peeled off. Wet skid resistance was measured in accordance with ASTM E303-83. The results are given in table 2. A higher B.P.N. (British Pendulum Number) value indicates less skidding.

10

Adhesion test

20 °C

Sample was cut into 25mm width by 150mm length. The cut sample was applied to aluminum panel and mortar panel respectively. After standing for 48 hours at 20 °C, 180 ° peel force was measured with a tensile testing machine (Tensilon produced by A&D Company, Limited) , in accordance with JIS Z 0237 8.2.3. The tension rate was 300mm/min.

15

65 °C

Sample was cut into 25mm width by 150mm length. The cut sample was applied to aluminum panel and mortar panel respectively. After standing for 48 hours at 20 °C, the sample was stored in an oven at 65 °C, then 180 ° peel force was measured with a tensile testing machine (Tensilon produced by A&D Company, Limited). The tension rate was 300mm/min.

20

The results are shown in Table 3.

Example 10

25 Sample preparation

The sample of Example 10 was prepared as follows. The materials used are as shown in Table 1.

Steps 1 to 4:

Preparation of image-receiving film (transparent film layer), coating of bead coat layer 1, coating of bead coat layer 2 and printing of design layer were conducted in the same manner as Example 1, then the intermediate sample including the first and second bead coat layers, the image-receiving film and the design layer was obtained.

30

Step 5: Preparation of a white adhesive on Aluminum foil

Ten parts by mass of P1, 50 parts by mass of titanium oxide (R960, made by DuPont), and 40 parts by mass of MIBK were prepared and obtained a solution. The solution was mixed with Paint shaker (ARE250, made by Thinky) for 10 minutes, then pre-mix solution was obtained. To the pre-mix solution, 100 parts by mass of P3 and CL3 was added (P3:CL3=100:0.2 in solid ratio).

35

40 parts by mass of methyl isobutyl ketone (MIBK) was added to 10 parts by mass of an acrylic resin 1 (compositional ratio of methyl methacrylate (MMA)/butyl methacrylate (BMA)/dimethyl aminoethyl methacrylate (DMAEMA) = 60:34:6 (mass ratio); weight average molecular weight (Mw) = approximately 70,000; Tg = approximately 66°C; supplied as an ethyl acetate solution) and 50 parts by mass of titanium oxide (TiPure R960 produced by DuPont), and agitated for 10 minutes in a paint shaker (ARE250 manufactured by Thinky Corporation), so as to obtain a pigment premix solution.

Next, an adhesive component obtained by adding 50 parts by mass of titanium oxide 1 and 10 parts by mass of the acrylic resin 1 to 100 parts by mass of an adhesive polymer 1 (compositional ratio of butyl acrylate (BA)/acrylic acid (AA) = 96:4 (mass ratio); Tg = approximately -50°C; Mw = approximately 580,000; supplied as an ethyl acetate/toluene solution) was blended with the obtained pigment premix, thereby preparing a white adhesive composition solution. 0.2 parts by mass (in terms of solid content) of CL3 was added to 100 parts by mass of PSA1. Compatibility of the tacky adhesive and the pigment was good, and dispersion was easily achieved. A white adhesive layer was obtained by coating the obtained white adhesive composition solution on an aluminum foil having a thickness of 50 µm by using a knife coater so that the thickness of the coating layer after drying was 30 µm, and then heating for 5 minutes at 90°C, drying and crosslinking. The white adhesive was protected by bonding a silicon-treated polyester liner having a thickness of 25 µm.

Step 6: Coating PSA and ebeam curing

Rubber PSA1 was knife-coated on the silicone coated paper release liner and dried at 90 °C for 5 minutes, then 50 µm thick PSA was obtained. The obtained PSA was exposed to 1 Mrad of ebeam. The PSA was laminated to aluminum layer obtained in Step 5.

Example 11

Example11 was prepared in the same manner as Example 1 except that ebeam dose was 2Mrad.

Example 12

Example12 was prepared in the same manner as Example1 except that E-beam dose was 4Mrad.

Example 13

Example 13 was prepared in the same manner as Example1 except that Ebeam dose was 6Mrad.

Example14

Example 14 was prepared in the same manner as Example 11 except that CL4 was added to PSA1, where the ratio was PSA1:CL4=100:0.78.

Example 15

5 Example 15 was prepared in the same manner as Example 12 except that CL4 was added to PSA1, where the ratio was PSA1:CL4=100:0.78.

Example 16

10 Example 16 was prepared in the same manner as Example 13 except that CL4 was added to PSA1, where the ratio was PSA1:CL4=100:0.78.

Example 17

15 Example 17 was prepared in the same manner as Example 14 except that none of Ebeam was exposed.

Example 18

Example 18 was prepared in the same manner as Example 1 except that none of Ebeam was exposed.

20 Example 19

Example 19 was prepared in the same manner as Example 1 except that PSA2 was coated by twin screw extruder. Coating weight of PSA2 was 87 g/sqm. Ebeam dose was 4Mrad.

Example 20

25 Example 20 was prepared in the same manner as Example 19 except that the coating weight of PSA2 was 217 g/sqm.

[Table 1]

	Ingredient	Tg (°C cal.)	Molecular Weight	Diluting solvent	Solid content (%)
Polymer 1 (P1), High Tg acrylic polymer	MMA-BMA-DMAEMA=60:34:6	63	68,000	ethyl acetate	40
Polymer 2 (P2), Low Tg acrylic polymer	BA-AA=94:6	-48	760,000	Toluene/ethanol	33
Polymer 3 (P3), Low Tg acrylic polymer	BA-AA=96:4	-50	580,000	Toluene/ethanol	33
Polyurethane resin (PU1)	Polyurethane resin (MCPV-12 produced by Nippon Polyurethane Industry Co., Ltd.)	**	**	MEK/cyclohexane	30
Polyurethane resin (PU2)	Polyurethane resin (Nippollan 5196 produced by Nippon Polyurethane Industry Co., Ltd.)	**	**	MEK/cyclohexane	30
Fluorine additive 1 (FA1)	Perfluoroalkyl group-containing oligomer (Megafac MCF-350 produced by DIC)	**	**	**	100
Alumina beads 1 (Beads 1)	Alumina beads (Alunabeads® CB-A30S produced by Showa Denko Kabushiki Kaisha) D50 = 28.1 μm	**	**	**	100
Alumina beads 2 (Beads 2)	Alumina beads (Alunabeads® CB-A50S produced by Showa Denko Kabushiki Kaisha) D50 = 48.6 μm	**	**	**	100
Alumina beads 3 (Beads 3)	Alumina beads (Alunabeads® CB-A40 produced by Showa Denko Kabushiki Kaisha) D50 = 41.1 μm	**	**	**	100
Alumina beads 4 (Beads 4)	Alumina beads (Alunabeads® CB-A20S produced by Showa Denko Kabushiki Kaisha) D50 = 22.1 μm	**	**	**	100
Crosslinking agent 1 (CL1)	Epoxy crosslinking agent (E-AX produced by Soken Chemical & Engineering Co., Ltd.)	**	**	Toluene	5
Crosslinking agent 2 (CL2)	Isocyanate (Coronate HX produced by Nippon Polyurethane Industry Co., Ltd.)	**	**	**	100
Crosslinking agent 3 (CL3)	Bisamide (1,1'-isophtharoyl-bis(2-methylimidazole))	**	**	Toluene	5
Crosslinking agent 4 (CL4)	Isocyanate (Coronate L55E produced by Nippon Polyurethane Industry Co., Ltd.)	**	**	Ethanol	55
Rubber PSA1	Butadiene rubber 28% Butadiene-styrene copolymer	**	**	Toluene n-hexane	40

	9% Terpene resin 28% Calcium carbonate 18% Petroleum resin 7% Phenol resin 6% Aluminum hydroxide 4%			IPA	
Rubber PSA2	Polybutadiene elastomer 47% Alpha-pinene tackifier 53%	**	**	None	100

[Table 2]

Sample	Bead coat layer 1		Bead coat layer 2		Stationary steering test	Abrasion resistance test	Skid resistance test
	Median diameter	Coating weight (g/m ²)	median diameter	Coating weight (g/m ²)	Result	(Revolutions)	(B.P.N)
Ex 1	28.1 μm	37	48.6 μm	28	Pass	1600	64
Ex 2	28.1 μm	37	48.6 μm	33	Pass	1900	63
Ex 3	28.1 μm	37	48.6 μm	37	Pass	1900	61
Ex 4	28.1 μm	37	28.1 μm	39	Pass	1600	42
Ex 5	28.1 μm	37	28.1 μm:48.6 μm = 8:2	38	Pass	1700	43
Ex 6	28.1 μm	37	28.1 μm:48.6 μm = 9:1	40	Pass	1700	43
CEx 1	28.1 μm	37	none		Pass	1100	39
CEx 2	41.1 μm	74	none		Pass	300	80
CEx 3	41.1 μm	84	none		Fail	500	66
CEx 4	41.1 μm	88	none		Pass	700	62
CEx 5	41.1 μm	96	none		Fail	900	62
CEx 6	48.6 μm	80	none		Pass	500	53
CEx 7	48.6 μm	88	none		Pass	800	45
CEx 8	48.6 μm	110	none		Fail	900	44
Ex 7	48.6 μm	35	28.1 μm	44	Pass	3000	47
Ex 8	28.1 μm	37	22.1 μm	26	Pass	1300	43
Ex 9	28.1 μm	37	22.1 μm	33	Pass	1300	37
CEx 9	28.1 μm:48.6 μm = 2:8	27	none		Pass	500	66
CEx 10	28.1 μm:48.6 μm = 5:5	25	none		Pass	500	57
CEx 11	28.1 μm:48.6 μm = 8:2	33	none		Pass	800	60

[Table 3]

Sample	PSA	Crosslinking agent	Ebeam irradiance (Mrad)	Adhesion			
				Aluminum panel		Mortar	
				20°C (N/25mm)	65°C (N/25mm)	20°C (N/25mm)	65°C (N/25mm)
Example 10	PSA1	None	1	41	12	34	15
Example 11	PSA1	None	2	45	22	33	21
Example 12	PSA1	None	4	35	16	31	20
Example 13	PSA1	None	6	35	15	25	18
Example 14	PSA1	CL4	2	40	19	31	28
Example 15	PSA1	CL4	4	34	14	28	21
Example 16	PSA1	CL4	6	30	13	27	17
Example 17	PSA1	CL4	None	51	8	51	17
Example 18	PSA1	None	None	46	6	47	6
Example 19	PSA2(20 grain)	None	4	47	15	49	22
Example 20	PSA2(50 grain)	None	4	74	27	83	34

5 Reference Numerals

10 Decorative sheet

1 Adhesive layer

2 Metal layer

10 3 Bonding layer

4 Design layer

5 Transparent film layer (image-receiving film)

6 First bead coat layer

7 Second bead coat layer

15 8 Particles in first bead coat layer

9 Particles in second bead coat layer

What is claimed is:

1. A decorative sheet comprising a first bead coat layer including a resin and particles having a median diameter of from 20 μm to 60 μm , a second bead coat layer which is coated on the first bead coat layer and which includes a resin and particles having a median diameter of from 20 μm to 60 μm , a design layer, and an adhesive layer.
5
2. The decorative sheet according to claim 1, wherein the median diameter of the particles contained in the second bead coat layer is greater than the median diameter of the particles contained
10 in the first bead coat layer.
3. The decorative sheet according to claim 1, wherein the median diameter of the particles contained in the second bead coat layer is less than the median diameter of the particles contained in the first bead coat layer.
15
4. The decorative sheet according to any one of claims 1 to 3, which contains an adhesive layer, a metal layer, a bonding layer, a design layer, a transparent film layer, a first bead coat layer and a second bead coat layer in that order.
- 20 5. The decorative sheet according to claim 4, wherein the bonding layer contains a colored adhesive.
6. The decorative sheet according to claim 5, wherein the colored adhesive contains titanium oxide.
25
7. The decorative sheet according to any one of claims 1 to 6, wherein the adhesive layer contains an adhesive comprising crosslinked acrylic-based adhesive polymer.
8. The decorative sheet according to any one of claims 1 to 6, wherein the adhesive layer
30 comprises an adhesive comprising rubber-based adhesive and the surface of the adhesive layer is treated with ebeam.

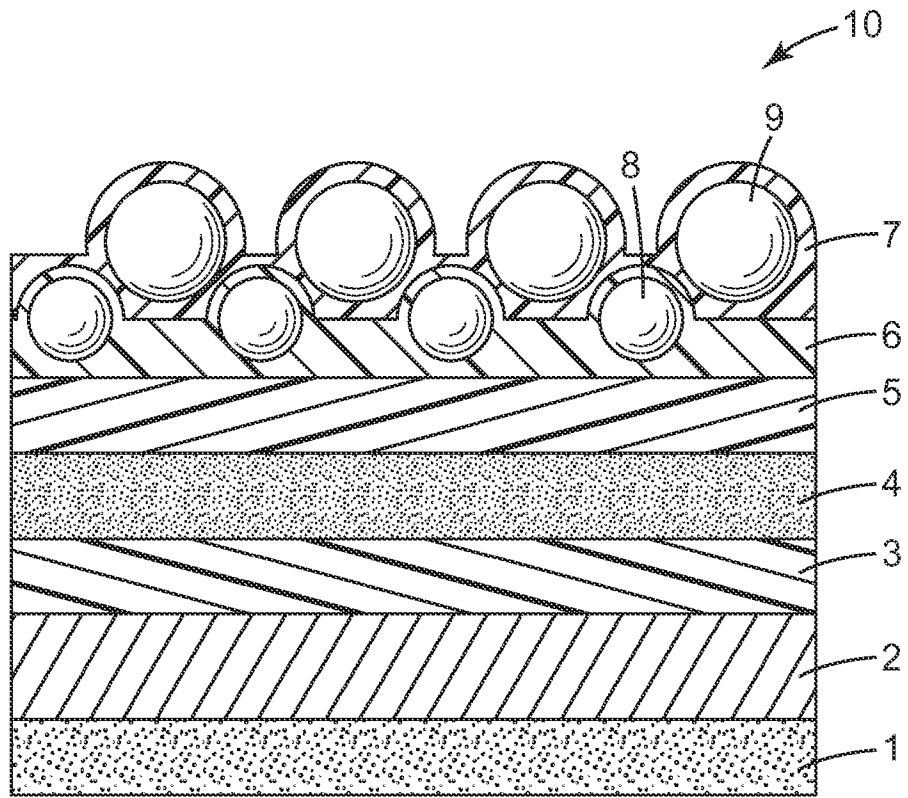

Fig. 1

INTERNATIONAL SEARCH REPORT

International application No.
PCT/US2012/059648**A. CLASSIFICATION OF SUBJECT MATTER***B44C 1/165(2006.01)i, B44C 3/02(2006.01)i*

According to International Patent Classification (IPC) or to both national classification and IPC

B. FIELDS SEARCHED

Minimum documentation searched (classification system followed by classification symbols)

B44C 1/165; B32B 15/04; B32B 3/16; B32B 27/30; B32B 5/16; B32B 3/10; B32B 3/18; B32B 7/12; B44C 1/17

Documentation searched other than minimum documentation to the extent that such documents are included in the fields searched

Korean utility models and applications for utility models

Japanese utility models and applications for utility models

Electronic data base consulted during the international search (name of data base and, where practicable, search terms used)

eKOMPASS(KIPO internal) & Keywords: decorative sheet, bead coat layer, design layer, adhesive layer

C. DOCUMENTS CONSIDERED TO BE RELEVANT

Category*	Citation of document, with indication, where appropriate, of the relevant passages	Relevant to claim No.
X	US 2003-0044600 A1 (OKUYAMA, T) 06 March 2003 See paragraphs [0018]- [0025], [0036]-[0039], [0051], [0071]-[0072], [0081];	1,4
A	claims 1-3, 9-10; and figure 2.	2,3,5-6
A	US 2007-0237929 A1 (SUGA, K.) 11 October 2007 See paragraphs [0024], [0026], [0051], [0063], [0066]; claim 1; and figures 1-2.	1-6
A	US 04849265 A (UEDA; MINORU et al.) 18 July 1989 See column 2, lines 40-47, column 3, lines 30-50; claim 1; and figures 1-4.	1-6
A	US 6297297 B1 (BROOKMAN; ROBERT S. et al.) 02 October 2001 See claims 1-2, 5, 13-14.	1-6
A	US 2010-0166997 A1 (CHISAKA HAJIME et al.) 01 July 2010 See paragraphs [0015], [0023]; claim 13; and figure 2.	1-6

 Further documents are listed in the continuation of Box C. See patent family annex.

* Special categories of cited documents:

"A" document defining the general state of the art which is not considered to be of particular relevance

"E" earlier application or patent but published on or after the international filing date

"L" document which may throw doubts on priority claim(s) or which is cited to establish the publication date of citation or other special reason (as specified)

"O" document referring to an oral disclosure, use, exhibition or other means

"P" document published prior to the international filing date but later than the priority date claimed

"T" later document published after the international filing date or priority date and not in conflict with the application but cited to understand the principle or theory underlying the invention

"X" document of particular relevance; the claimed invention cannot be considered novel or cannot be considered to involve an inventive step when the document is taken alone

"Y" document of particular relevance; the claimed invention cannot be considered to involve an inventive step when the document is combined with one or more other such documents, such combination being obvious to a person skilled in the art

"&" document member of the same patent family

Date of the actual completion of the international search

26 March 2013 (26.03.2013)

Date of mailing of the international search report

27 March 2013 (27.03.2013)

Name and mailing address of the ISA/KR

Korean Intellectual Property Office
189 Cheongsu-ro, Seo-gu, Daejeon Metropolitan
City, 302-701, Republic of Korea

Facsimile No. 82-42-472-7140

Authorized officer

YANG, In Su

Telephone No. 82-42-481-8131



INTERNATIONAL SEARCH REPORT

International application No.

PCT/US2012/059648

Box No. II Observations where certain claims were found unsearchable (Continuation of item 2 of first sheet)

This international search report has not been established in respect of certain claims under Article 17(2)(a) for the following reasons:

- 1. Claims Nos.:
because they relate to subject matter not required to be searched by this Authority, namely:

- 2. Claims Nos.:
because they relate to parts of the international application that do not comply with the prescribed requirements to such an extent that no meaningful international search can be carried out, specifically:

- 3. Claims Nos.: 7,8
because they are dependent claims and are not drafted in accordance with the second and third sentences of Rule 6.4(a).

Box No. III Observations where unity of invention is lacking (Continuation of item 3 of first sheet)

This International Searching Authority found multiple inventions in this international application, as follows:

- 1. As all required additional search fees were timely paid by the applicant, this international search report covers all searchable claims.

- 2. As all searchable claims could be searched without effort justifying an additional fee, this Authority did not invite payment of any additional fee.

- 3. As only some of the required additional search fees were timely paid by the applicant, this international search report covers only those claims for which fees were paid, specifically claims Nos.:

- 4. No required additional search fees were timely paid by the applicant. Consequently, this international search report is restricted to the invention first mentioned in the claims; it is covered by claims Nos.:

- Remark on Protest**
- The additional search fees were accompanied by the applicant's protest and, where applicable, the payment of a protest fee.
 - The additional search fees were accompanied by the applicant's protest but the applicable protest fee was not paid within the time limit specified in the invitation.
 - No protest accompanied the payment of additional search fees.

INTERNATIONAL SEARCH REPORT

Information on patent family members

International application No.

PCT/US2012/059648

Patent document cited in search report	Publication date	Patent family member(s)	Publication date		
US 2003-0044600 A1	06.03.2003	AT 305385 T	15.10.2005		
		AU 2001-49905 A1	23.10.2001		
		AU 4990501 A	23.10.2001		
		DE 60113667 D1	09.02.2006		
		DE 60113667 T2	06.07.2006		
		EP 1274570 A2	15.01.2003		
		EP 1274570 B1	28.09.2005		
		JP 2001-295454 A	26.10.2001		
		KR 10-2002-0084293 A	04.11.2002		
		US 6767630 B2	27.07.2004		
		WO 01-76867 A2	18.10.2001		
		WO 01-76867 A3	24.01.2002		
		US 2007-0237929 A1	11.10.2007	CN 101045348 A	03.10.2007
				CN 101045348 C0	03.10.2007
DE 602007000359 D1	29.01.2009				
EP 1839835 A1	03.10.2007				
EP 1839835 B1	17.12.2008				
JP 2007-261143 A	11.10.2007				
KR 10-2007-0098665 A	05.10.2007				
KR 20070098665 A	05.10.2007				
US 04849265 A	18.07.1989	JP 01-063141 A	09.03.1989		
		JP 2546853 B2	23.10.1996		
US 6297297 B1	02.10.2001	None			
US 2010-0166997 A1	01.07.2010	AT 477074 T	15.08.2010		
		BR P10709000 A2	21.06.2011		
		CA 2647072 A1	27.09.2007		
		CN 101405137 A	08.04.2009		
		DE 602007008375 D1	23.09.2010		
		EP 1996356 A2	03.12.2008		
		EP 1996356 B1	11.08.2010		
		JP 2007-253370 A	04.10.2007		
		JP 4878884 B2	15.02.2012		
		KR 10-2008-0106274 A	04.12.2008		
		KR 20080106274 A	04.12.2008		
		WO 2007-109763 A2	27.09.2007		
		WO 2007-109763 A3	17.04.2008		