

Aug. 27, 1963

O. A. WANDEL  
FASTENER DRIVING APPARATUS

3,101,476

Filed Sept. 11, 1961

Fig. 1

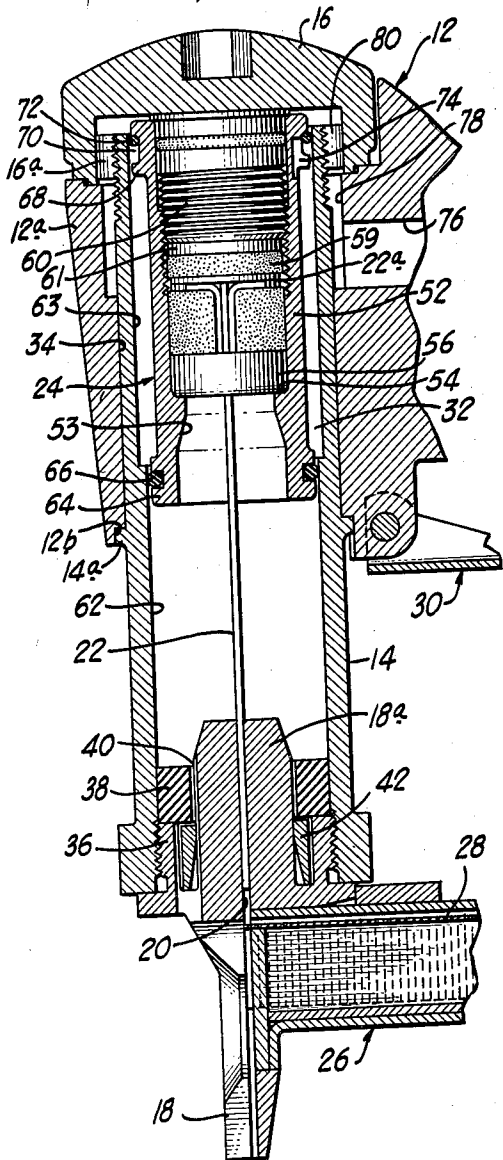

Fig. 2

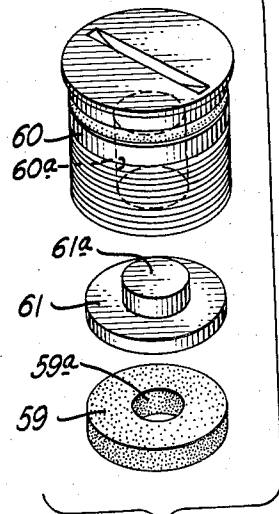
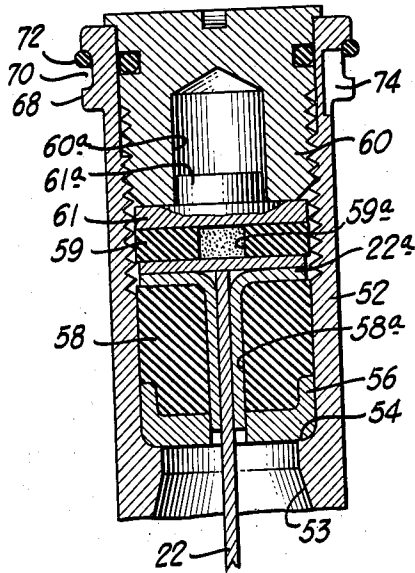

Fig. 3

INVENTOR.

OSCAR A. WANDEL

BY

Mason, Kolehmainen, Rathburn and Wyss  
ATTORNEYS

1

3,101,476

## FASTENER DRIVING APPARATUS

Oscar A. Wandel, Mundelein, Ill., assignor to Fastener Corporation, Chicago, Ill., a corporation of Illinois  
 Filed Sept. 11, 1961, Ser. No. 137,313  
 1 Claim. (Cl. 1-44.4)

This invention relates to a fastener driving apparatus and, more particularly, to a pneumatically operated stapler including a new and improved piston and driver blade assembly.

In pneumatic fastener driving tools, pneumatic means, including a pneumatically operated piston, are provided for delivering a fastener driving stroke to a driver blade operatively connected to the piston and additional pneumatic or spring means have been provided for returning the piston and blade to a normal position at the conclusion of the fastener driving stroke. One such arrangement is described in my copending application Serial No. 832,800, filed August 10, 1959, now Patent No. 3,040,709. This copending application discloses a pneumatically actuated fastener driving tool including a cylinder closed at the upper end by a closure cap and at the lower end by a nosepiece in which is formed a drive track for receiving a driver blade connected to a piston assembly which is slidably mounted within the cylinder. The piston assembly includes a piston sleeve having an axially extending inner opening provided with a shoulder on which a retaining plate is mounted. The driver blade is resiliently connected with the piston assembly by a resilient member which is disposed between the retaining plate and a T-shaped head formed on the driver blade so as to cushion the shock transmitted to the blade when the piston reaches the end of its driving stroke in a fastener driving operation.

The piston member however has heretofore been solidly positioned against the upper surface of the driver blade in metal-to-metal contact so that no cushioning was introduced into the driving system when the driver blade engaged a fastener or when the piston and blade assembly stopped at the end of its return stroke. This metal-to-metal contact between the blade and the piston was used because it was believed that resilient means positioned between the piston assembly and the top of the driver blade transmitting the fastener driving load from the piston assembly to the blade would adversely alter the driving characteristics of the fastener driving stroke. However, this rigid connection between the piston assembly and the driver blade during the driving stroke has resulted in excessive wear and occasional breakage of the driver blade and other parts of the fastener driving apparatus.

Accordingly, it is an object of the present invention to provide a new and improved fastener driving tool.

Another object of the present invention is to provide a pneumatically actuated fastener driving tool including a new and improved pneumatic piston and driver blade assembly.

A further object of the present invention is to provide a new and improved fastener driving tool having a new and improved piston and driving blade assembly wherein the driver blade is cushioned during the driving stroke of the assembly.

In accordance with these and many other objects, an embodiment of the present invention comprises a pneumatically actuated fastener driving tool including a housing having both a cylindrical opening at its front end within which a cylinder is mounted and a rearwardly extending hollow handle providing a reservoir of compressed air. The upper end of the cylinder is closed by a closure cap which also serves to secure the cylinder on

2

the housing, and the lower end of the cylinder is closed by a nosepiece in which is formed a drive track for receiving a driver blade connected to a piston which is slidably mounted within the cylinder. A staple magazine which is secured between the nosepiece and a downwardly extending rear portion of a handle supplies staples to the drive track for setting by the driver blade.

In accordance with the present invention, the piston assembly of the present tacker includes a piston sleeve having an axially extending inner opening provided with a shoulder upon which a retaining plate is mounted and closed by a cap member at its upper end, thereby forming an opening between the plate and the cap member. The driver blade is provided with an upper T-shaped portion positioned within the opening, and the blade extends through an opening in the retaining plate. A pair of resilient members are positioned on each side of the transverse T-shaped portion, the T-shaped portion being secured within the opening by a first of the resilient members positioned below the lower surface thereof and the upper surface of the retaining plate, and the second of the resilient members being positioned between the upper surface of the T-shaped portion and the lower surface of the cap member. In this manner, the driver blade is resiliently connected to the piston assembly during both the driving stroke and the return stroke of the assembly.

Many other objects and advantages of the present invention will become apparent from the following detailed description when considered in conjunction with the drawings, in which:

FIG. 1 is a fragmentary side sectional view of a fastener driving tool embodying the present invention;

FIG. 2 is an enlarged sectional view of a piston assembly included in the tool shown in FIG. 1; and

FIG. 3 is an exploded perspective view illustrating certain of the component parts of the piston assembly.

Referring now to the drawing, there is illustrated a pneumatically actuated fastener driver or stapler which is generally identical to the pneumatically operated stapler shown and described in my above-mentioned copending application and in my copending application Serial No. 527,697, filed August 11, 1955, which is assigned to the same assignee as the present application.

The stapler includes a housing 12 on which a cylinder 14 is detachably mounted. The open upper end of the cylinder 14 is closed by a closure cap 16 which additionally serves to secure the cylinder 14 to the housing 12. The lower end of the cylinder 14 is closed by a nosepiece structure 18 defining a drive track 20 in which is slidably mounted the lower end of a fastener driving blade 22. The upper end of the blade 22 is secured to a piston assembly, indicated generally as 24, which is slidably mounted within the cylinder 14. A magazine assembly, indicated generally at 26, is secured at its opposite ends to the nosepiece structure 18 and the housing 12 (not shown in FIG. 1) and serves to supply staples 28 to the drive track 20.

When the tacker is to be actuated, a control valve assembly, fragmentarily illustrated at 30, is manually actuated to supply air to the open upper end of the cylinder 14. This compressed air drives the piston assembly 24 and the blade 22 downwardly so that the fastener 28 supplied by the magazine assembly 26 is driven into a workpiece. Some of the compressed air that is admitted to the upper end of the cylinder 14 flows into the interface between the upper end of the piston 24 and the wall of the cylinder 14 to be accumulated within an annular piston return chamber 32. Thus, when the valve assembly 30 is released, the upper end of the cylinder 14 is exhausted to the atmosphere, as more fully described in the above-mentioned application Serial No. 832,800, and

the air entrapped within the annular return chamber 32 develops an upwardly directed force which returns the piston assembly 24 and the driver blade 22 from a depressed position to the normal position illustrated in FIG. 1.

The housing 12 comprises a forward portion 12a which defines a cylindrical opening 34 in which the upper end of the cylinder 14 is slidably mounted so that a flange 14a on the cylinder is received within an annular recess 12b in the lower edge of the front portion 12a of the housing 12. The upper end of the cylinder 14 is threaded to be engaged by four peripherally spaced and radially inwardly projecting threaded portions 16a on the closure cap 16. Thus, when the cap 16 is threaded onto the upper end of the cylinder 14, the flange 14a is clamped against the front portion 12a of the housing 12 and the lower edge of the closure cap 16 is drawn into engagement with the upper end of the portion 12a.

The lower end of the cylinder 14 is closed by the nose-piece structure 18 which includes an upwardly extending and externally threaded flange 36 for threadedly engaging an inner surface on the lower end of the cylinder 14. An annular resilient ring 38 is mounted on the upper edge of the flange 36 to provide a buffer for an arresting downward movement of the piston assembly 24. The nose-piece structure 18 also includes an upwardly extending boss 18a which increases the length of the guide track 20 to provide a greater effective guiding surface for the driver blade 22 to insure that this blade does not become "cocked" during movement. A slot 40 formed in the nosepiece structure 18 and in the boss 18a provides a passage for connecting the lower portion of the cylinder 14 to the atmosphere. A spacer ring 42 is positioned within the annular groove formed between the boss 18a and the annular flange 36.

To provide means for successively feeding individual staples 28 from a strip thereof into the drive track 20, the magazine assembly 26 is provided. This magazine assembly can be of any suitable construction well known in the art although it preferably comprises a magazine assembly of the type shown and described in detail in my above-mentioned copending application Serial No. 527,697. The front end of the magazine assembly 26 is secured to the nosepiece structure 18 and the rear end of this assembly is secured to a depending portion of the housing.

Referring now more specifically to the piston assembly 24, this assembly includes a piston sleeve 52, FIGS. 1 and 2, having an axially extending inner opening 53 provided with a shoulder 54 on which a retaining plate 56 is mounted. To resiliently interconnect the drive blade 22 with the piston assembly 24, a pair of resilient or compressible members or washers 58 and 59 are disposed on opposite sides of a T-shaped head 22a formed on the driver blade 22. One of the resilient members 58 is disposed between the retaining plate 56 and the T-shaped head 22a and is provided with an axial opening 58a through which the blade 22 extends. The member 58 cushions the blade 22 during its fastener driving stroke when it reaches the bottom of its travel.

The second resilient member 59 is annularly shaped with an axial opening 59a and is disposed between a cap member 60 threadedly mounted in the upper end of the opening 53 and the upper surface of the T-shaped portion 22a to thus secure the blade 22 resiliently with reference to the piston assembly 24 and to provide for cushioning of the blade 22 during the power stroke of the fastener driving apparatus and additionally to cushion the driver blade 22 upon return of the piston assembly 24 to its normal position. To provide a bearing member between the resilient member 59 and the cap member 60, there is provided a metal slug or washer 61 positioned between the resilient member 59 and the cap member 60. The washer 61 is provided with an upwardly extending cylindrical portion 61a freely positioned with a downwardly

or inwardly opening cylindrical recess 60a in the cap member 60. Accordingly, when the cap member 60 is assembled with the piston sleeve 52 by turning the cap member 60, metallic bearing surfaces are provided between the cap member 60 and the washer 61.

As more fully described in my above-mentioned copending application Serial No. 832,800, to provide a pneumatic return means for the driver blade 22 and the piston assembly 24, the cylinder 14 is provided with a lower portion 62 of lesser diameter and an upper portion 63 of greater diameter. The lower end of the piston sleeve 52 is formed with a radially projecting flange 64 of lesser diameter and an upper portion 63 of greater diameter. The lower end of the piston sleeve 52 is formed with a radially projecting flange 64 of lesser diameter which carries a sealing O-ring 66 that slides in engagement with the inner surface of the lower portion 62 of the cylinder 14. The upper end of the piston sleeve 52 is provided with an annular flange 68 of greater diameter which is provided with an enlarged annular groove 70. A resilient O-ring 72 is movably mounted within the groove 70 and slidably engages the inner wall of the upper portion 63 of the cylinder 14. The body of the piston sleeve 52 is recessed between the upper and lower flanges 64 and 68 to cooperate with the inner wall of the cylinder 14 to define the air return chamber 32.

To provide means for selectively supplying compressed air to the air return chamber 32, the bottom wall of the groove 70 and a portion of the lower lip of this groove are recessed to provide a slot 74 which places the air return chamber 32 in communication with the annular groove 70. Thus, when compressed air is supplied to the upper end of the cylinder 14, the air passing through the interface between the upper flange 68 and the inner wall of the upper portion 63 of the cylinder 14 enters the groove 70 and passes through the slot 74 to be accumulated in the air return chamber 32.

When a fastener 28 is to be driven, the control assembly 30 is manually operated to supply air from the compressed air reservoir formed by the hollow handle of the housing 12 through a passageway 76, an enlarged portion 78 formed in the opening 34 and four peripherally spaced passageways 80 in the closure cap 16 to the open upper end of the cylinder 14. This compressed air acts on the upper surface of the piston assembly 24 to move this assembly and the driver blade 22 downwardly. During this movement, the lower end of the blade 22 moves downwardly through the guide track 20 to engage and set the staple 28 supplied by the magazine assembly 26. When compressed air is admitted to the upper end of the cylinder 14, a portion of this air passes through the interface at the upper end of the piston assembly 24 or around the upper lip of the groove 70 and into this groove to move the O-ring 72 to its lower position. The compressed air then enters the annular groove 70 and is permitted to flow through the slot 74 into the air return chamber 32. Because of the recessed outer surface of the piston sleeve 52, an appreciable volume of compressed air can be accumulated between the outer surface of the piston assembly 24 and the inner wall of the cylinder 14.

When the control valve assembly 30 is released so that the passageway 16 and the interior of the upper portion 63 of the cylinder 14 are connected to atmosphere, the compressed air within the air return chamber 32 acts on the O-ring 72 to displace this O-ring to the position illustrated in FIGS. 1 and 2. In this position, the O-ring engages the upper lip of the groove 70 and seals the interface between the upper flange 68 and the inner wall of the upper portion 63 of the cylinder 14. The compressed air in the air return chamber 32 expands and, because of the difference in the effective areas of the lower flange 64 and the upper flange 68, provides an upwardly directed force for returning the piston assembly 24 and the driver blade 22 to their normal positions in which

5

the upper end of the element 60 engages the lower surface of the closure cap 16.

It will be appreciated that the mounting of the driver blade 22 between the pair of resilient members 59 is effective to cushion both the downward or power stroke and the upward or return stroke of the piston and blade assemblies. Moreover, it has been found that a cushioning of the blade assembly during the power stroke by the upper element 60 is effective to reduce wear and breakage of the components and particularly of the driver blade 22 without objectionably altering the operating characteristics of the driving apparatus.

Although the present invention has been described with reference to a particular embodiment thereof, it should be understood that those skilled in the art may make other modifications and embodiments which will fall within the spirit and scope of the principles of this invention.

What is claimed as new and desired to be secured by Letters Patent of the United States is:

A fastener driving apparatus comprising a cylinder, nosepiece structure closing the lower end of said cylinder and including a guiding portion, a piston assembly slidably mounted in said cylinder to provide a driving stroke

6

and a return stroke, said piston assembly including a piston sleeve provided with an upwardly extending shoulder, a retaining plate slidably mounted on said shoulder, and a cap member threadedly mounted in the upper end of said piston sleeve spaced from said retaining plate to form a recess intermediate said retaining plate and said cap member, said retaining plate having an opening communicating with said recess; a driver blade mounted for sliding movement relative to said guiding portion and provided with a T-shaped head positioned in said recess, said blade extending through said opening, a first resilient washer positioned between said T-shaped head and said retaining plate; and a second resilient washer positioned between said T-shaped head and said cap member whereby said piston is cushioned by the engagement of said blade with a fastener and by the engagement of said piston assembly with stop means when said piston assembly is moved toward a workpiece.

References Cited in the file of this patent

UNITED STATES PATENTS

387,234	Hutchinson	Aug. 7, 1888
2,983,922	Juilfs	May 16, 1961