

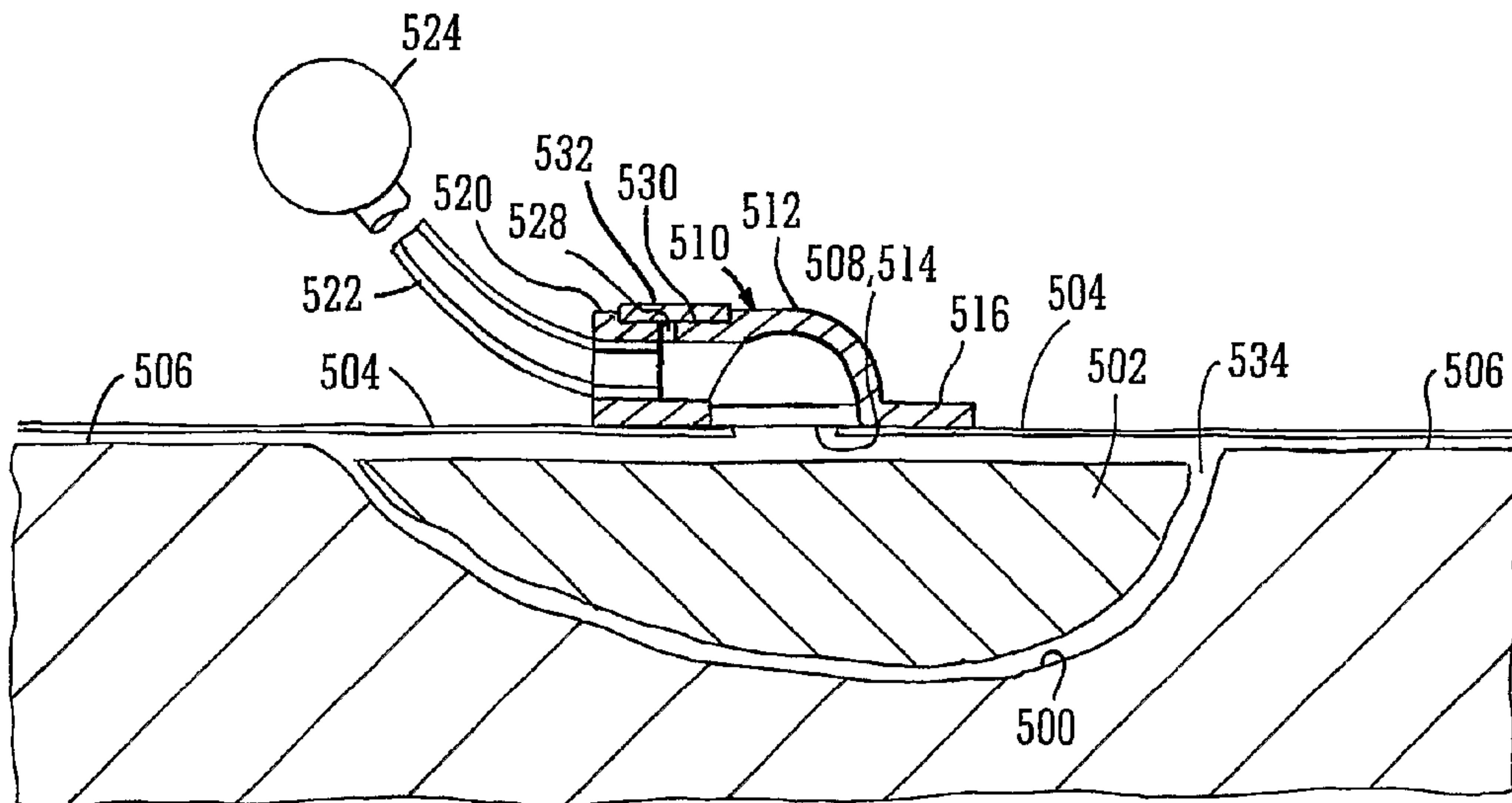

(86) **Date de dépôt PCT/PCT Filing Date:** 2008/11/26
 (87) **Date publication PCT/PCT Publication Date:** 2009/06/11
 (45) **Date de délivrance/Issue Date:** 2016/06/14
 (85) **Entrée phase nationale/National Entry:** 2010/05/18
 (86) **N° demande PCT/PCT Application No.:** GB 2008/051118
 (87) **N° publication PCT/PCT Publication No.:** 2009/071933
 (30) **Priorité/Priority:** 2007/12/06 (GB0723872.8)

(51) **Cl.Int./Int.Cl. A61M 1/00** (2006.01)
 (72) **Inventeurs/Inventors:**
 HALL, KRISTIAN, GB;
 HARTWELL, EDWARD, GB
 (73) **Propriétaire/Owner:**
 SMITH & NEPHEW PLC, GB
 (74) **Agent:** BORDEN LADNER GERVAIS LLP

(54) **Titre : APPAREIL POUR THERAPIE PAR PRESSION NEGATIVE TOPIQUE**
 (54) **Title: APPARATUS FOR TOPICAL NEGATIVE PRESSURE THERAPY**



(57) **Abrégé/Abstract:**

Apparatus and a method for the provision of TNP therapy to a wound are described, the apparatus comprising: a sealing membrane for covering a wound to form a wound cavity; one end of an aspirant conduit operably associated with the wound cavity; vacuum means provided at a distal end of the aspirant conduit for applying a vacuum to the wound cavity; and, air bleed means in fluid communication with the wound cavity. Various embodiments of air bleed port members are also described.

(12) INTERNATIONAL APPLICATION PUBLISHED UNDER THE PATENT COOPERATION TREATY (PCT)

(19) World Intellectual Property Organization
International Bureau(43) International Publication Date
11 June 2009 (11.06.2009)

PCT

(10) International Publication Number
WO 2009/071933 A2(51) International Patent Classification:
A61M 1/00 (2006.01)(21) International Application Number:
PCT/GB2008/051118(22) International Filing Date:
26 November 2008 (26.11.2008)

(25) Filing Language: English

(26) Publication Language: English

(30) Priority Data:
0723872.8 6 December 2007 (06.12.2007) GB(71) Applicant (for all designated States except US): SMITH
& NEPHEW PLC [GB/GB]; 15 Adam Street, London
WC2N 6LA (GB).

(72) Inventors; and

(75) Inventors/Applicants (for US only): HALL, Kristian
[GB/GB]; 20 Barton Drive, Hessle, Hull HU13 0HN (GB).
HARTWELL, Edward [GB/GB]; Smith & Nephew
Research Centre, York Science Park, Heslington, York
YO10 5DF (GB).(74) Agent: BOAKES, Jason, Carrington; Harrison Goddard
Foote, 106 Micklegate, York YO1 6JX (GB).(81) Designated States (unless otherwise indicated, for every
kind of national protection available): AE, AG, AL, AM,
AO, AT, AU, AZ, BA, BB, BG, BH, BR, BW, BY, BZ, CA,
CH, CN, CO, CR, CU, CZ, DE, DK, DM, DO, DZ, EC, EE,
EG, ES, FI, GB, GD, GE, GH, GM, GT, HN, HR, HU, ID,
IL, IN, IS, JP, KE, KG, KM, KN, KP, KR, KZ, LA, LC, LK,
LR, LS, LT, LU, LY, MA, MD, ME, MG, MK, MN, MW,
MX, MY, MZ, NA, NG, NI, NO, NZ, OM, PG, PH, PL, PT,
RO, RS, RU, SC, SD, SE, SG, SK, SL, SM, ST, SV, SY, TJ,
TM, TN, TR, TT, TZ, UA, UG, US, UZ, VC, VN, ZA, ZM,
ZW.(84) Designated States (unless otherwise indicated, for every
kind of regional protection available): ARIPO (BW, GH,
GM, KE, LS, MW, MZ, NA, SD, SL, SZ, TZ, UG, ZM,
ZW), Eurasian (AM, AZ, BY, KG, KZ, MD, RU, TJ, TM),
European (AT, BE, BG, CH, CY, CZ, DE, DK, EE, ES, FI,
FR, GB, GR, HR, HU, IE, IS, IT, LT, LU, LV, MC, MT, NL,
NO, PL, PT, RO, SE, SI, SK, TR), OAPI (BF, BJ, CF, CG,
CI, CM, GA, GN, GQ, GW, ML, MR, NE, SN, TD, TG).

Declaration under Rule 4.17:

— of inventorship (Rule 4.17(iv))

Published:

— without international search report and to be republished
upon receipt of that report

(54) Title: APPARATUS FOR TOPICAL NEGATIVE PRESSURE THERAPY

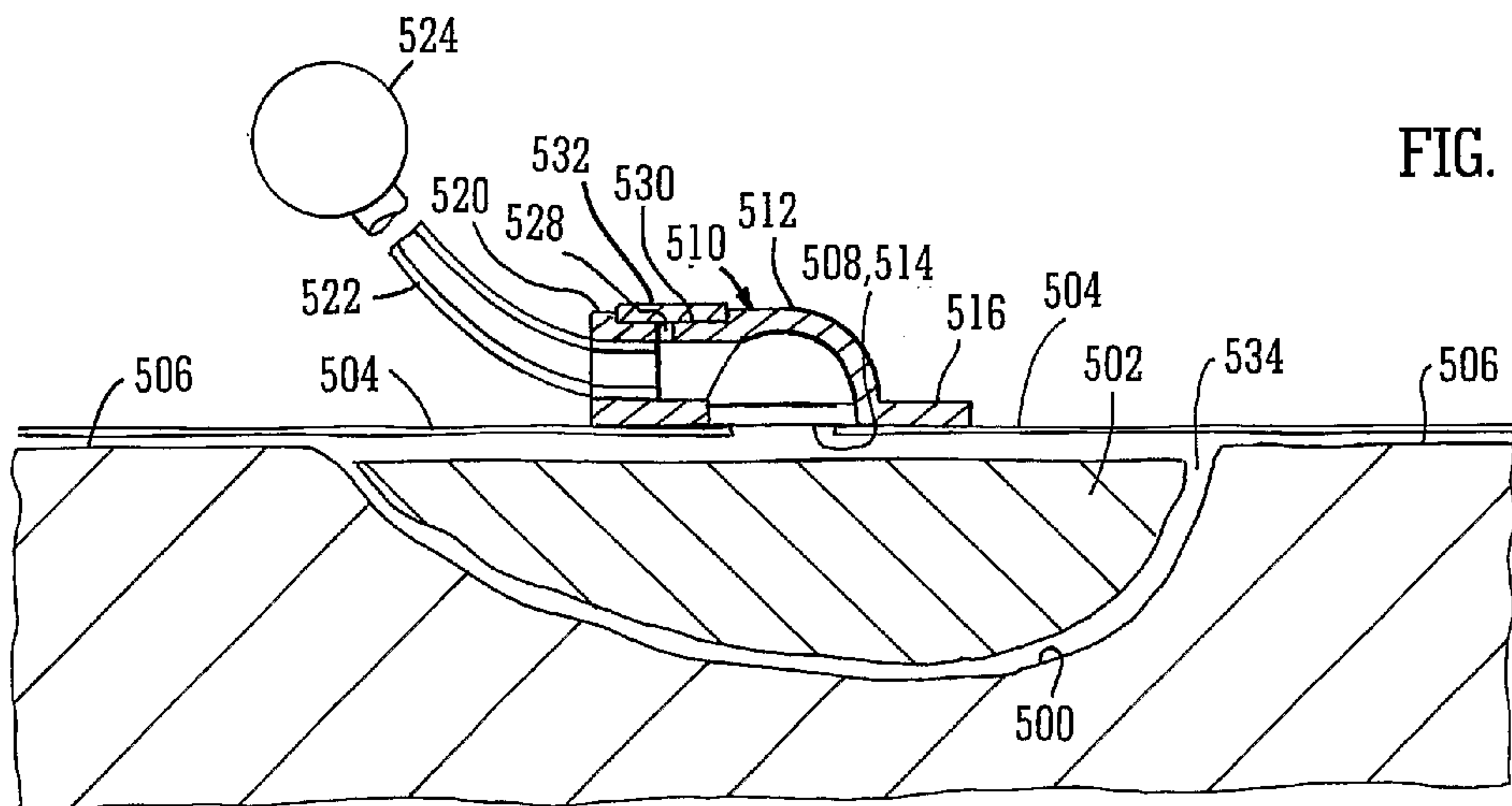

FIG. 5

(57) Abstract: Apparatus and a method for the provision of TNP therapy to a wound are described, the apparatus comprising: a sealing membrane for covering a wound to form a wound cavity; one end of an aspirant conduit operably associated with the wound cavity; vacuum means provided at a distal end of the aspirant conduit for applying a vacuum to the wound cavity; and, air bleed means in fluid communication with the wound cavity. Various embodiments of air bleed port members are also described.

APPARATUS FOR TOPICAL NEGATIVE PRESSURE THERAPY

The present invention relates to topical negative pressure (TNP) therapy particularly, though not exclusively, to the control of negative pressure within a wound dressing.

5

TNP therapy has assumed great importance in recent years due to the beneficial effects of TNP therapy on a healing wound and also because of the accelerated healing which TNP therapy provides.

10 Apparatus for TNP therapy ranges from extremely complex apparatus only really suitable for use in a specialised hospital environment to much smaller and simpler, portable apparatus which may be used by an individual patient at home or at work.

The basic principle of TNP therapy is to create a closed cavity over the wound itself by
15 means of a thin, flexible sealing film adhered to the patient's sound skin surrounding the wound; admitting one end of an aspirant conduit into the closed cavity, the conduit being sealed to the flexible film, for example; and connecting a distal end of the aspirant conduit to a vacuum source such as an electrically driven vacuum pump, for example, to
20 create a pressure lower than the surrounding ambient atmospheric pressure within the wound cavity. As is known to the skilled person the lower pressure creates many beneficial therapeutic effects on the wound including increased blood flow to the wound and faster granulation of tissue, for example.

As noted above TNP therapy may be applied by a diverse range of apparatus. However,
25 in general terms the more complex apparatus tends to be used on larger, more serious wounds which require a more intensive and varied treatments by TNP therapy. Examples of apparatus useful in the context of treatment of such larger wounds are given below.

30 In our co-pending International patent application, WO 2004/037334, apparatus, a wound dressing and a method for aspirating, irrigating and cleansing wounds are described. In very general terms, this invention describes the treatment of a wound by the application of topical negative pressure (TNP) therapy for aspirating the wound together with the further provision of additional fluid for irrigating and/or cleansing the
35 wound, which fluid, comprising both wound exudates and irrigation fluid, is then drawn off by the aspiration means and circulated through means for separating the beneficial

materials therein from deleterious materials. The materials which are beneficial to wound healing are recirculated through the wound dressing and those materials deleterious to wound healing are discarded to a waste collection bag or vessel.

5 In our co-pending International patent application, WO 2005/04670, apparatus, a wound dressing and a method for cleansing a wound using aspiration, irrigation and cleansing wounds are described. Again, in very general terms, the invention described in this document utilises similar apparatus to that in WO 2004/037334 with regard to the aspiration, irrigation and cleansing of the wound, however, it further includes the
10 important additional step of providing heating means to control the temperature of that beneficial material being returned to the wound site/dressing so that it is at an optimum temperature, for example, to have the most efficacious therapeutic effect on the wound.

In our co-pending International patent application, WO 2005/105180, apparatus and a
15 method for the aspiration, irrigation and/or cleansing of wounds are described. Again, in very general terms, this document describes similar apparatus to the two previously mentioned documents hereinabove but with the additional step of providing means for the supply and application of physiologically active agents to the wound site/dressing to promote wound healing.

20

The content of the above references is included herein by reference.

However, the above apparatus and methods are generally only applicable to a patient when hospitalised as the apparatus is complex, needing people having specialist
25 knowledge in how to operate and maintain the apparatus, and also relatively heavy and bulky, not being adapted for easy mobility outside of a hospital environment by a patient, for example.

Whilst the above examples are mainly relevant to the treatment of larger wounds, there
30 is also a need for the treatment of relatively small wounds where the patient may otherwise be fit and mobile and require treatment outside of a clinical setting such as at home or at their workplace but where the provision of TNP therapy is desirable but nevertheless need to provide controlled conditions in the wound cavity. An example of a suitable apparatus is described in our co-pending UK patent application, GB0712736.8,
35 of common ownership herewith, the content of which is included herein by reference.

An unexpected problem with smaller wounds of relatively low surface area is that they are relatively easy to seal in that they generally may have a relatively large area of sound flesh surrounding them and hence have large sealing borders therearound for the sealing film or drape to seal with and which tends to mitigate against inward air leaks from this area of the dressing. Secondly, even though the sealing films, which are well known to those skilled in the art, tend to be semi-permeable membrane type materials which allow to an extent the passage of gas such as air and water vapour, they do so only to a limited extent which is defined or measured in mass flow per unit area. Thus, since the area of the sealing film above the wound is relatively small, the amount of permitted gaseous flow is small. Because the seal over and around the wound may be very good, it is easy to create a vacuum in the wound cavity which does not decay quickly due to leaks, and therefore, very little or no flow through the aspirant conduit may result and whilst the vacuum is there over the wound, the wound exudate may not be being transported away to a waste canister, for example, and may be stagnating at the wound itself, this being especially so at low levels of negative pressure relative to atmospheric pressure. One important feature of TNP therapy is that the wound exudate fluid is desirably transported away from the wound site. Failure to achieve this efficiently may result in increased risk of infection and in the worst cases may result in back flow of wound exudate into the wound cavity.

20

However, whether the wound is large or small the fact is that clinicians strive to seal the wound as well as they possibly can so as to prevent bacteria from causing infection. Larger wounds generate greater volumes of fluid and, are therefore, susceptible to filling the wound cavity with fluid. Furthermore, it is possible for the aspiration conduit to fill with exudate fluid resulting in a pressure differential between the wound and the vacuum source due to the viscous drag of the exudate and the height differential between wound and vacuum source.

25

It is an object of the present invention to mitigate such problems especially, but not exclusively, in portable TNP therapy apparatus and to provide apparatus and a method where reliable flow of wound exudate away from the wound is promoted.

30

According to a first aspect of the present invention there is provided apparatus for the provision of TNP therapy to a wound, the apparatus comprising: a sealing membrane for covering a wound to form a wound cavity in use; an aspirant conduit having one end thereof operably associated with the wound cavity, in use; vacuum means provided at a

35

distal end of the aspirant conduit for applying a vacuum to the wound cavity when in use; and, air bleed means in fluid communication with the wound cavity when in use.

5 In this specification the term "vacuum" means a pressure less than ambient atmospheric pressure.

10 The air bleed means may be switchable in that the air bleed may be turned on and off as desired. In this regard the air bleed means may be provided by a second conduit having one end in communication with the wound cavity and having a filter associated with the conduit and a clamp or valve which enables the filter to admit air from the surrounding atmosphere to the wound cavity under the influence of the vacuum in the wound cavity. Air flow into the conduit may be controlled by the clamp on the conduit or on/off valve controlled by the user/patient or a clinician. An air bleed may be admitted when, for example, the patient observes that the aspirant tube appears to be full of exudate but
15 which is not moving. Opening of the conduit to ambient air then induces a fluid flow in the conduit to expel the exudate into a waste canister, for example, associated with particular TNP apparatus in use.

20 The air bleed means may provide a maximum flow rate at 200 mmHg below atmospheric of up to 1 l/min into the system. Preferably, the flow rate may be a maximum of 0.5 l/min. More preferably the flow rate may be a maximum of 0.2 l/min. More preferably still, a maximum flow rate of 0.05 l/min may be provided into the system. The overriding factor is to achieve a flow rate consistent with the wound not drying out as may happen if the incoming flow rate of bleed air is too high.

25

Control of bleed rate may be achieved by control of the area of the filter through which bleed air may be admitted.

30 Use of a filter is both desirable and advantageous in minimising the risk of pathogens from being admitted to the wound cavity by the air bleed.

The use of a regulator on the second conduit described above may also be employed to achieve a constant but controlled rate of inward air bleed.

35 Alternatively, the air bleed means may be associated with the sealing drape in which an aperture may be formed to permit the attachment of an air bleed port thereto. Such an

air bleed port may have a filter portion or aperture through which ambient air is drawn into the wound cavity by the vacuum. Such an air bleed port may be permanently open to ambient atmosphere but, due to the contained filter portion, may restrict the rate of flow of air into the wound cavity or aspirant conduit to a low rate due to the size of the filter pores. In effect such an air bleed port substitutes for leakage of air into a TNP dressing which normally occurs with larger wounds. Suitable air bleed ports may be manufactured from soft plastics material mouldings so as not to cause trauma to a patient if lain upon. They may be provided during manufacture with a layer of adhesive thereon and suitable protective layer of siliconised paper until needed for use.

10

Such air bleed ports may be sealed off with suitable sealing tape so as to be able to check for leaks in the dressing and/or act as an on/off facility.

15

An air bleed provision may be provided by a second conduit plugged into a suitable grommet sandwiched between two adhesive drape or sealing membrane layers for example as described in our co-pending International patent application, PCT/US2007/074374, based on GB0712735.0, of common ownership herewith and the content of which are included herein by reference.

20

Suitable filters may be 0.2 or 0.1 or 0.02 micron filters, for example, which also have the added advantage in that they may also prevent expulsion of bacteria to atmosphere in the reverse direction if for any reason this might occur.

25

An advantage of the present invention is that use of a filter element of predetermined pore size and area permits close control of a desired low flow rate of ambient air into the wound cavity, the filter element itself also preventing ingress of potentially harmful bacteria. In contrast, conventional valves are insufficiently sensitive to control at the low flow rates required and also do not stop harmful bacterial from entering the wound.

30

In some embodiments of the present invention an air bleed port such as that described above may be provided with the drape or sealing membrane material during manufacture thereof, the air bleed port being adhered or welded to the drape or flexible sealing membrane.

In all embodiments of the present invention the rate of bleed air flow into the dressing and wound cavity is controlled solely by the characteristics of the filter with respect to its pore size and area exposed to ambient atmosphere.

- 5 According to a second aspect of the present invention there is provided an air bleed port member for use with a topical negative pressure dressing.

According to a third aspect of the present invention there is provided a method of providing topical negative pressure therapy to a wound, the method comprising the steps
10 of: providing a sealing membrane for covering a wound to form a wound cavity; providing an aspirant conduit having one end thereof operably associated with the wound cavity; providing vacuum means provided at a distal end of the aspirant conduit for applying a vacuum to the wound cavity; and, air bleed means in fluid communication with the wound cavity.

15

In order that the present invention may be more fully understood, examples will now be described by way of illustration only with reference to the accompanying drawings, of which:

- 20 Figure 1 shows a schematic cross section through a wound to which TNP therapy is being applied and also showing schematically one embodiment of the present invention;

Figure 2 shows across section through a schematic embodiment of a sealing membrane having an air bleed conduit and filter therewith; and

25

Figure 3 shows a perspective view of a grommet for use in apparatus employing some embodiments of the present invention;

- 30 Figures 4A to 4D which show various views of an embodiment of an air bleed port for attachment to a sealing membrane;

Figure 5 shows a schematic cross section through a second wound having an alternative air bleed port member attached to the sealing membrane;

- 35 Figures 6A to 6D show various views and a cross section s of the air bleed port shown in Figure 5;

Figures 7A to 7D show various views and a cross section of a further alternative air bleed port for use with the dressing shown in Figure 5;

- 5 Figures 8A to 8D show various views and a cross section through an alternative air bleed port suitable for the dressing shown in Figure 1; and

Figures 9A and 9B which show a cross section and plan view, respectively of a further embodiment of a port member according to the present invention.

10

Referring now to the drawings and where the same features are designated by common reference numerals.

Figure 1 shows a schematic cross section through a wound 10 to which is applied
15 apparatus 12 according to the present invention for administering TNP therapy to the wound. The wound 10 has a sealing membrane 14 covering it and sealed to sound flesh 16 around the border of the wound so as to define a wound cavity 17. An aspirant conduit 18 is provided, the conduit having a perforated drain portion 20 and a single lumen portion 22 attached thereto and which is sealed to the dressing at 24 where it
20 passes through. The distal end of the conduit 18 is connected to a suitable vacuum pump 26. The dressing is provided with a second, short conduit portion 30 which accesses the wound cavity 17 through the membrane 14 and sealed thereto at 32. The conduit 30 is provided with a pinch clamp 34 which enables the soft plastics material of the conduit 30 to be either closed or open for flow. At the end of the conduit 30 is a small
25 plastics material housing 36 having an air inlet 38 an air outlet 40 and in between a filter element 42. Thus, air entering the inlet 38 must flow through the filter element 42 in order to flow through the outlet 40 and through the conduit 30. Optionally, there may be a layer of porous, compression resistant wound filler (not shown) adjacent the wound surface 10 to prevent the sealing membrane 14 from being pulled down onto the wound
30 surface by the applied vacuum and thereby preventing flow of wound exudate to the aspirant drain conduit portion 20 from the whole area of the wound. However, in Fig 1 which is meant to represent a small area wound such a wound filler may not be necessary if the sealing membrane is sufficiently taught not to contact the wound surface under the applied vacuum..

35

In operation the vacuum pump is turned on and a vacuum is created in the wound cavity 17. If the wound cavity is well sealed with no or very little leakage, wound exudate fluid may not be transported along the conduit portion 22 to a waste receptacle (not shown) associated with the vacuum pump 26 since there is little or no air/fluid flow along the conduit 22. In this event the pinch clamp 34 may be opened so that an air bleed is admitted through the filter element 42 into the wound cavity 17 thus stimulating a fluid flow through the wound cavity 17 and through the conduit 22 towards the pump 26 so keeping the conduit 22 unblocked and free flowing. The pinch clamp 34 has no effect on the flow rate of the air bleed, merely controlling whether there is or is not flow through the conduit 30, all flow control being decided by the pore size and area of the filter element 42.

In this instance the filter 42 is a 0.2 micron pore size, antimicrobial filter

The pinch clamp may be left open so that the conduit 30 is permanently open in the event that the wound cavity is particularly well sealed so providing a constant air bleed whilst the vacuum pump 26 is running.

Figure 2 shows a schematic cross section of a dressing 100 for use with the apparatus according to the present invention and comprises a sealing membrane portion 102 and a conduit portion 104 having a filter housing 106 and having a filter 108 therein. The dressing 100 may be manufactured as an entity, the conduit portion 104 being attached by an adhesive layer 112 to a membrane member 114 at a flange portion 110 associated with the conduit portion 104. The lower face 116 of the adhesive layer 112 is protected in known manner by a layer of protective siliconised paper 118. In this dressing portion the membrane 114 covers the wound being adhered to sound flesh at the border thereof by the adhesive layer 112. The conduit 104 may optionally be provided with a pinch clamp, for example, as in the embodiment shown in Figure 1 and for the same purpose.

Figure 3 shows a conduit 200 of the type shown in Figures 1 and 2 but plugged into a grommet member 202. The grommet member has two curved faces 204, 206 which meet at tapered edges 208, 210. This assembly of conduit 200 and grommet is incorporated into a dressing by the grommet member being sandwiched between two layers 212, 214 of thin, flexible adhesively coated membrane material where adhesive coated faces of the membrane material (not shown) face each other and adhere to the faces 204, 206

as discussed in our co-pending International patent application, PCT/US2007/074374, mentioned above and of common ownership herewith. Other embodiments of grommets from PCT/US2007/074374 may also be utilised.

5 Figure 4 shows various views of an air bleed port member 300 for attachment to a sealing membrane (not shown). Figure 4A shows a cross section through the port member; Figure 4B shows a plan view of the port member; Figure 4C shows a view in elevation; and, Figure 4D shows a perspective view of the port member 300. The port member 300 comprises a moulded body portion 302 having a centrally disposed
10 aperture 304 therethrough; an upper cap portion 306 having air ports 308 therethrough; and, a filter element member 310 sandwiched between the body portion and the cap portion. The cap portion 306 also has a circular recess 312 in fluid communication with the air ports 308, the filter element 310 being exposed to the area of the recess 312. The bottom face 314 of the body portion has a layer of adhesive 316 thereon and which is
15 protected prior to use with protective paper layer 318 which is removed before use by means of a protruding finger tab 320.

To use the air bleed port member, a hole (not shown) is made in the membrane (not shown) covering the wound commensurate with the size of the aperture 304, the
20 protective paper layer 318 is removed and the air bleed port 300 adhered to the upper surface of the sealing membrane with the hole in the membrane and the aperture 304 in communication with each other.

In a preferred construction the air bleed port 300 may be provided as part of a dressing
25 membrane with the port 300 and membrane adhered or welded (in the latter case there is no adhesive layer 316) together during manufacture.

Figure 5 shows a wound 500 having therein a porous, resiliently compressible wound filling element 502 such as a polyurethane foam material, for example, cut to conform
30 generally to the wound shape and size. The wound 500 is covered with a self-adhesive flexible sealing membrane 504 similar to that shown in Figure 1 and which is adhered to sound flesh 506 surrounding the wound 500. The membrane 504 has an aperture 508 formed therein and over which is adhered an air bleed port 510. The port 510 has a domed shape 512 having an aperture 514 in a flanged base portion 516, the aperture
35 514 being made coincident with the aperture 508 in the membrane 504. The port 510 has a socket portion 520 to receive an aspirant conduit 522 which is connected to a

vacuum pump 524 and an intervening waste canister (not shown). The socket portion 520 receives the end of the aspirant conduit 522 to an extent which leaves uncovered an air bleed hole 528 which has a surrounding recess 530 into which is adhered a filter element 532. The wound surface 500, membrane 504 and air bleed port 510 form
5 between them a sealed cavity 534.

In operation the vacuum pump 524 generates a predetermined vacuum level in the cavity 534 which causes the membrane 504 to be pushed down onto the porous, resiliently compressible wound filling element 502 by the ambient excess air pressure and the apertures 508, 514 to come into direct contact with the top surface of the resiliently compressible foam material 502 thus aspirating wound exudate which permeates through the wound filling element 502 to the waste canister (not shown). Whilst the wound exudate is being aspirated, the air bleed hole 528 and filter 532 permit a continuous controlled rate air bleed into the conduit 522 preventing the aspiration of
10 wound exudate from stagnating. If, for any reason, it is desired to stop the air bleed then this can be terminated by the simple expedient of placing a piece of non-porous adhesive tape over the hole and filter 532.
15

Figure 6 shows the air bleed port 510 of Fig. 5. Fig. 6A shows a top plan view of the port; Fig. 6B shows a cross section on the line 6B-6B of Fig. 6A; Fig. 6C shows a view looking in the direction of arrow 6B on the left of Fig. 6A; and Fig. 6D shows a side view in elevation. The air bleed port 510 is generally of domed circular form having a hollow domed portion 512 and a socket portion 520 having a passage 540 leading into the hollow portion 542. The port comprises a flat flange portion 516 having an adhesive layer 544 to adhere to a flexible sealing membrane and the adhesive layer being
20 protected before use by a layer of siliconised paper (not shown) in known manner. The lower face of the flange portion 516 has an aperture 514 therein exposing the hollow portion 542. The socket portion receives an aspirant conduit, in use, as described with reference to Fig. 5 and also has an air bleed hole 528 lying in the centre of recessed portion 530 which receives a filter member as shown in Fig. 5. The pore size of the filter member and, to an extent the size of the hole 528 control the rate of air bleed into the aspirant conduit at the desired pressure in the wound cavity 534 (see Fig. 5). The port 510 may be moulded from a soft plastics material such as polyurethane or polypropylene, for example.
30

The port described with reference to Fig. 6 may be adhered to a sealing membrane as described above or adhered or welded thereto in a pre-prepared sealing membrane and port unit.

- 5 An important advantage of the port according to the embodiment of Fig. 6 is that it is particularly easy to apply to a wound in that the self adhesive membrane material merely needs adhering to sound flesh after first having placed a wound filling element in the wound, an aperture made in the membrane and the port adhered thereto (or a pre formed port/membrane applied to the wound and an aspirant conduit plugged into the
10 socket portion 520. There is no need to seal the aspirant conduit to the sealing membrane and the number of steps for making a TNP therapy dressing is significantly reduced.

Figure 7 shows an air bleed port 600 which may also be used with the dressing
15 described with reference to Fig. 5. Fig. 7A shows a top plan view of the port; Fig. 7B shows a cross section on the line 7B-7B of Fig. 7A; Fig 7C shows a side view in elevation of the port of Fig. 7A; Fig. 7D shows an underside plan view of the port of Fig. 7A; Fig. 7E shows a perspective view of the port; and, Fig. 7F shows a view of the port in the direction of arrow 7B on the left of Fig.7A. The port 600 is of generally circular
20 form having a flange portion 602, a shallow domed body portion 604 lying within the flange periphery and a socket portion 606. The shallow domed body portion 604 is not hollow but has a number of splayed unequal length finger-like indentations 608 formed in the upper surface thereof as an aid to stiffness. The indentations extend almost through the thickness of the domed portion save for a predetermined thickness of material 610
25 remaining on the underside. On the underside the spaces between the indentations create a space 612 in which vacuum may exist and wound exudate collect to be aspirated away by an associated aspirant conduit (not shown) connected to the socket portion 606 in the same manner as with the port of Fig. 6. The socket portion 606 has a passage 614 therethrough leading to an aperture 616 which connects with a co-
30 operating aperture, in use, in a sealing membrane. The socket portion has an air bleed hole 620 and a recessed portion 622 to receive a filter element (not shown) in the same manner as the port of Fig. 6. As with Fig. 6, the aspirant conduit is only inserted into the passage 614 up to the air bleed hole 620 so as not to block it.

- 35 This port also adheres to the sealing membrane surface or may be pre-prepared by adhering or welding the port thereto as a unit. Where the port member 600 has a layer

of adhesive on the underside of flange portion 602 it may be provided with a protector layer of siliconised paper or PE film (not shown) to be removed by the user immediately before application to a flexible sealing membrane (not shown).

- 5 In use the port of Fig. 7 operates in the same manner as the port of Fig. 6 whereby the vacuum in the wound cavity cause the sealing membrane and port to be pushed down by excess ambient air pressure onto a porous and resiliently compressible wound filling element to provide a direct path for wound exudate to the aspirant conduit as shown and described with reference to Fig. 5.

10

Although resiliently compressible wound filling elements have been described above it is only necessary for the wound filling element to remain porous when the maximum desired vacuum is applied and it is not necessary that it also be resiliently compressible. The air bleed port of Fig. 7 has the same advantages as does the port of Figure 6.

15

- Figure 8 shows an air bleed port 700 which is generally suitable for use with the type of wound dressing as shown in Figure 1. Fig. 8A shows a perspective view of the port; Fig. 8B shows cross section in elevation of the port of Fig. 8A; Fig. 8C shows a view in elevation of the port of Fig. 8A along the line 8C; Fig.8 D shows a top plan view of the port of Fig. 8A; and, Fig.8E shows a cross section similar to that of Fig. 8B but with a portion of aspirant conduit inserted. The port 700 comprises an annular base flange portion 702 having a generally cylindrical wall portion 704 thereon. An angled tubular aspirant conduit receiving neck portion 706 supported on a bellows portion 708 is provided at the top of the wall portion 704. The wall portion 704 is provided with an air bleed hole 710 and a surrounding recess 712 to receive a filter element (not shown) as with other embodiments described above. The port 700 is moulded from a soft, flexible plastics material, the bellows portion 708 allowing the neck portion 706 to move and flex easily when an aspirant conduit 714 (see Fig. 8E) is in place. The port 700 may be used with the type of dressing shown in Fig. 1 where the aspirant conduit extends into the wound cavity 716 created between the wound bed and the sealing membrane 718. The end 720 of the conduit 714 may be associated with any desired item within the wound cavity such as a porous wound filling element whilst the other end 722 of the conduit 714 is connected to a waste canister and vacuum means (both not shown). The lower face 724 of the flange portion 702 is provided with an adhesive layer (not shown) to adhere to the sealing membrane 718 which has an aperture to coincide with an opening 730 in the
- 20
- 25
- 30
- 35

annular base portion 702. The tubular neck portion 706 has an internal diameter to seal with the outer surface of the aspirant conduit 714.

5 In operation the wound cavity is evacuated to a desired pressure via the conduit 714 whilst a small but continuous air bleed through the hole 710 and filter in the recess 712 prevents wound exudate from stagnating due to a no-flow condition in the aspirant conduit 714. The flexible bellows portion 708 maintains the conduit 714 spaced-apart from the air bleed hole 710 thus preventing the hole from becoming blocked by the conduit surface due to the vacuum in the wound cavity

10

As with previous embodiments the port 700 may be provided as a unit with a flexible sealing membrane by being adhered or welded thereto.

15 A further embodiment of an air bleed port member is shown in Figure 9. The air bleed port member 800 comprises a patch of filter membrane 802 shown in Fig. 9B as circular (although it does not need to be round and could, for example, be rectangular) and having an annular layer of adhesive 804 applied to the outer periphery thereof, the adhesive being protected prior to use by protector papers 806. The adhesive layer prevents air bleed through that portion of the element which is coated with the adhesive.

20 Therefore, by controlling the area of the filter membrane portion 810 coated with adhesive, the air bleed rate may be controlled through the uncoated portion 808 to an accurate level at a given pressure within a wound dressing. Thus, patches of filter membrane of a given size may be pre-coated with adhesive annuluses of varying widths or area allowing the user/clinician to choose the appropriate air bleed rate at the

25 intended pressure.

Air bleed ports may be sterile packaged having an air bleed rate and associated pressure or pressure range printed thereon.

30 The air bleed port member of Fig. 9 may alternatively be pre-adhered or welded to a larger substrate layer of flexible sealing membrane as with other embodiments described above.

35 In the case of the port of Fig.9 being welded to a flexible sealing membrane, the area of the filter membrane within the weld bead periphery would determine the air bleed flow rate. Thus, a range of air bleed port members welded to flexible sealing membranes may

be prepared having different air bleed flow rates, the flexible sealing membrane having an aperture formed therein below the filter membrane portion through which air bleed occurs. In the case of the port being welded to a flexible sealing membrane the adhesive layer outside of the weld periphery may or may not be present.

5

Throughout the description and claims of this specification, the words “comprise” and “contain” and variations of the words, for example “comprising” and “comprises”, means “including but not limited to”, and is not intended to (and does not) exclude other moieties, additives, components, integers or steps.

10

Throughout the description and claims of this specification, the singular encompasses the plural unless the context otherwise requires. In particular, where the indefinite article is used, the specification is to be understood as contemplating plurality as well as singularity, unless the context requires otherwise.

15

Features, integers, characteristics, compounds, chemical moieties or groups described in conjunction with a particular aspect, embodiment or example of the invention are to be understood to be applicable to any other aspect, embodiment or example described herein unless incompatible therewith.

20

CLAIMS:

1. An apparatus for the provision of topical negative pressure therapy to a wound, the apparatus comprising:
 - a sealing membrane for covering a wound to form a wound cavity;
 - a port configured to attach to an upper surface of the sealing membrane, the port comprising:
 - a flange portion having a lower surface provided with an adhesive thereon;
 - an aperture in the flange portion configured to communicate with the wound cavity through a hole formed in the sealing membrane when in use with the port attached to the upper surface of the sealing membrane and the sealing membrane covering the wound;
 - a body portion provided above the flange portion and above the aperture, the body portion defining a space in which vacuum may exist; and
 - an air bleed provided in a surface of the body portion along a passage within the port that extends substantially parallel to the lower surface of the flange portion in a lateral direction, the air bleed positioned at a location laterally offset from the aperture, wherein the air bleed further comprises a filter element;
 - an aspirant conduit having one end thereof connectable with the port at a location laterally spaced from the air bleed and capable of being operably associated, in use, with the wound cavity; and
 - a vacuum source for applying a vacuum through the aspirant conduit to the wound cavity when in use.
2. An apparatus according to claim 1, wherein the air bleed is switchable between an on and an off position.
3. An apparatus according to claim 1, wherein the air bleed comprises a second conduit having one end in communication with the wound cavity in use, the air bleed being in communication with a distal end of the second conduit.
4. An apparatus according to claim 3, wherein the apparatus comprises an on/off clamp or valve in communication with the aspirant conduit.

5. An apparatus according to claim 1, wherein the port is attached to the sealing membrane over the hole.
6. An apparatus according to claim 5, wherein the flange portion is substantially sealed to the sealing membrane via the adhesive.
7. An apparatus according to claim 1, wherein the filter element is microbial.
8. An apparatus according to claim 1, wherein a flow rate of air through the air bleed is less than 0.5 l/min.
9. An apparatus according to claim 8, wherein the air bleed flow rate is less than 0.2 l/min.
10. An apparatus according to claim 8, wherein the flow rate is less than 0.05 l/min
11. An apparatus according to claim 1, wherein the port has provision to receive the aspirant conduit.
12. An apparatus according to claim 11, wherein the aspirant conduit is configured to extend through the port member into the wound cavity.
13. An apparatus according to claim 11, wherein the aspirant conduit terminates at the port whilst permitting an air bleed into the wound cavity, in use.
14. An apparatus according to claim 1, wherein the aspirant conduit extends away from the port in a direction substantially parallel to the lower surface of the flange portion when connected to the port.
15. An apparatus according to claim 1, wherein the air bleed and the filter element are provided in an upper surface of the body portion and along the passage within the port that extends substantially parallel to the lower surface of the flange portion, such that, when in use, the air bleed and filter member are downward facing.

16. An apparatus according to claim 1, wherein the port comprises an air bleed hole at which the filter element is adhered.
17. An apparatus according to claim 16, wherein the air bleed hole comprises a surrounding recess into which the filter element is adhered.
18. An apparatus according to claim 1, wherein the port is manufactured from a soft plastic material.
19. An apparatus according to claim 1, further comprising a layer of paper or film configured to protect the adhesive.
20. An apparatus according to claim 1, further comprising a layer of paper configured to protect the adhesive and a tab to aid in removal of the paper layer prior to use of the port.
21. An apparatus according to claim 1, wherein the sealing membrane and port are manufactured separately and the flange portion of the port is adapted to be substantially sealed to the sealing membrane via the adhesive.
22. An apparatus according to claim 1, wherein the passageway within the port forms a first fluid passage and the air bleed comprises a second fluid passage in fluid communication with the first fluid passage.
23. An apparatus according to claim 1, wherein the flange portion is flat.
24. An apparatus according to claim 1, wherein the port further comprises a socket portion configured to receive a distal end of an aspirant conduit, wherein the socket portion receives the distal end to an extent which leaves the air bleed uncovered.
25. An apparatus according to claim 1, wherein the filter element is substantially flat.

26. An apparatus according to claim 25, wherein the air bleed is located at a substantially flat portion of the surface of the body portion.

27. An air bleed port member for a topical negative pressure dressing for communicating with a sealed cavity in use, the port member comprising:

- a base portion comprising a flange portion, the flange portion having a lower surface configured to be applied in a substantially parallel direction relative to the dressing and an aperture in the flange portion, wherein the lower surface of the flange portion has adhesive thereon for attaching the base portion to an upper surface of the dressing and the aperture is configured to communicate with the wound cavity through a hole formed in the dressing when in use;

- a body portion provided above the base portion and aperture defining a space in which vacuum may exist and wound exudate may be collected to be aspirated away;

- a socket portion for connecting to an aspirant conduit;

- an air bleed configured to bleed air into the sealed wound cavity, the air bleed provided in a surface of the body portion and positioned between the socket portion and the aperture; and

- a filter element provided to cover the air bleed.

28. A port member according to claim 27, wherein the flange portion is adapted to be substantially sealed to a flexible sealing membrane in a dressing via the adhesive.

29. A port member according to claim 27, wherein the socket portion is configured to have the aspirant conduit either terminate at the socket portion or pass completely through the socket portion.

30. A port member according to claim 27, wherein the aperture is configured, in use, to directly receive aspirated wound exudate.

31. A port member according to claim 27, wherein the socket portion is configured to connect the aspirant conduit so that the aspirant conduit extends away from the socket portion in a direction substantially parallel to the lower surface of the flange portion.

32. A port member according to claim 31, wherein the aspirant conduit and the port member are manufactured as a single entity.
33. A port member according to claim 27, wherein the body portion defines a passage extending laterally away from the aperture.
34. A port member according to claim 33, wherein the air bleed and filter are located along the passage laterally spaced from the aperture.
35. A port member according to claim 34, wherein the air bleed and filter are in an upper surface of the body portion and are downward facing.
36. A port member according to claim 27, wherein the port is manufactured from a soft plastic material.
37. A port member according to claim 27, further comprising a layer of paper or film configured to protect the adhesive.
38. A port member according to claim 27, further comprising a layer of paper configured to protect the adhesive and a tab to aid in removal of the paper layer prior to use of the port.
39. A use of the apparatus defined in any one of claims 1 to 26 for providing topical negative pressure therapy to a wound.
40. A use of the air bleed port member defined in any one of claims 27 to 38 in a dressing for providing topical negative pressure therapy to a wound.
41. A port member for use with a topical negative pressure dressing for communicating with a wound cavity in use, the port member comprising:
 - a base portion provided with an adhesive thereon, the adhesive configured to attach the base portion of the port member to an upper surface of a sealing membrane of the topical negative pressure dressing;

an aperture in the base portion configured to communicate with the wound cavity through a hole formed in the sealing membrane when in use with the port member attached to the upper surface of the sealing membrane and the sealing membrane covering the wound cavity;

a passage within the port member that extends substantially parallel to the base portion, wherein a width of the passage is smaller than an outer dimension of the base portion; and

an air bleed configured to bleed air into the wound cavity, the air bleed comprising an air inlet positioned at a location laterally offset from the aperture.

42. The port member of claim 41, further comprising a body portion provided above the base portion and above the aperture, the body portion defining a space in which vacuum may exist.

43. The port member of claim 42, wherein the body portion has a domed shape.

44. The port member of claim 41, wherein the air bleed comprises a conduit having a first end in communication with the wound cavity in use and a second end spaced away from the wound cavity.

45. The port member of claim 41, wherein the air bleed comprises an air bleed passage having a first end in communication with the passage within the port member and a second end spaced away from the passage.

46. The port member of claim 41, wherein the air inlet is provided in an upper portion of the port member.

47. The port member of claim 41, wherein the air bleed comprises a filter element positioned at the air inlet.

48. The port member of claim 47, wherein the filter element is positioned beneath an upper portion of the port member.

49. The port member of claim 41, further comprising a connector portion configured to connect the passage to an aspirant conduit.

50. The port member of claim 49, further comprising an aspirant conduit having a proximal end thereof connectable with the port member via the connector portion and a distal end configured to be in fluid communication with a vacuum source for applying a vacuum through the aspirant conduit to the wound cavity when in use.

51. The port member of claim 50, wherein the aspirant conduit extends away from the port member in a direction substantially parallel to the base portion when connected to the port member.

52. The port member of claim 41, wherein the port member is manufactured from a soft plastic material.

53. A port member for use with a topical negative pressure dressing for communicating with a wound cavity in use, the port member comprising:

- a base portion configured to be applied in a substantially parallel direction relative to the topical negative pressure dressing, the base portion having an adhesive thereon for attaching the base portion to an upper surface of the dressing;

- an aperture in the base portion configured to communicate with the wound cavity through a hole formed in the dressing when in use;

- a raised portion formed above the aperture in the base portion defining a space in which vacuum may exist and wound exudate may be collected to be aspirated away;

- a passage within the raised portion that extends substantially parallel to the base portion, the passage having a proximal end located relatively closer to the aperture and a distal end located relatively farther away from the aperture;

- a connector portion at the distal end of the passage, the connector portion configured for connecting to an aspirant conduit; and

- an air bleed configured to bleed air into the wound cavity, the air bleed comprising an air inlet positioned between the connector portion and the aperture.

54. The port member of claim 53, further comprising a filter element provided to cover the air inlet.

55. The port member of claim 54, wherein the filter element is positioned beneath an upper portion of the port member.

56. The port member of claim 53, wherein the air bleed comprises an air bleed passage having a first end in communication with the passage and a second end spaced away from the passage.

57. The port member of claim 53, wherein the connector portion is configured to connect the aspirant conduit so that the aspirant conduit extends away from the connector portion in a direction substantially parallel to the base portion.

58. The port member of claim 53, wherein the passage extends laterally away from the aperture in the substantially parallel direction relative to the topical negative pressure dressing.

59. The port member of claim 53, wherein the air inlet is laterally spaced from the aperture.

60. The port member of claim 53, further comprising a paper layer or film layer configured to protect the adhesive.

61. The port member of claim 53, wherein the base portion and the raised portion are manufactured from a soft plastic material.

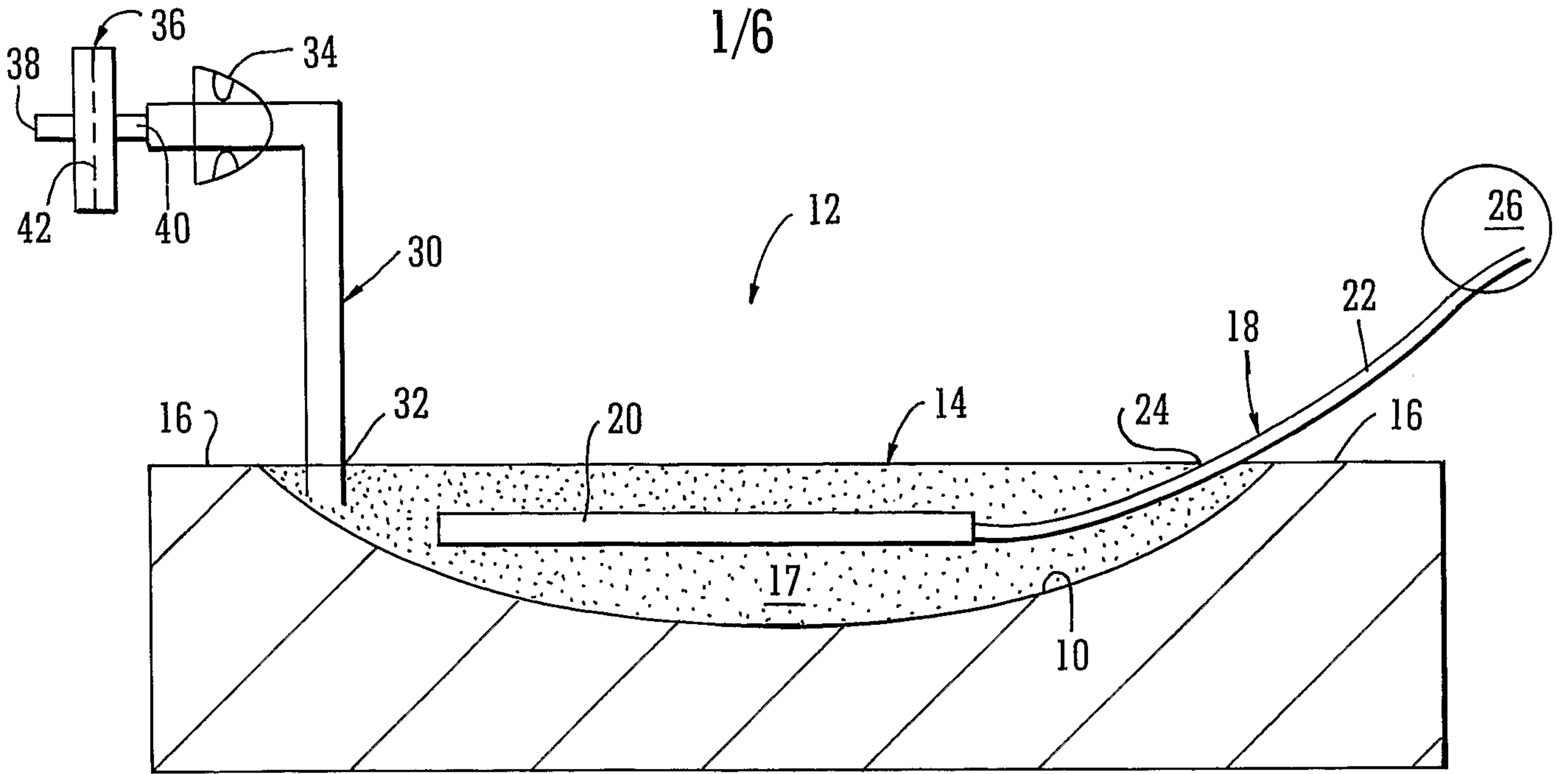

FIG. 1

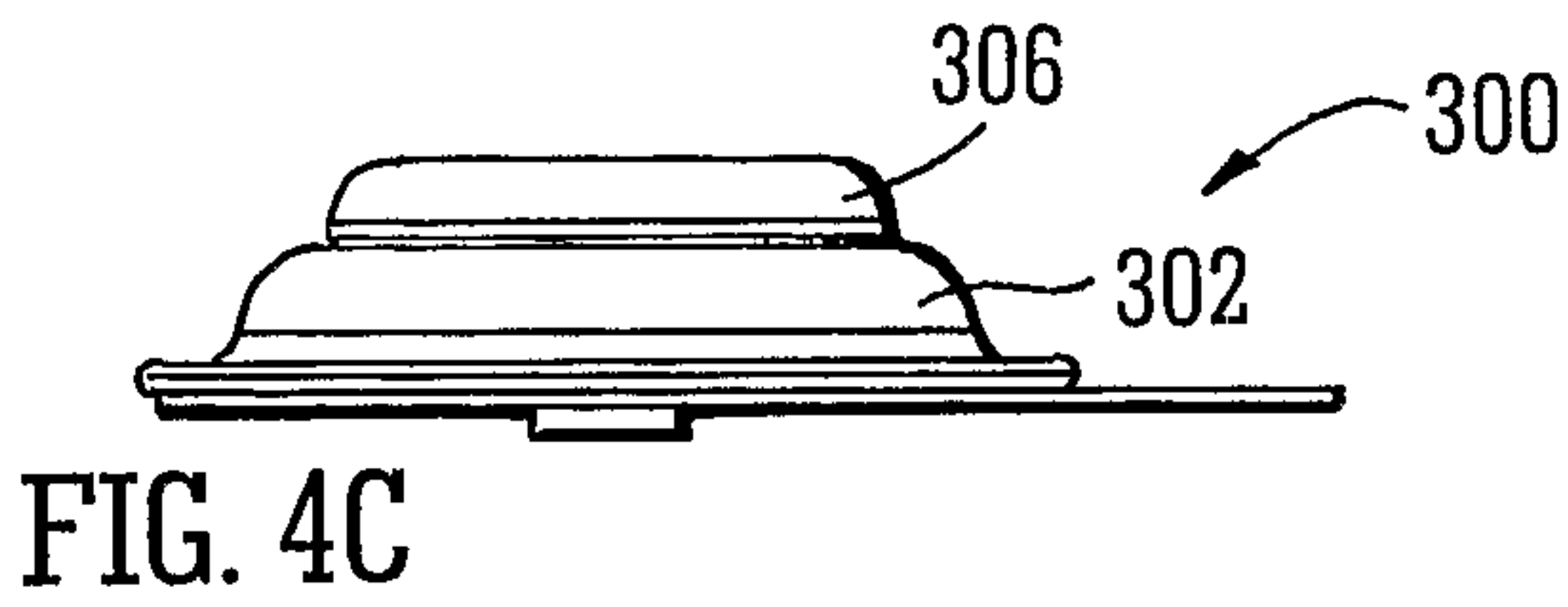

FIG. 4C

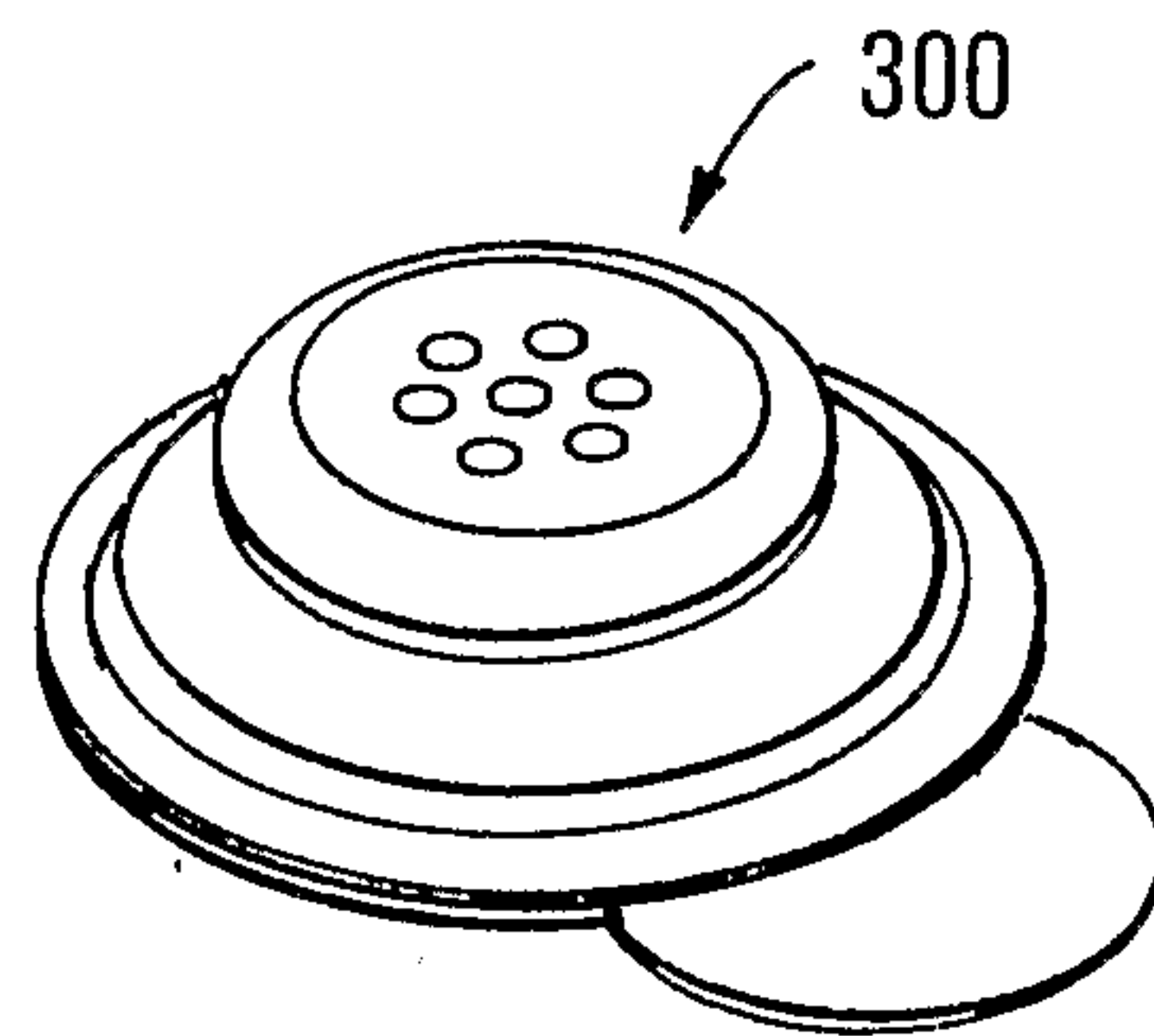

FIG. 4D

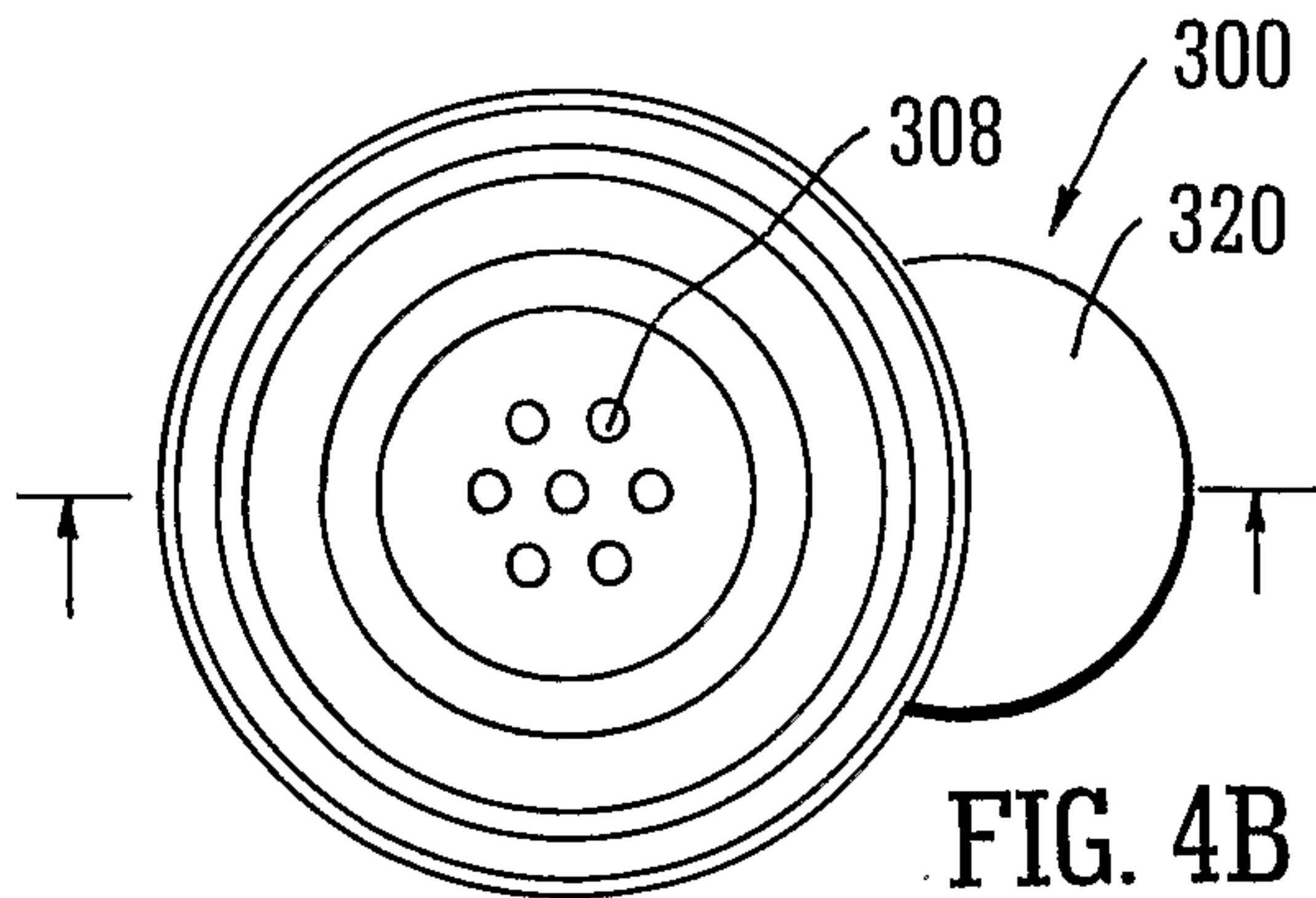

FIG. 4B

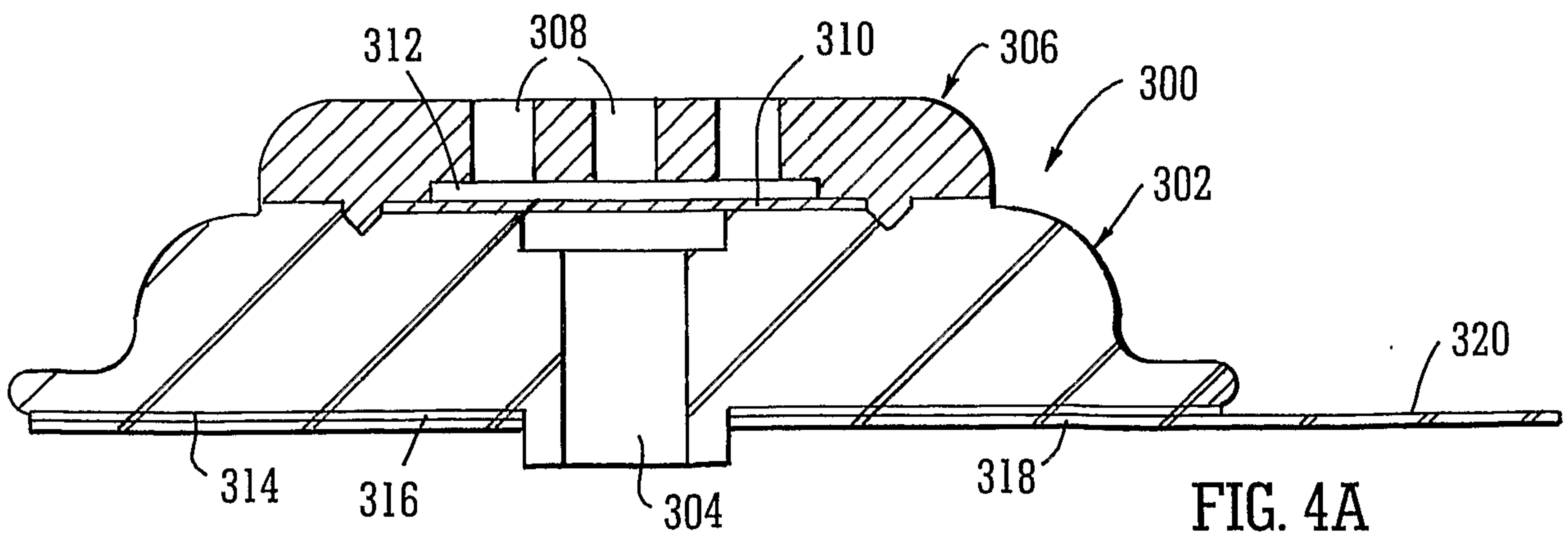

FIG. 4A

2/6

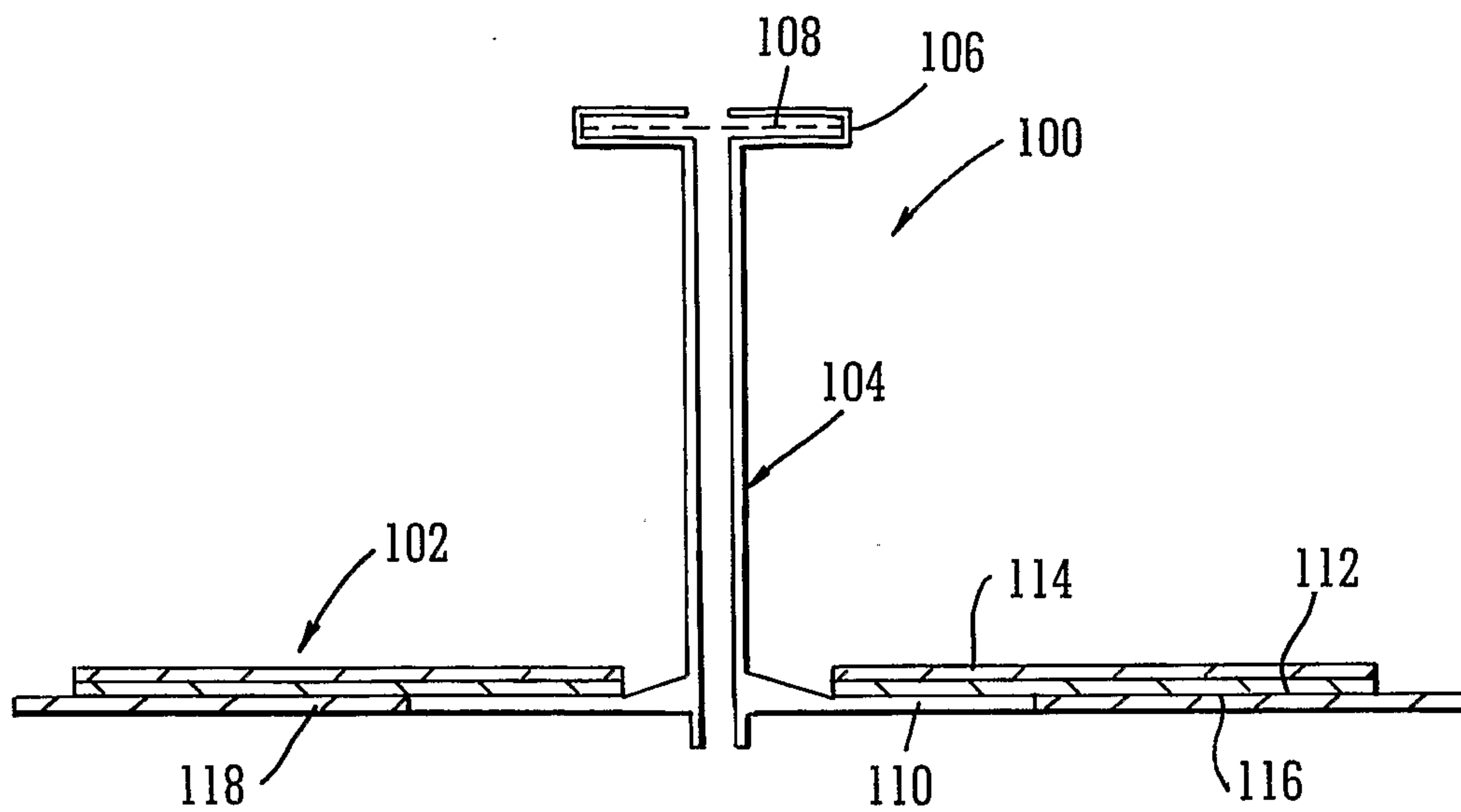

FIG. 2

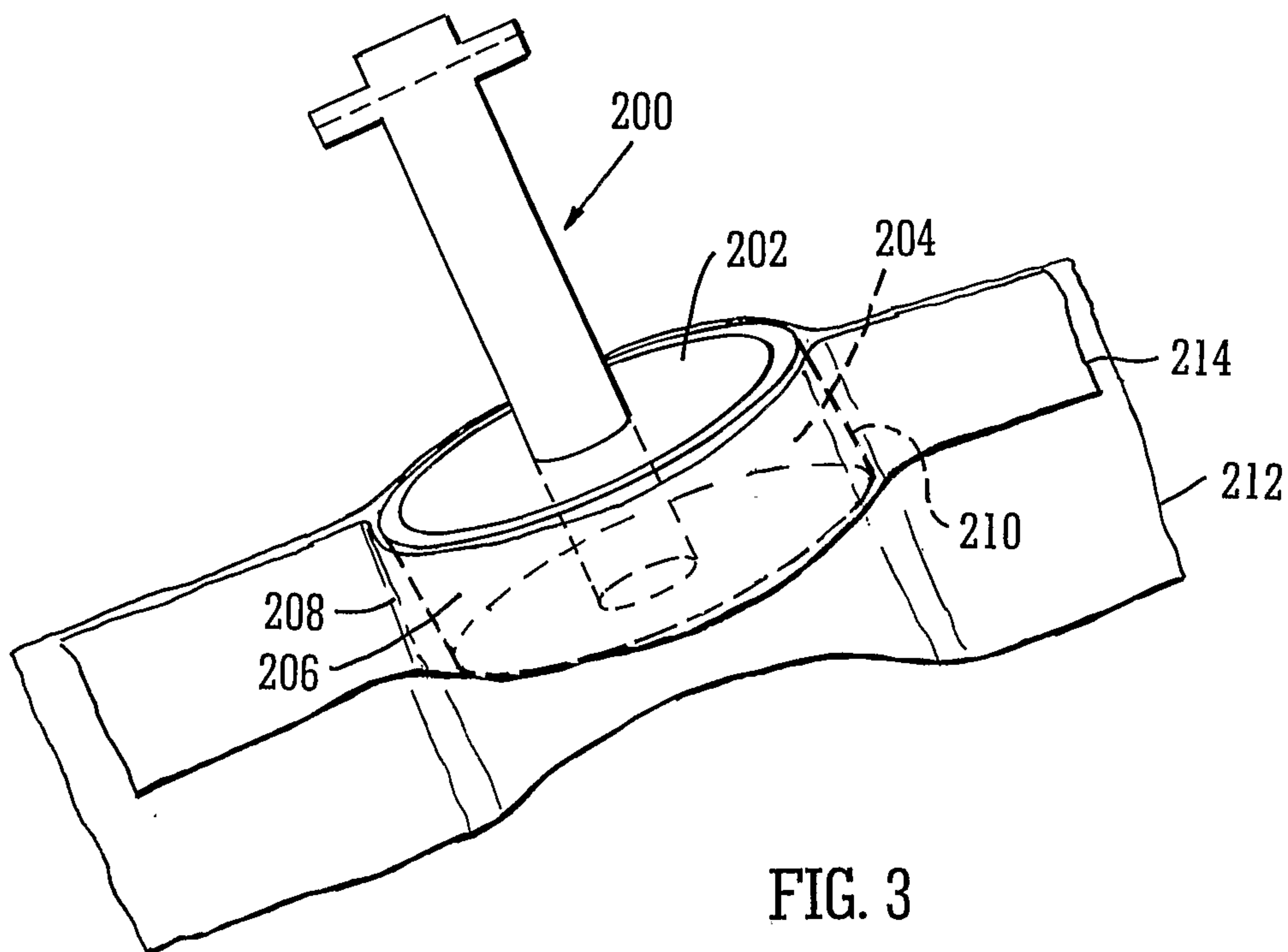

FIG. 3

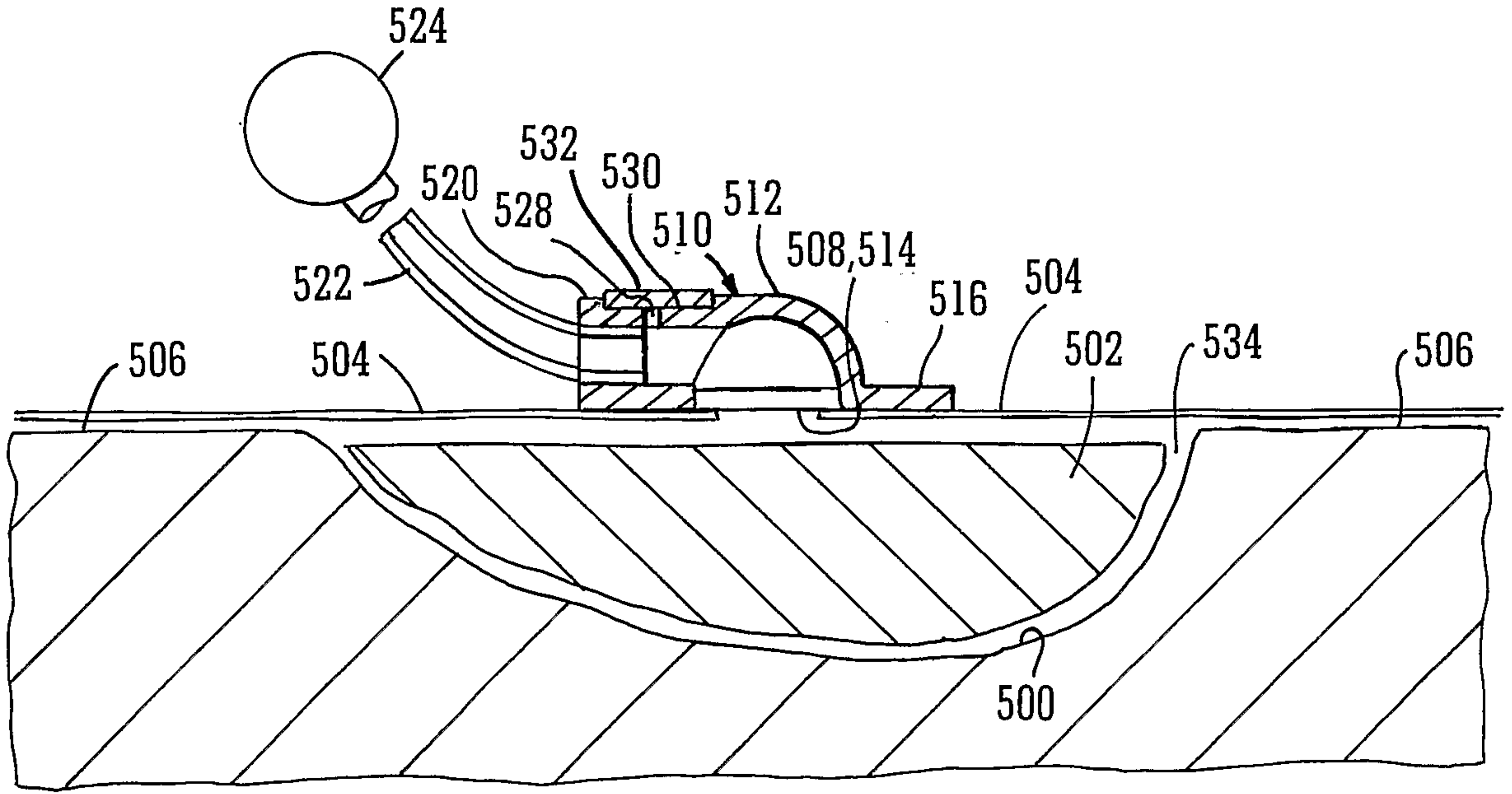

FIG. 5

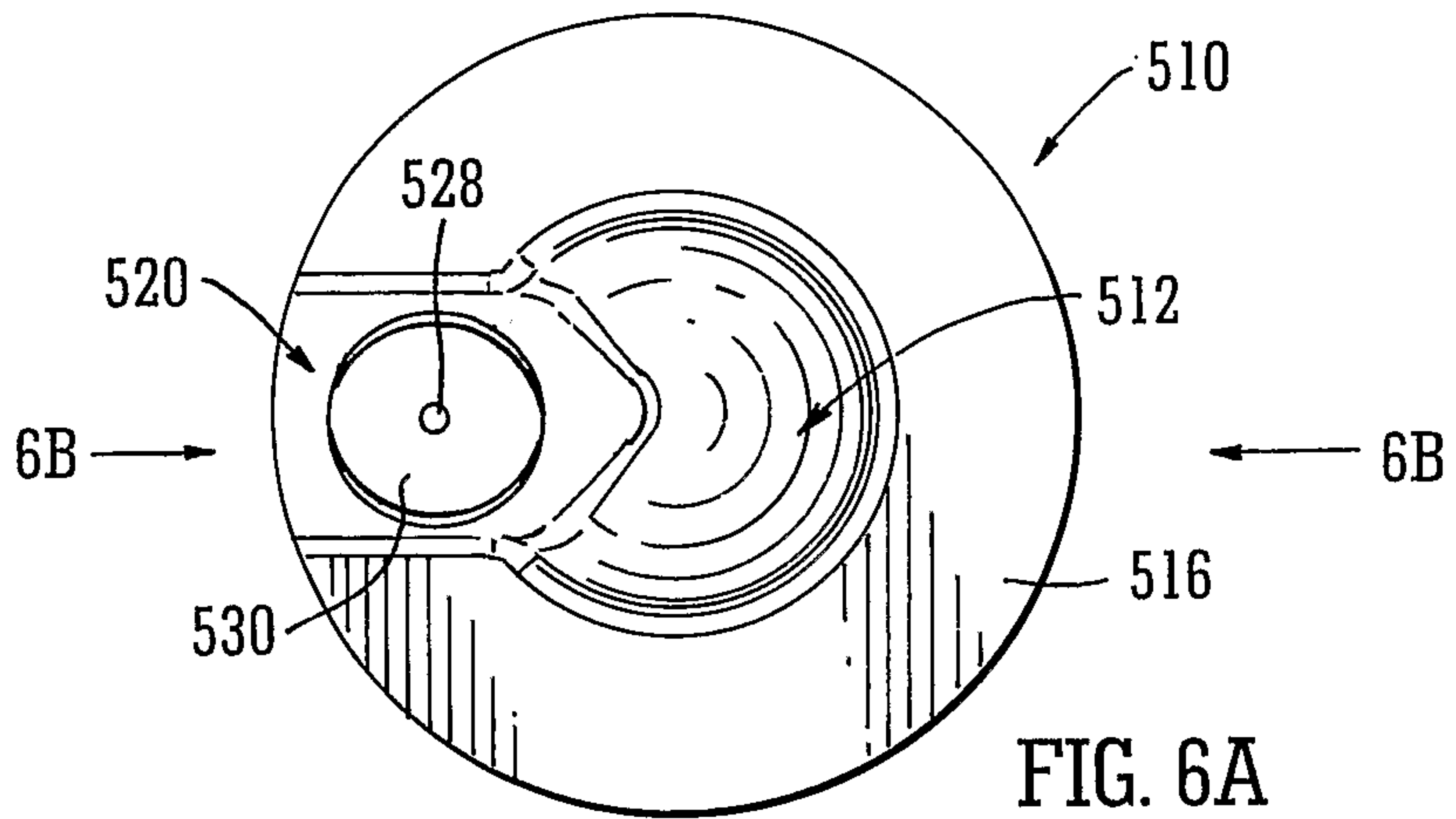

FIG. 6A

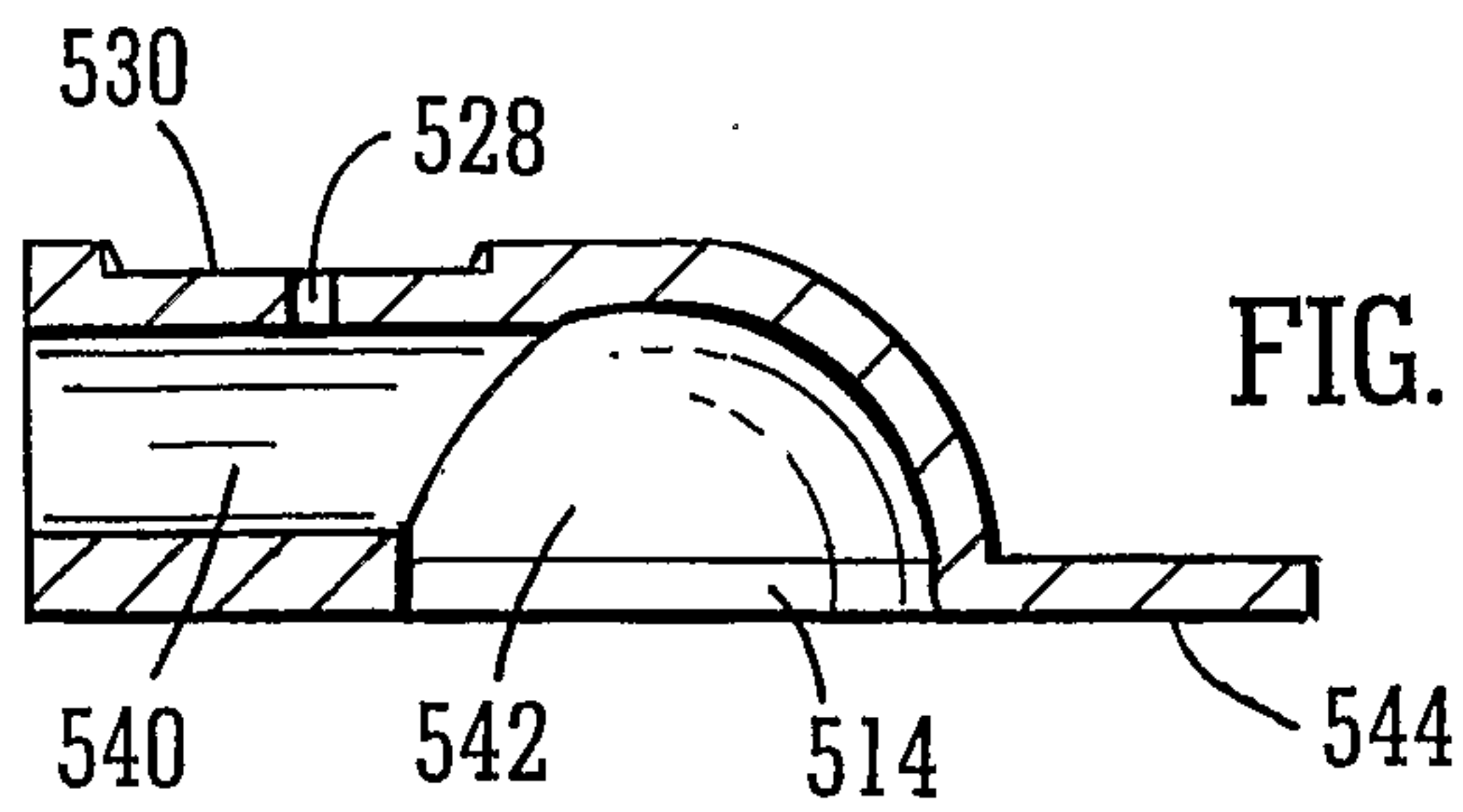

FIG. 6B

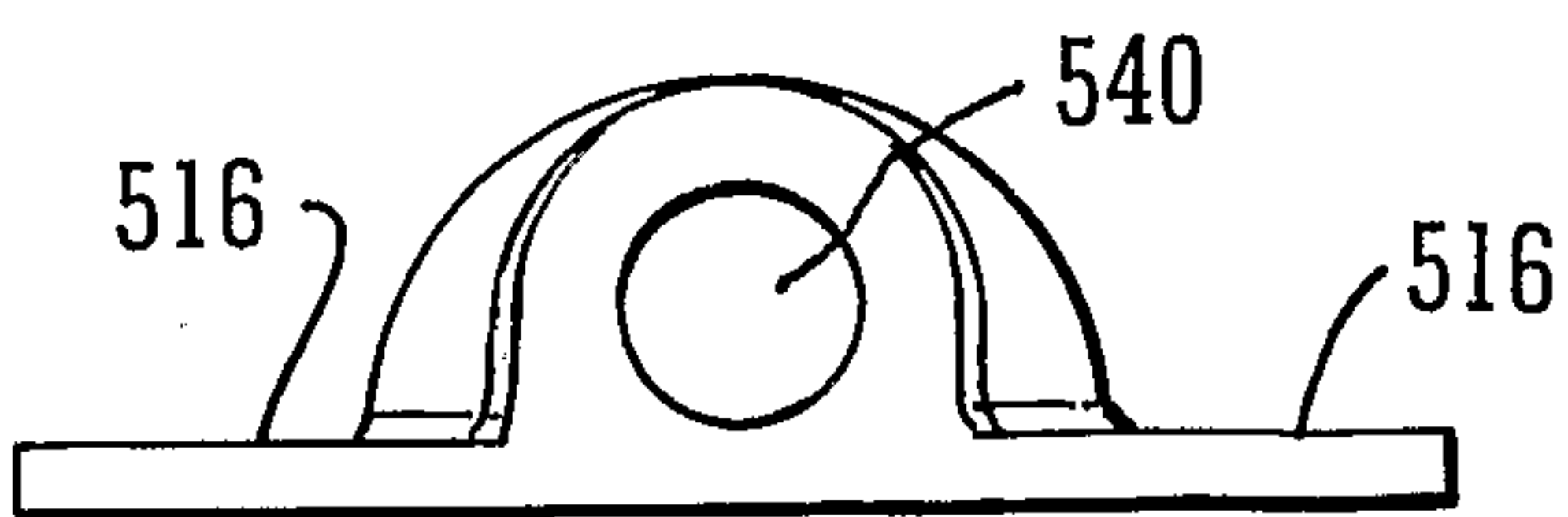

FIG. 6C

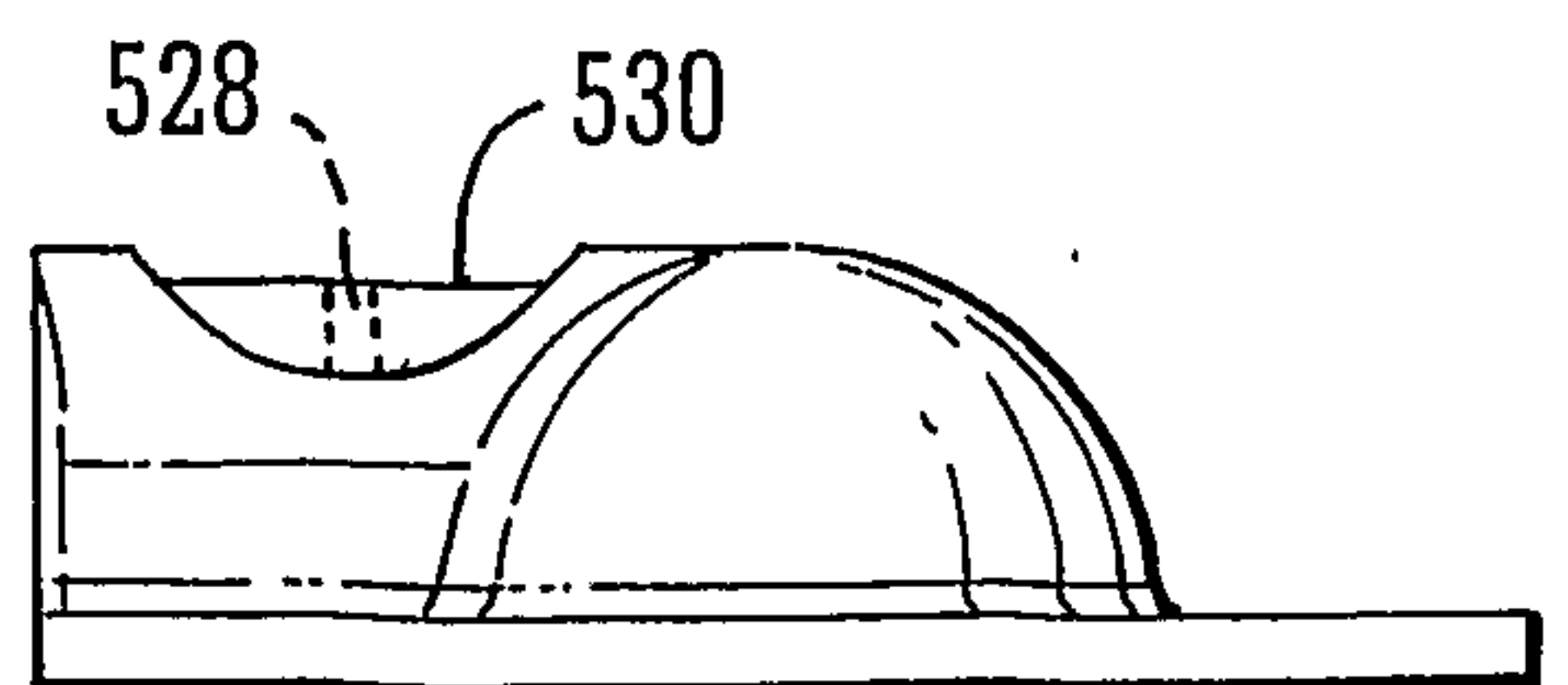

FIG. 6D

4/6

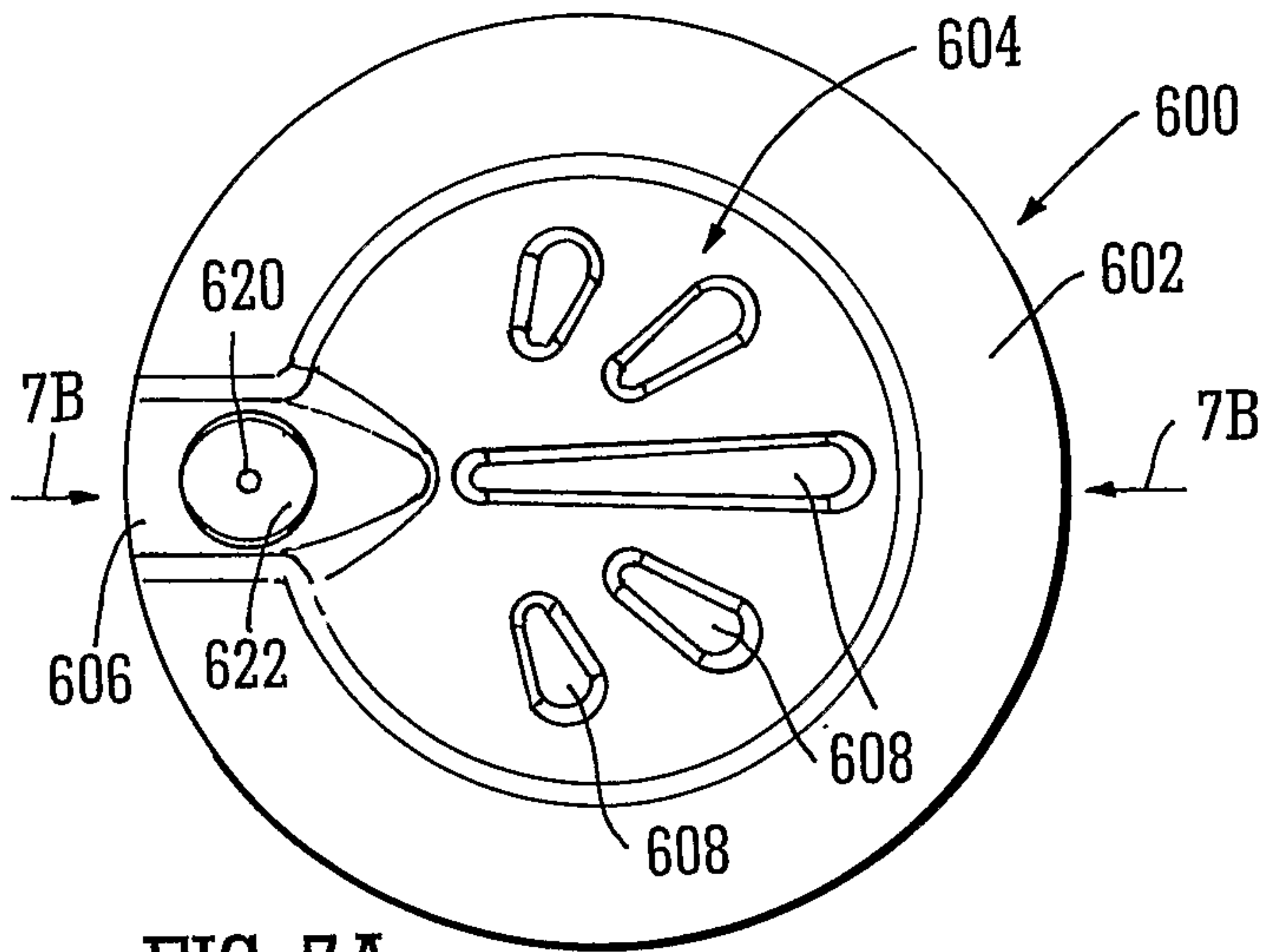

FIG. 7A

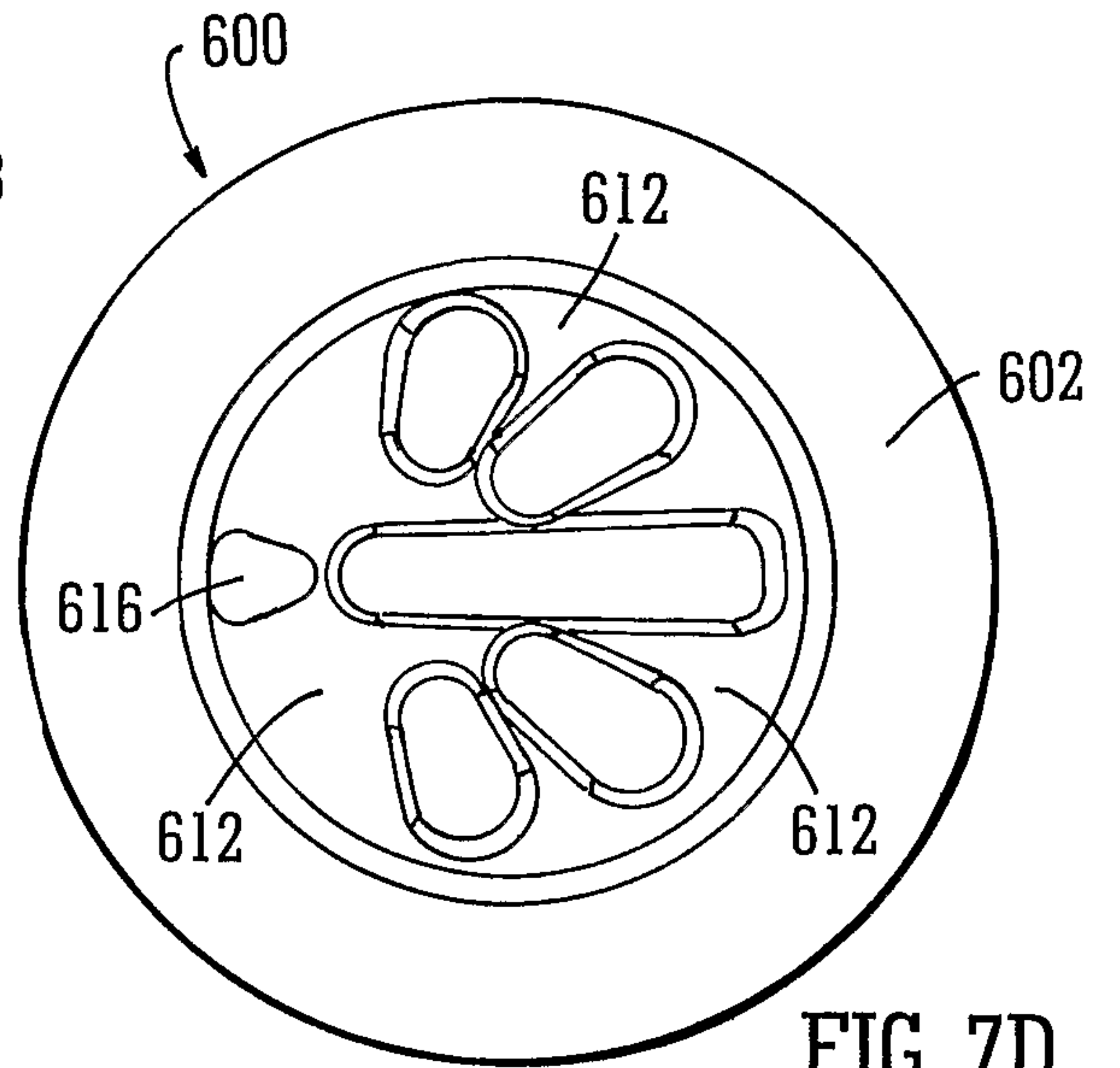

FIG. 7D

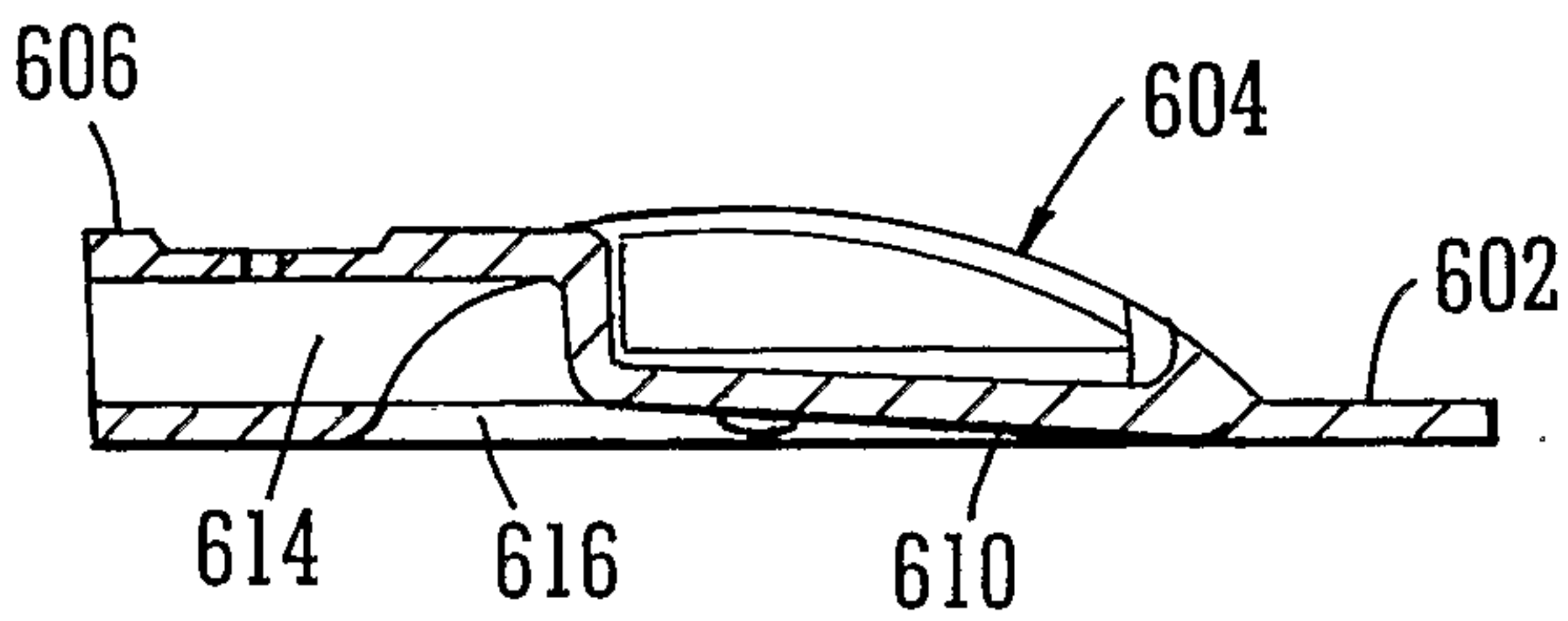

FIG. 7B

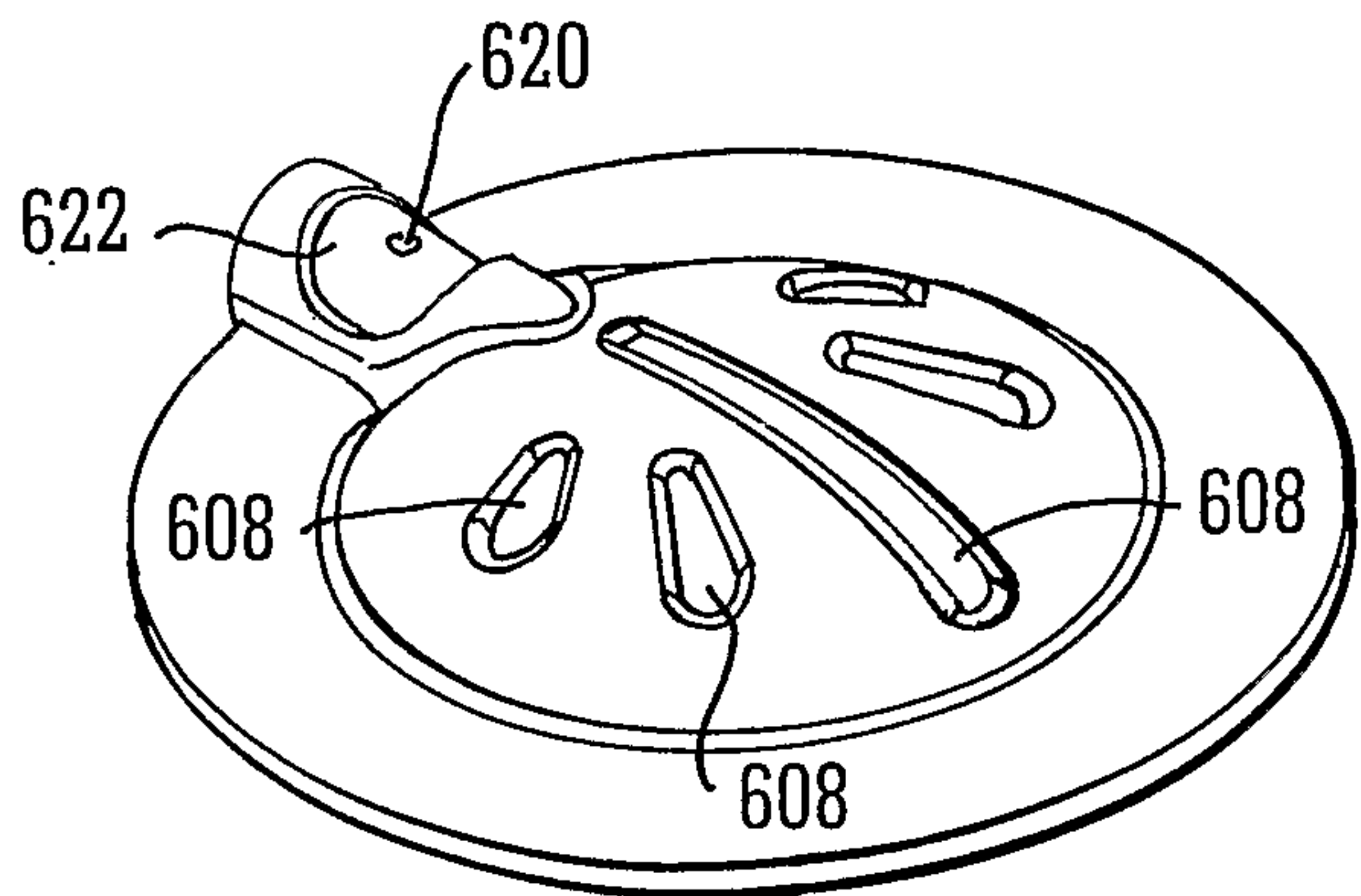

FIG. 7E

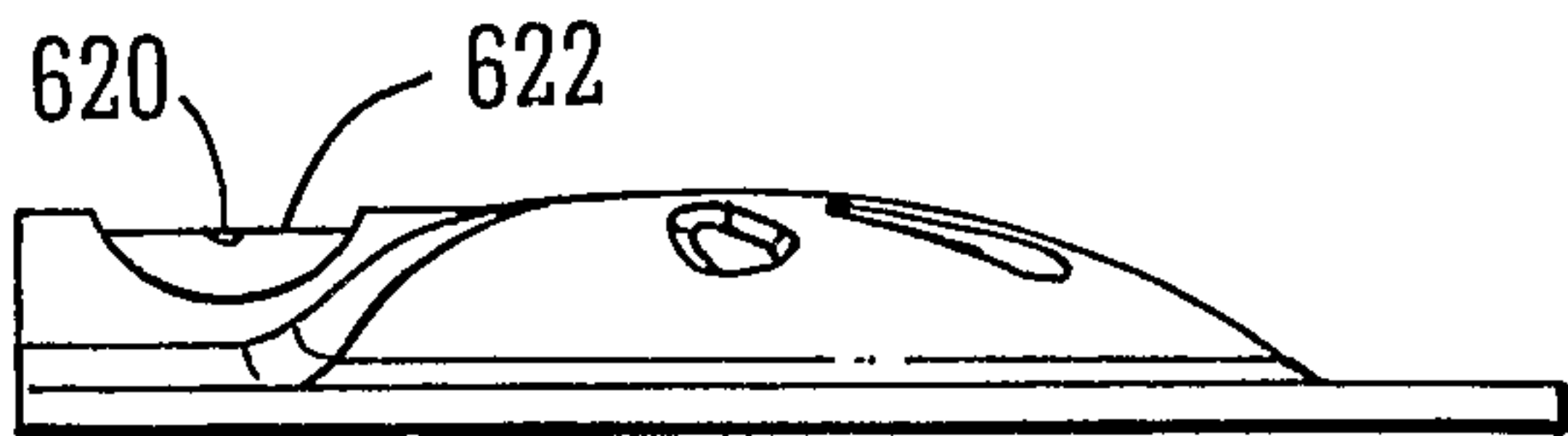

FIG. 7C

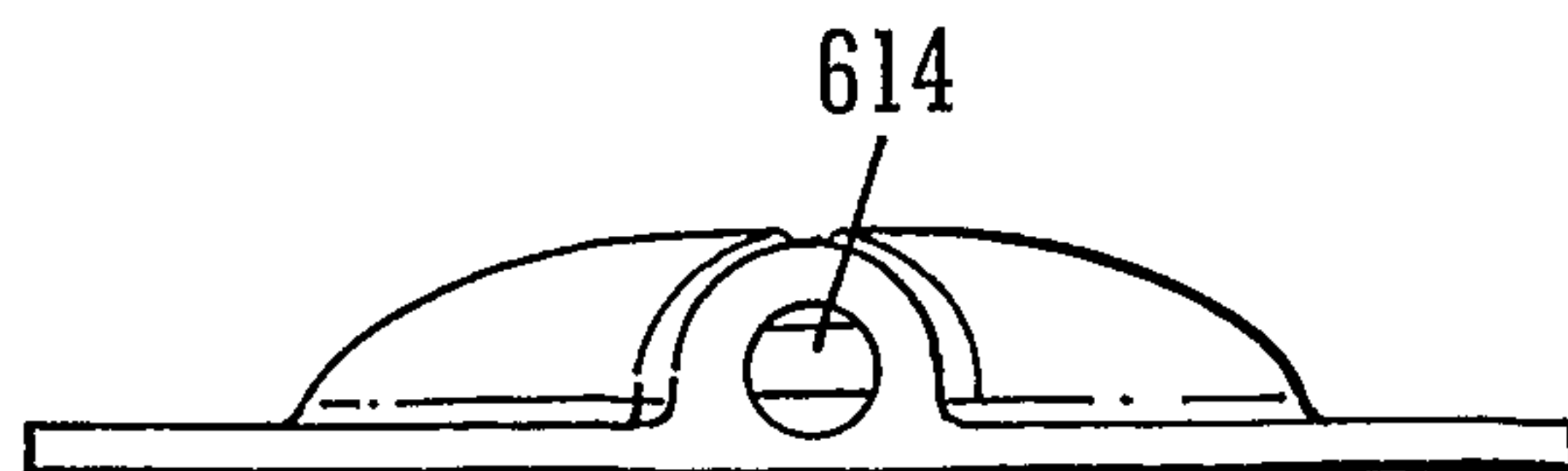

FIG. 7F

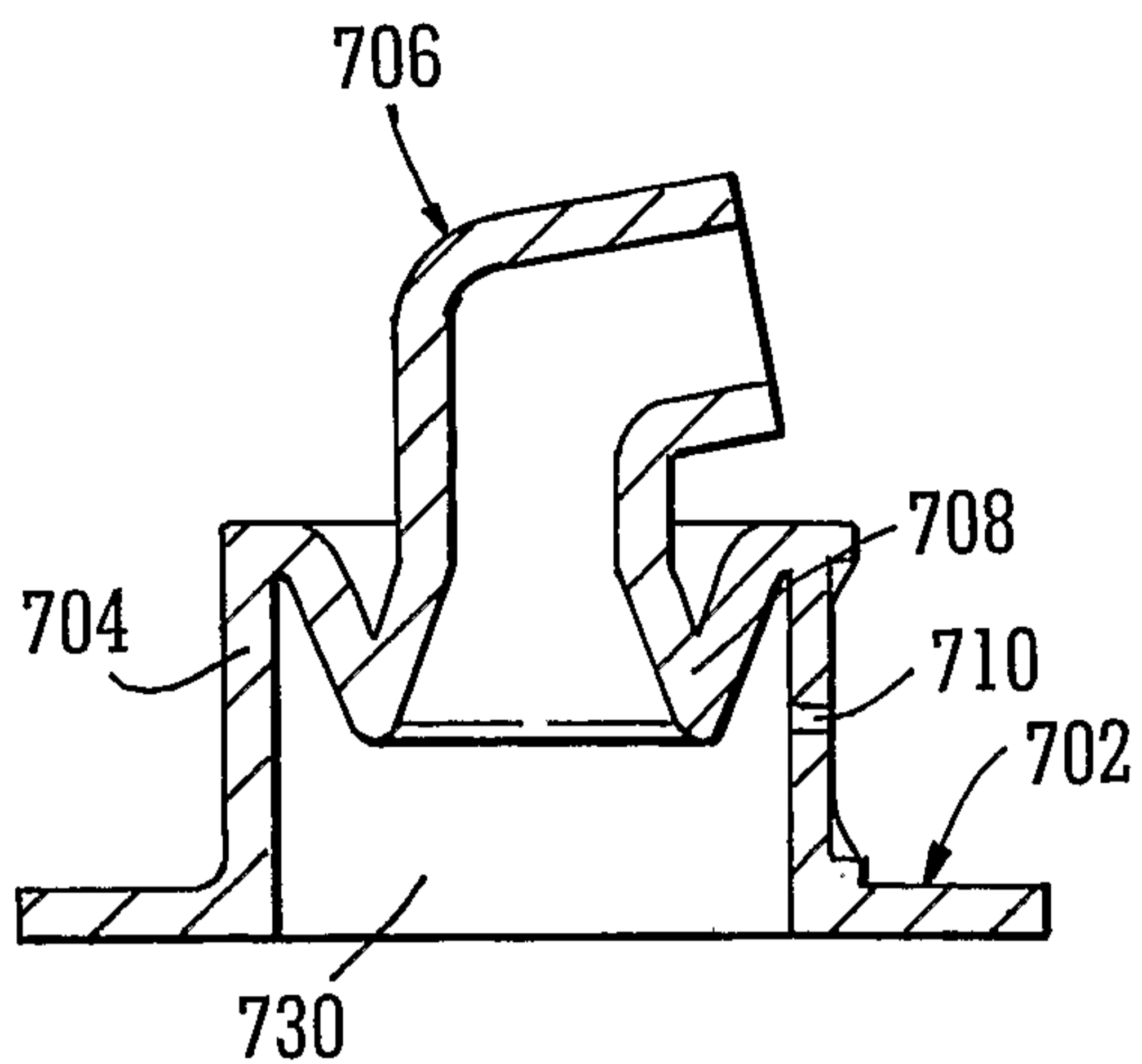

FIG. 8A

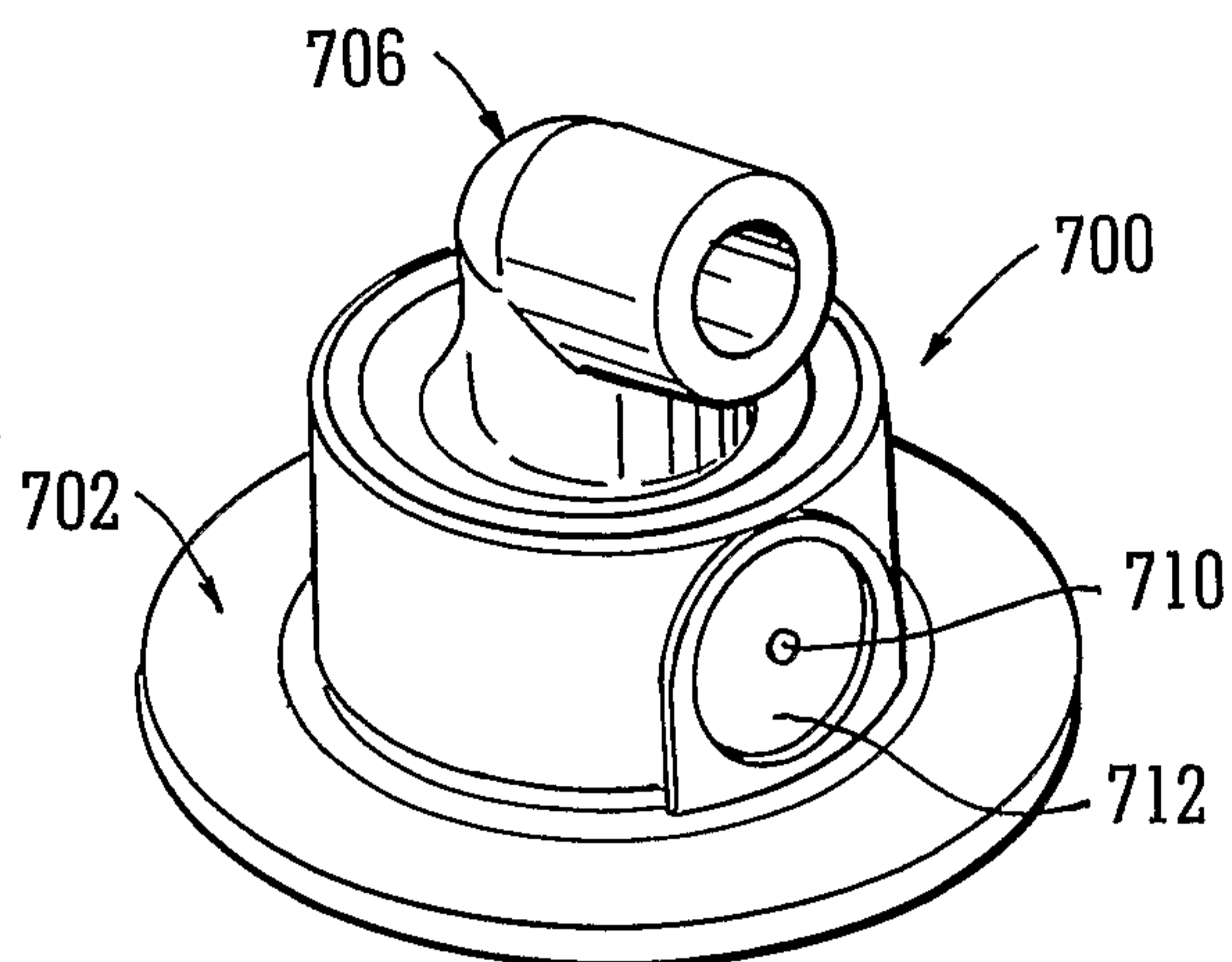

FIG. 8B

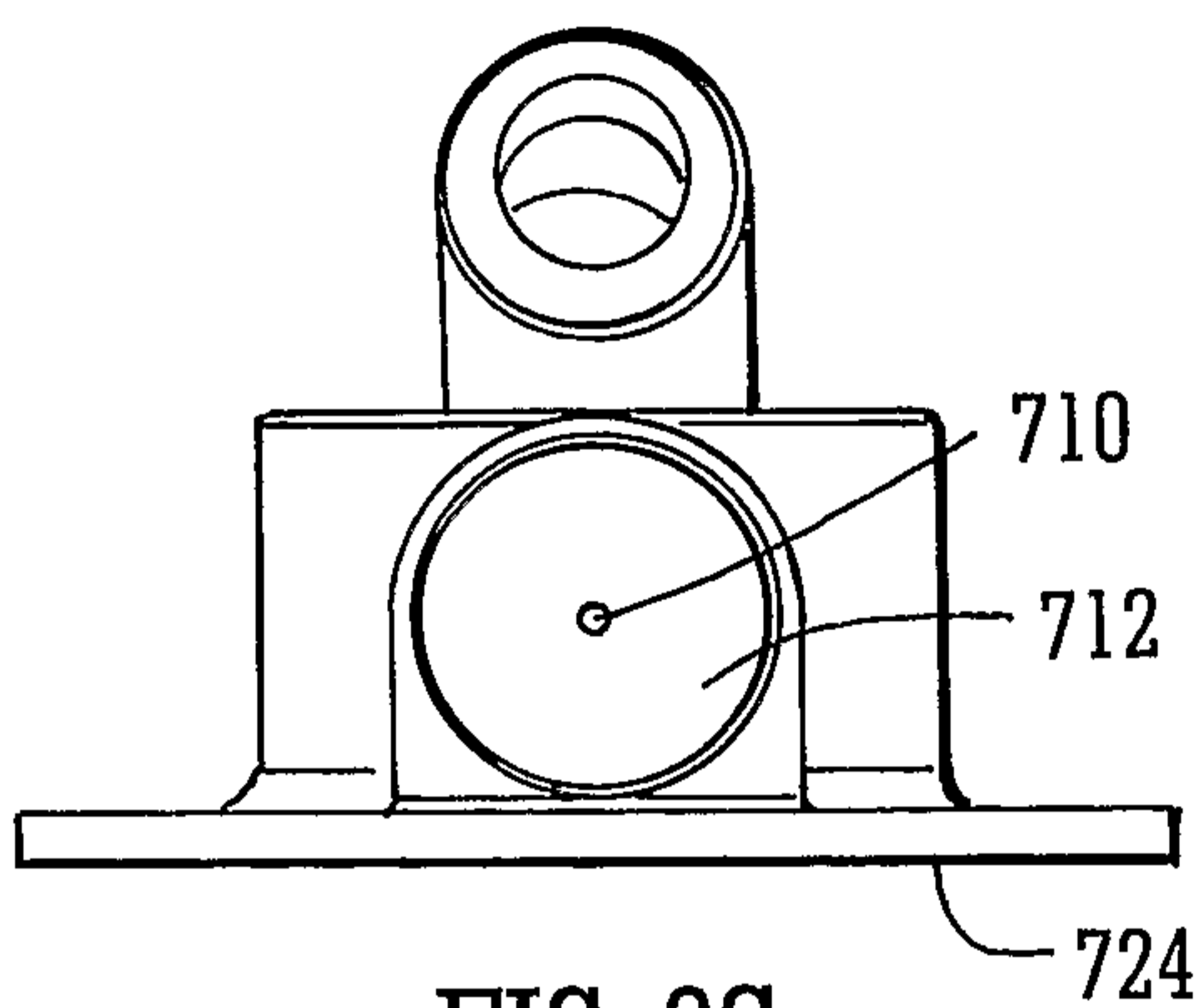

FIG. 8C

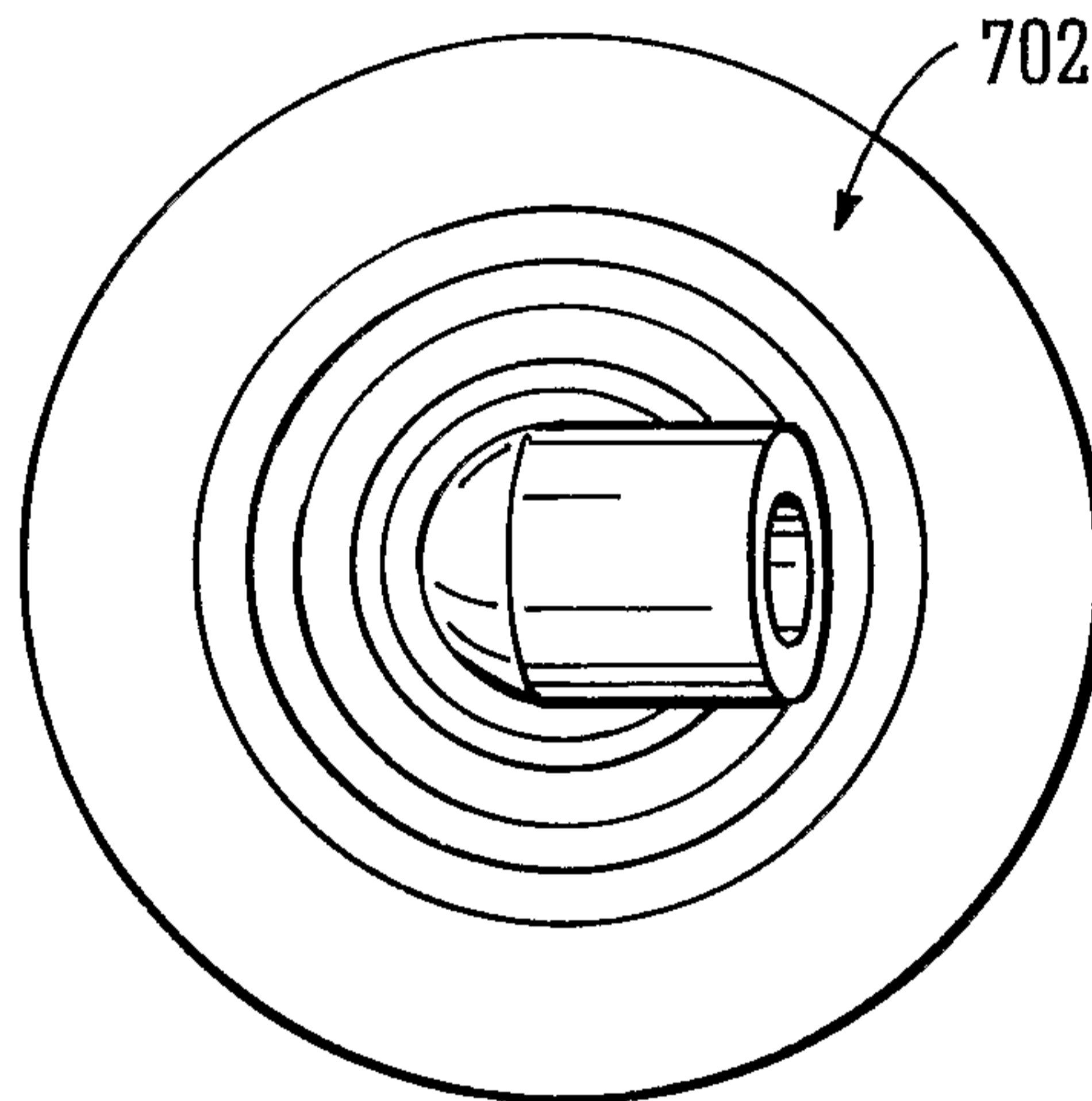

FIG. 8D

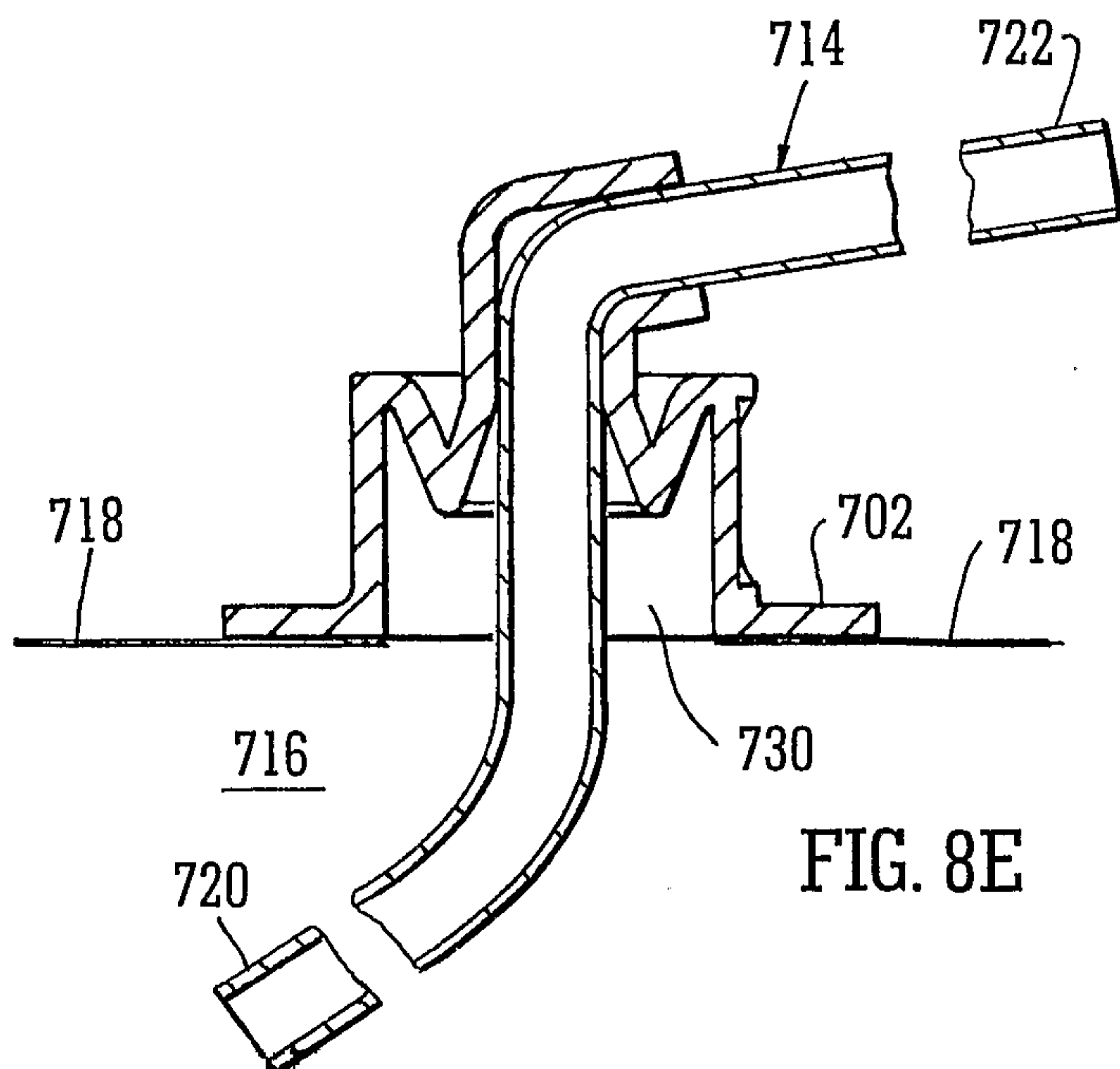

FIG. 8E

