

⑫ **EUROPEAN PATENT APPLICATION**

⑲ Application number: 84300545.5

⑥ Int. Cl.<sup>3</sup>: **E 04 G 1/06**

⑳ Date of filing: 30.01.84

⑳ Priority: 29.01.83 GB 8302514  
16.12.83 GB 8333595

⑦ Applicant: **PONABLE LIMITED, 29 Plascom Road, Wolverhampton West Midlands WV1 2DQ (GB)**

④③ Date of publication of application: 05.09.84  
Bulletin 84/36

⑦② Inventor: **Stuart, James Edwin Derek, 11A Mount Road Penn, Wolverhampton West Midlands (GB)**  
Inventor: **Gower, Victor William, 29 Plascom Road, Wolverhampton West Midlands WV1 2DQ (GB)**

④④ Designated Contracting States: **AT BE CH DE FR IT LI LU NL SE**

⑦④ Representative: **Spruce, George Philip et al, George Fuery & Co. Whitehall Chambers 23 Colmore Row, Birmingham B3 BL2 (GB)**

⑤④ **Dismountable framework.**

⑤⑦ Dismountable multi-purpose framework (for example for use in forming access towers or platforms) is provided using a set of elongate members, preferably metal angle; including pillar members (10) and linking members e. g. horizontal members (11) interconnected by engaging a tenon formation (12) at one end of a first pillar member with a socket formation (16) of a second pillar member so that they are aligned in end to end relationship. The linking members have apertured lugs (21) which engage the tenon formation between the pillar members and the assembly is secured by a U bolt (17) which engages the tenon formation and is tightened by a wedge (19).

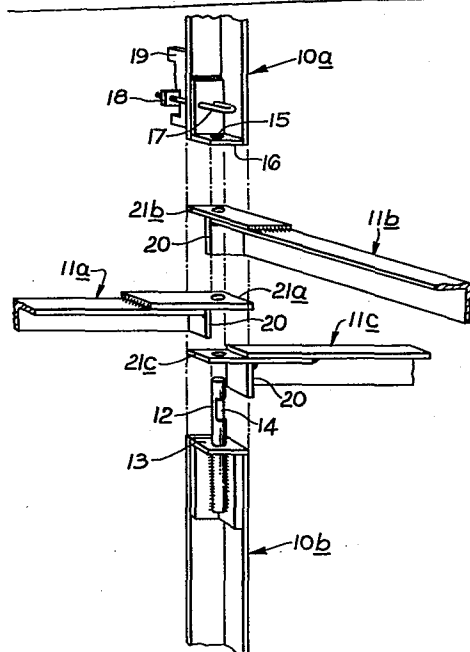

**EP 0 117 643 A2**

DISMOUNTABLE FRAMEWORK

This invention relates to dismantable frameworks which may be used for a wide range of purposes in forming temporary semi-permanent and/or readily dismantable structures, particularly but not  
5 exclusively scaffolding, access towers or platforms, temporary load supports e.g. for locating concrete shuttering or other falsework used in building, constructing temporary buildings or shelters,  
10 collapsible freight containers and stillages, and the like.

In the past round section steel scaffold tubing has been almost universally employed for such purposes as the above, particularly by commercial  
15 contractors and, though in many respects this material has proved satisfactory, it does have practical disadvantages. The tubing is costly; it is heavy unwieldy and difficult to store, transport and handle particularly for small scale applications e.g. domestic use, and in large  
20 scale applications such as substantial scaffolding erections, it is not always safe and secure as joining is normally effected by clamps in frictional engagement with the tubing periphery. Insufficient tightening or failure of even a single clamp,  
25 which may be under considerable loading, can cause a chain reaction leading to collapse of the entire structure, particularly as the tubing is not normally joined in end to end relationship i.e. each joint forms a side by side connection  
30 with forces transmitted in shear through the clamp and bending and/or twisting moments being carried by the tubing.

The object of the present invention is to provide a dismantable framework which is easily

in a range of sizes including those suitable for domestic or "do it yourself" users and which can be transported and stored in a minimum of space, and which is particularly reliable and safe in use.

According to the invention there is provided a set of members for constructing a dismountable framework comprising a plurality of operatively vertical elongate pillar members and a plurality of elongate linking members, end portions of said members being operatively interconnected to form a framework, a first end portion of one pillar member having a longitudinally projecting tenon formation and a second end portion of another pillar member having a socket formation opening longitudinally thereof to receive said tenon formation so that said pillar members are operatively aligned in rectilinear end-to-end relationship; end portions of the linking members each including an apertured lug for engagement with said tenon between said end portions in use to locate the linking member whereby the latter member is located in a vertical plane which includes a common axis of both of said pillar members and said tenon formation.

Preferably the second end portion is provided with securing means comprising a retaining member displaceable laterally of said end portion to engage the periphery of the inserted tenon formation.

An embodiment of the invention with certain variations and modifications is now more particularly described with reference to the accompanying drawings, wherein:

Figure 1 is an exploded perspective view of part of a rectilinear framework;

Figure 2 is an elevation of an assembled joint

of the framework;

Figure 3 is a sectional plan view on line 3-3 of Figure 2;

Figure 4 is a perspective view of a modified form of wedge;

Figure 5 is a perspective view of an end portion of a further form of cross member;

Figure 6 is a perspective diagram of an access tower;

Figures 7, 8 and 9 are perspective diagrams of examples of other structures utilising the invention; and

Figures 10, 11, 12 and 13 are perspective views of respective additional members for use with the invention.

A set of members for constructing a light duty rectilinear framework for use as scaffolding or the like, will first be described. The dismantlable members in the example shown in Figures 1 to 3, are of two kinds; vertical or pillar members 10 and linking members in the form of horizontal or cross members 11, major elongate parts of all of which consist of standard L section steel angle and having means for interconnection at each end thereof. For light duty applications such as a small domestic access platform e.g. for use on a staircase or for constructing a work bench or the like each member can be an effective length of 75cm for ease of handling and storage and the angle section could be 2.5cm. Wider and heavier section may be used e.g. 40 mm angle section in 3 mm gauge metal for heavy duty frameworks and longer members may be employed in some circumstances.

In Figures 1 to 3 only the lower end of an upper pillar member 10a and the upper end of a lower such member 10b is shown together with one end only

of three cross members 11a, b, c to connect with the pillar members at right angles.

Each pillar member 10 has a first operatively upper end portion forming a male connection by having a longitudinally extending tenon 12 welded to a block or distance piece between the inner faces of the angle webs and projecting centrally through a square end abutment plate 13 which is also welded to said webs. In this example tenon 12 is a circular section steel peg having a flat or notch 14 on one side partway along its free length.

The second operatively lower end portion of each pillar member 10 forms a female connection including a mortice aperture 15, in this example a circular bore in the centre of a square end abutment plate 16 welded to the webs of the angle section.

The latter end portion is also provided with securing means comprising a stirrup member in the form of a U bolt 17 located in a pair of bores in one web of the angle so as to provide a loop within the angle which embraces tenon 12 when the latter is inserted into mortice 15. The outer ends of U bolt 17 mount a cross piece 18 permitting its effective length to be selectively adjusted and a captive wedge 19 acts between the outer face of the associated angle web and cross piece 18 to draw the U bolt 17 into tight positive engagement with the notch 14 of tenon 12 to secure the assembly.

In the above manner a pillar of any desired length can be built up using successive pillar members 10 and these are secured in aligned end-to-end relationship so that down thrust is transmitted directly along their length. It will be observed that the inherent

weight-bearing ability of a pillar so formed does not in any way depend on the security or clamping engagement of the securing means with the tenons 12, indeed for some applications securing means may not be necessary.

Each cross piece 11 is formed from angle generally as described with reference to members 10 and both end portions of each cross member comprise a welded on end abutment plate 20 and an apertured lug 21 projecting longitudinally beyond plate 20, this lug being welded to the upper horizontal web of the angle either below (21c) or above (21a, b) the latter.

Where cross members are to be joined to the assembled pillar their lugs 21 are positioned on tenon 12 in sequence e.g. as illustrated in Figures 1 to 3 where a three-way connection is shown, before the tenon is engaged with the next upper pillar member 10a.

The wedge 19 is formed from flat plate and, as best shown in Figure 2, has one edge cut out to form a notch between upper and lower end stops 30a, 30b which retain the wedge captive with the U bolt 17. An upper part of the notch includes an inclined edge face 31 enabling the U bolt to be tightened by driving the wedge downwards to react with cross piece 18, elongated slots 18a in the latter permitting it to tilt on bolt 17. The lower part of the notch is deeper and not inclined to permit maximum inward movement of the U bolt for freeing the tenon 12. In a modification shown in Figure 4 the end stops 30a, 30b are bridged by a bar 32 integral with or welded onto said stops, so strengthening the wedge and making its captive

retention on cross piece 18 more positive.

Wedge 19 is preferably distinctively coloured so that a very quick visual inspection of the assembled framework will show whether it has been tightened into place (or has become loosened or displaced in service). In any event the wedge will tend to drop to the secured position in use which will retain the tenon automatically even if the wedge has not been fully tightened and, as explained above, the integrity of the structure does not depend on this tightening, downward loading on the cross members 11 and/or upper pillar member 10a is transmitted directly to the top of pillar member 10b and lateral forces on the latter are transmitted from members 11 directly to the tenon 12, the securing means carries none of these forces.

Instead of the adjustable U bolts 17 a simple link or hook-shaped bar, or a screw clamp, could serve as a retaining member of the securing means, and it will also be appreciated that various forms of mortice and tenon could be employed though for ease of manufacture and availability of material, the round peg and circular apertures are preferred. Thus, oval, square or rectangular section mortices and tenons or other configurations might be employed in some applications and the section and shaping of the members themselves can be widely varied.

For some forms of framework a fourth horizontal cross member may be required to connect with the pillar assembly shown in Figures 1 to 3. Figure 5 shows an end portion of a fourth cross member 11d which can be connected at right angles to members 11a, 11c to form a continuation of member 11b. This member has an apertured lug 21d to engage tenon 12, and a slot 40 cut out of its upper web to provide

clearance for the wedge 19. A pad 41 is welded to the vertical web of member 11d in the region of slot 40 for reinforcement.

The strength and stiffness of the framework can be added to by use of diagonal bracing to form a triangulated rectilinear structure and Figures 6 to 9 are perspective diagrams of four examples of the many forms of structure which can be provided using the invention.

Figure 6 shows a simple free-standing access platform or tower 49 using four pillar assemblies made up of sets of pillar members 10. The lowest portions of these assemblies are short pillar members 50 provided with adjustable levelling feet 51 shown in detail in Figure 12. Each side frame of the tower includes horizontal members 11 and is braced in the vertical plane by diagonal sloping linking members 52 extending from the tenon at the lower end of a lower pillar member to that at the upper end of the parallel pillar member on that side, members 52 having angled lugs at each end for this purpose. Additional rigidity is provided by horizontal diagonal linking members 53 connecting opposite corners of the frame, and the pillar members in this example are also provided with intermediate attachment points within the web angle to receive further horizontal cross braces 54 or, at the top level, horizontal members 55 forming a safety rail around a deck 56. Toe boards 57 are also shown. A pair of horizontal locking members 58, shown in detail in Figure 10 are used to finish off the tower these having socket formations 59 at each end at right angles to the length of the member with securing U bolts and wedges to engage the uppermost tenon formations of the pillar assemblies.

Figures 7, 8 and 9 are diagrams of three of many and varied forms of framework structures which may readily be assembled using the invention.

Figure 7 shows the bridging of a substantial span between two spaced towers 60, 61 similar to those shown in Figure 6, the righthand tower 61 being extended upwards to a working platform 62, for example at first floor window level. To add to the support of the horizontal span of this structure a further form of member is used, a diagonal cantilever member 63 (see Figure 11). This member has lug 64 angled to be horizontal at its lower end and a tenon formation 65 (as on the pillar members) angled to be vertical at its upper end to receive other members. To add to its rigidity the lower end is also provided with a downwardly extending abutment 66 having a vertical face to locate against a face of the adjoining pillar member.

Also shown is a diagonal outrigger or buttress member 67 (see Figure 13) having angled lugs 68 at each end which extend horizontally in use to connect with respective tenon formations at different levels. Member 67 has an upwardly extending abutment 69 at its upper end with a vertical face to locate against a face of the adjoining pillar member.

In Figure 8 a free standing tower framework 65 is shown with a work platform 66 at second story level cantilivered outward from opposite sides of the main tower using cantilever members 63, stability and support being provided by ground engaging feet 51 mounted on outriggers below the cantilivered parts of platform 66, the outriggers using buttress members 67 secured by locking members 58.

Figure 9 shows another form of framework 70 providing a longer work platform 71 at high level using cantilever members 63, one end of the platform being supported on the roof of a single story building 72.

The different types of member may each be distinctively coloured to facilitate assembly and diagrams of common types of assembly listing the members required to build it may be provided. It is contemplated that such diagrams and listing might be provided for standard or for special purpose structures using a computer which will also be programmed to provide calculations of safe working loading, and, if required, costing of the members needed either on a purchase or hire basis.

Using such a diagram the structures can be safely and reliably assembled even by unskilled or inexperienced labour, e.g. for "do it yourself" repairs or maintenance by householders themselves. As the structure is self-supporting and positively locating from the ground up it can be safely stood on and climbed up as erection proceeds.

The use of members to make up each side of a rectilinear triangulated framework or truss whose loads are transmitted in a common vertical plane along their axes, and the manner in which the loads are all carried to the axially centred tenons without reliance on the integrity of securing or fastening means or application of off-centre loadings thereto as is the case when tubular or other members are secured side by side enables stable free standing structures to be provided avoiding the need in many cases to "tie" them in to a building, and the ability to construct simply and safely cantilevered or bridging structures over a wide span means that

access to many locations otherwise awkward to get to can be readily provided, and that room can be left at ground level for work and for unobstructed and safe passage e.g. along pavements or footways or to the doors or shop windows of a building being worked on.

Different weights or gauges of member may be employed in the same structure, for example a heavier gauge pillar member could be used in the lower parts of a tall tower or scaffolding or for the formation of a hollow girder or cantilever platform to span a substantial distance. Additional members can be purchased and added onto an existing system as required and it is anticipated that there will be considerable cost saving over conventional tubular scaffolding and clamps, for example steel angle equivalent in service to standard scaffold tubing costs, by weight, less than half the price of the latter and is in any event much lighter in weight for a given length. 40mm angle of 3mm gauge steel weighs 1.81Kg per metre length while the same length of standard steel scaffold tube weighs about 3 Kg. and will not withstand the same loading.

Other members and accessories including special purpose fittings can be incorporated in the set of members or adapted to interconnect therewith, for example access ladders or steps, telescopic legs or pillars, ground engaging wheels for moveable towers, staging or stillages, hoists or lifts for materials, doors or shutters for collapsible transport or storage racks or container frames, conveyor tracks etc.

Distal portions of the tenons 12 may each be provided with a through cross-bore to receive a securing bolt or lock e.g. to prevent unauthorised dismantling or tempering with an assembled structure.

CLAIMS

1. A set of members for constructing a dismountable framework comprising a plurality of operatively vertical elongate pillar members (10) and a plurality of elongate linking members (11), end portions of said members being operatively interconnected to form a framework: characterised in that a first end portion of one pillar member has a longitudinally projecting tenon formation (12) and a second end portion of another pillar member has a socket formation (15) opening longitudinally thereof to receive said tenon formation so that said pillar members are operatively aligned in rectilinear end-to-end relationship; and end portions of the linking members each include an apertured lug (21) for engagement with said tenon between said end portions in use to locate the linking member whereby the latter member is located in a vertical plane which includes a common axis of both of said pillar members and said tenon formation.

2. A set of members as in Claim 1 wherein said second end portion is provided with securing means comprising a retaining member displaceable laterally of said end portion to engage the periphery of the inserted tenon formation.

3. A set of members as in Claim 2 wherein the retaining member is a stirrup member (17), and the securing means further includes a wedge or other means (19) for tightening the stirrup member into locking engagement with the tenon formation.

4. A set of members as in Claim 3 wherein the tenon formation has a notch or cutaway (14) with which the stirrup member engages in use.

5. A set of members as in any preceding claim

wherein the first end portion is the operatively upper end of the one pillar member.

5 6. A set of members as in any preceding claim including at least two cross members (11a, b, c) whose apertured lugs (21a, b, c) are engageable with a common tenon formation (12).

10 7. A set of members as in any preceding claim wherein the linking members include at least one cross member which is horizontal in use having apertured lugs at each end for engagement with tenon formations of respective spaced parallel pillar members to provide a rectilinear framework.

15 8. A set of members as in any preceding claim wherein the linking members include at least one diagonal member (52) which is sloping in use having an apertured lug disposed at an angle at the operatively upper end for engagement with the tenon formation at the upper end of one of a pair of parallel spaced pillar members in use and an apertured lug disposed  
20 at an angle at the operatively lower end for engagement with the tenon formation at the lower end of the other of said pair in use to provide a triangulated rectilinear framework.

25 9. A set of members as in any preceding claim wherein the linking members include at least one diagonal member (53) which is horizontal in use for extending diagonally of a rectilinear framework comprising at least four horizontally spaced interconnected pillar members, the latter diagonal member having  
30 an apertured lug at each end to engage respective tenon formations of the pillar members at the opposite corners.

10. A set of members as in any preceding claim including at least one cantilever member (63) having

an angled apertured lug (64) at its operatively lower end and a tenon formation (65) at its operatively upper end angled to be vertical in use on which other members can be located above and horizontally spaced from said lower end.

5

11. A set of members as in any preceding claim including at least one buttress member (67) having apertured lugs (68) at operatively lower and upper ends angled to be horizontal in use whereby the lower end is operatively below and offset horizontally from a member with which the upper end is engaged in use.

10

12. A set of members as in Claim 10 or 11 wherein said cantilever member and said buttress member include an abutment (66,69) providing an operatively vertical face to locate against a face of an adjoining pillar member.

15

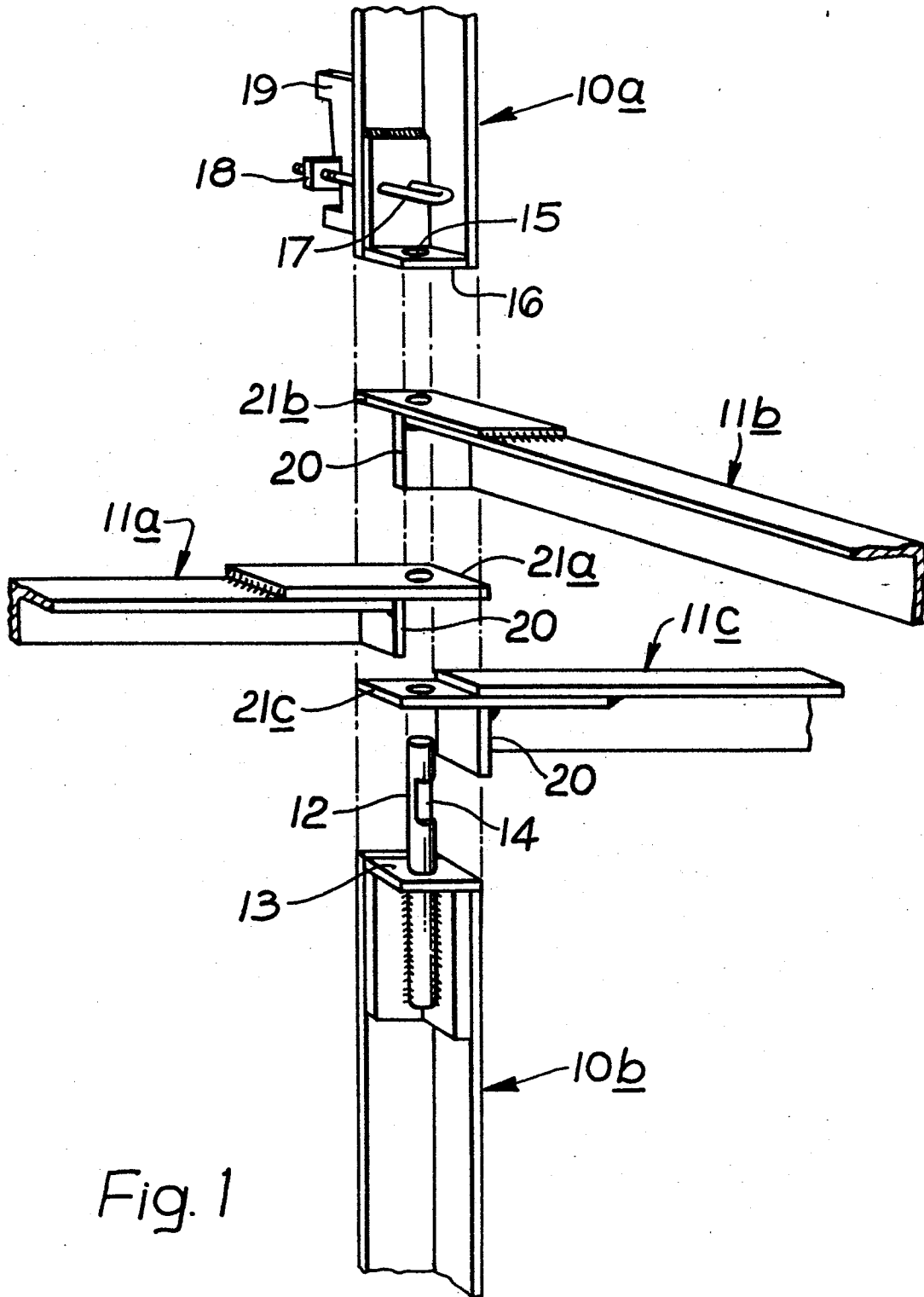
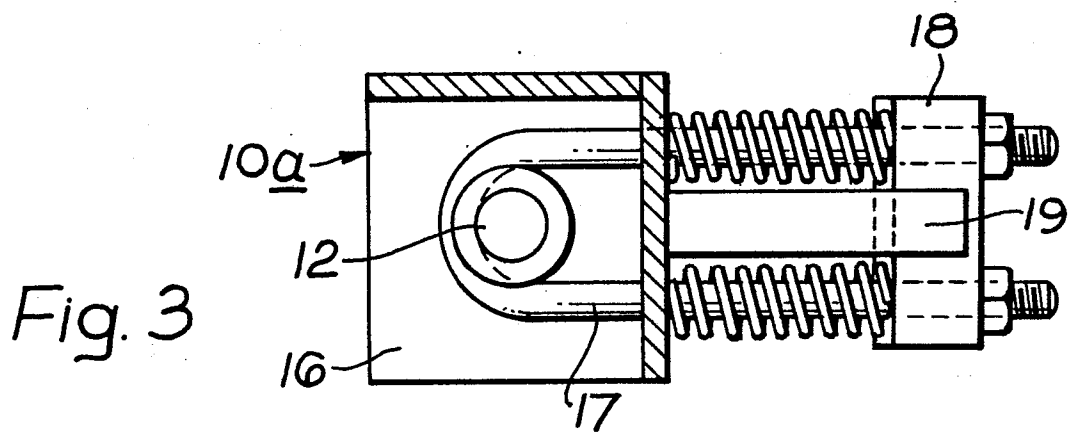
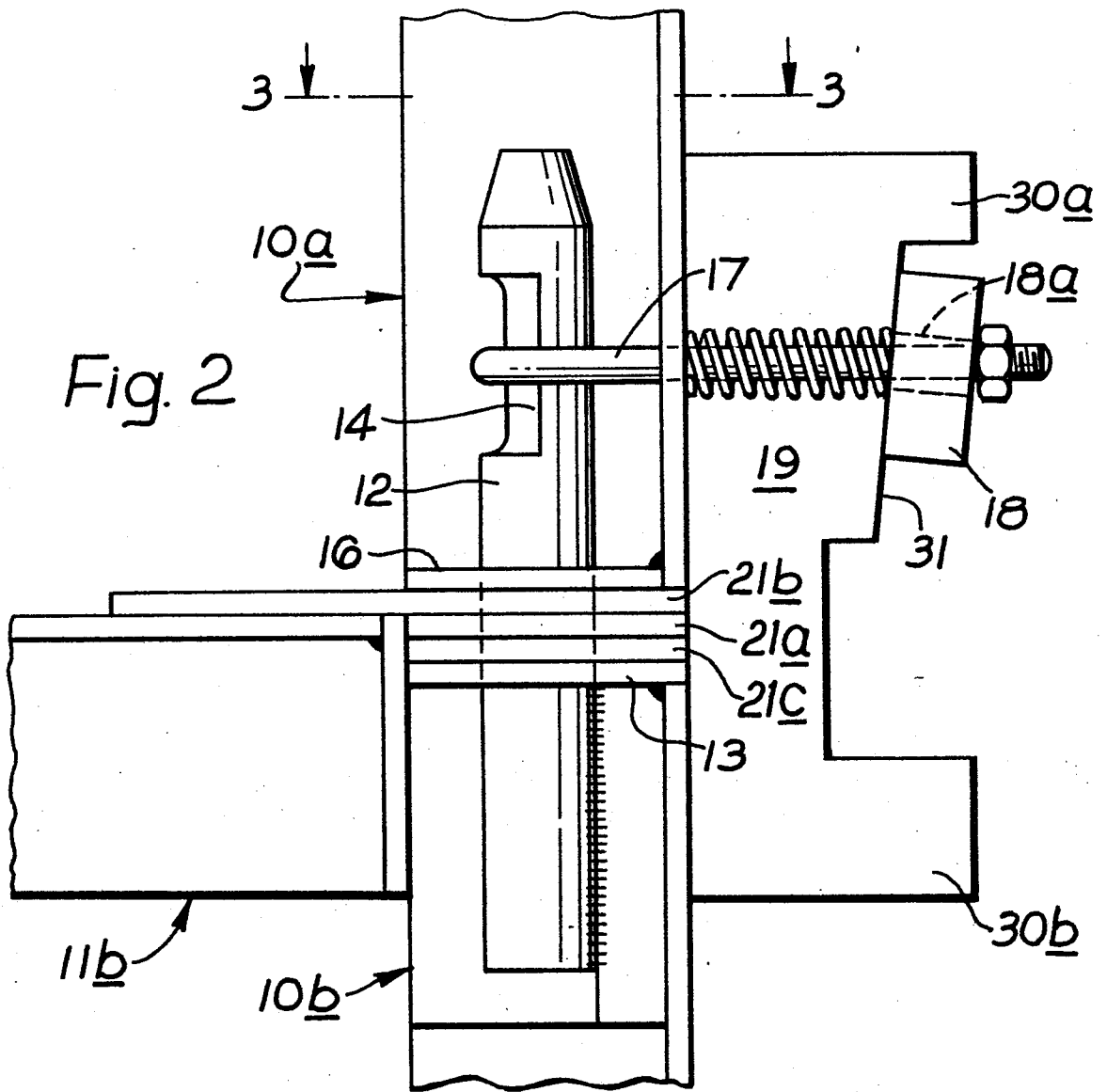

Fig. 1



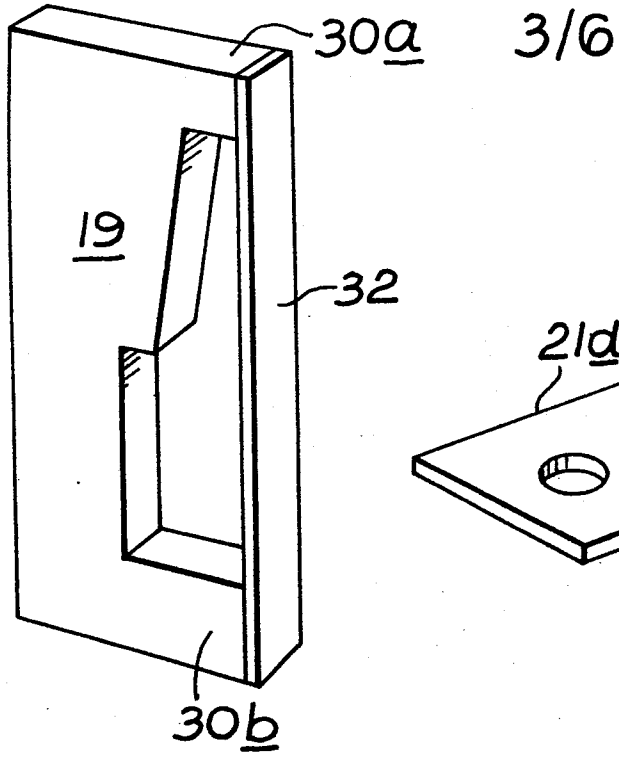

Fig. 4

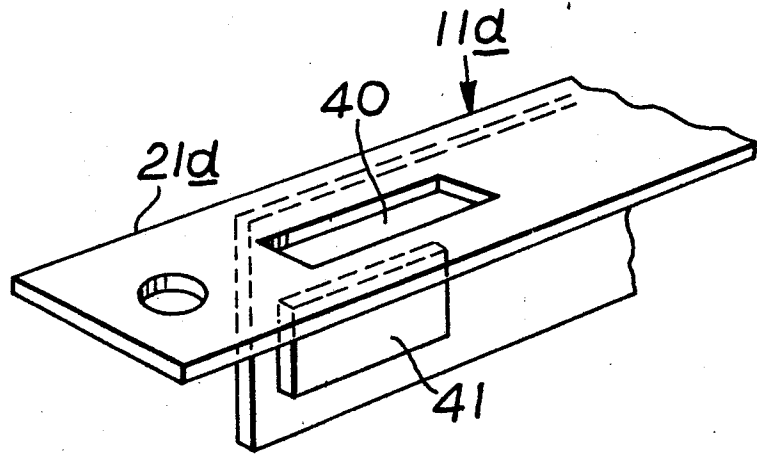

Fig. 5

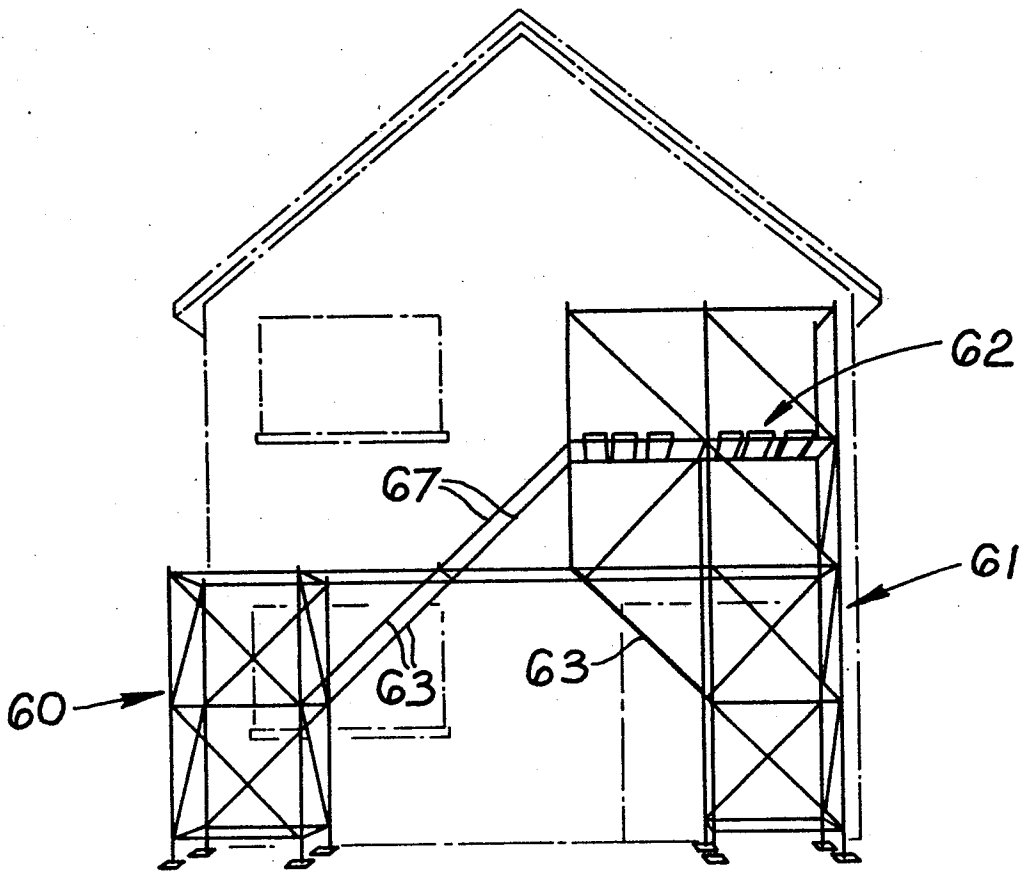

Fig. 7

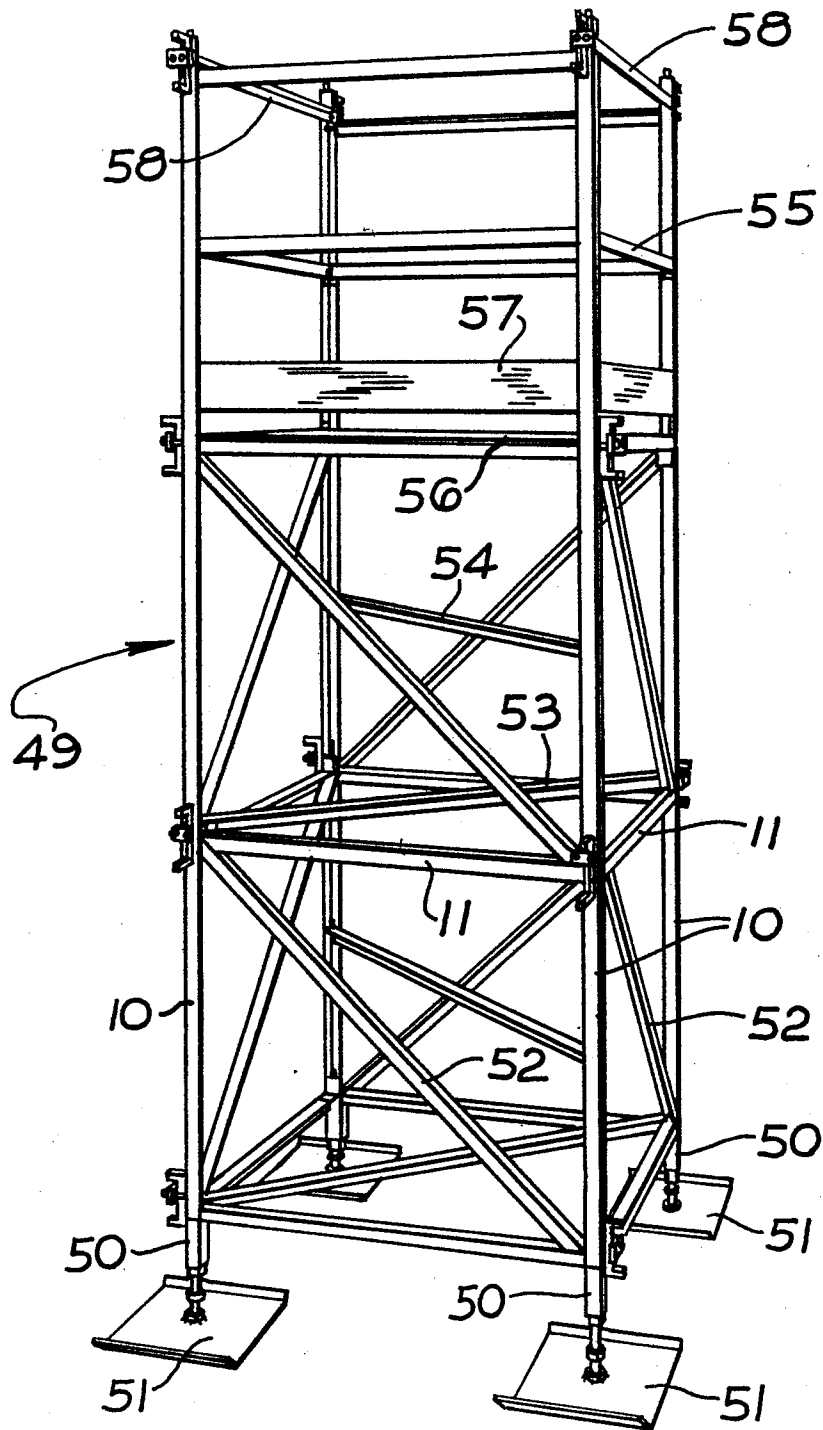
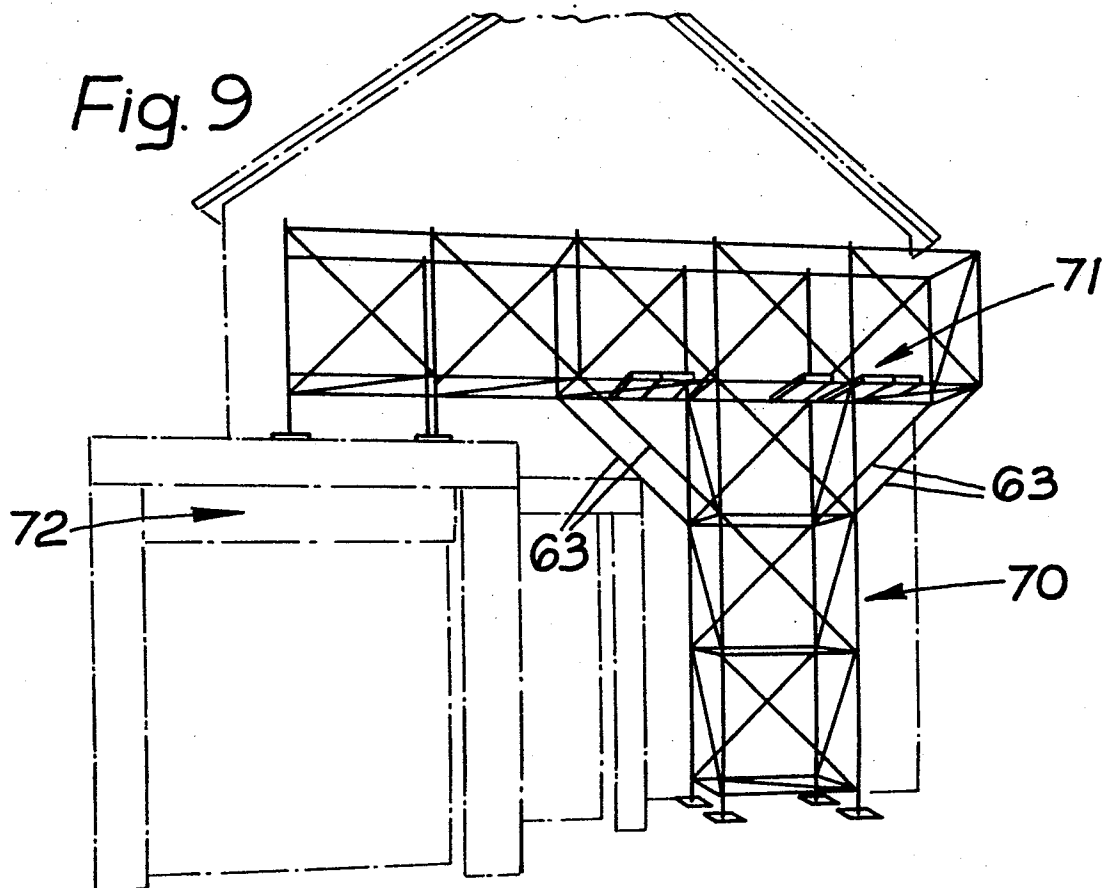
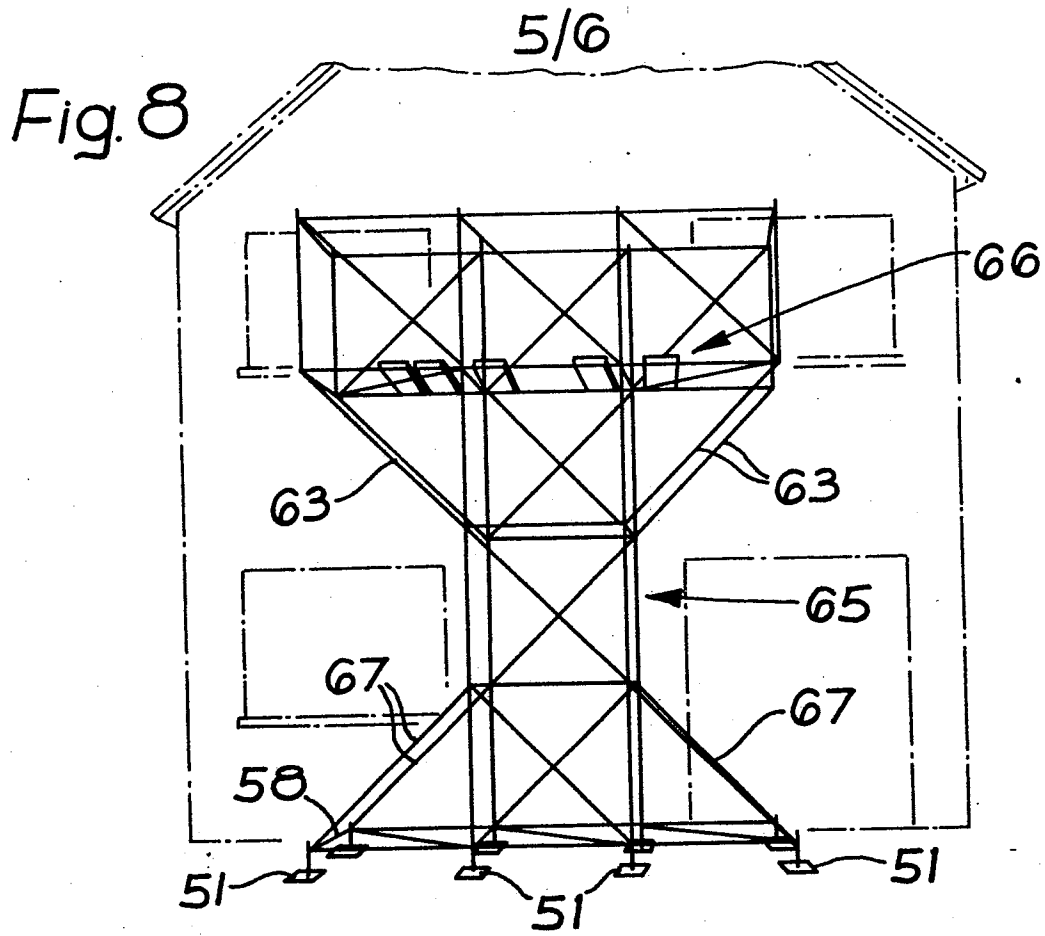

Fig. 6



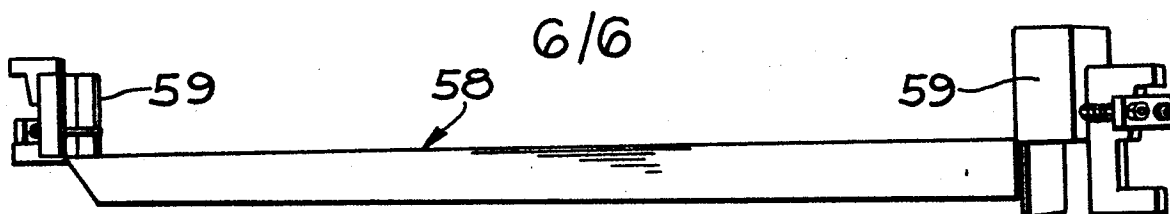

Fig. 10

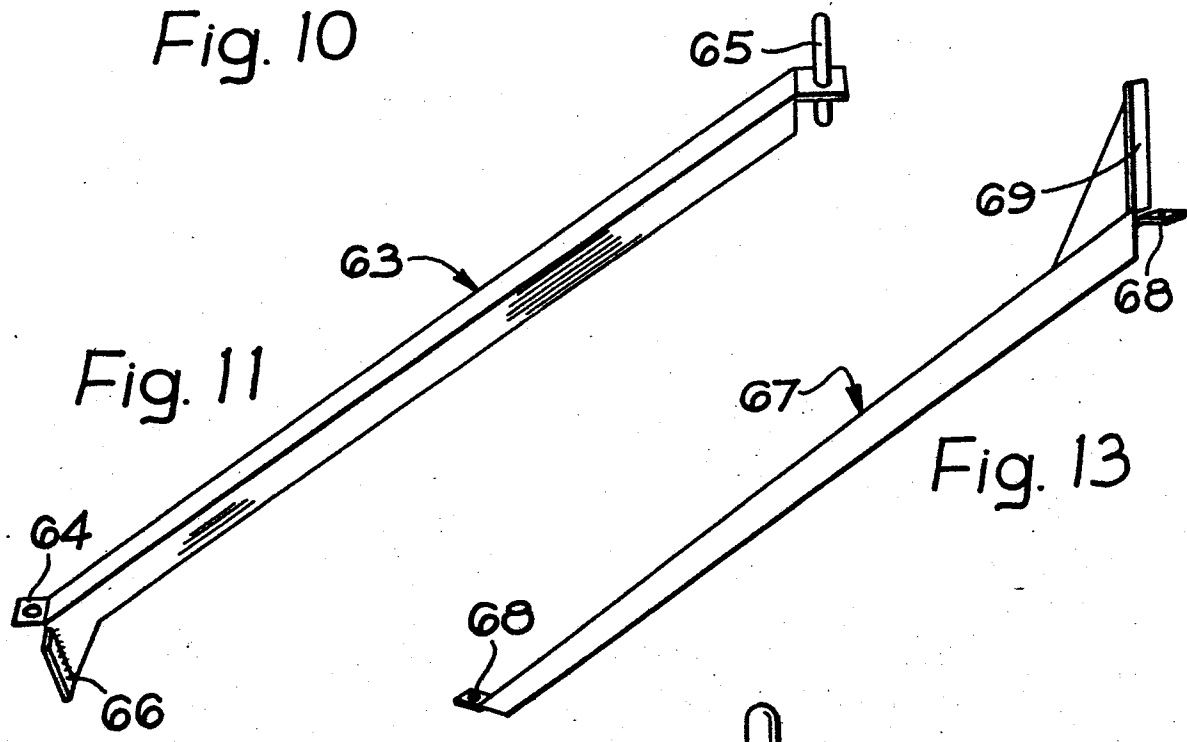

Fig. 11

Fig. 13

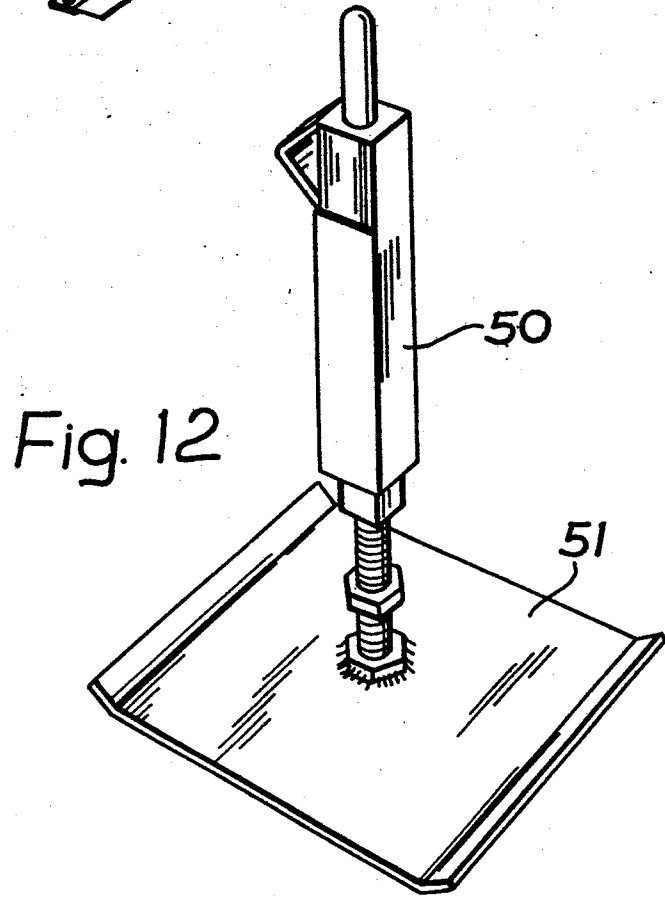

Fig. 12