

No. 814,907.

PATENTED MAR. 13, 1906.

J. L. GLEASON.

JUNCTION BOX FOR ELECTRIC WIRES IN BUILDINGS.

APPLICATION FILED JULY 12, 1905.

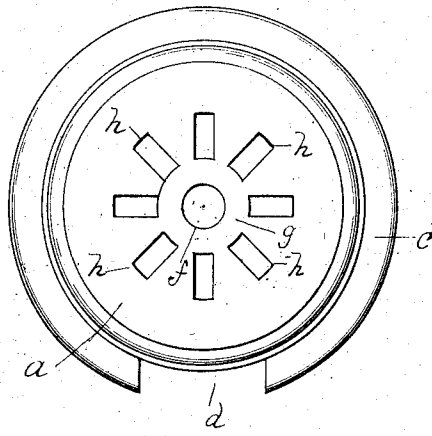

Fig. 1.

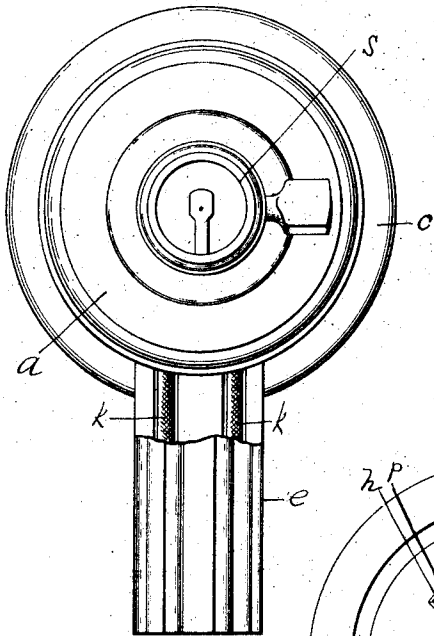

Fig. 2.

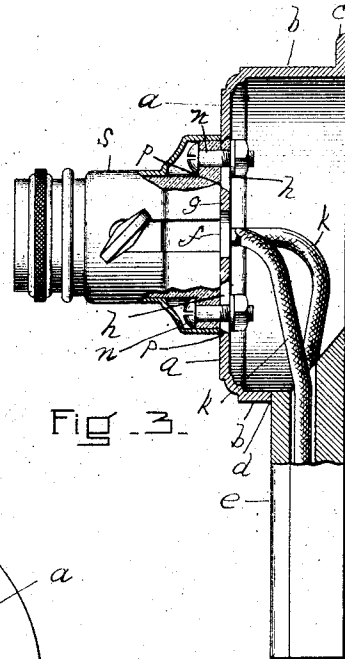

Fig. 3.

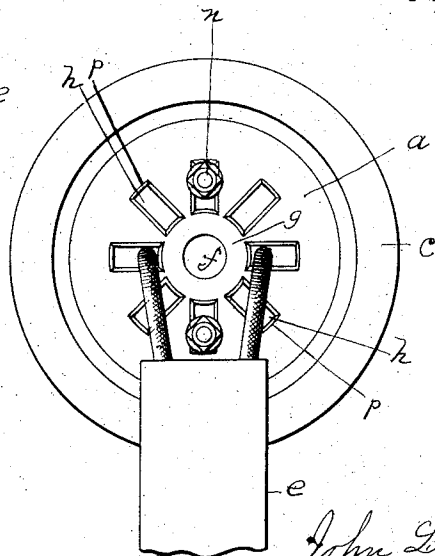

Fig. 4.

WITNESSES

M. A. Atwood,  
John Buckler,

INVENTOR

John L. Gleason,  
By his Atty.,  
Henry Williams

# UNITED STATES PATENT OFFICE.

JOHN L. GLEASON, OF BOSTON, MASSACHUSETTS.

## JUNCTION-BOX FOR ELECTRIC WIRES IN BUILDINGS.

No. 814,907.

Specification of Letters Patent.

Patented March 13, 1906.

Application filed July 12, 1905. Serial No. 269,309.

### To all whom it may concern:

Be it known that I, JOHN L. GLEASON, a citizen of the United States, residing in Boston, in the county of Suffolk and State of Massachusetts, have invented a certain new and useful Improvement in Junction-Boxes for Electric Wires in Buildings, of which the following is a specification.

This invention relates particularly to fire-proof metallic junction-boxes adapted to receive the wires in electric-light systems when said wires are contained in wooden moldings secured to the walls, ceilings, &c., of buildings and apartments therein.

In the present invention the metallic box is circular in shape and is constructed in such a manner that wall-sockets, switches, and other devices connected with electric lighting can be applied to the box, and the electric wires, whether two or four in number, and also the securing-bolts, will in all cases find registering or coincident holes in the wall of the box through which they can extend. In order to accomplish this result, the top wall of the box is provided with a continuous series of radial slots or holes extending entirely around the central portion of said wall and being sufficiently numerous and of sufficient length that whatever style of wall-socket or other device connected with electric lighting is applied to the box covering the holes or slots there will always be some of the said radial slots which will register with the electric wires and the bolts and allow them to extend into the junction-box.

The nature of the invention is fully described below and illustrated in the accompanying drawings, in which—

Figure 1 represents a plan view of my improved junction-box. Fig. 2 is a plan view of the same, showing a wall-socket in position thereon and a wooden molding extending into the box, a portion of said molding being represented as broken out. Fig. 3 is a side elevation of the same, portions being represented as broken out and the junction-box being shown in section. Fig. 4 is a plan view of the under side of the same.

Similar letters of reference indicate corresponding parts.

The box, which is preferably of iron, comprises the flat circular top or wall *a* and a circular side wall *b*, provided at its lower end with the annular flange *c*, and the side wall is furthermore provided with one or more openings *d*, adapted to receive the ends of wooden

moldings *e*, having provision for electric-light wires and adapted to extend along the ceiling or wall of the room.

The flat circular top *a* is provided with a central hole *f* for the accommodation of a bracket-light, and radiating from the solid ring *g*, which surrounds this hole, are numerous slots or holes *h*, each of which is preferably considerably longer than it is wide and extends to a point sufficiently near the outer edge of the top to accommodate the electric wires from any socket, rosette, or switch adapted to be applied to a junction-box or to receive the bolts for securing any such electric-lighting device to the box.

In Figs. 3 and 4 this is illustrated, electric-light wires *k* extending from the molding *e* through two of the radial slots or holes *h* and bolts *n* extending through two others of the radial openings. Thus whether the holes in the wall-socket *s* for the bolts *n* are near together or far apart and whatever may be the position of the holes in the socket for the electric-light wires the socket may be applied in such a position that both the bolt-holes and the wire-holes will register with some portions of some of the radial openings.

In the drawings I have shown eight radial openings, and probably as many as that number would always be advisable in constructing the junction-box. I may, however, make more than eight openings, and said openings should extend entirely around the hole *f* and be equidistant, so as to afford provision for wires or bolts in any portion of the top required for the application of wall-sockets, switches, rosettes, and other devices connected with electric lighting.

In order to prevent rubbing of the wires against the inner corners or edges of the radial openings, said inner edges are beveled from the outer surface of the top *a* outward toward its inner surface, as shown at *p* in Figs. 3 and 4.

Having thus fully described my invention, what I claim, and desire to secure by Letters Patent, is—

1. The herein-described improved junction-box, comprising a side wall, and a substantially flat top provided with a complete circle of radiating slots *h*, for the purpose set forth.

2. The herein-described improved junction-box, comprising a circular side wall, and a substantially flat top provided with a series of radial slots constituting a complete cir-

cle of slots, said circle being concentric with the periphery of the top, for the purpose set forth.

5 3. The herein-described improved junction-box, comprising a circular side wall, and a substantially flat top provided with a series of radial slots constituting a complete circle of slots, said circle being concentric with the periphery of the top, and said slots having

their edges beveled outward toward the under side of the top, for the purpose set forth. 10

In testimony whereof I have signed my name to this specification in the presence of two subscribing witnesses.

JOHN L. GLEASON.

Witnesses:

HENRY W. WILLIAMS,  
M. A. ATWOOD.