

W. J. MOELLER.
 SECTIONAL ASBESTOS COVERING.
 APPLICATION FILED MAR. 7, 1908.

940,265.

Patented Nov. 16, 1909.

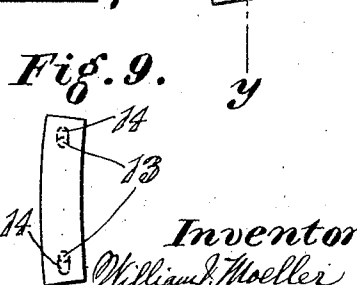
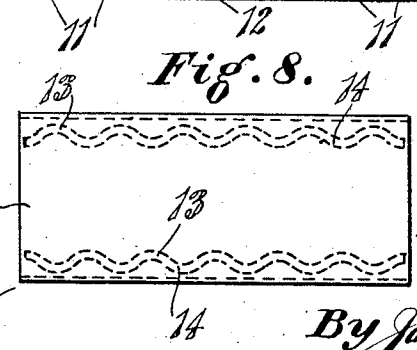
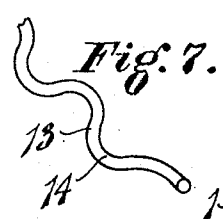
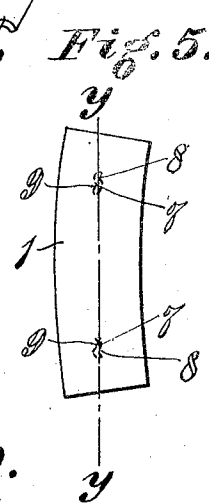
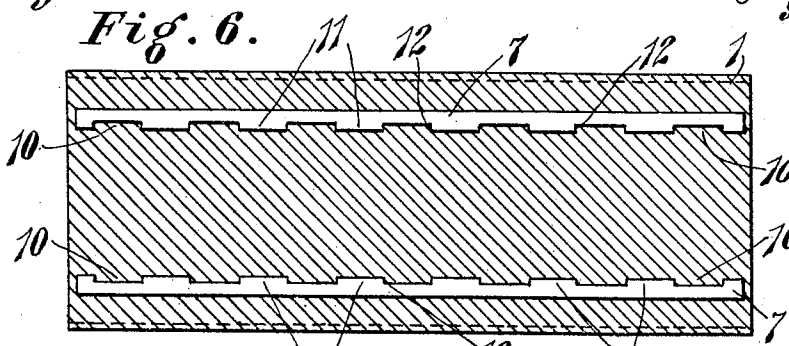
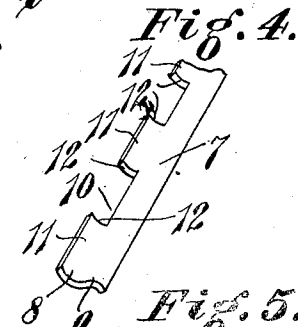
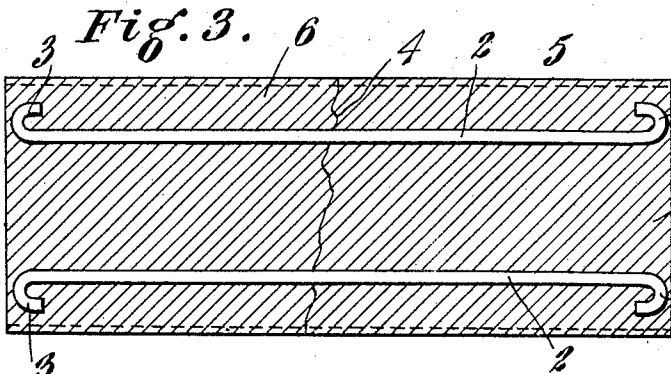
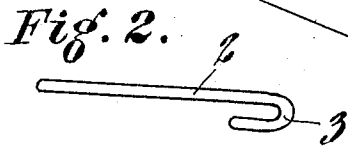
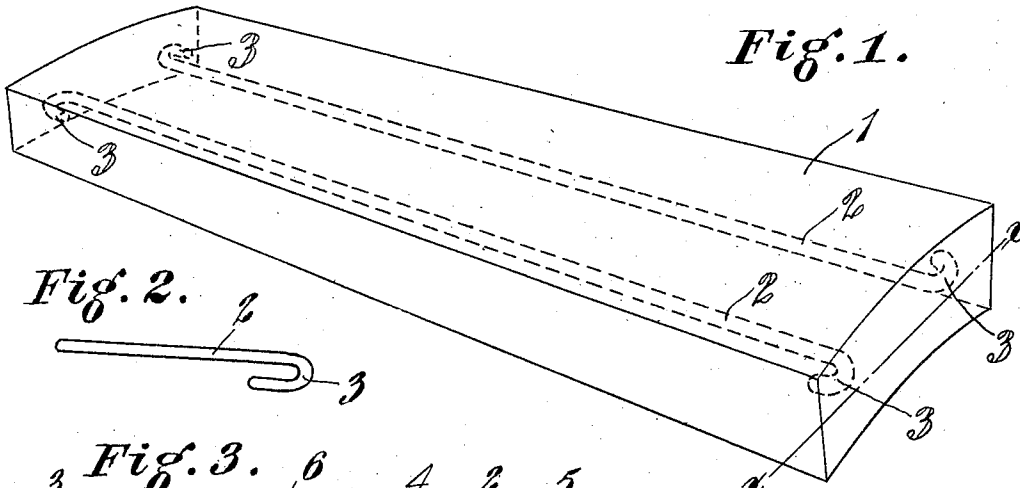

Witnesses:
 Clara Foster
 Stella Rusty

Inventor
 William J. Moeller
 By James A. Rousey
 Attorney

UNITED STATES PATENT OFFICE.

WILLIAM J. MOELLER, OF HARTWELL, OHIO, ASSIGNOR TO THE PHILIP CAREY MANUFACTURING COMPANY, OF LOCKLAND, OHIO, A CORPORATION OF OHIO.

SECTIONAL ASBESTOS COVERING.

940,265.

Specification of Letters Patent. Patented Nov. 16, 1909.

Application filed March 7, 1908. Serial No. 419,640.

To all whom it may concern:

Be it known that I, WILLIAM J. MOELLER, a citizen of the United States, residing at Hartwell, in the county of Hamilton and State of Ohio, have invented certain new and useful Improvements in Sectional Asbestos Coverings, of which the following is a specification.

My invention relates to insulating coverings, the object being to provide such coverings of asbestos in sections of elongated formation reinforced longitudinally against breakage and separation of their parts which may occur in handling. The asbestos in such coverings is usually porous and felted in character.

My invention consists in the combination with such a section of asbestos insulating covering, of a reinforcement bar extending in general direction longitudinally of the section and embedded therein and having projections extending transversely thereof, as will hereinafter be more fully described.

In the drawing: Figure 1 is a perspective view of one of the sections, the reinforcement bars being indicated by dotted lines. Fig. 2 is a detail perspective view illustrating the formation of one of the reinforcement bars illustrated in Fig. 1. Fig. 3 is a cross section on a line corresponding to $x-x$ of Fig. 1, the reinforcement bars being shown in elevation, and the section or block of asbestos covering being represented as broken, but held against separation of its parts by the reinforcement bars. Fig. 4 is a detail perspective view of part of a reinforcement bar of modified formation. Fig. 5 is an end elevation of a section or block of asbestos covering in which reinforcement bars of the formation illustrated in Fig. 4 are used, these reinforcement bars being represented by dotted lines. Fig. 6 is a cross section on a line corresponding to $y-y$ of Fig. 5, the reinforcement bars being shown in elevation. Fig. 7 is a detail perspective view illustrating part of a reinforcement bar of another modified formation. Fig. 8 is a plan view of a section or block of asbestos covering in which reinforcement bars similar to those illustrated in Fig. 7 are used. Fig. 9 is an end elevation of a section of asbestos covering in which reinforcement bars similar to those illustrated in Fig. 7 are used.

As an example of the use of my invention, I have illustrated in the various figures of

the drawing, sections or blocks of asbestos covering of segmental formation such as are usually employed in covering steam pipes or boilers, or other convex surfaces required to be insulated for retaining the heat in them, these sections or blocks being of considerably greater length than of width and thickness. Owing to the fragile nature of the asbestos forming such sections or blocks, and to the necessity of handling the blocks in applying them to the surfaces, it is desirable that they be reinforced against the destructive effects of such handling. This covering being applied, as it is, in sections, and being held upon the surface by additional means, such as sheeting or hoops, or both, a simple fracture such as the one illustrated in Fig. 3 of the drawing will not be of great consequence if the block is held together longitudinally after the fracture, since the sectional nature of the structure of the complete covering primarily involves the presence of joints between the various sections, and an additional joint, which the meeting of the parts of the broken section at the fracture practically constitutes, does not materially reduce the efficiency of the covering. It is for this reason that I provide my improved sectional asbestos covering with reinforcement bars running longitudinally of the elongated sections to reinforce them against transverse fracture, with projections extending substantially transversely of the sections, which will prevent movement of parts of the sections in a direction parallel to the general direction of the reinforcement bars. Thus, in Fig. 1, the elongated segmental asbestos block 1 is provided with internal reinforcement bars 2 running parallel to the greatest length of the block and having hooks 3 formed on their ends, these hooks 3 being disposed laterally of the section or block 1, and consequently at right angles to the general direction of the reinforcement bars 2, which run longitudinally of the block or section 1. The hooks 3, thus extending laterally of the block, form a considerable reinforcement of the block transversely thereof. However, it should be noted that the transverse reinforcement is not so essential, inasmuch as the block is narrow in proportion to its length and thickness and not so subject to fracture longitudinally, as to transverse fracture, such as the fracture 4 illustrated in Fig. 3 of 110

the drawing. It will be readily understood, by referring to Fig. 3 of the drawing that, although the blocks should be fractured as illustrated, the parts 5 and 6 of the block formed by the fracture cannot separate owing to the angular extensions constituted by the hooks 3 on the reinforcement bars 2.

The reinforcement bars 2 are preferably composed of wire, which is embedded in the asbestos when the blocks are made, and are of such thickness that they are sufficiently rigid to form an efficient stay or reinforcement to the block. However, although it is desirable that the reinforcement bars be rigid enough to prevent the transverse fracture of the block, it is also desirable that the weight of the blocks be not increased disproportionately, and to provide for this requirement, a reinforcement bar of the formation illustrated in Fig. 4 may be used, which consists in a strip 7, of sheet metal, curved transversely at 8 and 9, so that it takes the form of a channel and thus constitutes a light and rigid reinforcement of the block longitudinally, when applied as illustrated in Figs. 5 and 6. In order that the reinforcement bars 7 may be angulated and thus be the equivalent of the reinforcement bars 2 illustrated in Figs. 1, 2 and 3 of the drawing, it is provided with recesses or notches 10, so that between these recesses or notches, angular extensions 11 are left which present edges or surfaces 12 disposed transversely of the block and consequently at right angles to the general direction of the reinforcement bars 7, so that they will effectually prevent movement of parts of the asbestos block parallel to the reinforcement bars 7 in case of transverse fracture. In the further modification illustrated in Figs. 7, 8 and 9 of the drawing, the reinforcements are constituted by sinuated wires 13, the sinuations 14 of which constitute projections extending transversely of the block, so that they are equivalent to the projections 3 and 11, of the reinforcement bars 2 and 7, respectively, illustrated in the preceding figures of the drawing.

50 In any of the equivalent formations, illustrated in the drawing and hereinbefore de-

scribed, it will be noted that the reinforcement bars terminate short of the ends of the asbestos blocks so that said reinforcement bars are completely inclosed in the blocks. This complete inclosure of the metallic reinforcement bars is desirable so that the smoothness of the ends of the sections, where joints must be formed in laying the blocks, will be insured.

Asbestos blocks reinforced according to my invention will not only more effectually resist the damaging effects of the handling from the place of manufacture to the place where they are to be used, and in laying them upon the surface to be insulated, but this reinforcement is also useful when it becomes necessary to remove the blocks from the boiler or steam pipe to make repairs. In the case of removal of the asbestos blocks, especially after they have been in use upon the boiler or steam pipe for a considerable length of time, the asbestos composing the blocks has deteriorated. This deterioration, although it increases the insulating quality of the covering rather than decreases it, results in the particles of the asbestos, composing the section or block, becoming incoherent, to the extent that the removal of the sections or blocks for the purpose of repairs to the surface which they have been covering without breaking or destroying them is rendered difficult, unless they are reinforced as herein set forth.

Having fully described my invention, what I claim as new and desire to secure by Letters Patent is:

As a new article of manufacture, a section of asbestos insulating covering comprising porous and felted material formed of one piece in combination with a reinforcement bar extending in general direction longitudinally of said section and embedded therein, said reinforcement bar having projections extending transversely thereof, substantially as set forth and for the purposes specified.

WILLIAM J. MOELLER.

Witnesses:

W. H. SCOBIE;
E. G. ROSS.