

(19)
(12)

(KR)
(A)

(51) 。 Int. Cl. 7
B27B 5/04

(11)
(43)

2002 - 0031973
2002 05 03

(21) 10 - 2000 - 0062780
(22) 2000 10 25

(71)

1

(72)

5

5

5

(74)

:

(54)

(H)

(RUBBER RING MARK)

(SCRATCH)

(12)(14)
(14)
(20)

가 (16)
(40)
가

(10)
(20)
(60)

(30)
(60a)

3

, , , ,

1

2

3

4

5

6

*

*

1.... 10....

12,14.... , 16,42....

20.... 30....

40.... 44....

46.... 가 60....

62.... 64....

66.... 68....

70.... 74....

S.... S,B....

(SIDE TRIMMER)

(H)
(RUBBER RING MARK) (SCRAT

CH)

(SIDE TRIMMER)

1

1

(100)

(110)

(120)(130)

(140)

(150)

(120)(130)

(120)(130)

(150)

(120)(130)

(H)

1

(150)

(150)

(152)

(H) 0.7 - 1.0mm 가

가

(120)(130)

(120)(130)

(120)(130)

(120)(130)

330mm

280mm

0.3 - 0.5mm

가

(150)

(H)

(120)(130)

0.7 - 1.0mm

0.7mm

(150)

(120)(130)

(SCRATCH)가

(H) 1.0mm

(150)

(RUBBER RING MARK)

150)

(152)

(110)

(150)

(H)

(150)

(110)

(152)

(150)

(150)

(150)

(150)

가

(150)

(H)

가 , , (

H) 가 , .

2 , 3 , 5

4 , 6 .

2 3 (1) , (12)(14)

(1) (S) (10) , (30) (30)

가 (16) (20) (60) (60a)

(14) (40) , (60)

(20) 가 .

30 (30) (60) (32) (34)

(36) 가 .

(44)가 (40) , (12)(14) (16)

가 (42) , (42) (16)

(46a) 가 (46b) (45)

(40) (44) , .

(30) (40) (60) □ (60)

(64) (62) (40) (42)

(66a)(66b) (40) (68)

70) (40) 가 (72) (60) (

(60) (60a) (64) (14)

(14) (14) (H) (74)가 .

가 (46) 가 (46b) (10) (16)

(S1)(S2) (44) , .

2 6 (S) (16)

(10) , (10) (16)

(12)(14) .

(12) (20) (14)

(30) (S)

, (30) (14) , (30) (14)
 (H) , 0.7 - 1.0mm , 0.7mm
 (12)(14) 가 가 (30)
 가 가 .
 , (1) (30) (H) (14)
 (H)
 , 3 4 , (10) (14)
 (60) (60b) (74)가 (16)
 (40) (42) (64)
 , (64) (66a)(66b) , (40)
 가 (68) (64)
 , 4 (40) (68) ((70)
 40) 가 (72) (70) , (70)
 (60) (62)
 , 4 (14) (74)
 (30) □ (60) (60b) (74)
 (64) (60) , (14)
 (74)가 (14) 1/2 (60)
 (60) (60a) (30) (14) (H)
 , (30) (14) 0.7 - 1.0mm
 (H) (S)
 , (30) (60) (32) (34)
 (36) , (14) (36)
 , (16) (44) 가 가 (46b) (44)
 (16) 가 (46) 가 (46a) , 가
 (46b) (45) (40) (42)가 .
 , (44) (40) , (40)
 (46b) (14) (16) (14) (S1)(S2) 가
 (B)
 , (44)가 (B) (S2)
 (S2) (44) , (44)가 (B)
 (S2) (44)
 , (30) (14) (H) (14)
 (30)

(57)

1.

(10) , (12)(14) 가 (16)
 (20) (30) ,
 (30) (14) (40) , (60)
 (60a) (20) (H) 가

2.

1 , (40) , (12)(14) (16)
 (44)가 (42) , (42) (
 16) 가 (46)가 (44) (40) ,

3.

1 , (30) (40) (60) □ ,
 (60) (62) (40) (42)
 (64) (66a)(66b) (40) (68)
 (70) (40) 가 (72) (60)

4.

3 , (60) (60a) (64) (14)
 (14) (14) (H) (74)가

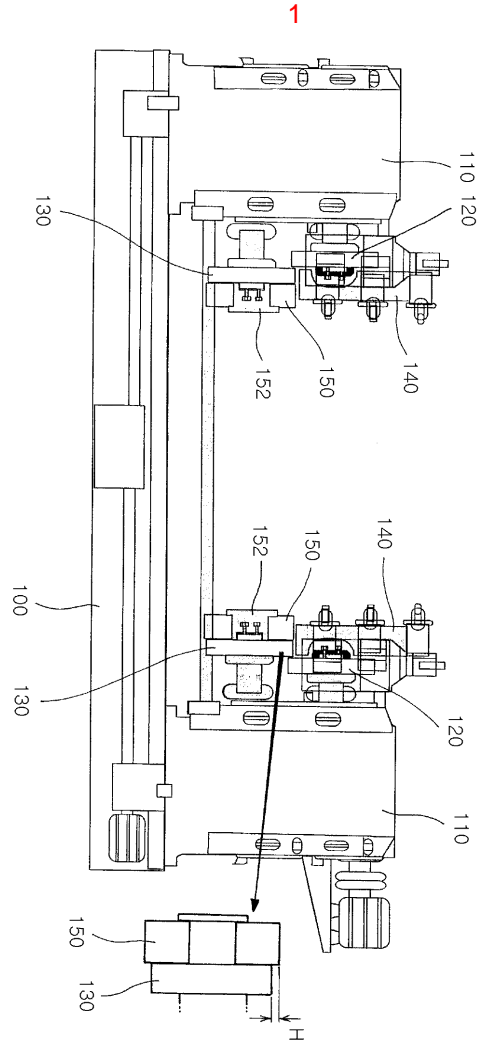

2

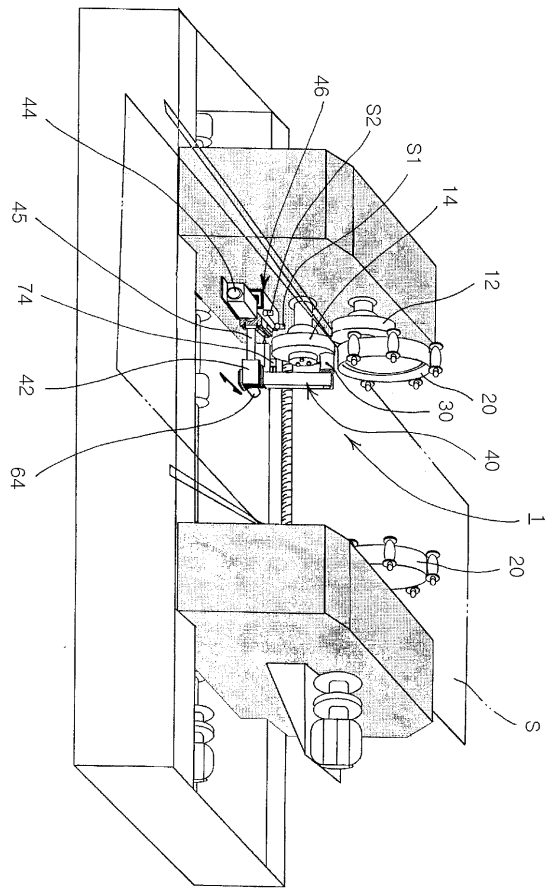

3

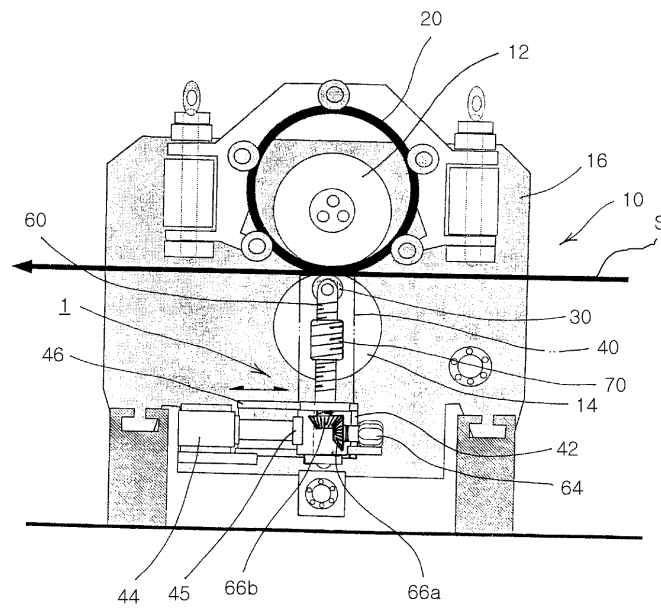

4

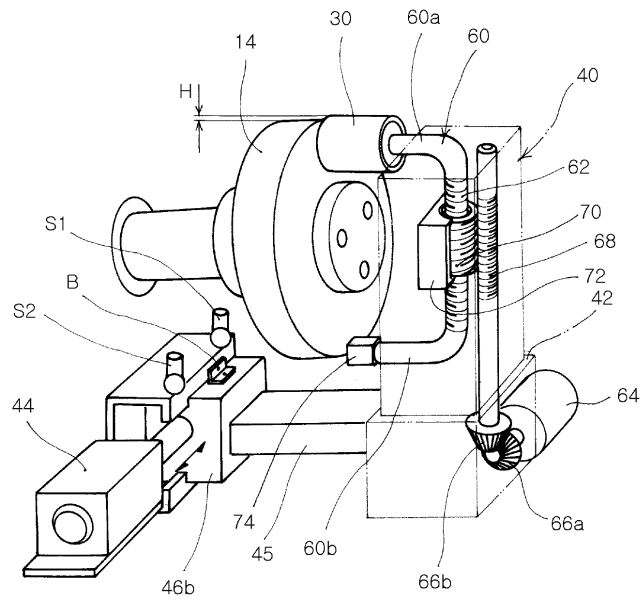

5

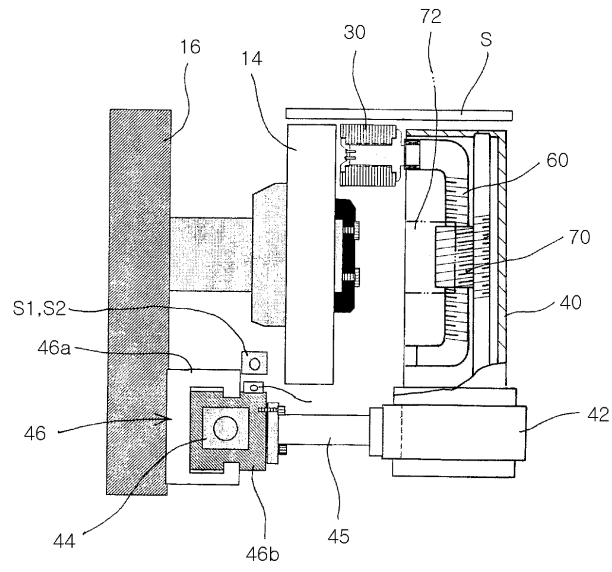

6

