

H. WOOD.
Platform Scales.

No. 107,317.

Patented Sept. 13, 1870.

FIG. 1

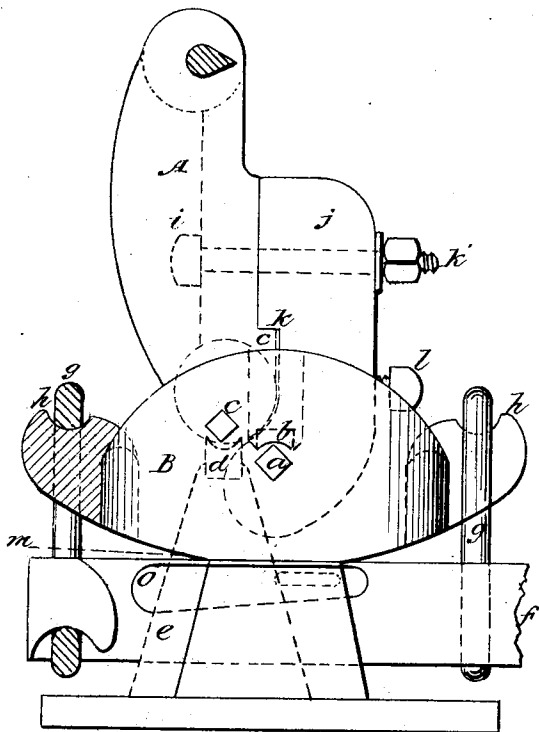

FIG. 2

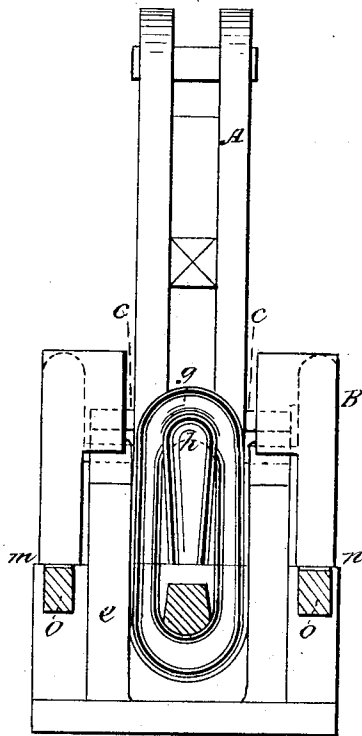
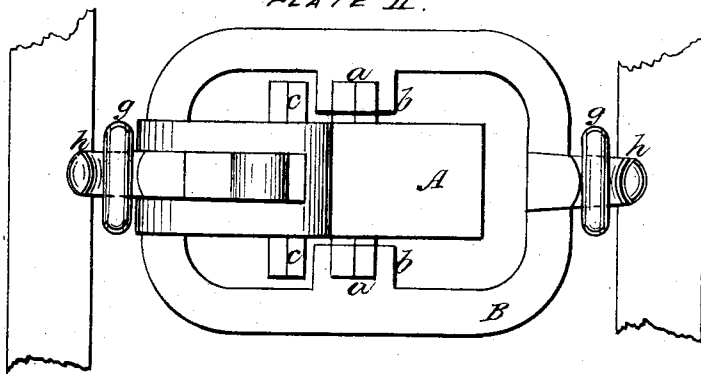

PLATE II.



WITNESSES:

Henry C. Houston
The Franklin Leaver

INVENTOR:

Henry Wood
Per W. H. Clifford, Atty

United States Patent Office.

HENRY WOOD, OF MANCHESTER, ENGLAND.

Letters Patent No. 107,317, dated September 13, 1870.

IMPROVEMENT IN PLATFORM-SCALES.

The Schedule referred to in these Letters Patent and making part of the same.

To all whom it may concern:

Be it known that I, HENRY WOOD, of Manchester, in the county of Lancaster, England, have invented and discovered certain new and useful Improvements in Weighing-Machines; and I hereby declare the following to be a full, clear, and exact description of the same, reference being had to the accompanying drawing forming part of this specification, in which—

Plate 1, Figure 1, shows a side elevation of one set of the levers, with their standard.

Figure 2 is an end elevation of the same.

Plate 2. Herein is shown a top plan of the same devices illustrated in plate 1:

Same letters show like parts.

This invention relates to machines for weighing, and more particularly to those mostly employed in weighing very heavy articles.

The general purposes of the invention are—

First, to provide a means of ready and easy adjustment, by regulation between the bearing or bottom centers, or, in other words, to provide a method of governing and changing the relative lengths of the lifting and tipping-arm or parts of the levers.

Second, to furnish a means of relieving the edges of the bearing parts, when the machine is not in use for weighing, so that these edges may not be impaired in their fineness or sharpness, and thus the certainty and sensitiveness of the machine be preserved for an increased length of time.

As one of the means by which this last-named purpose is accomplished, this invention also exhibits a new and improved construction of standards, upon which the levers are supported, with certain adjuncts to said standards, hereinafter to be described.

This invention consists—

First, in a novel construction and operation of the hoop or horizontal lever B.

Second, in a novel construction and operation of the tipping or vertical lever A.

Third, in a novel means of relieving the knife-edges of those parts upon which the levers are poised or suspended, and upon which they tip or move.

I am aware of the patent of Elnathan Sampson, for a weighing-scale, in which the vertical lever bears some resemblance in form to mine, but the operation and construction are quite different, as will appear from a further description.

I will first particularize the different parts of my invention.

As before said—

A is the vertical, B, the hoop or horizontal lever, which latter lever is suspended from the vertical lever by the lifting center or projection *a*, in combination with the bearing-piece or projection *b*; *a* being on

the vertical lever, and *b* on the inner periphery of the hoop or horizontal lever.

The vertical lever is poised on the edged projections *c*, bearing on the bearing-piece *d*, set in the top of the standard *e*.

The lower platform *f* is suspended from the horizontal levers B by links *g*, fitting snugs *h*, on the upper edges of the said horizontal levers, at the ends thereof, and fitting snugs or recesses on the under side of said platform.

From this it will be seen that, as the vertical lever is inclined, by the movement of the scale-beam or other device, or is tipped on its bearing points or projections *c*, the hoop or horizontal lever is raised, and with it the lower frame or platform, by means of the projections *a* on the vertical lever and the bearing-piece *b* on the said hoop or horizontal lever, and is then held suspended on its (the hoop's) exact center. It may, for clearness, be well to say that there are two internal projections on the hoop B, and two bearing or lifting projections *a* on the vertical lever fitting the same, and the same number of bearing projections, *c*, and resting places, *d*.

Also, that in most scales, four sets of these levers are enough to be employed, (one under each angle of the upper or over platform, or one in each angle of the excavation,) but when, as in railroad scales, great weights are to be sustained, continuous sets can be employed, as in other scales.

The vertical lever A is composed of two parts, *i*, *j*, upper half and pendent half.

They are each made with a shoulder or lip, *k*, one to fit over the other, so that the pendent half *j* rests, by means of its shoulder, on the shoulder *i* of the upper half, in order to relieve the strain of articles being weighed from the bolt or bolts uniting the said two parts, which bolt or bolts might be insufficient to sustain such strain, or at least the exactitude of the machine might be impaired by the partial displacement of the said two parts.

The two bolts are *k* and *l*; *k* the upper or connecting-bolt, *l* the lower or regulating-bolt or screw.

The purpose of the two parts *i* and *j* is to provide a means of adjustment of the scale, by changing the distance between the two projections *a* and *c*, that is, the lifting and bearing centers, by means of the regulating-bolt *l*, or, in other words, to change the relative length of the power and weight-arms of the vertical or lifting-lever.

The distance between the projections *c* and the drag end or center of the vertical lever is unchanging and constant, but the power necessary to lift the platform and ascertain the weight of an article is regulated and ascertained by the distance between *a* and *c*.

Thus a very simple, effective, and reliable means of adjusting the scale is provided.

The standard or support *e* is furnished with shoulders at each side, *m* and *n*. In these are made recesses to receive the wedge-keys *o*.

As before specified, the horizontal hoop or lever *B* passes around or encompasses the standard as well as the vertical lever, but it surrounds the standard only above the shoulders *m* and *n*, which are made to receive the lower edges of said hoop *B* when the machine is not in action. Then, by forcing inwardly the said key equally in all the standards, to secure an equal action, the bearing centers and the lifting centers, also, are simultaneously relieved from the platform, its weight, or any article placed thereon or passing over the same, as vehicles, so that the knife-edges of the projections from the verticle lever are relieved from liability to become worn, or broken, or dulled.

As seen in fig. 1, the bottom of the hoop *B* is curved or rounded, so as to receive or adjust itself to the keys *o*; great advantage is gained by the peculiar form of the hoop *B*, thus giving in each two bearing points on itself, and allowing two projections for them on the vertical lever.

The vertical levers may be connected by rods, as common, with a common drag-buckle on the upper drag-center, for the rods, having an outside jointed connection for the tension-rod, and a right and left-handed connection, by screw, or a swivel and single screw, for the regulation of the lengths of the rods. These are not claimed.

I do not claim the links to support the lower platform, or to suspend it in. These are of common use. The two parts of the vertical lever may be united by having one recessed into the other, if desired; and it is evident that many and various forms of connection

may be made, all of which will allow a sufficient power of regulation between the lower centers.

I do not claim the subjects of the claims of Elnathan Sampson, in his patent of December 23, 1862, and August 28, 1866, hereinbefore referred to.

I do not claim any of the following combinations:

The location under the platform of a scale of a series of bell-crank levers, with yokes and suspension-links, as therein described; the arrangement of a series of bell-crank levers with their long arms in upright position below, and placed transversely to the length of the trackway or the platform. The bell-crank levers, and the combinations therewith, as claimed in either of said patents, are hereby disclaimed.

My invention regulates or sets the scale by variation of distance between the bearing points and those from which the hoop-lever is suspended. I do not specifically claim the form and construction of the vertical lever, but the regulation of the scale, in the manner set forth.

What I claim as my invention, and desire to secure by Letters Patent, is—

1. The vertical or tipping-lever *A*, formed in two parts, secured together as described, for the purpose of allowing an adjustment of position of its bearing points, in combination with the horizontal hoop-lever *B*, and the supporting standard *e*, substantially in the manner herein shown and described.

2. The combination of the vertical and hoop-lever with the standard, having the projections to relieve the knife-edges of the bearing and lifting centers, as herein set forth.

HENRY WOOD.

Witnesses:

JAMES FOLEY,
I. J. C. RODDEN.