

*S. C. Schofield,*

*Tumbling-Shaft Coupling.*

*N<sup>o</sup> 105,259.*

*Patented July 12, 1870.*

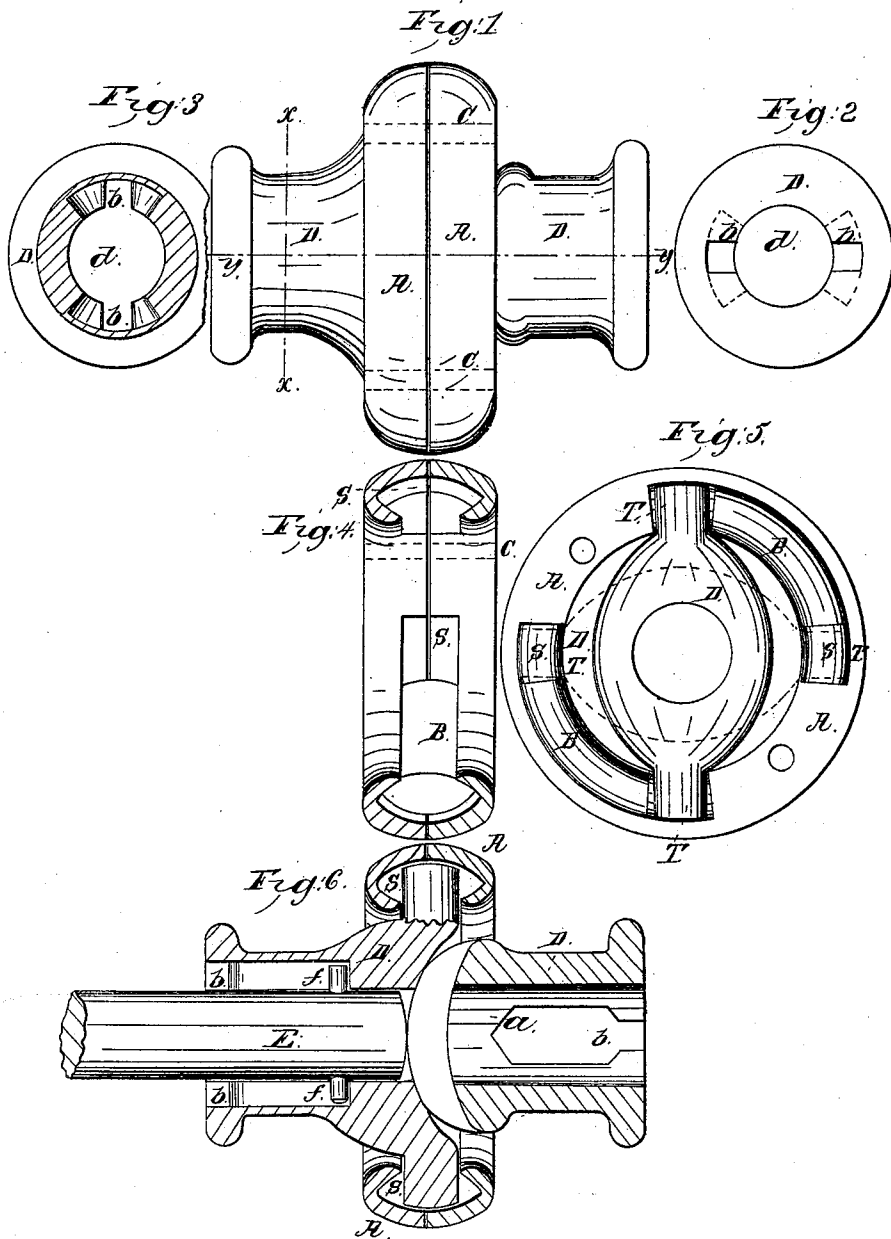

*Witnesses:*  
*L. L. Coffey*  
*Kenneth F. Braub.*

*Inventor:*  
*Silas C. Schofield*

# United States Patent Office.

SILAS C. SCHOFIELD, OF CHICAGO, ILLINOIS.

Letters Patent No. 105,259, dated July 12, 1870.

## IMPROVEMENT IN COUPLING FOR TUMBLING-SHAFTS.

The Schedule referred to in these Letters Patent and making part of the same

I, SILAS C. SCHOFIELD, of Chicago, in the county of Cook and State of Illinois, have invented a new and useful Improvement in Coupling Tumbling-Shafts, of which the following is a specification.

### *Nature and Objects of my Invention.*

The first part of my invention relates to the ring A, made with chambers or grooves for receiving the lugs or trunnions of the coupling-heads and movable blocks, as hereafter described, so that when the ring is fastened together, the trunnions are held within the grooves, and, when in use, will strike against the movable block, which can be removed when worn, and another one substituted at a slight expense.

The second part thereof relates to the blocks sliding in the grooves or chambers, so that the trunnions do not have a rigid bearing, which prevents sudden shocks that are likely to damage machinery, and the blocks can be inserted by simply slipping them in place when the ring A is taken apart.

The third part relates to providing the forks or heads D with recesses or chambers, so as to receive the ends of the tumbling-rod. The pin in the end of the tumbling-rod passes through the slots shown, pass behind the holders of the chamber, and prevent it from uncoupling. The object is the convenience of coupling and uncoupling, as hereafter described.

### *Description of the Drawing.*

Figure 1 represents a side view of my invention.

Figure 2, an end view of one of the heads or forks.

Figure 3, a section of one of the forks or heads taken at the line *z z*.

Figure 4 is a sectional view across the ring with the forks or heads removed.

Figure 5 is a plan view of one of the ring-pieces, showing how the forks or heads are arranged thereon.

Figure 6 is a section, taken at the line *yy* in fig. 1, showing one fork or head with the tumbling-shaft provided with a pin, and the other one with the shaft removed to show the circular extension of the slats in the chamber.

### *General Description.*

A are the coupling-rings, and

C, bolts holding them firmly together.

S are grooves or recesses in the rings A;

B are movable blocks placed in the grooves S;

D are the forks or coupling-heads; and

T, lugs or trunnions thereon.

*a* are the chambers in the coupling-heads D, and *b*, slots for the pin in the shaft to pass into the chamber.

E are the shafts, provided with a pin, *f*.

The coupling-ring A is cast in two parts, which,

when put together, as indicated in the drawing, have two grooves or recesses S.

The movable blocks B are placed in the grooves or recesses S, and are held therein by the projecting edges.

The lugs or trunnions of the coupling-heads D also extend into the recesses S, one of them being at each end of the movable block B, and, when these parts are put together, care should be taken to so arrange them that, when the power is applied to the machine, the trunnions will press against the movable pieces B.

These pieces are made of elastic or soft metal, that will not wear the trunnions of the coupling-heads, but, at the same time, will be durable, and they can be readily replaced if they do become worn.

The bolts C pass through the solid portions of the rings A, and hold them firmly together, thus securing the pieces B and the coupling-heads in place.

The shaft E passes loosely within the chamber *a* in the coupling-head D, the pin *f* passing through the slots *b* into the chamber *a*.

The slots *b* are arranged in the center of the chamber, so that as the shaft turns, the pin strikes the shoulders, and is held within the chamber; but when it is desired to uncouple the tumbling-shaft, the shaft E is so turned within the head D as to bring the pin *f* directly opposite to the slots *b*, whence it can be readily removed.

By so coupling I am enabled, not only to translate power from directions under certain angles to the tumbling-shaft, but, at the same time, there will be the advantage of avoiding a pressure or any strain on the gearing by making the chamber *a* long enough, as to give space, in which the pin *f* may play, if there should be any change in the position of the power applied.

### *Claims.*

Having described my invention,

What I claim is—

1. The ring A, made with chambers or grooves S, for receiving the lugs or trunnions of the coupling-heads D and the movable blocks B, when constructed and operated substantially as and for the purposes specified.

2. The movable blocks B sliding in the grooves or chambers S, when arranged and operating substantially as and for the purposes specified.

3. The coupling-head D, when provided with the chamber *a* and slots *b*, substantially as and for the purposes specified and shown.

SILAS C. SCHOFIELD.

Witnesses:

L. L. COBURN,

HEINRICH F. BRUNS.