

(19) World Intellectual Property Organization
International Bureau



(43) International Publication Date
20 February 2003 (20.02.2003)

PCT

(10) International Publication Number
WO 03/013906 A1

- (51) International Patent Classification⁷: B60P 7/08, B66D 1/16
- (71) Applicant and (72) Inventor: BRUNET, Andre [CA/CA]; 111 Beaudry St., Amos, Québec J9T 3E3 (CA).
- (21) International Application Number: PCT/CA02/01189
- (74) Agent: LESPERANCE & MARTINEAU; 1440 Ste-Catherine St. West, Office 700, Montreal, Québec H3G 1R8 (CA).
- (22) International Filing Date: 29 July 2002 (29.07.2002)
- (25) Filing Language: English
- (81) Designated States (national): AE, AG, AL, AM, AT, AU, AZ, BA, BB, BG, BR, BY, BZ, CA, CH, CN, CO, CR, CU, CZ, DE, DK, DM, DZ, EC, EE, ES, FI, GB, GD, GE, GH, GM, HR, HU, ID, IL, IN, IS, JP, KE, KG, KP, KR, KZ, LC, LK, LR, LS, LT, LU, LV, MA, MD, MG, MK, MN, MW, MX, MZ, NO, NZ, OM, PH, PL, PT, RO, RU, SD, SE, SG, SI, SK, SL, TJ, TM, TN, TR, TT, TZ, UA, UG, US, UZ, VN, YU, ZA, ZM, ZW.
- (26) Publication Language: English
- (30) Priority Data: 2,354,934 9 August 2001 (09.08.2001) CA
- (84) Designated States (regional): ARIPO patent (GH, GM, KE, LS, MW, MZ, SD, SL, SZ, TZ, UG, ZM, ZW), Eurasian patent (AM, AZ, BY, KG, KZ, MD, RU, TJ, TM),
- (63) Related by continuation (CON) or continuation-in-part (CIP) to earlier application: US 09/925,494 (CIP) Filed on 10 August 2001 (10.08.2001)

[Continued on next page]

(54) Title: CLUTCH CONTROLLED LOAD-SECURING STRAP TENSIONING SYSTEM FOR TRAILER

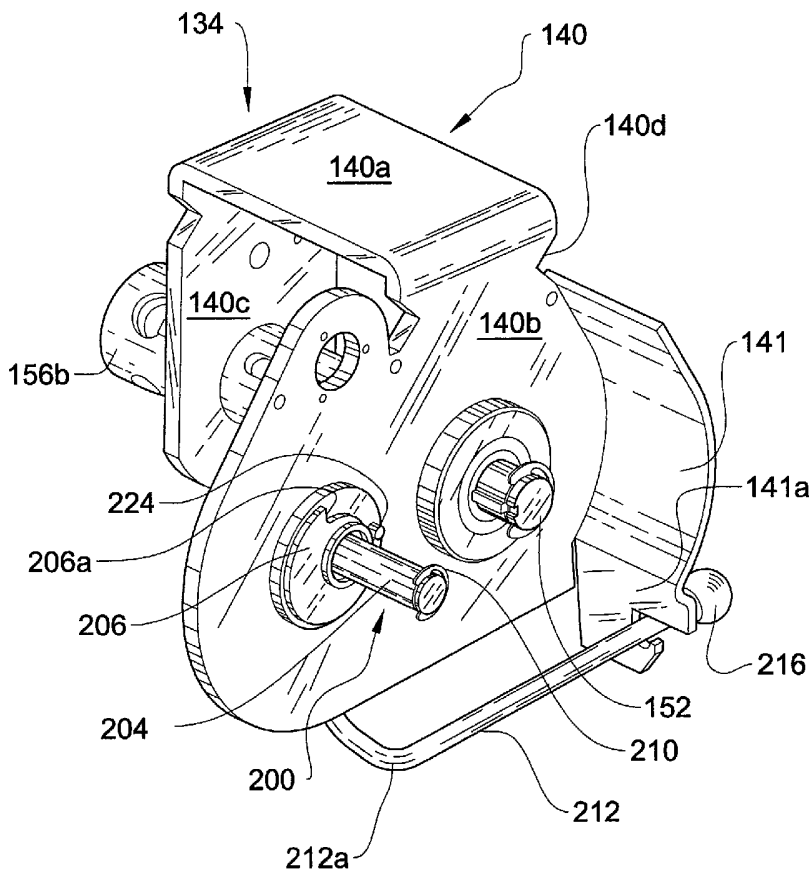

(57) Abstract: A strap winch device assembly (34) for fitting on a flat bed open truck trailer (20), to enable a truck driver to remote actuate this load tightening system without leaving his truck cab, in periodic fashion. A number of these winch devices (34) are connected to a single fore and aft drive shaft (36), which extends along the side of the trailer. The drive shaft (36) is driven by a motor (38) to tighten any straps (5) that loosen when the trailer is in motion over the road, as trailer load distribution typically shifts during road trailer, due to road-induced vibrations. A clutch mechanism (62) is provided in the winch device, to prevent the motor from overheating once a set tightening torque threshold level has been reached. A manual override clutch system (80) is provided, to enable an operator to release the tensioning of the winch device whenever needed.



WO 03/013906 A1



European patent (AT, BE, BG, CH, CY, CZ, DE, DK, EE, ES, FI, FR, GB, GR, IE, IT, LU, MC, NL, PT, SE, SK, TR), OAPI patent (BF, BJ, CF, CG, CI, CM, GA, GN, GQ, GW, ML, MR, NE, SN, TD, TG).

Published:

— *with international search report*

Declaration under Rule 4.17:

— *of inventorship (Rule 4.17(iv)) for US only*

For two-letter codes and other abbreviations, refer to the "Guidance Notes on Codes and Abbreviations" appearing at the beginning of each regular issue of the PCT Gazette.

**TITLE OF THE INVENTION: CLUTCH CONTROLLED LOAD-SECURING
STRAP TENSIONING SYSTEM FOR TRAILER**

CROSS-REFERENCE DATA

5 This application claims Convention priority based upon co-pending Canadian patent application N° 2,354,934 filed August 9th 2001.

FIELD OF THE INVENTION

The invention relates to quick load binding systems for securing and maintaining discrete load elements to a trailer having an open flat bed surface.

10

BACKGROUND OF THE INVENTION

During road shipment of discrete goods on an open flat-bed trailer, for example a plurality of elongated logs of wood from a felled delimbed tree, a strap tightening system is required - and is compulsory under government regulations - to
15 maintain the load in place over the trailer flat-bed, so as to prevent accidental fall of the goods from the trailer under road surface borne vibrations. Loads on open trailers can be conventionally held in place by a number of successive wrap-around straps, extending transversely over the top of the load and spaced from one another in a fore and aft direction. Each of these straps is tightened in place by a corresponding winch.

20

However, due to the surface irregularities bringing a bumpy ride for the trailer pulled by a truck, there is a tendency for these goods to shift during road travel, and therefore, the transverse wrap-around straps become loosened, so that the strap tensioning force applied on the load becomes insufficient. Periodically after each half hour or so, the truck driver must pull his truck to the side of the road and stop his truck, get out and

manually tighten with an elongated one-meter long lever bar once again the flexible strap with a winch. Typically, the applied tensioning load will be about two metric tons for each 10 centimeters wide straps. The lever bar engages through a bore at the free end of the winch shaft.

5 Such a conventional load tightening system is physically demanding for the truck driver, with eventual back pain injuries that can follow after a while. It is inconvenient for the truck driver, when the weather is bad: heavy rain, ice or snow. During road travel, it generates anxiety with the truck driver, as the latter is never sure when exactly the load needs to be re-tightened; also it may take some time before the next
10 upcoming suitable road side space becomes available for temporarily parking the trailer to check the tightening of the load, thus again generating nervousness in the truck driver never knowing if part of his load will accidentally release the flat-bed of his trailer and undesirably fall down onto the road, before he can reach the next upcoming curbside road park space. Moreover, such a load tightening system does constitute a safety hazard for
15 both this truck driver and incoming motorists, because the truck driver has to work on the side of the road, sometimes at night, with an elongated bar projecting away from the truck and partly across the road where incoming motorists may not see the truck driver. Also, such a load tightening system is unreliable since it does not enable the truck driver to uniformly adjust the proper tensioning for each and every strap during road travel. Also,
20 because there may be for example around twelve (12) such transverse straps and strap tensioners on a typical flat bed open trailer, and the truck driver needs to crank each strap winch individually, load tightening is a tiresome and lengthy business.

OBJECTS OF THE INVENTION

25

An object of this invention is to enhance operational safety of flat bed open trailers carrying a plurality of discrete goods.

Another object of this invention is to tighten in a single operation all strap winches of such a flat bed trailer.

Another object of the present invention is to increase efficiency of operation of flat bed open trailers.

Another object of this invention is to reduce the likelihood of work related bodily injuries by truck drivers operating such flat bed trailers.

5 Another object of this invention is to provide an efficient and reliable manual override clutch system, for enabling immediate deactivation of the strap tensioning whenever needed by the operator.

SUMMARY OF THE INVENTION

In accordance with the objects of the invention, there is disclosed a strap
10 winch device assembly for fitting to a truck trailer, to periodically tighten the load supported by the open trailer. This load tightening can be performed either automatically, at set intervals (for example regular intervals), or remotely by the truck driver without having to leave his driving cabin. A number of these winch devices are connected to a
15 single fore and aft drive shaft, which is rotatably carried by and extends along the side of the trailer. The drive shaft is driven by a motor to tighten any straps that loosen when the trailer is in motion over the road. Trailer load distribution typically shifts during road travel, due to road-induced vibrations.

More particularly, the present invention introduces a pneumatic system for automatically - or by remote control - providing tightening load on the wrap-around straps,
20 so that the trucker does not need to periodically stop on the side of the road, and get out of his cab, to manually re-tighten his load with the straps. To the winch cable tightening system, there is added an elongated shaft which extends along the side of the full length of the trailer, and which drivingly engages a pneumatic motor at the front end of the trailer.

This motor is periodically activated during road travel, for short durations each time. This can be done either automatically, at set intervals, or by remote control, at the discretion of the truck driver inside his cab. Upon reaching shipping destination, some of these cable tightening assemblies corresponding to the registering load units to be unloaded, are
5 released manually by a clutch release handle.

This strap tensioning system includes an integral tension limiter, that constantly maintains the tension on the load-tightening straps, contrarily to conventional manual load tightening systems. The automatic tightening system operates thanks to a safety ratchet member, including a locking pawl, to maintain the tightening load without
10 having to continuously maintain in operation the drive motor.

The tightening system mechanism includes three different gear wheels. One gear wheel is located on the drive shaft, the second gear wheel is located on the drum, and the third and last gear wheel interconnects the first and second gear wheels. The third gear wheel is provided with a spring biased system which becomes inoperative when the
15 required tensioning force is reached. This third gear wheel also enables the user to deactivate the drum of the drive shaft with the clutch release arm, to alternately enable a manual operation or the dismantling of the straps.

Also, the strap tensioning devices are slidingly mounted along the elongated motor shaft, so that their relative fore and aft position along the trailer flat bed can be
20 adjusted to fit any type of load. The transmission shaft is for example cross-sectionally hexagonal, but other suitable shapes, most preferably polygonal, or other configurations,

e.g. a knurled surface on an otherwise cylindroid shaft, could be used, provided they allow transmission of power from the motor to the tightening devices.

More particularly, the invention relates to a strap tightening system for use in securing a load with a wrap-around strap over a flat bed open trailer, said system
5 comprising:

- at least one strap tensioning unit, including:
 - a) a main frame, to be mounted to the trailer;
 - b) a strap winding member, rotatably mounted to said main open frame and
10 lockingly engageable by one end portion of the strap;
 - c) a gear assembly, rotatably mounted to said main open frame; - a motor, to be mounted to the trailer at a distance from said tensioning unit and to be connected to a power supply;
- a drive shaft, operatively interconnecting said tensioning unit gear assembly and
15 said motor, said drive shaft bringing said strap winding member to rotate upon actuation of said motor;
- a clutch assembly, operatively interconnecting said gear assembly and said cable winding member, wherein upon the load applied by the tightening strap onto said cable winding member exceeding a set threshold, said clutch assembly disconnects said gear
20 assembly from said cable winding member.

A manual clutch release member may be added, for manually disconnecting said gear assembly from said cable winding member.

A manual strap tightening device could also be added, being associated with said strap winding member, for tightening said strap independently of said drive shaft. A rail member could also be added, said rail member including a first portion, to be anchored to the trailer flat bed in a fore and aft direction, and a second portion, slidingly retaining said strap tensioning unit open frame, wherein the relative position of said strap tensioning unit device can be slidingly adjusted along the length of the trailer in accordance with the relative position on the trailer bed of the load to be secured.

It would also be envisioned to add a safety ratchet and pawl assembly, mounted to said main frame and cooperating with said strap winding member, said safety ratchet and pawl assembly preventing said strap winding member from unwinding once said motor is deactivated.

There may be at least a few strap tensioning units, and preferably between eight and fourteen (8-14), located spacedly from one another and adjustable movable relative to one another along said rail member.

The invention also relates to a method of securing a load on a flat bed trailer with at least one strap tightening unit, the strap tensioning unit of the type having a main frame, to be mounted to the trailer, a strap winding member, rotatably mounted to the main open frame and lockingly engageable by one end portion of the strap, a gear assembly, rotatably mounted to said main open frame, and a clutch assembly, operatively interconnecting said gear assembly and said cable winding member; wherein said method comprises the following steps:

- a) extending the strap transversely over a selected portion of the trailer load carrying bed;
- b) engaging an inner end portion of the strap around said strap winding member;
- 5 c) applying a rotational force on said strap winding member to tighten said strap against the load on the trailer bed;
- d) allowing said clutch assembly to disconnect said gear assembly from said cable winding member, once the load applied by the tightening strap onto said cable winding member exceeds a set threshold;
- 10 e) locking said cable winding member at its threshold load with a lock member;
- f) releasing said rotational force on said strap winding member.

The following additional step (aa) could intervene before said step (a): adjusting the position of said strap tensioning unit along the trailer, to register with the load
15 on the trailer bed. Also, there could be a number of such said strap tensioning units; so that the following additional step would be involved in this method, intervening between said steps (aa) and (a): adjusting the position of the other said strap tensioning units relative to one another, to adapt to the load distribution on the trailer bed.

The invention also relates to a load tightening device for use in securing a
20 load with a wrap-around flexible strap over a flat bed trailer, said device comprising:

- a main rigid frame, to be anchored to the trailer;

- a winding member, rotatably mounted to said main frame and to be connected to the load securing strap for winding the latter;

- power means, for power operating said winding member to wind the strap; -
5 power transmission means, operatively interconnecting said winding member and said power means;

- clutch means, deactivating said power transmission means once the torque applied by the tightening strap onto said strap winding member exceeds a set threshold and said strap winding member reaches a threshold winded state; and

10

- lock means, maintaining said strap winding member in its threshold winded state once said power means is deactivated.

Said gear assembly could include a ring gear, a drive gear integral to said drive shaft and intermeshing with said ring gear; and wherein said clutch assembly
15 includes a clutch casing, mounted radially inward of said ring gear, said clutch casing including a number of radial recesses, a biasing member fully engaged into each of said radial recesses, and a bearing member mounted into each of said radial recesses radially outwardly of said biasing member, said ring gear defining a radially inner edge portion having a number of cavities in register with corresponding said radial recesses, each of said
20 ring gear cavities sized to complementarily accommodate a fraction of a corresponding bearing member, each said bearing member biased by a corresponding one of said biasing

members radially outwardly toward and against a corresponding one of said ring gear cavities, said set load threshold being a function of said biasing member.

There could also be added load adjusting set screws, each of said set screws mounted into a corresponding one of said radial recesses radially inwardly of said biasing member, said set screws enabling an operator to manually adjust said set load threshold.

Said power means could include a drive shaft, to be rotatably carried by the flat bed trailer, and a drive gear, carried by said drive shaft; and wherein said power transmission means includes an idle shaft, mounted to said main rigid frame, and an idle gear, rotatably mounted to said idle shaft coplanar to said drive gear and releasably meshingly engaged with said drive gear and operatively engaged with said clutch means. In that case, a manual override clutch system could be provided, for manually releasing said idle gear from said drive gear. More particularly, said idle shaft could include one and another segment, the latter being axially offset relative to said one segment, said one segment and said another segment providing eccentric motion of said another segment relative to said one segment upon rotation of said idle shaft and accordingly, translational displacement of said idle gear relative to said drive gear, such that a manual override clutch system is obtained by rotating said idle shaft for a fraction of a turn which manually releases said idle gear from said drive gear.

20

DESCRIPTION OF THE DRAWINGS

In the annexed drawings :

Figure 1 is a perspective view of a three-axle trailer, fitted with a load tensioning system according to a preferred embodiment of the invention;

Figure 2 is a cross-sectional view of an intermediate section of the trailer, at an enlarged scale relative to fig 1, showing the load tensioning device according to a first embodiment of the invention being fitted along the lateral edge of the trailer platform bed underface;

Figure 3 is an enlarged perspective view of the first embodiment of load tensioning device, with the gear wheels removed for clarity of the view;

Figure 4 is a view similar to fig 3, but at a smaller scale and further showing two of the gear wheels and the drive gear and a portion of associated drive shaft;

Figure 5 is a view similar to figure 3, but at a smaller scale and from another side of the load tensioning device;

Figure 6 is an exploded view of the gear assembly of the first embodiment of load tensioning device shown in figure 3;

Figure 7 is a plan view of part of one wall from the frame of the load tensioning device shown in figure 3, with the gear assembly removed;

Figure 8 is a cross-sectional view taken along line 8-8 of fig 7;

Figure 9 is an enlarged perspective view of the clutch member forming part of the present load tensioning device;

Figure 10 is a perspective view of the spring discoid support forming part of the clutch member of fig 9, showing in phantom lines the radial cavities for receiving the biasing coil springs;

5 Figure 11 is a perspective view of the tensioning strap engaging arm of the strap tightening device;

Figure 12 is an exploded view of the drive gear assembly of the strap tightening device according to the invention;

10

Figure 13 is a view similar to fig 7 but at a smaller scale and further showing the first embodiment of clutch release assembly with the handle clutch in its released, "power ON" condition;

15 Figure 13a is similar to fig 13, but at a larger scale and with the handle clutch being engaged in its "power OFF" condition;

Figure 14 is an enlarged plan view of the safety ratchet forming part of the strap tightening device;

20

Figure 15 is an enlarged plan view of the ratchet pawl for edgewise engagement with the ratchet of fig 14;

25 Figure 16 is a plan view of the strap tightening device and associated first embodiment of manual clutch release system, suggesting in see-through fashion how the various gear wheels interact with one another;

Figure 17 is a plan view of the clutch release handle from the first embodiment of strap tightening device;

Figure 18 is a schematic view of the trailer mounted drive shaft, showing the drive motor mounted intermediately in between two load strap tensioning units;

5 Figure. 19 is a view similar to figure 3, but showing a second embodiment of load tensioning device including an alternate system for manual clutch override of the tensioning device;

Figure 20 is a view similar to figure 5, but for the second embodiment of load
10 tensioning device;

Figure 21 is a view similar to figure 4, but for the second embodiment of load tensioning device and with the manual clutch release lever arm removed therefrom for clarity of the view;

15

Figure 22 is an exploded view of the eccentric axle assembly forming part of the manual clutch override system from the load tensioning device of figure 19;

Figures 23 and 24 are a plan view and an end view respectively of the eccentric
20 axle assembly of figure 22, but in assembled condition; and

Figure 25 is a perspective view of the manual clutch release lever arm of the load tensioning device of figure 19.

25

DETAILED DESCRIPTION OF THE EMBODIMENTS

In figures 1 and 2 of the drawings, there is shown a flat-bed trailer 20 of the open type, i.e. with no side walls, tail gate or ceiling. Trailer 20 is adapted to be towed by a truck (not shown) at the front end thereof. Trailer 20 includes for example three axles 22,

24, 26, with ground supporting end wheels 28 at the rear end portion of the trailer. A flat bed 30 enables support of a load of discrete commercial articles - for example, a plurality of wood logs from felled delimbed tree - on the top surface thereof, 30a. A reinforced iron angle 32 is mounted on each lateral side edge of the flat bed 30, joining the top surface 30a to the underface 30b of the flat bed 30. A fore and aft extending rail 33 is preferably anchored to the underface of one iron angle 32. Rail 33 includes downturned laterally opposite flanges or lips 33a, 33b. Lips 33a, 33b, are slightly inwardly inturned, as shown.

In accordance with the teachings of the invention, there is provided at least one strap tightening device 34, being mounted slidingly into rail 33. Each strap (fig.11) is destined to be anchored at one end to an anchor point on one lateral side of the trailer flat bed, and to be connected to the strap tightening device 34 at the opposite end thereof. Preferably, there are at least a few such tightening devices 34, 34, 34, ... being positioned in fore and aft register and spaced fashion relative to one another on the same lateral side edge of the trailer. An elongated rotatable shaft 36 extends through and joins all these tightening devices to one another. As shown in fig 18, a motor, preferably an electric motor 38, is mounted at an intermediate section of the trailer in fore and aft register with the shaft 36. Electric motor 38 is connected to a power supply P, for example electrically connected to the alternator of the truck by electrical line, not illustrated, or to a 12 volts battery P. Shaft 36 engages with the motor 38 via an endless chain 39 meshing with a first gear 41 rotatably integral to a motor drive shaft, and with a second gear 43 rotatably integral to shaft 36. The cross-section of shaft 36 should preferably be polygonal, most preferably hexagonal, to enable transmission of power from the motor 38 to the tightening devices 34; but other alternate securing means could also be provided, e.g. knurling of the outer surface of the shaft 36, although this may be less effective or shorter lasting.

According to a first embodiment of the invention, illustrated in figures 3 to 5 and 13-13a of the drawings, there is provided a strap tightening device 34. Device 34 includes a generally U-shape open main frame 40, defining a web leg 40a and two side legs 40b, 40c. Web leg 40a is sized to slidingly fit inside and be retained by cross-sectionally U-shape rail 33 of trailer 20, as suggested in figure 2 of the drawings. The portion of frame

legs 40b, 40c, adjacent web leg 40a, form narrowed necks 40d, 40e, respectively, to slidingly accommodate the inturned lips 33a, 33b, of the trailer rail 33, so as to enable the rail lips 33a, 33b, to support tensioning unit 34 freely over ground. Accordingly, the main frame web leg 40a is preferably sized and shaped for sliding fore and aft engagement with rail element 33. Alternately, leg 40a and rail 33 could be integral to one another, although the sliding adjustment capability is preferred for convenience of the user.

Gear wheels 42, and ring gear 44, are rotatably mounted to the exterior face of main frame leg 40c by axles 36a, 50, respectively, while another gear wheel 46 is rotatably mounted to the same exterior face of main frame leg 40c by a shaft 52. Shaft 50 is an idle rotatable shaft. Another gear wheel 54 is rotatably mounted to the exterior face of main frame leg 40b by a strap tensioning shaft 56. Shaft 56 is coaxial and integral to shaft 52, and diametrically larger relative thereto, and includes a lengthwise slit 56a for locking insertion engagement by one end portion of a load-tightening strap (not shown).

Diametrically smallest drive gear wheel 42 meshes with diametrically larger ring gear 44 in the same plane, whereas diametrically larger gear wheel 46 is offset from the plane of gears 42 and 44. Moreover, another small gear wheel 74 (fig 9) associated with ring gear 44, meshes with gear wheel 46 and is coplanar therewith. Ratchet gear 54 is coaxially mounted to shaft 56 integral thereto.

Rotation of gear wheel 54 opposite gears 42-46, is controlled by a pawl 57 rotatably mounted to main frame leg 40b by a pivotal pin 58. Pawl 57 registers tangentially with and is coplanar to gear 54, and is adapted to engage a selected one of the peripheral recesses 54a (fig 14) formed between a successive pair of teeth 54b, 54c, of gear 54, so that gear 54 and pawl 57 form together a ratchet assembly.

Preferably, the outer end portion 56b of tensioning shaft 56 is enlarged and includes one or two radial through channels 55, for through engagement by a section of an elongated tubular lever bar (not shown), for alternate manual rotation of the tensioning shaft 56 for enabling release of tensioning when unloading is required, or in the event motor 38 become defective or a component of the tightening unit 34 breaks.

The axle 36a of diametrically smallest gear 42 is formed by a segment of the cross-sectionally polygonal drive shaft 36, that brings power from the front motor 38 to the main ring gear 44 via intermeshing gear wheel 42.

As illustrated in fig 6, the gears 42, 46, 74, and ring gear 44 are preferably rotatably sealed inside a closed weatherproof casing 58. The cover 60 of casing 58 includes a bore 60a for free rotatable passage of the cross-sectionally polygonal drive shaft 36.

As shown in figures 9-10 and 16, a clutch assembly 62 is mounted radially inwardly of ring gear 44. Clutch assembly 62 includes a discoid casing 64 having a number of deep cylindroid radial recesses 66. Casing 64 may be for example about 30 cm in diameter and between 15 and 35 cm in thickness. Recesses 66 may be conical at their radially inner end 66a. Casing 64 is sized to fit snugly radially inwardly of ring gear 44. Casing 64 may be constructed as a hollow wheel, with a diametrically smaller rim flanked by opposite rim flanges. A C-shape retaining ring 67 interlocks ring gear 44 and clutch casing 64, by wedging. A coil spring 68 extends fully into each radial recess 66. A free spheroid steel body 70, e.g. of about 13 mm in diameter, is mounted at the radially outward end of the coil springs 68, and a hexagonal socket set screw 71 is mounted at the radially inward end of each radial recess 66. Set screws 71 are complementarily shaped to the radially inner conical end 66a of radial recesses 66. Shallow arcuate recesses 72 are provided on the radially inward face of ring gear 44, in register with corresponding radial recesses 66 of discoid casing 64 when fitted therein. Each hemispheric recess 72 is sized to snugly receive a half section of a corresponding spheroid body 70. The size of the steel balls 70 is a function of the diameter of the ring gear 44. A small gear wheel 74 is anchored by anchor screws 76 flatly against discoid casing 64 coaxially thereto. Gear wheel 74 is coplanar to and meshes with tensioning gear 46. Stationary pivot axle 50 rotatably support both ring gear 44 - via clutch casing 64 - and gear 74.

It can now be understood that as drive shaft 36, powered by main electric motor 38, rotates drive gear 42, intermeshing ring gear 44 is brought in rotation therewith. Under the radially outward biasing force of the coil springs 68, the spherical balls 70

forcibly engage into the corresponding registering radially inward recesses 72 of ring gear 44, thus providing releasable frictional interlock engagement between ring gear 44 and discoid casing 64. As casing 64 is brought into rotation by its interlock engagement with ring gear 44, integral small diameter gear wheel 74 is concurrently brought into rotation. Since gear wheel 74 and tensioning gear 46 intermesh with one another (fig 16), gear 46 is concurrently brought into rotation. Accordingly, the strap end portion locked into shaft slit 56a can become progressively wound around the intermediate body portion of tensioning shaft 56, under power from the main electric motor 38.

However, once the strap or belt has been sufficiently wound around tensioning shaft 56, resistance is felt due to the strap that has become already substantially tightened around the load. At that time, beyond a set torque threshold - adjustable by rotating adjustable set screws 71 inside radial recesses 66 -, the radial springs 68 inside the clutch casing 64 will yieldingly move radially inwardly, thus releasing the frictional interlock between the discoid casing 64 and the ring gear 44. This torque threshold may be within the range of about 1360 to 2270 kilograms, and preferably about 1810 kg.

The clutch 62 has therefore come into action, whereas rotational power transmitted from drive gear 42 to ring gear 44 is no longer able to be transmitted to tensioning shaft gear 46, since intermeshing gear 74 - being integral to now stationary discoid clutch casing 64 - does not rotate anymore.

Therefore, with the present device, once the set tightening load for the load securing strap has been reached, power from the motor 38 will stop being transmitted to the strap tightening shaft 56.

Moreover, the tightened strap will remain taut by the pawl 57 having engaged the ratchet gear 54. A biasing spring 59 (fig 5) carried by frame wall 40c and connected to pawl 57, prevents pawl 57 from accidentally releasing the selected peripheral recess 54a of the ratchet gear 54.

Manual override of the strap tightening force can be achieved by actuating a manual clutch override system, of which a first embodiment 80 is shown in figures 3, 13-13a and 16 of the drawings. Manual clutch override system 80 includes a slider plate 82,

integral to the inner end of gear shaft 50, and a pair of cross-sectionally L-shape guide rail members 84a, 84b, anchored to the outer face of frame wall 40b and slidingly retaining the slider plate 82 therebetween. Rails 84a, 84b, extend parallel to one another, in directions both normal to a virtual line joining shafts 50 and 52, and parallel to a virtual line joining shafts 50 and 36a.

Slider plate 82 is biased into its operative normal position, where ring gear 44 and drive gear 42 intermesh, by a pair of coil springs 86, being integrally supported to main frame leg 40b by a bracket 88.

A metallic cable 90, e.g. of a size about 1.6 mm in diameter, is connected at one end to the end portion of slider plate 82 adjacent the biasing springs 86, and at the other end to a clutch release handle member 92. By manually actuating handle member 92, cable 90 is pulled, thus bringing slider plate 82 into motion against the bias of coil springs 86. The pulling force of cable 90 brings in effect the shaft 50 away from the drive shaft 36a, and therefore the whole ring gear 44 away from the drive gear 42, whereby gears 42 and 44 come to release each other so that no gear intermeshing occur therebetween. This release of the intermeshing between gears 42 and 44 therefore provides release in the strap tensioning at the level of tensioning shaft 56.

More particularly, handle 92 defines a pivotal yoke end 92a, pivotally mounted to main frame 40. Cable 90 extends freely through a main frame flange 40f, extending orthogonal to main frame wall 40b, and joins with an anchor stud 92b of handle 92 proximate pivotal yoke end 92a. Main frame flange 40f forms a seat for the handle free inner end 92c, intermediate pivot mount 92a and cable anchor stud 92b. Accordingly, as handle 92 is brought downwardly outwardly from its generally upright condition shown in figure 13, the handle inner end 92c frictionally engages seat 40f, thus moving studs 92a and 92b away from one another, thus pulling cable 90 therewith. A sliding corner shoulder 94 is preferably mounted to wall 40b proximate bracket 88, for sliding engagement by cable 90, to enable location of handle 92 to be more conveniently laterally positioned to the tightening unit 34 as shown in figure 13, rather than beneath same.

Manual release of the clutch release handle 92 brings once again the gear shaft 50 into operative position, since shaft 50 is able to yield to the bias of the coil springs 86.

A second embodiment of strap tightening device is disclosed as 134 in figures 19 to 25 of the drawings. Strap tightening device 134 discloses an alternate system for manual clutch override. All features in the second embodiment of tightening device, 134, corresponding to those in the first embodiment of tightening device, 34, have been identified in figures 19 to 25 by the same reference numerals, but now being in the 100 series: for example, element 34 becomes element 134.

Again, the strap tightening device 134 includes a generally U-shape open main frame 140, defining a web leg 140a and two lateral side legs 140b, 140c integral to web 140a. A flange 141 transversely projects from wall 140b in a direction opposite wall 140c. Diametrically smaller gear wheel 142, and ring gear 144, are rotatably mounted to the exterior face of main frame leg 140c, opposite flange 141, by axles 136, 200, respectively, while gear wheel 146 is rotatably mounted to the same exterior face of main frame leg 140c by a shaft 152. Gear wheel 154 is rotatably mounted to the exterior face of main frame leg 140b by a strap tensioning shaft 156. Shaft 156 is coaxial and integral to shaft 152, and diametrically larger relative thereto, and includes a lengthwise slit 156a for locking insertion engagement by one end portion of the load-tightening strap (fig 11).

As in the first embodiment of tightening device, coplanar gears 142 and 144 mesh with one another, whereas gear wheel 146 is offset from gears 142 and 144. Offset gear wheel 146 is adapted to mesh with the coplanar small gear wheel (not shown, but corresponding to element 74 in the first embodiment) from the automatic clutch assembly (not shown in figures 19-25, but similar to the one illustrated in figure 9).

Pawl 157, pivotally carried to wall 140c by pivot mount 158, also lockingly yet releasably controls rotation of coplanar diametrically smaller gear wheel 154.

In the second embodiment of tightening device 134, the cable, slider and spring assembly 50, 82, 88, 90 and 92 (see figure 13a) from the first embodiment of tightening device 34, is replaced by an eccentric shaft assembly 200 operatively connected

to an elbowed lever arm member 202. This shaft assembly 200 is shown in figures 22-24, while the lever arm member 202 is illustrated in figure 25.

Shaft assembly 200 includes a rod 204 with an integral ring flange 206 at one end thereof. A stud 208 projects from flange 206 on the opposite side of rod 204. As best shown in figure 23, rod 204 and stud 208 are axially offset relative to one another. Stud 208 includes a cylindroid inner enlargement 208a, adjacent ring 206. Stud enlargement 208a includes an outer notch 208b, opposite ring 206. Ring 206 also includes a sector shape cut-out notch 206a, making about a quarter of the total periphery thereof. Rod 204 is cylindroid. Stud 208 is cross-sectionally polygonal, for example rectangular in cross-section.

Stud 208 extends through and beyond wall 140b, while rod 208 rotatably supports ring gear 144. A clip 210 is engaged into an annular recess 204a at the free end of rod 204, to retain gear wheel 144 in position. As shown in figure 19, sector flange 206 abuts against wall 140b.

Lever arm 202 consists of an elongated rod 212, having an integral axial socket 214 at one end and a handle 216 at the opposite end. Rod 212 includes two spaced elbowed portions 212a, 212b, proximate socket 214. Handle 216 may be for example a spheroid end enlargement of rod 212. Socket 214 includes a polygonal through-bore 218, for example rectangular as illustrated. As suggested in figures 19 and 20, elbowed rod sections 212a, 212b, are sized to conformingly fit around the bottom edge portion of wall 140b; and the through bore 218 of socket 214 is sized for mating through engagement by stud 208 of shaft assembly 200, and complementarily shaped therewith. The lower section 141a of flange 141 includes a laterally outturned notch 141b, for through passage of rod 212 and for retention of handle 216 on the side of flange 141 opposite shafts 150 and 152.

As suggested in figure 22, an inner ring 220 is provided rotatably around stud enlarged section 208a. Ring 220 includes a peripheral cavity 222 receiving therein a fraction of the length of a pin 224. Pin 224 projects beyond cavity 22 and engages through the area circumscribed by sector cavity 206b at the periphery of ring 206. Therefore, rings 206 and 220 - which are on opposite sides of wall 140b - are rotatable relative to one

another, by a fraction of a turn between two limit positions corresponding to the angular value associated with the sector cavity 206a, here for example by a quarter of a turn. Rigid spacer washers 226, 228, are provided on opposite sides of ring 220. Socket 218 is engaged by stud 208, the stud 208 being locked in place by a nut 230 threadingly engaging a threaded end portion of socket 218. Stud 208 is not rotatable relative to socket 218, because of the non circular shape of the through-bore in socket 218 and of the non circular cross-section of the body of stud 208.

In operation, there is provided an alternate system for manual clutch override of the strap tightening device clutch 134. In this alternate system, by manually rotating handle 216, lever arm 212 will transmit this torque to the lever arm end socket 218, which will in turn rotate and bring complementarily shaped shaft socket 208 in rotation therewith. Since shafts 204 and 208 are axially offset relative to one another, translational motion will follow at shaft 204, and therefore at gear wheel 144 carried by shaft 204. As gear wheel 144 is displaced in translation, it will move between a first limit position, in which gear 144 meshes with diametrically smaller gear 142 and therefore enables power transmission to drive idle shaft 204, and a second limit position, in which gear 144 clears smaller gear 142 and therefore prevents transmission of power to idle shaft 204. Hence, we obtain the same result as with the cable, slider and spring assembly 90, 82 and 88 of the first embodiment (figure 3), but with different means and in a fashion which would be very reliable in the long run.

Should there be a power shortage or a mechanical breakdown of the motor, the automatic clutch system 62 (fig 9) can be deactivated and the strap tightening system operated completely manually. The tightening device housing is quite compact, having for example the following dimensions: 20 x 20 x 25 centimeters (cm). The main single motor that drives all the tightening devices of a given trailer, may have for example the following dimensions: 15 x 17.5 x 37.5 cm.. The strap tightening devices and the motor can be mounted onto any type of trailer for the transportation of discrete goods or even for a single load unit placed on the trailer platform bed.

The present load tightening system is particularly well suited - but not limited to pallet-supported commercial articles. Moreover, although the present strap tightening system has been disclosed for use with a flat bed trailer for road trucks, it is envisioned to be within the scope of this invention to apply the strap tightening system to

5 cargo storage platform beds available in trains, water vessels and aircrafts.

10

15

CLAIMS

1. A strap tightening system for use in securing a load with a wrap-around flexible strap over a flat bed open trailer, said system comprising:
- at least one strap tensioning unit, including:
 - 5 a) a main frame, to be mounted to the trailer;
 - b) a strap winding member, rotatably mounted to said main open frame and to be lockingly engageable by one end portion of the strap;
 - c) a gear assembly, rotatably mounted to said main open frame;
 - 10 - a motor, to be mounted to the trailer at a distance from said tensioning unit and to be connected to a power supply;
 - a clutch assembly, operatively interconnecting said gear assembly and said cable winding member; and
 - 15 - a drive shaft, operatively interconnecting said tensioning unit gear assembly and said motor, said drive shaft bringing said strap winding member to rotate upon actuation of said motor and rotation of said gear assembly and said clutch assembly; wherein upon the load applied by the tightening strap onto said strap winding member
 - 20 exceeding a set load threshold, said clutch assembly disconnects said gear assembly from said strap winding member, whereby transmission of power from said drive shaft to said strap winding member is interrupted.
2. A strap tightening system as in claim 1,
- 25 further including a releasable safety ratchet and pawl assembly, mounted to said main frame and cooperating with said strap winding member, said safety ratchet and pawl assembly preventing said strap winding member from unwinding once said set load threshold has been exceeded.

3. A strap tightening system as in claim 2,
further including a rail member, said rail member including a first portion, to be anchored
to the trailer flat bed in a fore and aft direction, and a second portion, slidably retaining
said strap tensioning unit open frame, wherein the relative position of said strap tensioning
unit device can be slidably adjusted along the length of the trailer in accordance with the
5 relative position on the trailer bed of the load to be secured.

4. A strap tightening system as in claim 3,
wherein there are at least a few strap tensioning units, located spacedly from one another
and adjustably movable relative to one another along said rail member.
10

5. A strap tightening system as in claim 2,
further including a manual clutch release member, for manually disconnecting said gear
assembly from said strap winding member.
15

6. A strap tightening system as in claim 2,
further including a manual strap tightening device, associated with said strap winding
member, for tightening the strap independently of said drive shaft.

7. In combination, an open trailer having a flat bed, and a strap tightening
system securing a load with a wrap-around flexible strap over said flat bed, said system
comprising:
20

- at least one strap tensioning unit, including:
25
 - a) a main frame, mounted to the trailer;
 - b) a strap winding member, rotatably mounted to said main open
frame and lockingly engageable by one end portion of the strap;
 - c) a gear assembly, rotatably mounted to said main open frame;

- a motor, anchored to the trailer at a distance from said tensioning unit and to be connected to a power supply;
- 5 - a clutch assembly, operatively interconnecting said gear assembly and said cable winding member; and
- a drive shaft, operatively interconnecting said tensioning unit gear assembly and said motor, said drive shaft bringing said strap winding member to rotate upon actuation of said motor and rotation of said gear assembly and said clutch assembly; wherein upon the load applied by the
10 tightening strap onto said strap winding member exceeding a set load threshold, said clutch assembly disconnects said gear assembly from said strap winding member, whereby transmission of power from said drive shaft to said strap winding member is interrupted.

15

8. A method of securing a load on a flat bed trailer with at least one strap tightening unit, the strap tensioning unit of the type having a main frame, to be mounted to the trailer, a strap winding member, rotatably mounted to the main open frame and lockingly engageable by one end portion of the strap, a gear assembly, rotatably mounted
20 to said main open frame, and a clutch assembly, operatively interconnecting said gear assembly and said strap winding member; wherein said method comprises the following steps:

- 25 a) extending the strap transversely over a selected portion of the trailer load carrying bed;
- b) fixedly engaging an inner end portion of the strap around said strap winding member;
- c) applying a rotational force on said strap winding member to tighten said strap against the load on the trailer bed;

- 5 a
- d) allowing said clutch assembly to disconnect said gear assembly from said strap winding member, once the load applied by the tightening strap onto said strap winding member exceeds a set load threshold;
 - e) locking said strap winding member at its said set threshold load with lock member; and
 - f) releasing said rotational force on said strap winding member.

9. A method of securing a load on a flat bed trailer as in claim 8, further including the following step (aa), intervening before said step (a):
10 adjusting the position of said strap tensioning unit lengthwisely along the trailer, to register said position with the load on the trailer bed.

10. A method of securing a load on a flat bed trailer as in claim 9, wherein there are a number of said strap tensioning units; and further including the
15 following step, intervening between said steps (aa) and (a):
adjusting the positions of the other said strap tensioning units relative to one another, to adapt to the load distribution on the trailer bed.

11. A load tightening device for use in securing a load with a wrap-around
20 flexible strap over a flat bed trailer, said device comprising:

- a main rigid frame, to be anchored to the trailer;
- a strap winding member, rotatably mounted to said main rigid frame and to
25 be connected to the strap for winding the latter;
- power means, for power operating said winding member to wind the strap;
- power transmission means, operatively interconnecting said winding member and said power means;

- automatic clutch means, automatically deactivating said power transmission means once the torque applied by the strap onto said strap winding member exceeds a set load threshold and said strap winding member reaches a threshold cranked state; and

5

- lock means, maintaining said strap winding member in its said threshold cranked state once said power means is deactivated.

12. A strap tightening system as in claim 2,
10 further including an adjustment member, mounted into said clutch assembly for adjustably varying the magnitude of said set load threshold.

13. A strap tightening system as in claim 2,
wherein said gear assembly includes a ring gear, a drive gear integral to said drive shaft
15 and intermeshing with said ring gear; and wherein said clutch assembly includes a clutch casing, mounted radially inward of said ring gear, said clutch casing including a number of radial recesses, a biasing member fully engaged into each of said radial recesses, and a bearing member mounted into each of said radial recesses radially outwardly of said biasing member, said ring gear defining a radially inner edge
20 portion having a number of cavities in register with corresponding said radial recesses, each of said ring gear cavities sized to complementarily accommodate a fraction of a corresponding bearing member, each said bearing member biased by a corresponding one of said biasing members radially outwardly toward and against a corresponding one of said ring gear cavities, said set load threshold being a function of said biasing
25 member.

14. A strap tightening system as in claim 13,

further including load adjusting set screws, each of said set screws mounted into a corresponding one of said radial recesses radially inwardly of said biasing member, said set screws enabling an operator to manually adjustably vary said set load threshold.

5 15. A strap tightening system as in claim 11,
wherein said power transmission means includes a ring gear, a drive gear integral to said
power means and intermeshing with said ring gear; and wherein said clutch means includes
a clutch casing, mounted radially inward of said ring gear, said clutch casing including a
number of radial recesses, a biasing member fully engaged into each of said radial recesses,
10 and a bearing member mounted into each of said radial recesses radially outwardly of said
biasing member, said ring gear defining a radially inner edge portion having a number of
cavities in register with corresponding said radial recesses, each of said ring gear cavities
sized to complementarily accommodate a fraction of a corresponding bearing member,
each said bearing member biased by a corresponding one of said biasing members radially
15 outwardly toward and against a corresponding one of said ring gear cavities, said set load
threshold being a function of said biasing member.

 16. A strap tightening system as in claim 15,
further including a load adjusting set screw, each mounted into a corresponding one of
20 said radial recesses radially inwardly of said biasing member, said set screw enabling
an operator to adjustably vary said set load threshold.

 17. load tightening system as in claim 11,
wherein said power means includes a drive shaft, to be rotatably carried by the flat bed
25 trailer, and a drive gear, carried by said drive shaft; and wherein said power transmission
means includes an idle shaft, mounted to said main rigid frame, and an idle gear, rotatably
mounted to said idle shaft coplanar to said drive gear and releasably meshingly engaged
with said drive gear and operatively engaged with said clutch means.

18. A load tightening device as in claim 17,
further including a manual override clutch system, separate from said automatic clutch
means, said manual override clutch means for manually releasing said idle gear from said
drive gear.

5

19. A load tightening device as in claim 17,
wherein said idle shaft includes one segment and another segment axially offset relative to
said one segment, said one segment and said another segment providing eccentric motion
of said another segment relative to said one segment, upon rotation of said idle shaft, and
10 accordingly, translational displacement of said idle gear relative to said drive gear, such
that a manual override clutch system is obtained by rotating said idle shaft for a fraction of
a turn which manually releases said idle gear from said drive gear.

15

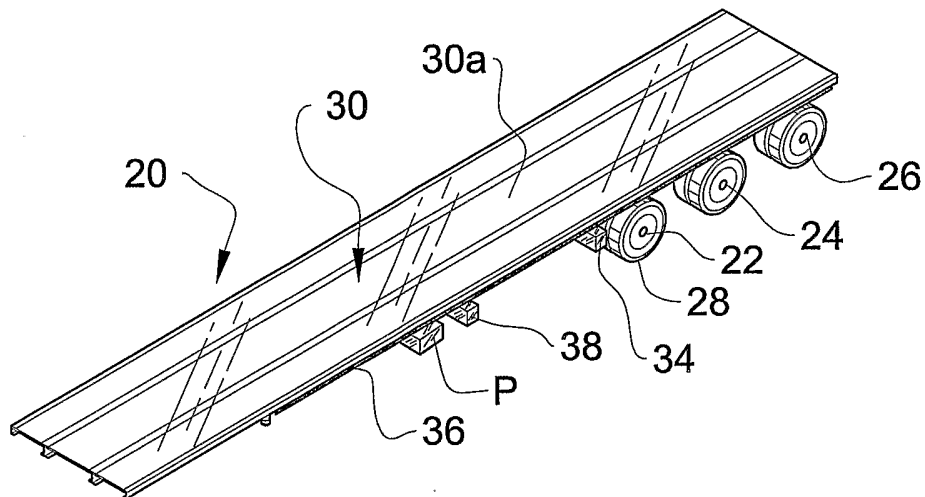

Fig.1

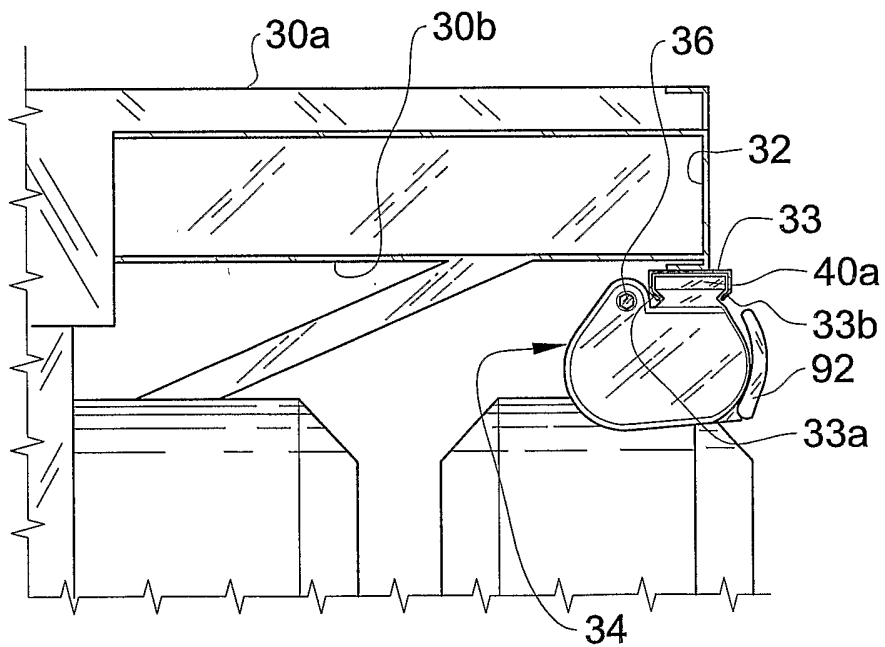

Fig.2

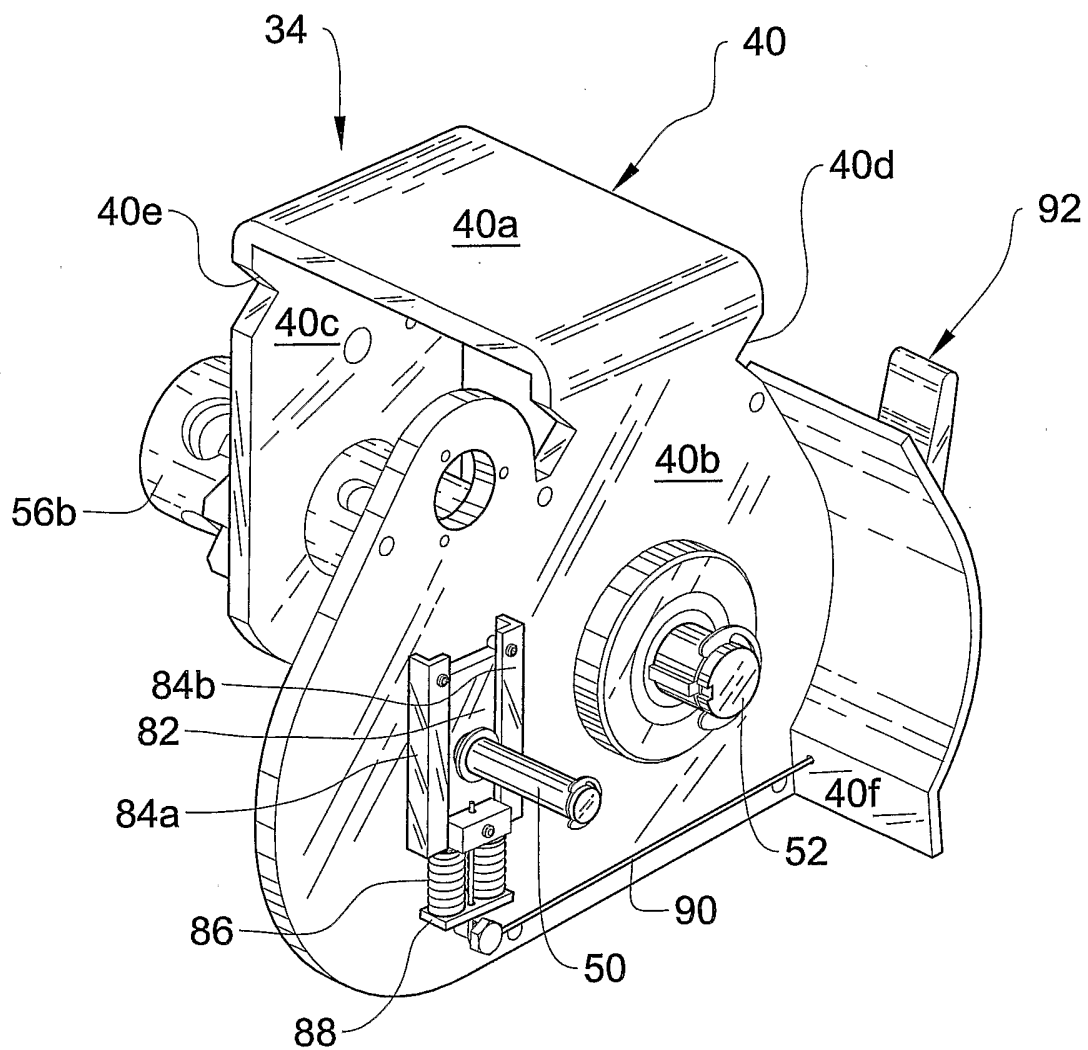

Fig. 3

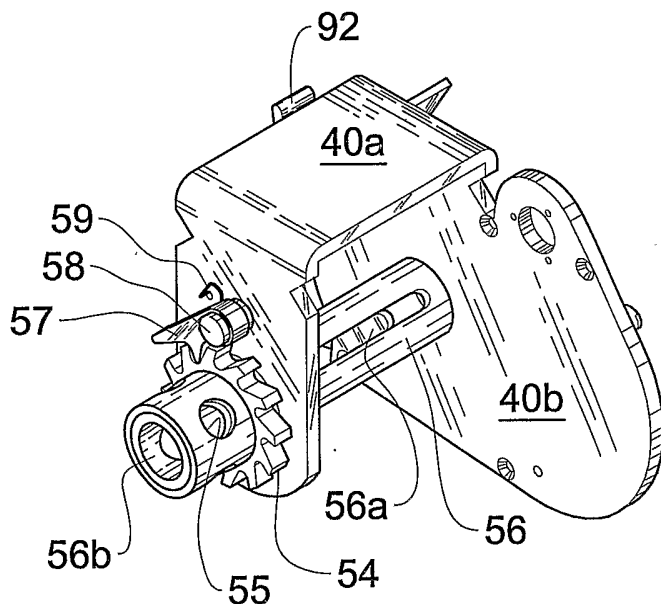

Fig. 5

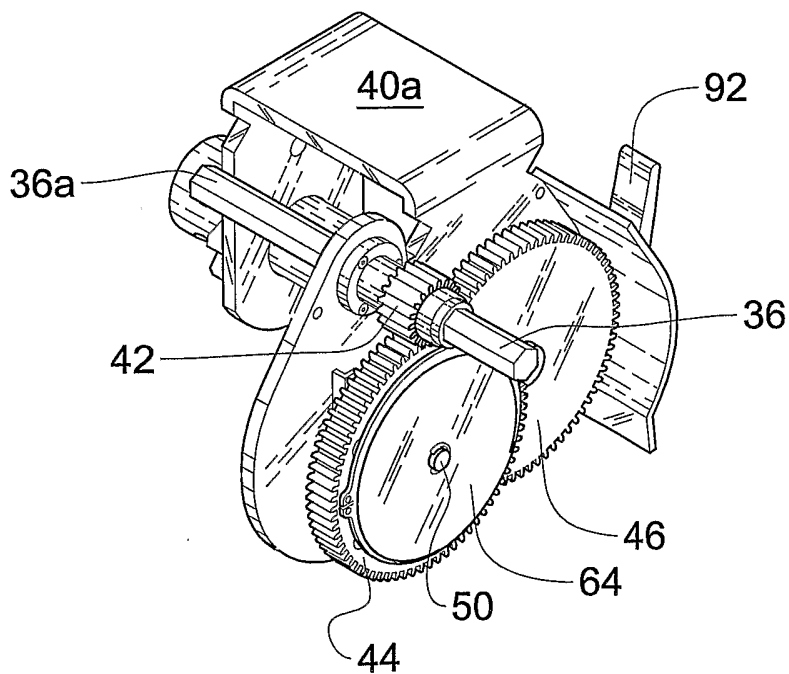

Fig. 4

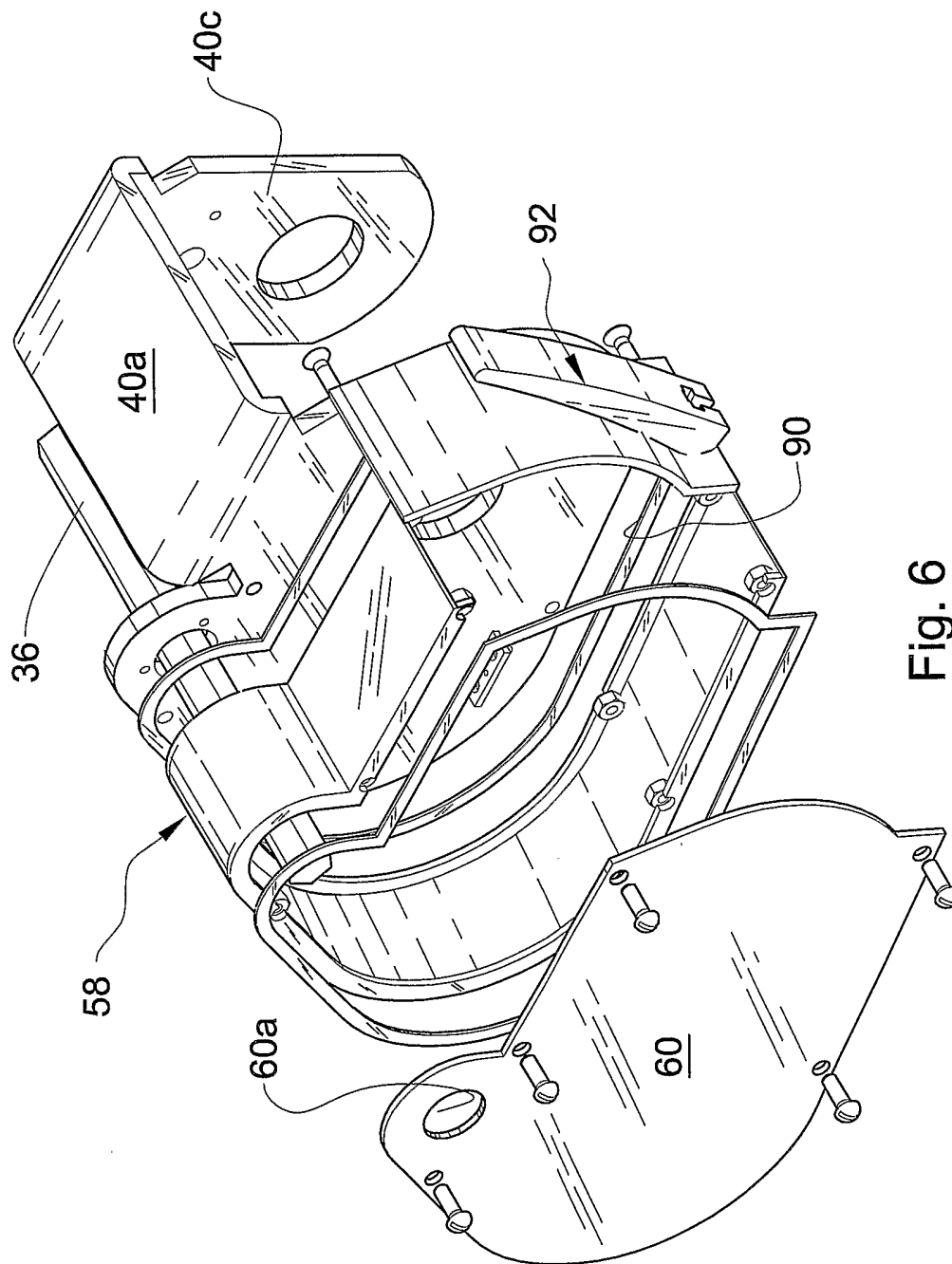

Fig. 6

5/18

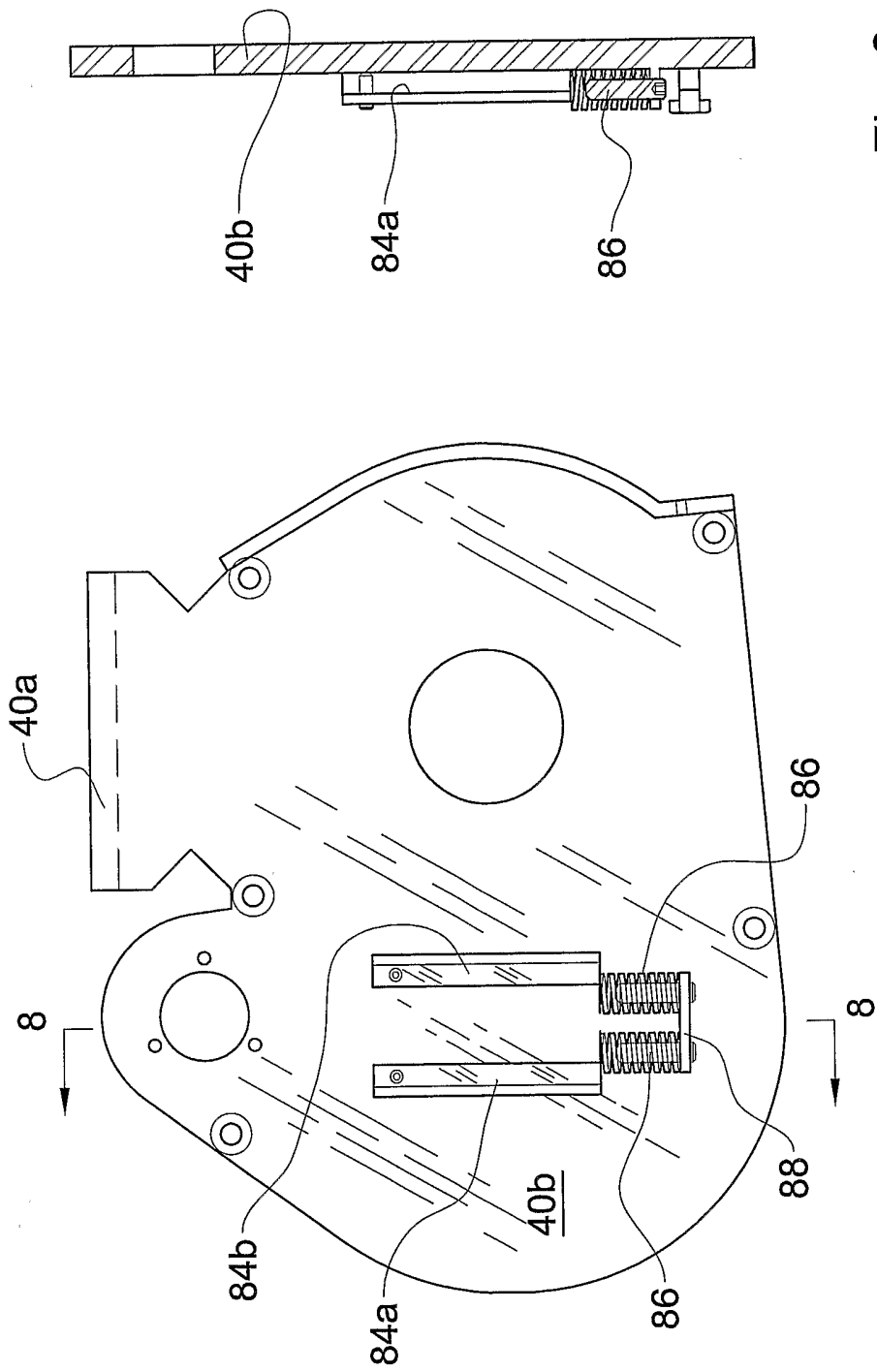

Fig. 8

Fig. 7

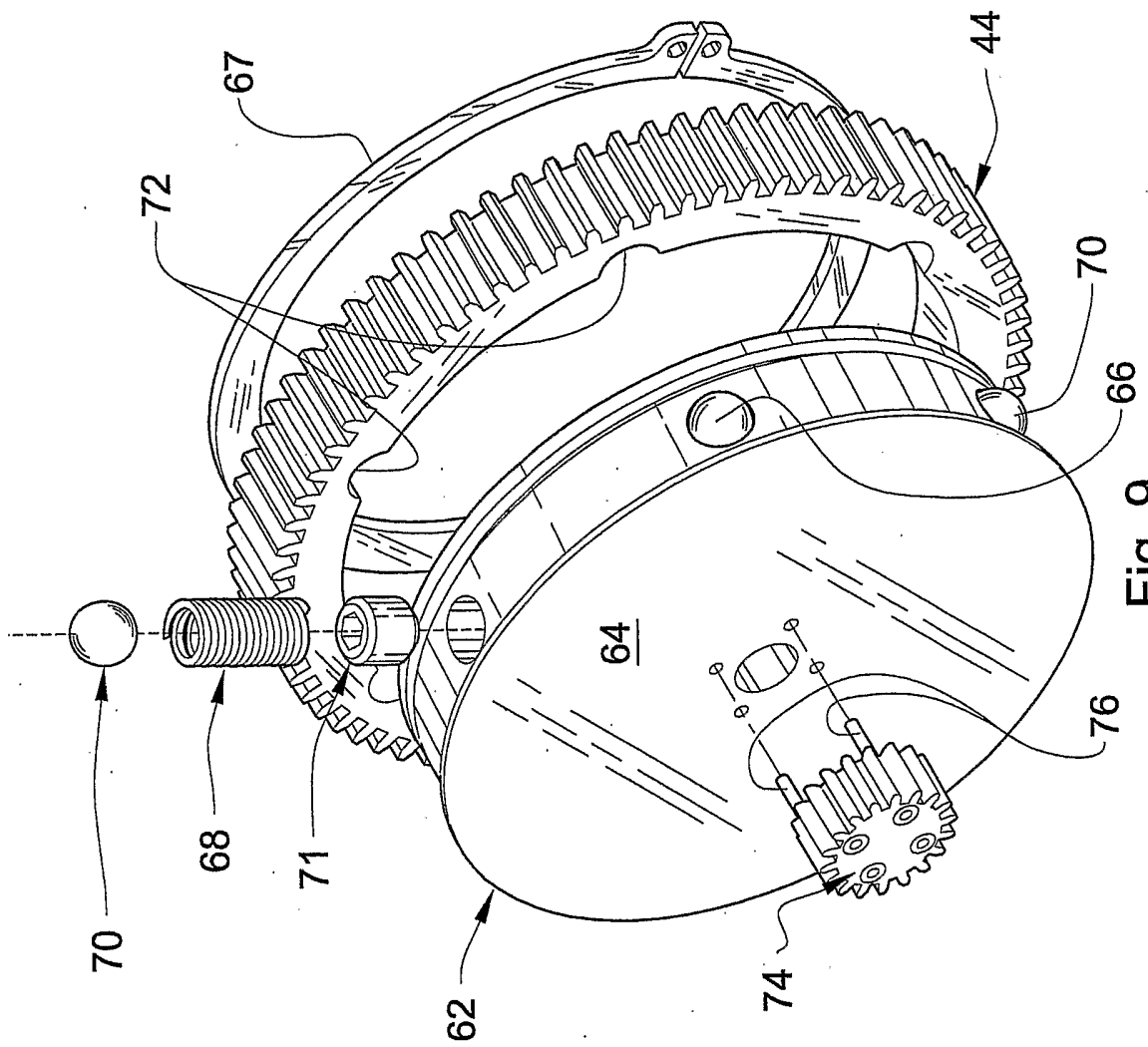

Fig. 9

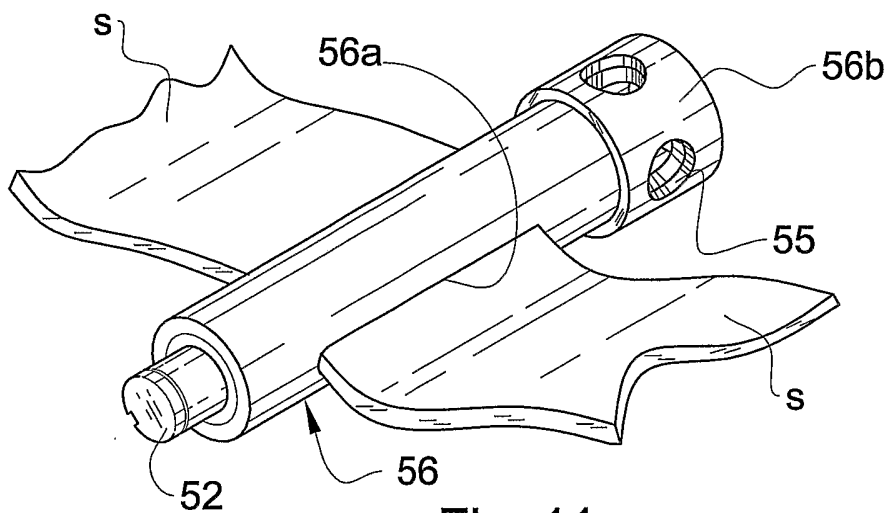

Fig. 11

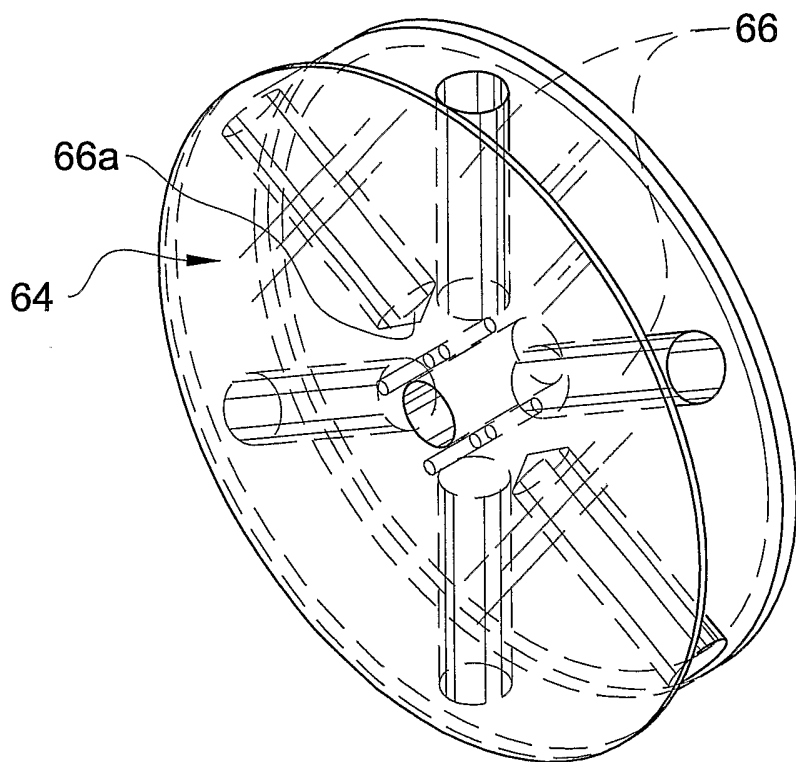

Fig. 10

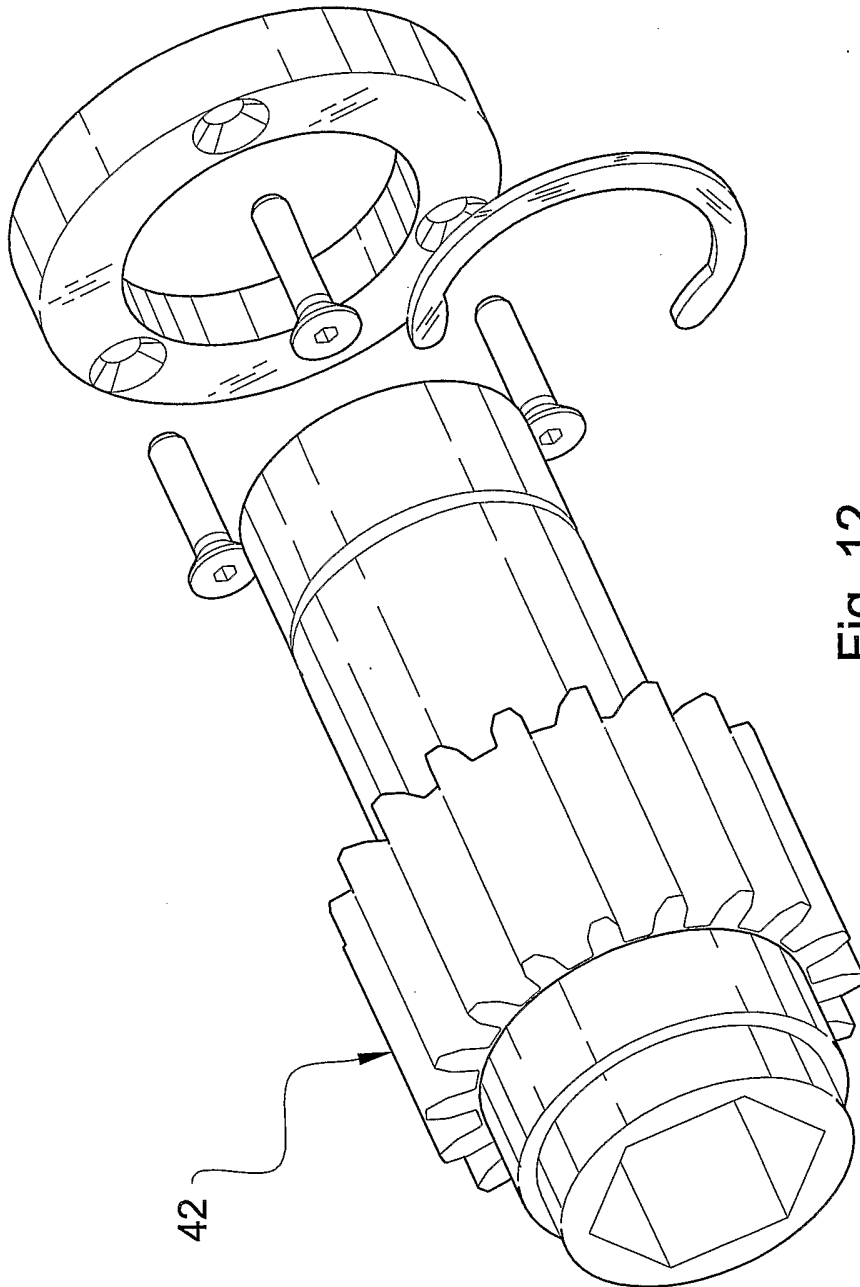

Fig. 12

9/18

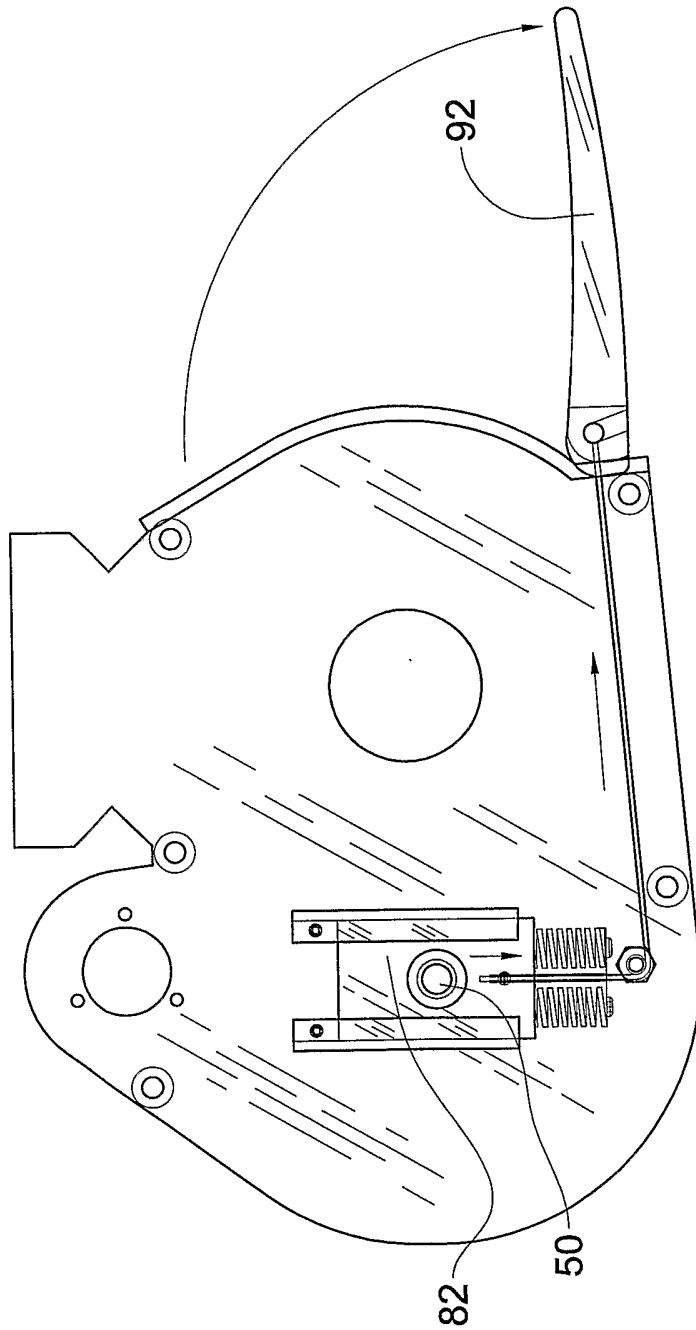

Fig. 13a

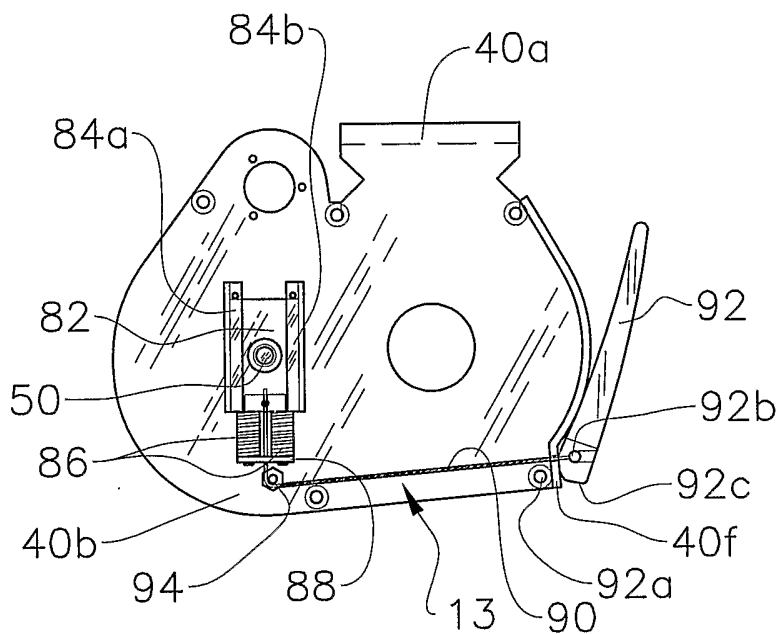

Fig. 13

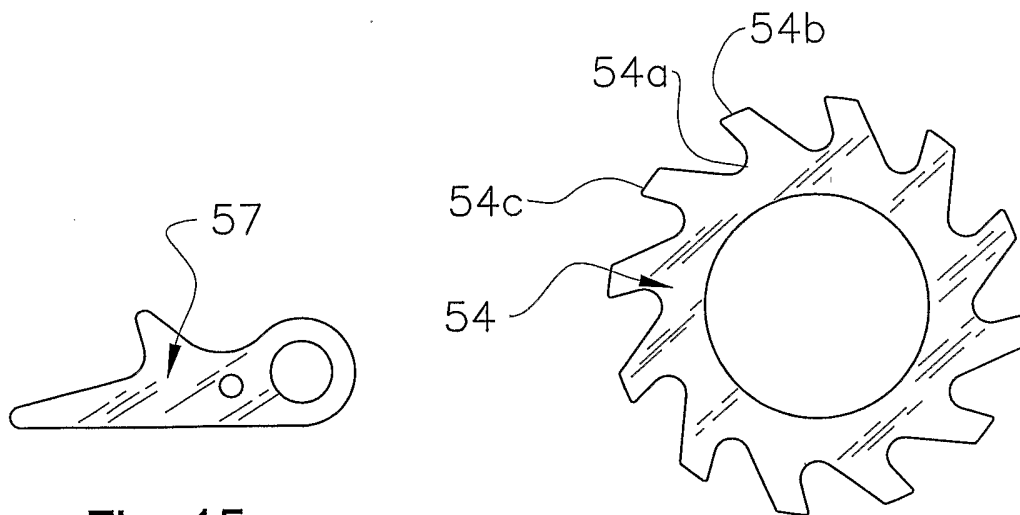

Fig. 15

Fig. 14

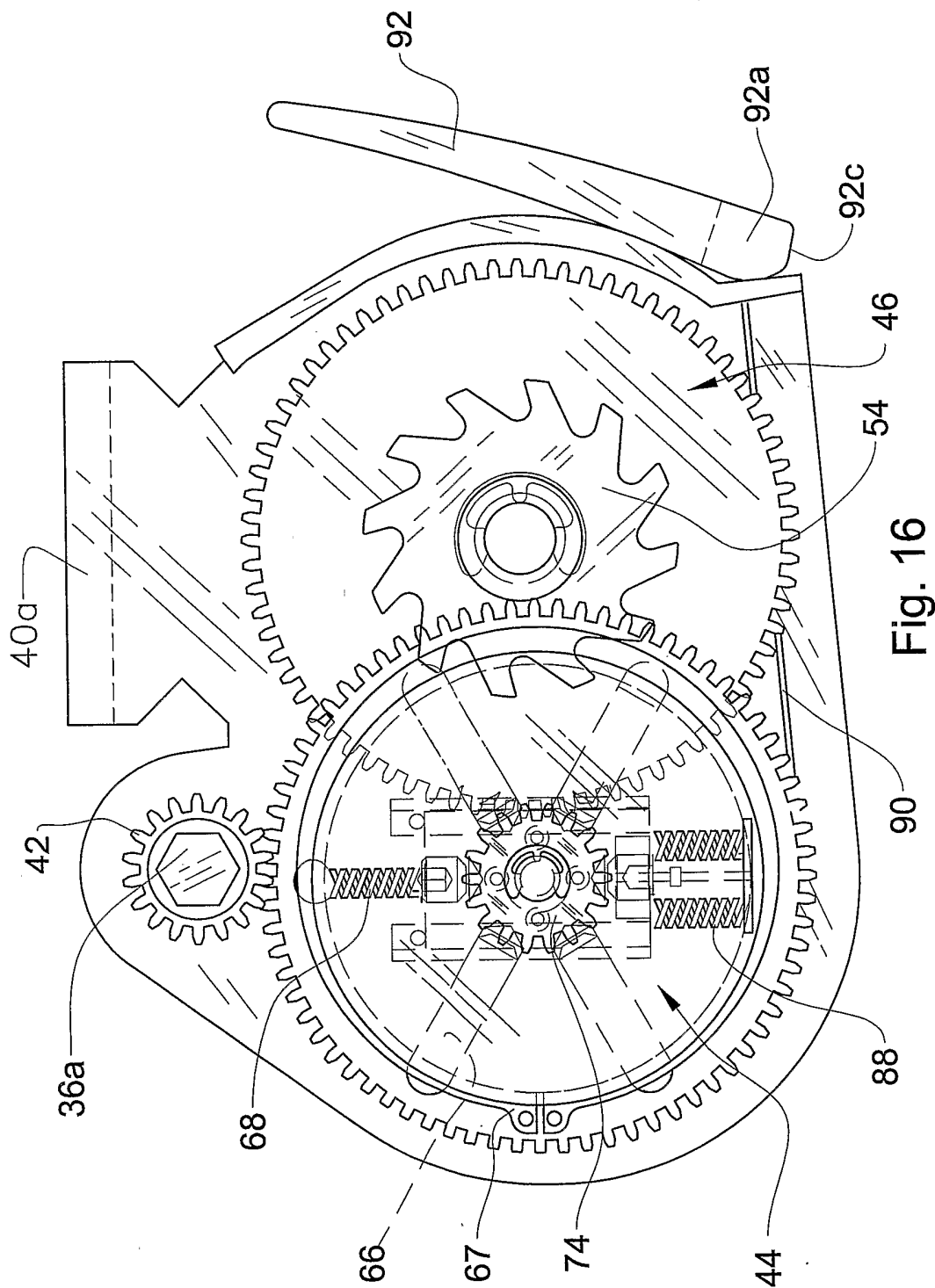

Fig. 16

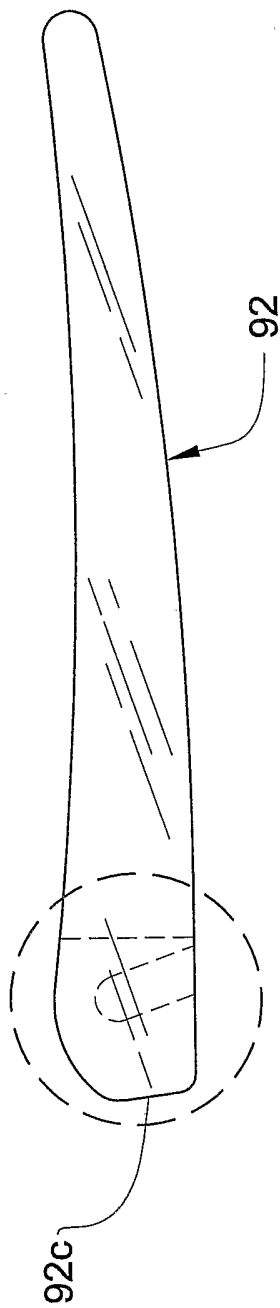

Fig. 17

13/18

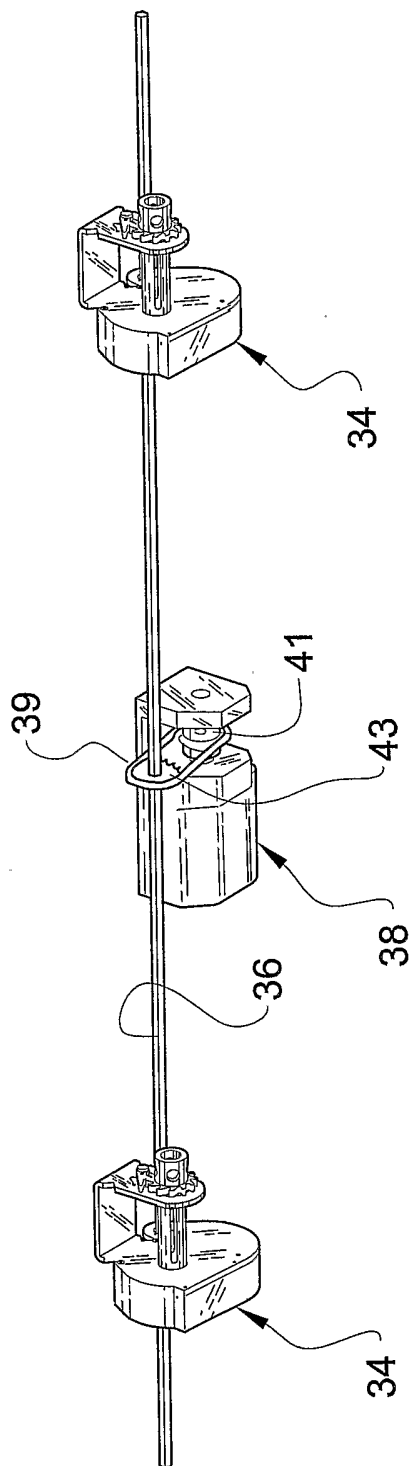

Fig. 18

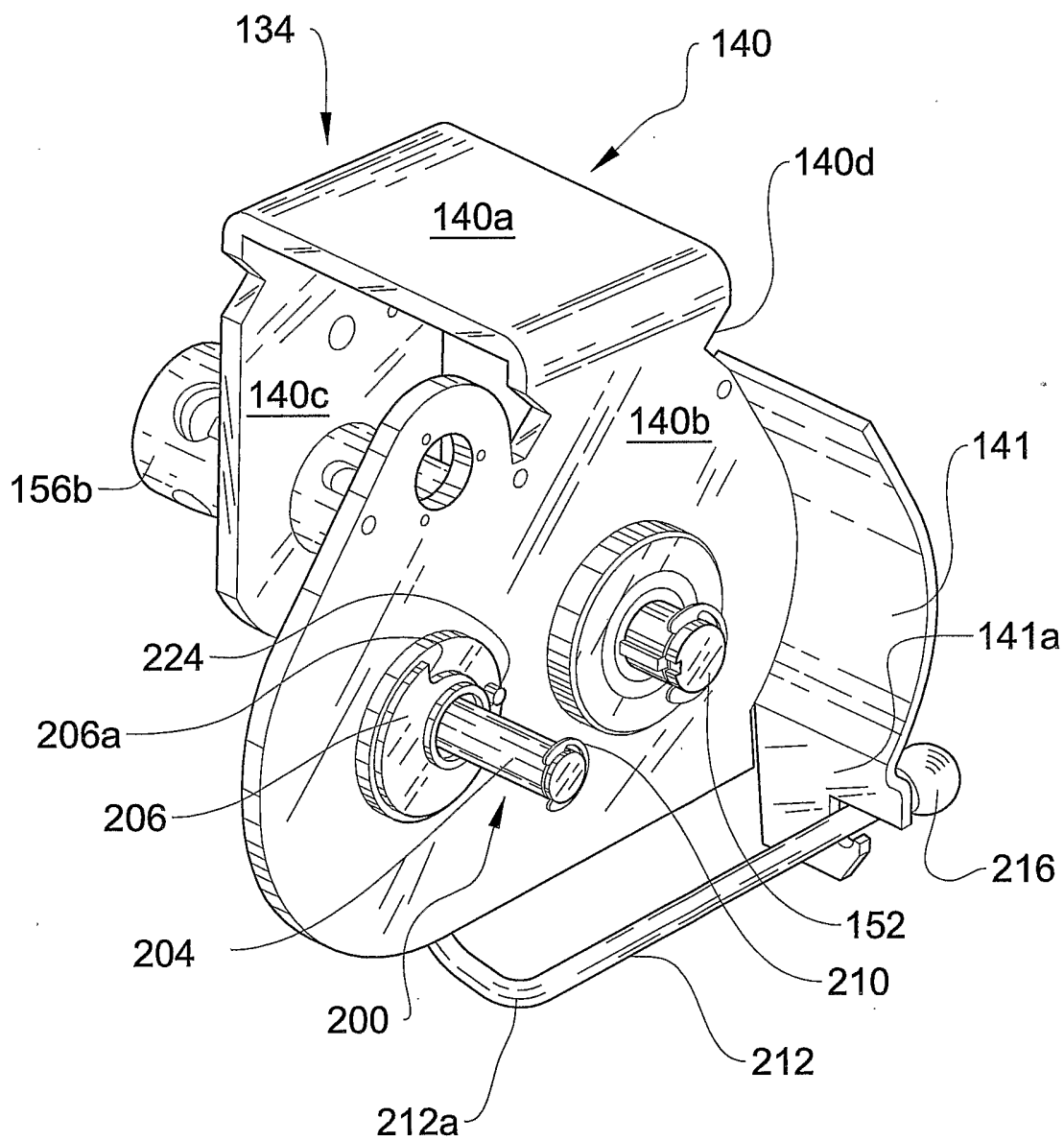

Fig. 19

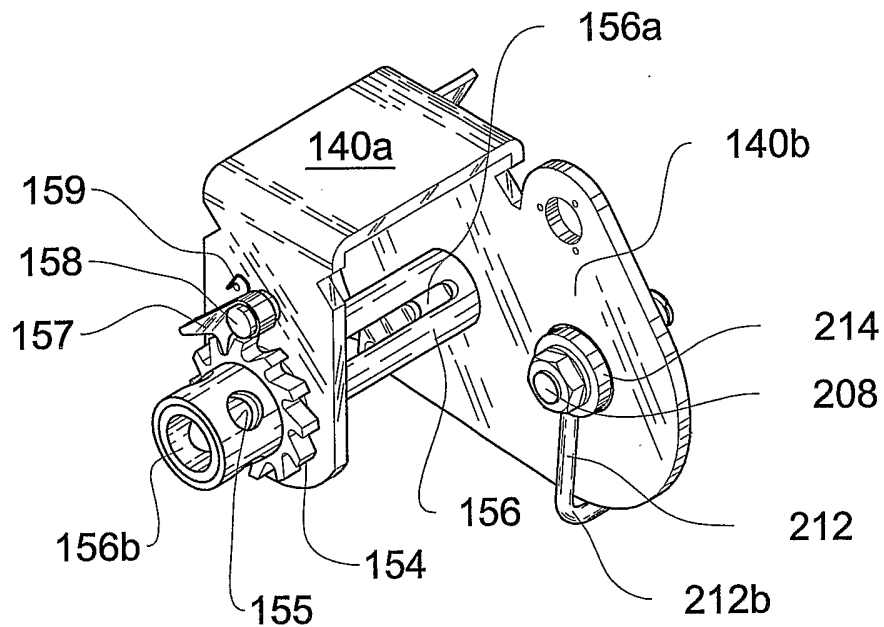

Fig. 20

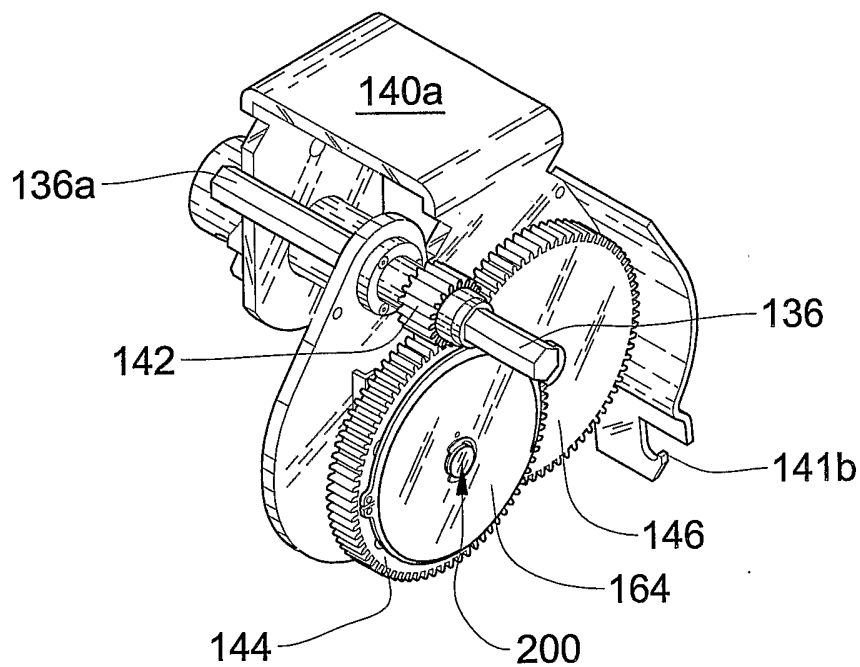

Fig. 21

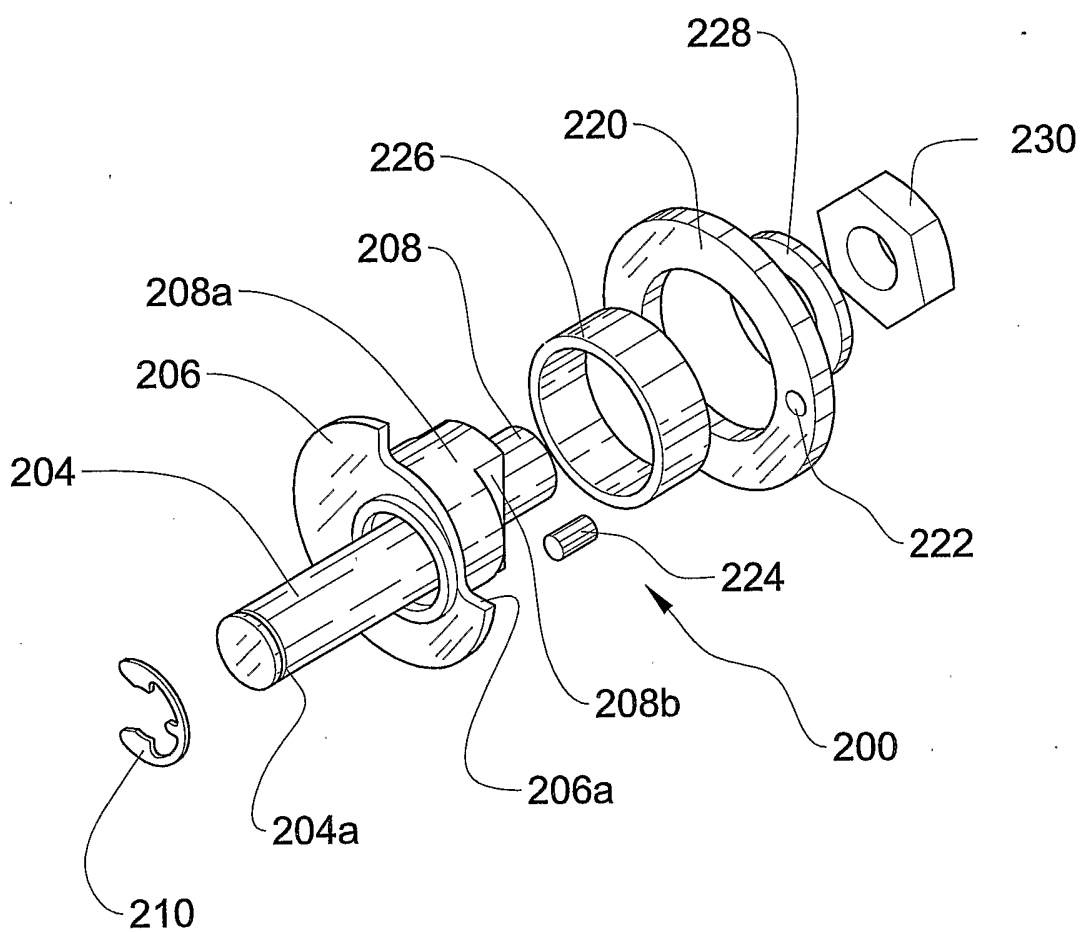

Fig. 22

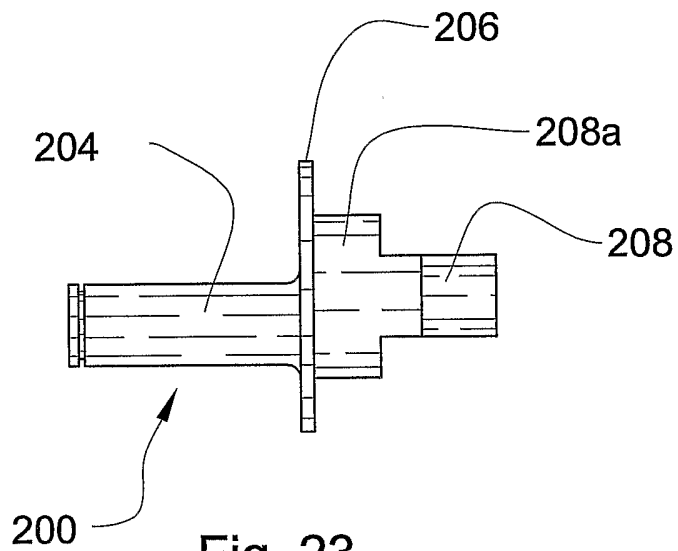

Fig. 23

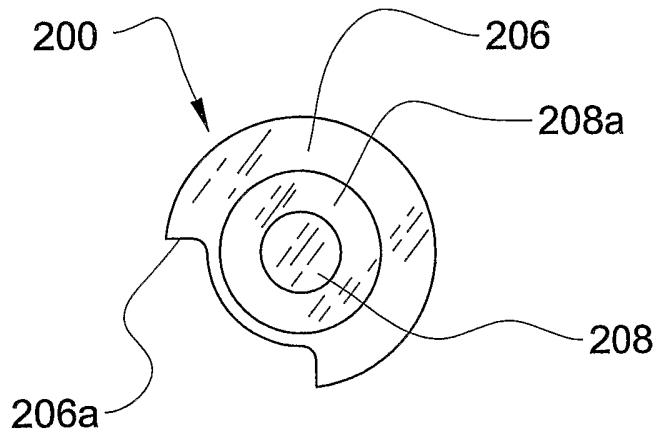

Fig. 24

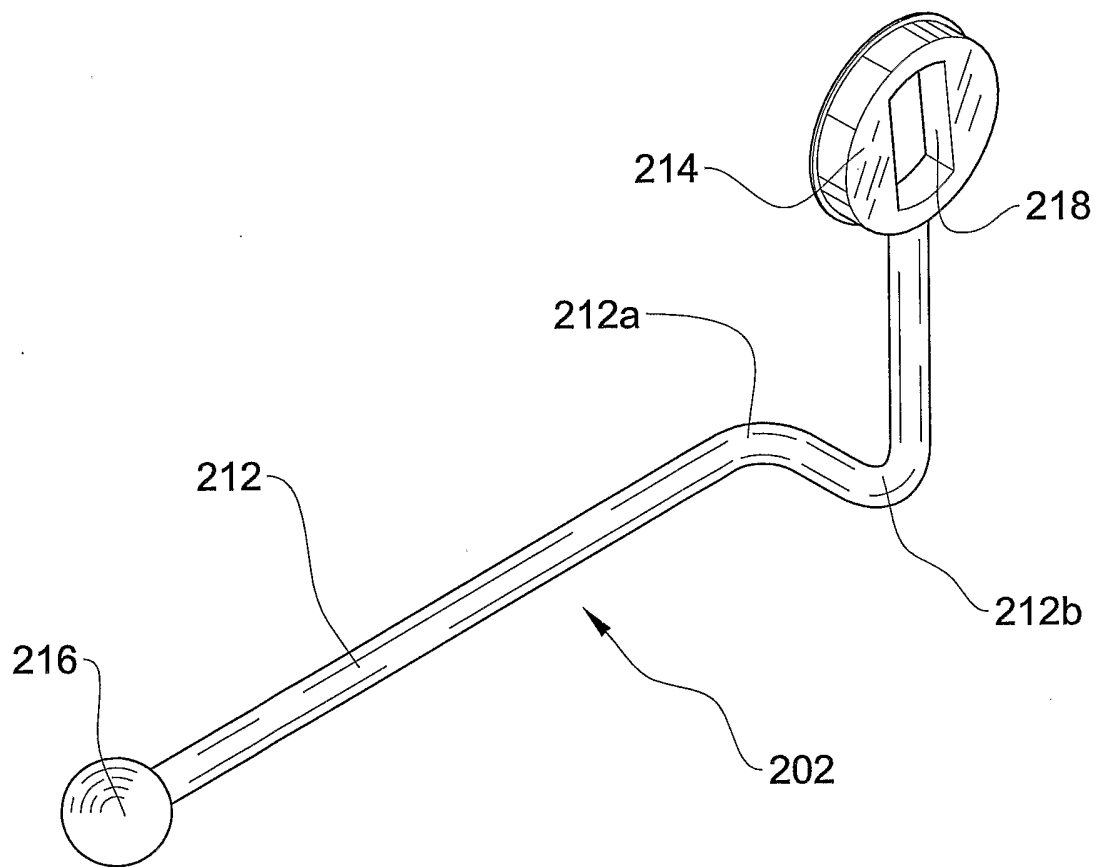

Fig. 25

INTERNATIONAL SEARCH REPORT

International Application No

PCT/CA 02/01189

A. CLASSIFICATION OF SUBJECT MATTER
 IPC 7 B60P7/08 B66D1/16

According to International Patent Classification (IPC) or to both national classification and IPC

B. FIELDS SEARCHED

Minimum documentation searched (classification system followed by classification symbols)
 IPC 7 B60P B66D

Documentation searched other than minimum documentation to the extent that such documents are included in the fields searched

Electronic data base consulted during the international search (name of data base and, where practical, search terms used)

WPI Data, EPO-Internal

C. DOCUMENTS CONSIDERED TO BE RELEVANT

| Category ° | Citation of document, with indication, where appropriate, of the relevant passages | Relevant to claim No. |
|------------|--|-----------------------|
| A | GB 2 128 574 A (BAUMGARTEN NILS BORJE VALENTIN) 2 May 1984 (1984-05-02) page 1, line 75-105 page 2, line 16-27 page 2, line 53-75 page 2, line 89-128 figure 1 figure 5 figure 3 claim 9 | 1,2,5,7, 8,11,18 |
| A | US 5 295 664 A (KAEMPER HANS-WERNER) 22 March 1994 (1994-03-22) column 2, line 11-16 column 2, line 22-28 column 5, line 7-24 figures 1,2 | 1,11 |

Further documents are listed in the continuation of box C.

Patent family members are listed in annex.

° Special categories of cited documents:

- *A* document defining the general state of the art which is not considered to be of particular relevance
- *E* earlier document but published on or after the international filing date
- *L* document which may throw doubts on priority claim(s) or which is cited to establish the publication date of another citation or other special reason (as specified)
- *O* document referring to an oral disclosure, use, exhibition or other means
- *P* document published prior to the international filing date but later than the priority date claimed

- *T* later document published after the international filing date or priority date and not in conflict with the application but cited to understand the principle or theory underlying the invention
- *X* document of particular relevance; the claimed invention cannot be considered novel or cannot be considered to involve an inventive step when the document is taken alone
- *Y* document of particular relevance; the claimed invention cannot be considered to involve an inventive step when the document is combined with one or more other such documents, such combination being obvious to a person skilled in the art.
- *Z* document member of the same patent family

Date of the actual completion of the international search

21 October 2002

Date of mailing of the international search report

30/10/2002

Name and mailing address of the ISA

European Patent Office, P.B. 5818 Patentlaan 2
 NL - 2280 HV Rijswijk
 Tel. (+31-70) 340-2040, Tx. 31 651 epo nl,
 Fax: (+31-70) 340-3016

Authorized officer

Thanbichler, P

INTERNATIONAL SEARCH REPORT

International Application No

PCT/CA 02/01189

C.(Continuation) DOCUMENTS CONSIDERED TO BE RELEVANT

| Category ° | Citation of document, with indication, where appropriate, of the relevant passages | Relevant to claim No. |
|------------|---|-----------------------|
| A | US 5 002 259 A (MANNING DAVID J ET AL) 26 March 1991 (1991-03-26) claims 1,5,7,15,20 figures 3-5 ---- | 1,5,11, 18 |
| A | US 5 573 091 A (HUNG MICHAEL) 12 November 1996 (1996-11-12) column 1, line 8-12 column 3, line 44-53 claims 1,2; figures 2,5,6 ---- | 1,5,6, 11,18 |
| A | US 3 697 045 A (FARLEY HOLT A) 10 October 1972 (1972-10-10) abstract column 1, line 6-14 column 2, line 19-40 ---- | 1-4,7-11 |
| A,P | US 6 350 088 B1 (PRIESTER JAMES D) 26 February 2002 (2002-02-26) abstract column 1, line 8-22 claim 1 figures 1,2 column 3, line 14-30 ----- | 1-4,8-11 |

INTERNATIONAL SEARCH REPORT

Information on patent family members

International Application No

PCT/CA 02/01189

| Patent document cited in search report | | Publication date | Patent family member(s) | Publication date |
|---|----|---------------------|----------------------------|---------------------|
| GB 2128574 | A | 02-05-1984 | SE 438126 B | 01-04-1985 |
| | | | DE 3337184 A1 | 10-05-1984 |
| | | | FI 833617 A ,B, | 16-04-1984 |
| | | | NO 833743 A ,B, | 16-04-1984 |
| | | | SE 8205861 A | 16-04-1984 |
| US 5295664 | A | 22-03-1994 | AT 109734 T | 15-08-1994 |
| | | | CA 2035870 A1 | 04-01-1991 |
| | | | WO 9100196 A1 | 10-01-1991 |
| | | | DE 59006774 D1 | 15-09-1994 |
| | | | EP 0441906 A1 | 21-08-1991 |
| | | | JP 3011761 B2 | 21-02-2000 |
| | | | JP 4500636 T | 06-02-1992 |
| | | | NO 910765 A ,B, | 27-02-1991 |
| US 5002259 | A | 26-03-1991 | NONE | |
| US 5573091 | A | 12-11-1996 | NONE | |
| US 3697045 | A | 10-10-1972 | CA 954382 A1 | 10-09-1974 |
| | | | DE 2222746 A1 | 07-12-1972 |
| | | | FR 2137737 A5 | 29-12-1972 |
| | | | GB 1359602 A | 10-07-1974 |
| | | | NL 7205816 A | 14-11-1972 |
| US 6350088 | B1 | 26-02-2002 | NONE | |