

(19) **DANMARK**



Patent- og
Varemærkestyrelsen

(10) **DK/EP 3241969 T3**

(12) **Oversættelse af
europæisk patentskrift**

-
- (51) Int.Cl.: **E 05 F 15/77 (2015.01)** **E 05 F 15/70 (2015.01)**
- (45) Oversættelsen bekendtgjort den: **2024-02-12**
- (80) Dato for Den Europæiske Patentmyndigheds bekendtgørelse om meddelelse af patentet: **2023-09-06**
- (86) Europæisk ansøgning nr.: **17165418.9**
- (86) Europæisk indleveringsdag: **2017-04-07**
- (87) Den europæiske ansøgnings publiceringsdag: **2017-11-08**
- (30) Prioritet: **2016-05-06 DE 202016002975 U**
- (84) Designerede stater: **AL AT BE BG CH CY CZ DE DK EE ES FI FR GB GR HR HU IE IS IT LI LT LU LV MC MK MT NL NO PL PT RO RS SE SI SK SM TR**
- (73) Patenthaver: **Marantec Marienfeld GmbH & Co. KG, Remser Brook 11, 33428 Harsewinkel/Marienfeld, Tyskland**
- (72) Opfinder: **HÖRMANN, Michael, Bokeler Str. 22, 33790 Halle/Westfalen, Tyskland**
- (74) Fuldmægtig i Danmark: **Zacco Denmark A/S, Arne Jacobsens Allé 15, 2300 København S, Danmark**
- (54) Benævnelse: **STYREENHED TIL ET PORTDREV**
- (56) Fremdragne publikationer:
DE-A1- 19 650 569
DE-C2- 3 515 945
DE-U1- 29 723 253
DE-U1-202007 002 606
DE-U1-202008 009 618
US-A1- 2015 148 983
US-A1- 2015 262 438

Control unit for a door drive

The invention relates to a control unit for a door drive comprising at least one microprocessor for executing door control commands, at least one control panel for operating and programming the control unit, and at least one display element for displaying information relevant for programming.

Door drives consist of mechanical, electrical, and electronic components. The electronic components include for example sensors, display elements, input keyboards, and control units. The electronic control unit comprises at least one microprocessor and at least one memory component. A software executed on the microprocessor takes over the monitoring and control of the door drive. The software contains program runs that can be programmed in an application-specific manner.

Pre-programmed functions and parameters are often selected and specified via the control panel and the display element when door systems are brought into operation. The available functions and parameters are usually summarised in selection menus, and can be easily configured by users.

Basic functions, such as the determination of the specific door position in the open/closed position, can be configured. Door travel speeds or functions of connected command elements can also be set. Parameters for setting the drive force, the force limitation or the travel time limitation can also be selected or modified. Furthermore, activation of accessories is made possible. Thus, for example various sensors can be connected, and can be activated and parameterised in the control unit. Passage light barriers, light grids or displacement sensors can be individually configured immediately. In addition to these basic functions, functions and parameters that are relevant for safety can also be set.

Door drives of the type in question, comprising a corresponding control unit, are known from US 2015/0262438 A1 and DE 20 2008 009618 U1.

In order to protect the door function and to prevent incorrect configuration settings, these safety-relevant settings, but also some of the basic functions, should be able to be viewed or set only by trained specialist staff. For this reason, there is a need for access control for the setting of particular functions and parameters, and for the activation of accessories.

This object is achieved by a control unit for a door drive according to the features of claim 1. The dependent claims relate to advantageous embodiments of the control unit.

The invention proceeds from a control unit of the type in question for a door drive, which comprises at least one microprocessor for executing door control commands, at least one control panel for operating and programming the control unit, and at least one display element for displaying information essential for programming. Information essential for programming includes any visualisation of programming settings of the control unit or the door drive that are necessary for the door operation. Said programming settings are taken into account by the microprocessor in the actuation of the door drive.

The information can be displayed in menu form. The control panel makes it possible to select individual items of information, and to directly manipulate these configuration data.

According to the invention, a communication means is provided in the control unit, in order to communicate with at least one suitable access module. The microprocessor is programmed in such a way that it permits or prevents a modification and/or display of programming settings depending on the communication with the access module. The access module thus functions as a type of access key for the specialist staff. As soon as the communication connection between the microprocessor and access module is established, the microprocessor can allow access to the desired basic functions and/or safety-relevant functions.

Safety-relevant programming settings, as well as basic programming settings of the door drive, can thus be made only if the operator has what is known as an access module. Without said access module, such possibilities for setting would not be enabled by the control unit and preferably also not displayed on the display element.

According to the invention, the control unit comprises a suitable slot for receiving the access module, which is itself designed as a plug-in module. Via the slot, what is known as a BUS connection of the access module to an internal BUS interface of the control unit, for example via RS-485 protocol, is achieved.

The access module comprises a memory in which information essential for programming is stored. The microprocessor of the control unit can access said relevant information via the communication means and, based thereon, enable or deactivate corresponding programming settings for display and/or programming.

In addition, an individual identification code is also stored within the memory of the access module, which code can be accessed by the microprocessor via the communication means. In this case, it is conceivable that the corresponding activation information is not stored on the access module itself, but rather that the control unit or the microprocessor comprises an internal database which contains information, for each individual identification code of an access module that has been read out, regarding which programming settings can be displayed and/or modified for the respective identification code. For example, a stepped display and/or modification possibility of individual programming commands can be achieved depending on the respective identification code.

According to the invention, following each successful display and/or modification of a program setting the previously read-out identification code of the identified access module is stored in an event memory of the control unit. It thus remains possible to trace which modifications have been made by which user.

The programming settings that can be enabled, which are activated or can be

displayed depending on the identified access module, may be parameters for the setting of the open or closed door position, i.e. the specific door position in the open or closed position of the door. It is also conceivable for the programming settings to constitute parameters of the door travel speed and/or the drive force and/or the force limitation and/or the travel time limitation of the door drive. Likewise, safety-critical settings**TN can be included under the above-mentioned term of programming settings.

The programming settings that can be enabled can furthermore be functions of connected command elements, such as the integration and parameterisation of one or more integrated handheld radio transmitters or other operating elements. An activation and parameterisation of further accessories, such as additional sensors, inter alia a passage light barrier and/or a light grid and/or one or more displacement sensors, are also conceivable.

In addition to the control unit according to the invention, the present invention also relates to a door drive comprising a corresponding control unit according to the present invention.

Lastly, the invention relates to a door, in particular a garage door or an industrial door, comprising a door drive according to the present invention. The door can be designed as a sliding or revolving door, a sectional door, a roller door, a tilting door, etc.

Further advantages and properties of the invention will be explained in greater detail in the following, with reference to an embodiment shown in the drawings,

in which:

Fig. 1: shows the control unit according to the invention comprising a plugged-in access module, and

Fig. 2: shows the control unit according to the invention with the access module removed.

Fig. 1 is a detailed view of the control unit according to the invention. A base unit 15 comprising the display element 11 and the control panel 12 is visible. Individual programming or configuration parameters of the control unit can be displayed on the display element. This can take place in particular by means of a menu-like display. The selection and modification of the programming settings or the configuration parameters is carried out via the control panel 12. By means of the parameters, the door drive can be configured individually to the door type used in each case and the application purpose.

A communication unit 16, which provides necessary interfaces for communication with external devices, is positioned on the base unit 15. The communication unit 16 comprises, inter alia, a slot 13 for insertion of an access module 14. In addition to this, further slots or connection points are available, which, however, will not be discussed in greater detail.

The access module 14, designed as a plug-in module, can be plugged into the slot 13. Said access module 14 comprises an internal memory which contains an individual identification code. If the access module 14 is plugged into the associated slot 13, the central microprocessor of the control unit 10 can read out the access identification number of the access module 14 via the communication module 16. Furthermore, data essential for programming can be contained on the internal memory of the access module 14, which data contain information regarding which programming settings of the control unit 10 are to be enabled or can be displayed via the display element 11 and should be able to be manipulated via the control panel 12.

The microprocessor reads out said data from the memory of the access module 14, and controls the respective display or modification possibility.

Alternatively, it is conceivable that the memory of the access module 14 merely bears an identification code which is read out by the microprocessor via the communication module 16. The microprocessor can then evaluate, in an internal database, what

programming settings off the identification code, read out in each case, should be able to be modified or displayed.

Furthermore, in the case of each display or modification of a programming setting of the control unit 10, the respective identification number of the plugged access module 14 can be stored in an internal event memory, such that it is also possible to trace, in the future, which modifications were made by which user or access module 14.

The slot 13 can additionally be designed as what is known as a universal slot which, in addition to the access module 14, can also receive at least one other device designed as a plug-in module, preferably an antenna designed as a plug-in board.

The data of the access module, i.e. the identification code and/or the information essential for programming, can be stored encrypted in the memory. Furthermore, the communication connection between the control unit and the access module can take place in an encrypted manner.

Patentkrav

1. Styreenhed (10) til et portdrev med mindst en mikroprocessor til udførelse af portstyringskommandoer, mindst et styrepanel (12) til at betjene og programmere styreenheden (10), mindst et displayelement (11) til at vise information essentielt for programmering, såvel som mindst et adgangsmodulet (14), hvor et kommunikationsorgan er tilvejebragt til at kommunikere med det mindst ene adgangsmodulet (14), der virker som en adgangsnøgle, hvor mikroprocessoren, afhængigt af kommunikationen med adgangsmodulet (14), tillader eller forhindrer en modifikation og/eller visning af programmeringsindstillinger for styreenheden (10), hvor adgangsmodulet (14) omfatter en hukommelse med programmeringsrelevant information der kan tilgås af mikroprocessoren via kommunikationsorganet, og hvor den programmeringsrelevante information indeholder en definition af programmeringsindstillingerne for styreenheden, som skal aktiveres til modifikation og/eller visning,

15 **kendetegnet ved,**

at kommunikationsorganet er konfigureret som en udvidelsesport (13) til modtagelse af adgangsmodulet (14) konfigureret som et indstiksmodulet og kommunikation er udført via en BUS-grænseflade, eksempelvis ved hjælp af RS-485,

20 **at** adgangsmodulet (14) omfatter en hukommelse, der kan tilgås af mikroprocessoren via kommunikationsorganet, i hvilket en identifikationskode er lagret, og

at mikroprocessoren sammenligner identifikationskoden modtaget fra adgangsmodulet (14) med en intern hukommelse og på baggrund af sammenligningen validerer programmeringsindstillinger for modifikation og/eller visning.

2. Styreenhed (10) ifølge krav 1, **kendetegnet ved, at** identifikationskoden kan sendes til mikroprocessoren via kommunikationsorganet og kan lagres i en hændeshukommelse af styreenheden, så snart en ændring og/eller visning af programmeringsindstillinger finder sted.

3. Styreenhed (10) ifølge et hvilket som helst af de foregående krav, **kendetegnet ved, at** de aktiverbare programmeringsindstillinger er parametre til indstilling af portpositionen åben/lukket og/eller portens bevægelseshastighed og/eller drivkraften og/eller kraftbegrænsningen og/eller bevægelsestidsbegrænsningen og/eller kritiske sikkerhedsindstillinger.
- 5
4. Styreenhed (10) ifølge et hvilket som helst af de foregående krav, **kendetegnet ved, at** de aktiverbare programmeringsindstillinger er funktionen af forbundne kommandoelementer og/eller aktiveringen og parametriseringen af tilbehør, såsom yderligere sensorer, i særdeleshed en gennemgangslysbarriere og/eller et lysgitter og/eller en eller flere bevægelsessensorer.
- 10
5. Portdrev omfattende en styreenhed (10) ifølge et hvilket som helst af de foregående krav.
- 15
6. Port, i særdeleshed en garageport eller industriport, omfattende et portdrev ifølge krav 5.

Fig. 1

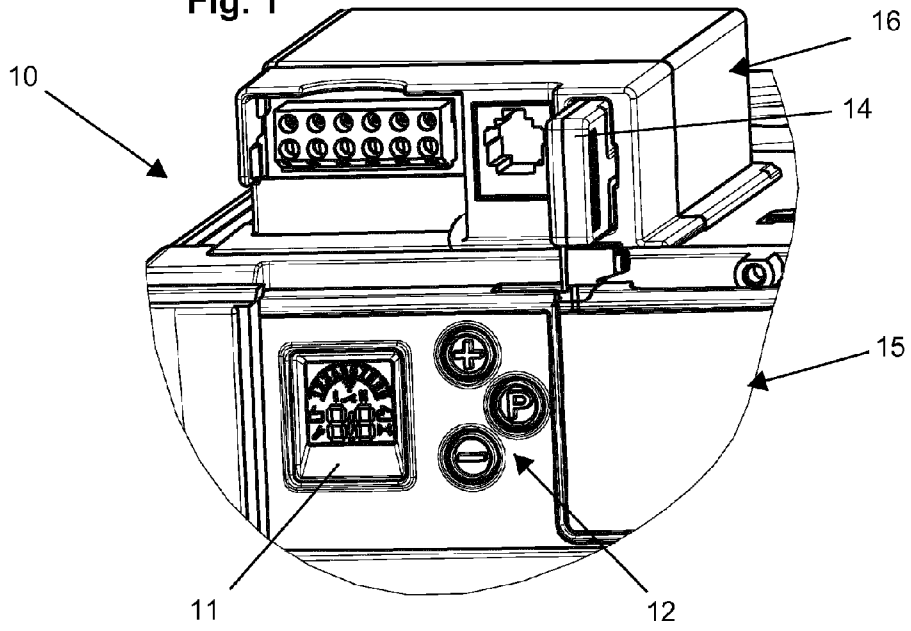

Fig. 2

