



Europäisches Patentamt
European Patent Office
Office européen des brevets



(11) **EP 0 744 509 A1**

(12) **EUROPEAN PATENT APPLICATION**

(43) Date of publication:
27.11.1996 Bulletin 1996/48

(51) Int Cl.⁶: **E04B 9/30, E04B 9/00**

(21) Application number: **96201288.6**

(22) Date of filing: **10.05.1996**

(84) Designated Contracting States:
AT BE CH DE DK ES FR GB LI LU NL PT

(72) Inventor: **Van Geel, Jacobus Antonius Peter
5281 JX Boxtel (NL)**

(30) Priority: **12.05.1995 NL 1000356**

(74) Representative: **Hoorweg, Petrus Nicolaas et al
Arnold & Siedsma,
Advocaten en Octrooigemachtigden,
Sweelinckplein 1
2517 GK Den Haag (NL)**

(71) Applicant: **VAN GEEL SYSTEMS B.V.
NL-5281 RS Boxtel (NL)**

(54) **Suspension device for ceiling panels**

(57) A device for suspending ceiling panels, which panel at least consists of a body plate (3) having standing wall parts (4) which are arranged at least in the corner thereof and which enclose a mutual angle, wherein the panel is suspended in a support frame using suspension means, wherein the suspension means consist

of a pin-like member (21) which is carried through two plate-like supports (12,13) for placing at a mutual distance in the corner and which (21) protrudes beyond the standing wall part (4) of the panel, whereby a very simple and therefore inexpensive suspension construction is obtained with which the panels can easily be fitted and removed.

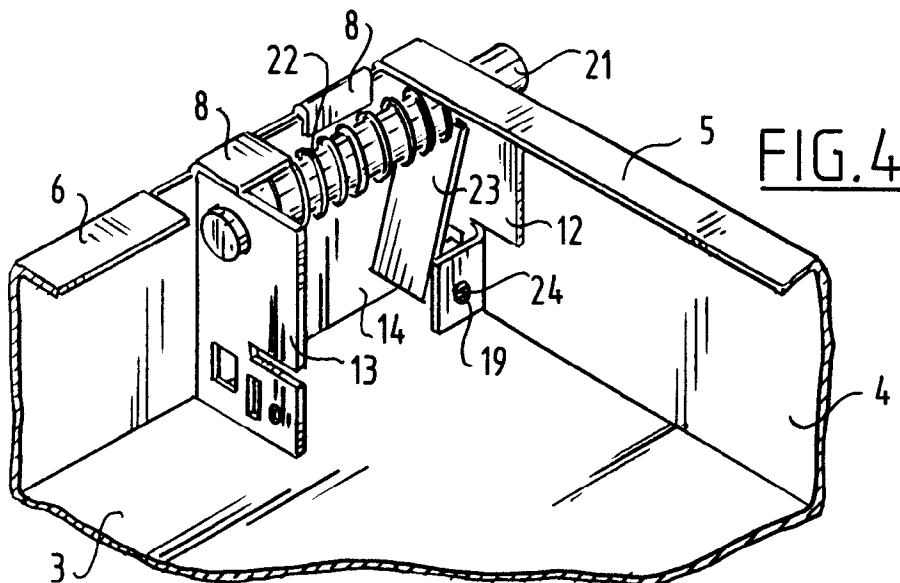

EP 0 744 509 A1

Description

The invention relates to a device for suspending ceiling panels, which panel at least consists of a body plate having standing wall parts which are arranged at least in the corner thereof and which enclose a mutual angle, wherein the panel is suspended in a support frame using suspension means.

Many suspension devices for ceiling panels are already known, which however all have the drawback of a construction which is complicated and thereby difficult to manufacture.

The invention has for its object to improve the suspension device for panel-like ceiling elements such that it is necessary to work with only a minimum number of different components to suspend the element, but such that the element can be released and swung aside.

The device according to the invention is distinguished in that the suspension means consist of a pin-like member which is carried through two plate-like supports for placing at a mutual distance in the corner and which protrudes beyond the standing wall part of the panel.

In a further development the two plate-like supports are fixed to each other to form a U-shaped sub-frame. This sub-frame can be placed by means of simple fastening members in the corner portion of the panel in both a "left-hand" and "right-hand" embodiment.

It is hereby possible to use the sub-frame as pivoting support provided with a fixed pin-like member or as lock, in which case a movable pin-like member is arranged.

Above mentioned and other features of the invention will be further elucidated in the figure description hereinbelow of an embodiment. In the drawing:

fig. 1a-f show in each case a perspective bottom view of a ceiling in a random space, which ceiling is embodied with panel-like ceiling elements,

fig. 2 shows a perspective view of a detail of the corner of the panel-like ceiling element of fig. 1,

fig. 3a, b show a perspective view corresponding with fig. 2 of the corner part of the ceiling element provided with a sub-frame with fixed pin-like member,

fig. 4 shows a perspective view corresponding with fig. 2 provided with a pin-like member movable in axial sense as a lock,

fig. 5a, b and c show a perspective view of the locking system of fig. 4 in dismantled state and as a left-hand mounted and right-hand mounted pin-like member.

In fig. 1 the space R is embodied with a ceiling P, which ceiling consists of a plurality of panel-like ceiling elements 1 in mutually adjacent arrangement. These elements are suspended in a suspension frame 2, consisting here for instance of angle beams, which can be

arranged in the space R in random manner. Such ceiling panels 1 must not only be capable of easy fitting in suspension frame 2 but must also be releasable in order to enable replacement of the elements or to make the space above the ceiling panels accessible, for instance for work on conduits and the like.

The panel-like ceiling element comprises a flat body part having in the embodiment shown a rectangular peripheral form, along which periphery standing wall parts 4 are arranged to form a cassette-like panel.

The standing wall parts 4 enclose at the corners an angle of 90° but it will be apparent that with a different peripheral form other angle settings can be realized.

The right angle between the standing wall parts 4 is shown in detail in fig. 2-4.

Fig. 2 shows that the standing wall parts 4 are provided on the edge remote from body plate 3 with an inward bent flange 5, 6, wherein flange 6 has recesses 7 for the purpose of forming bending lips 8.

In the standing wall part 4 not provided with bending lips 8 are arranged respective openings 9 and 10, the function of which is further elucidated below.

In order to enable suspension of the ceiling elements 1, suspension means in the form of a fixed pin, see fig. 3a, 3b, or a slidable pin, see fig. 4, 5, are arranged in the corners.

Fig. 3a and 3b show that a fixed pin in the form of a bolt can be carried through the hole 9 and through two support plates 12, 13 arranged at a mutual distance. The support plates 12, 13 are mutually connected by a plate 14 such that a U-shaped sub-frame is formed. Each plate 12, 13 is provided with a hole 15 which coincides with the hole in the standing wall 4 placed in the sub-frame in the corner.

Each support plate 12, 13 is provided with holes 16 corresponding with the holes 10 in fig. 2 in addition to incisions 17 respectively 18 arranged close to these holes 16, and a hole 19.

Mounting of the fixed bolt 11 takes place by sliding the sub-frame into the corner of the panel-like element such that the hole 15 is in register with the hole 9 in standing wall 4.

The bending lip 8 is folded inward against the inside of plate 14, whereby the sub-frame is fixed into the corner. The bolt 8 is subsequently fastened to the left-hand support plate 13 in fig. 3b by means of two nuts 20. The bolt head of bolt 11 protrudes some distance on the outside of the standing wall 4, see fig. 3b, whereby this bolt head can be fixed to the sub-frame 2 in fig. 1. The bolt head can for instance be hung in a recess of angle profile 2 opening toward the top. Alternatively, a circular hole can be arranged in the angle profile 2 through which the bolt must first be placed prior to being fixed to the sub-frame in the panel-like element.

It will be apparent that two bolts 11 are arranged mutually in line at either end of the rear standing wall part 4 in order to form a pivot axis. The slidable pins 21 can be mounted as according to fig. 4 on the two re-

maining corners of the panel-like ceiling element. The sub-frame consisting of support plates 12, 13 and 14 is once again placed in the corner, wherein however the pin 21 is placed in advance through holes 15, round which pin a pressure spring 22 is arranged, see fig. 5b. Mounted simultaneously with pin 21 is a lever 23 consisting of an L-shaped strip, the short leg of which is embodied with protrusions 24, which are received in the holes 19 of the sub-frame, and a lip 25 which can be placed through hole 10. Fig. 5b further shows that fitting of lever 23 takes place by bending the lower portion of support plate 12 respectively 13, depending on the left-hand or right-hand embodiment, see fig. 5b and c. The lip 25 protrudes through the hole 10 of the standing wall parts 4 so that it is accessible from outside.

The sub-frame with arranged pin and lever as according to fig. 5b and c is fixed in the same manner in the corners of a ceiling panel using the bending lip. For fitting of the ceiling panel it is only necessary to press against the lip 25 with an auxiliary tool, for instance a pressing plate 30 in fig. 1b, 1c, to cause the lever 23 to tilt on the tilt axis through the holes 19. The strip 23 which fits into a recess 26 of pin 21 presses the pin inward counter to the action of pressure spring 22. The ceiling panel can thus be placed flush with the angle profiles 2 and, by releasing the lip 25, the pressure spring 22 will push back pin 21 into a recess prearranged in the angle profiles 2. In this manner the ceiling panel is fixed. The ceiling panel can also be swung aside again by carrying out the reverse operation, which is shown in fig. 1e and f.

The invention is not limited to the above described embodiments.

Claims

1. Device for suspending ceiling panels, which panel at least consists of a body plate having standing wall parts which are arranged at least in the corner thereof and which enclose a mutual angle, wherein the panel is suspended in a support frame using suspension means, **characterized in that** the suspension means consist of a pin-like member which is carried through two plate-like supports for placing at a mutual distance in the corner and which protrudes beyond the standing wall part of the panel.
2. Device as claimed in claim 1, **characterized in that** the supports are the legs of a U-shaped sub-frame.
3. Device as claimed in claim 2, **characterized in that** the pin-like body is received slidably in the legs and is biased by a tensioning member.
4. Device as claimed in claim 3, **characterized in that** the legs are provided with holes to support and allow passage of a control lever which engages the pin-like body.

5. Device as claimed in claim 2, **characterized in that** the legs have local incisions to obtain bending lips.

6. Device as claimed in claims 1 and 2, **characterized in that** the standing wall part is provided with a bent flange which is interrupted locally to form one or more bending lips for fixing of the sub-frame.

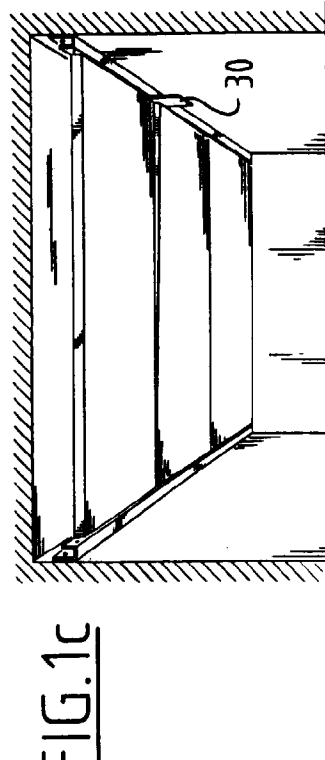
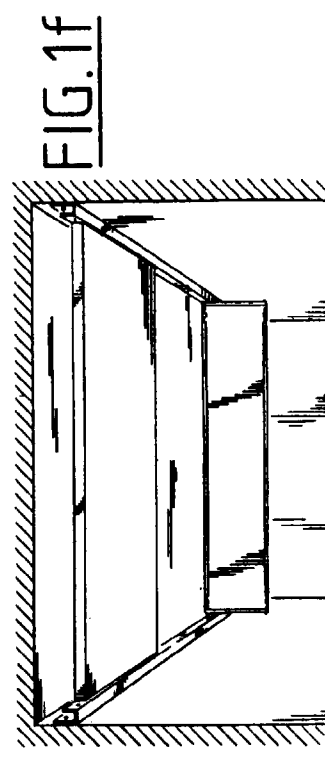
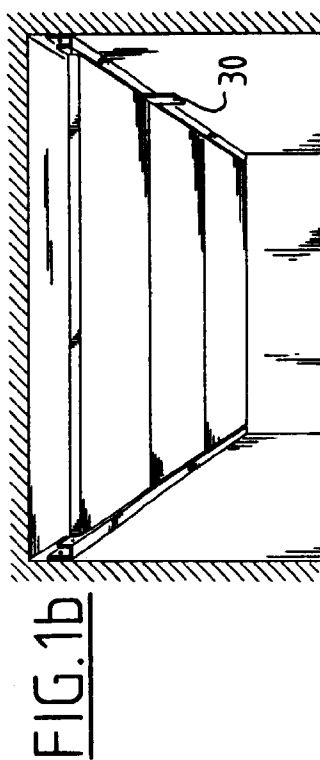
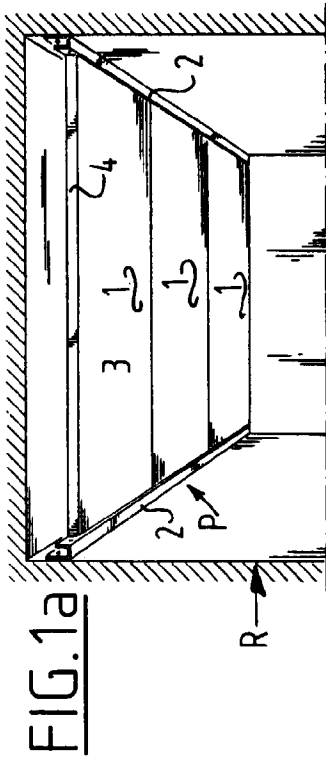
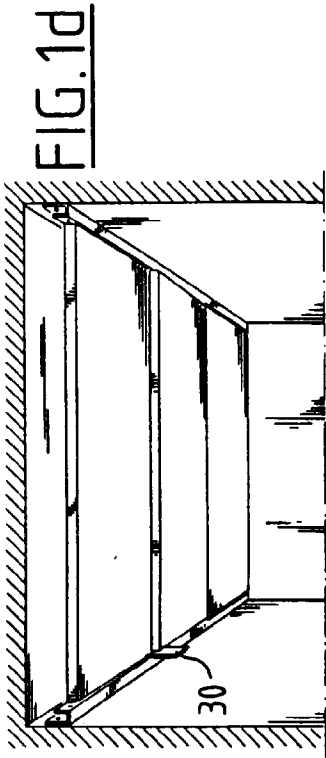

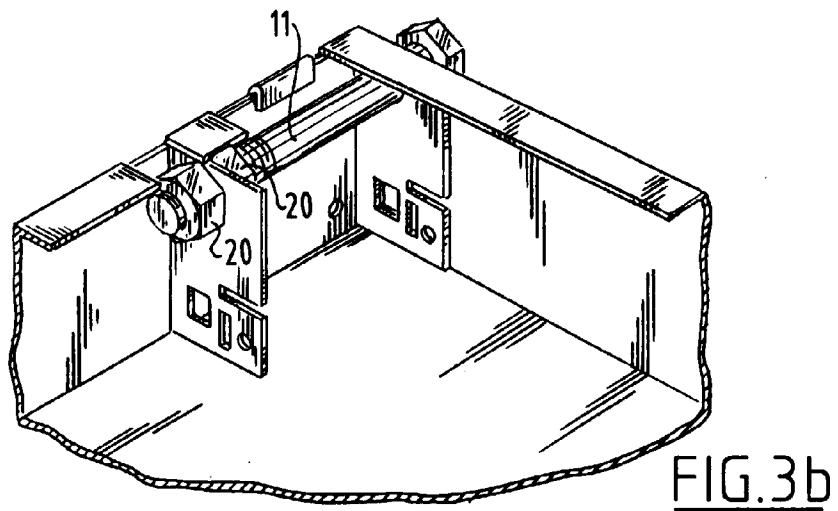
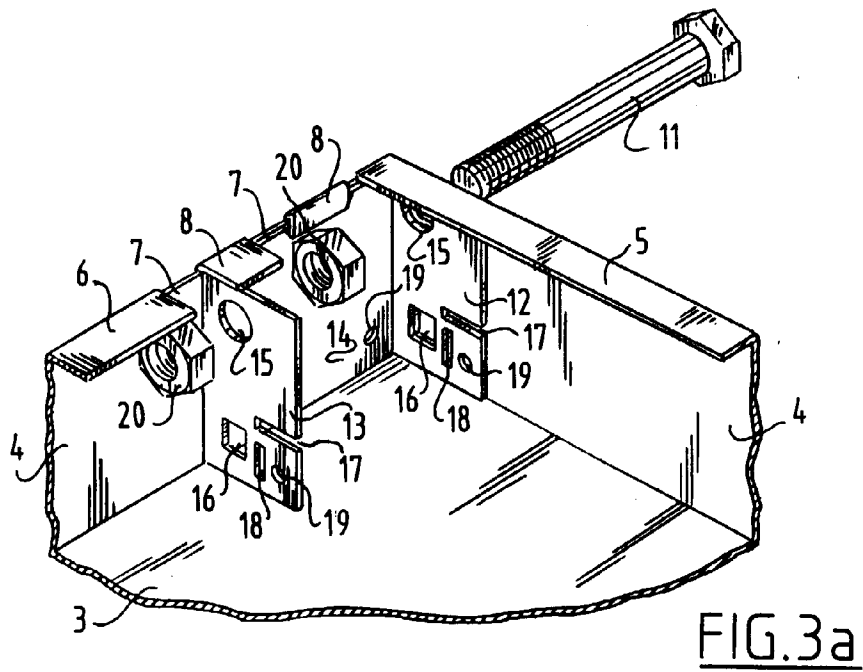
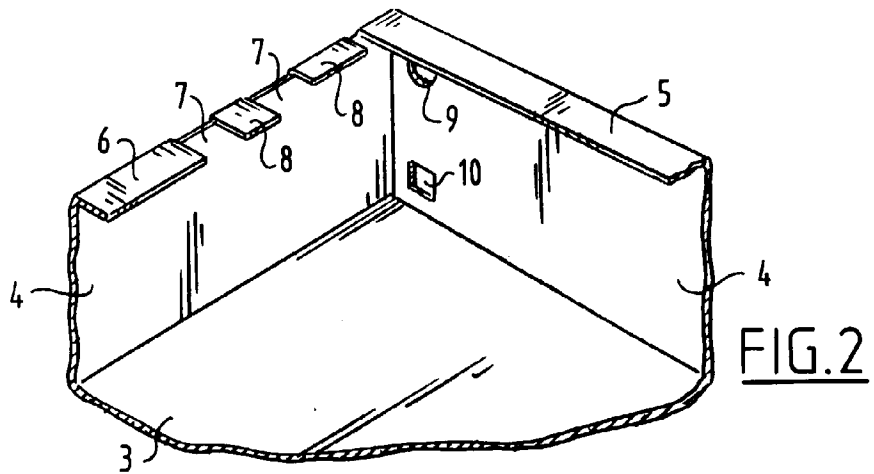

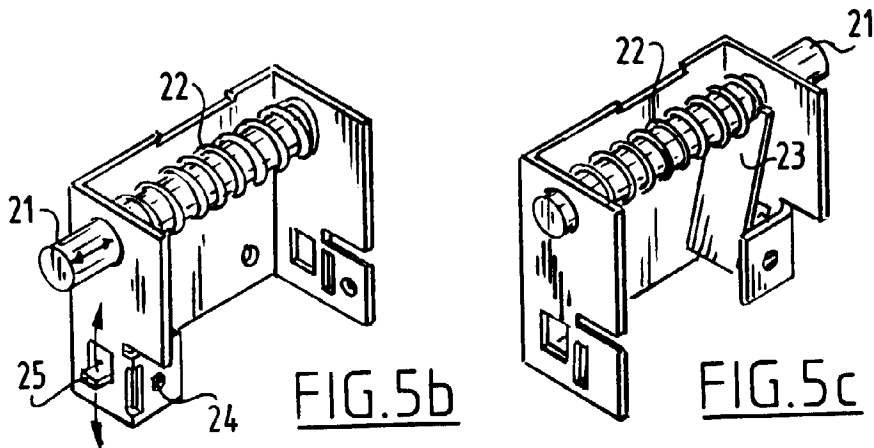
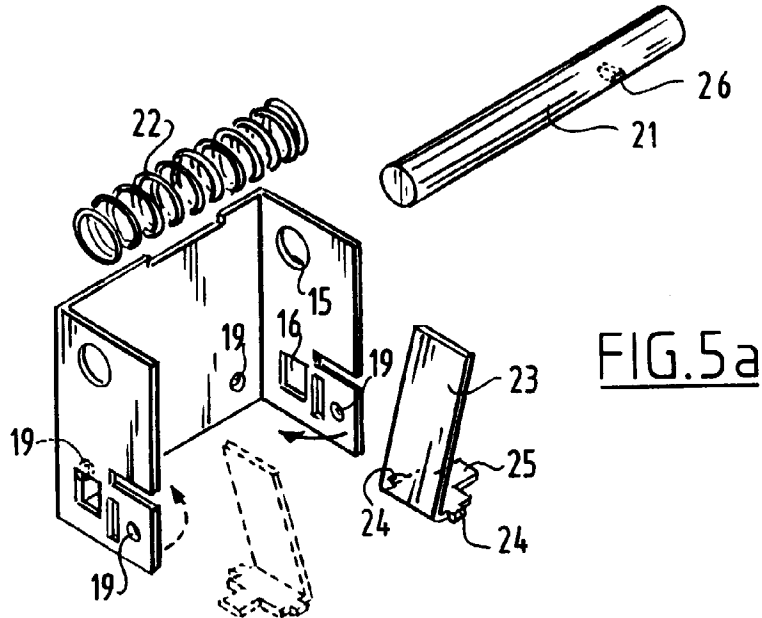
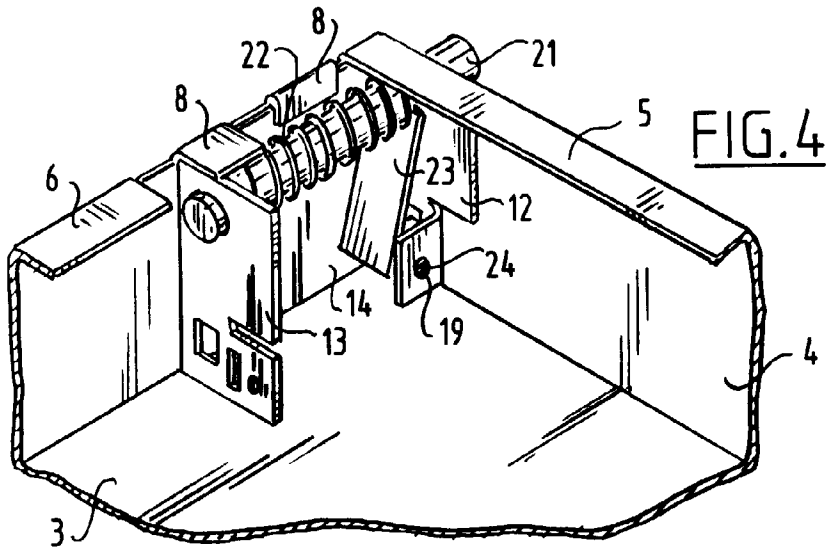



European Patent
Office

EUROPEAN SEARCH REPORT

Application Number
EP 96 20 1288

DOCUMENTS CONSIDERED TO BE RELEVANT			
Category	Citation of document with indication, where appropriate, of relevant passages	Relevant to claim	CLASSIFICATION OF THE APPLICATION (Int.Cl.6)
X	DE-U-90 04 023 (DIG DEUTSCHE INNENBAU) 21 June 1990	1-3	E04B9/30 E04B9/00
Y	* page 1, paragraph 3 * * page 6, paragraph 2 - page 7, paragraph 1 * * figures 1-4 *	4-6	
Y	--- EP-A-0 589 115 (CLESTRA HAUSERMAN) 30 March 1994 * figures 2,3,6-8 *	4	
Y	--- AU-A-7 124 938 (HERMES ENGINEERING PTY.) 10 August 1972 * page 4, paragraph 5 - page 5, paragraph 2 * * figures 1,2 *	5	
Y	--- EP-A-0 616 094 (WILHELMI WERKE) 21 September 1994 * column 3, line 24 - column 3, line 28 * * column 3, line 49 - column 4, line 8 * * figures 1-4 *	6	
			TECHNICAL FIELDS SEARCHED (Int.Cl.6)
			E04B
The present search report has been drawn up for all claims			
Place of search THE HAGUE		Date of completion of the search 24 September 1996	Examiner Hendrickx, X
CATEGORY OF CITED DOCUMENTS		I : theory or principle underlying the invention E : earlier patent document, but published on, or after the filing date D : document cited in the application L : document cited for other reasons & : member of the same patent family, corresponding document	
X : particularly relevant if taken alone Y : particularly relevant if combined with another document of the same category A : technological background O : non-written disclosure P : intermediate document			

EPO FORM 1503 01.82 (P/MC01)