

C. W. TALIAFERRO.

Wheel Cultivator.

No 56,122.

Patented July 3, 1866.

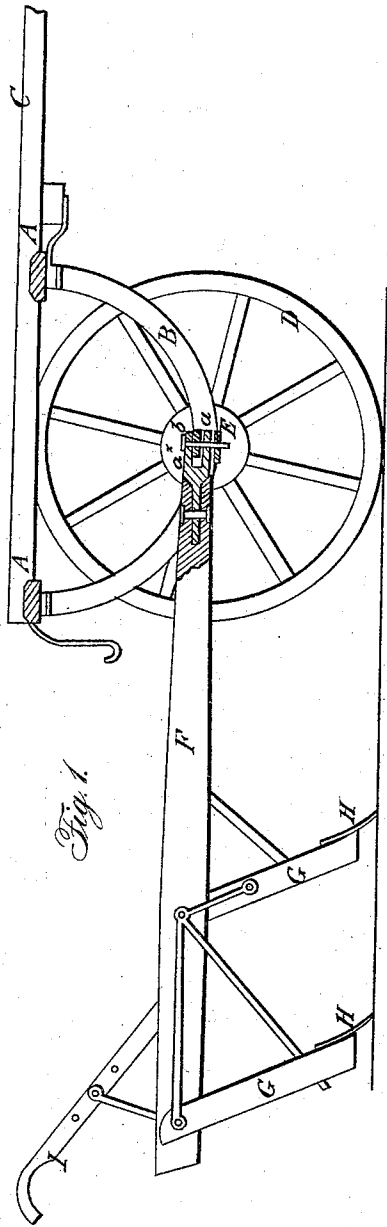
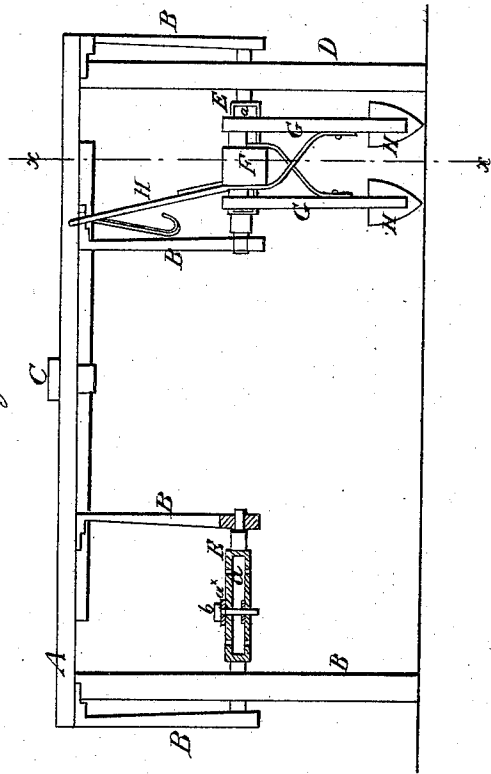

Fig. 2



Witnesses:

*Jas. A. Service  
 W. B. Huntington*

Inventor:

*C. W. Taliaferro  
 Per Munn &  
 Attorneys*

# UNITED STATES PATENT OFFICE.

C. W. TALIAFERRO, OF KEITHSBURG, ILLINOIS.

## IMPROVEMENT IN CORN-CULTIVATORS.

Specification forming part of Letters Patent No. 56,122, dated July 3, 1866.

*To all whom it may concern:*

Be it known that I, C. W. TALIAFERRO, of Keithsburg, Mercer county, State of Illinois, have invented a new and Improved Corn-Cultivator; and I do hereby declare that the following is a full, clear, and exact description thereof, which will enable others skilled in the art to make and use the same, reference being had to the accompanying drawings, forming part of this specification, in which—

Figure 1 is a side sectional view of my invention, taken in the line *x x*, Fig. 2; Fig. 2, a front view of the same, partly in section.

Similar letters of reference indicate like parts.

This invention relates to a new and improved corn-cultivator or corn-plow; and it consists in a novel construction of the same, as hereinafter fully shown and described, whereby the plows may with the greatest facility be adjusted both vertically and laterally, as may be required, and a strong and durable implement obtained.

A A represent two parallel bars, which may be constructed of wood, and are connected by semicircular metal bars B, four of said bars B being used. C is a draft-pole, which is attached centrally to the bars A A at right angles, and D D are the wheels, placed loosely on their axles E E, which are fitted loosely in the bars B at their centers. These axles E E are of rectangular form the greater portion of their length, and they have a slot, *a*, made through the rectangular portion to receive the clevises *a*<sup>x</sup> of plow-beams F F, and these clevises are secured in the slots *a* by means of pins *b*, as shown clearly in Fig. 1, said pins admitting

of the plow-beams being turned or adjusted laterally, while the axles E E, in consequence of being fitted loosely in their bearings, admit of the plow-beams being raised and lowered vertically.

The plow-beams have standards G attached to them in a slightly inclined position, as usual, and these standards have plows H secured to their lower ends, two standards being attached to each beam. Each beam is also provided with a handle, I, to be grasped by the driver or operator, who walks behind the machine.

It will be seen from the above description that the machine may be constructed at a very moderate cost, and still be strong and durable. There are no parts liable to get out of repair or become deranged by use.

Having thus described my invention, I claim as new and desire to secure by Letters Patent—

1. The particular manner of constructing the frame of the machine—to wit, of two parallel bars, A, connected by semicircular metallic bars B, with the axles E fitted between or having their bearings in said bars, substantially as shown, and for the purpose set forth.

2. The connecting of the plow-beams F F to the axles E by having the latter formed with slots *a* to receive clevises *a*<sup>x</sup> at the front ends of the beams, with pins *b* passing through the axles and clevises, substantially as and for the purpose specified.

C. W. TALIAFERRO.

Witnesses:

B. C. TALIAFERRO,  
O. C. RICHARDSON.