



INTERNATIONAL APPLICATION PUBLISHED UNDER THE PATENT COOPERATION TREATY (PCT)

<p>(51) International Patent Classification ⁶ : H04Q 11/04, H04L 29/06</p>	<p>A1</p>	<p>(11) International Publication Number: WO 99/29135 (43) International Publication Date: 10 June 1999 (10.06.99)</p>
<p>(21) International Application Number: PCT/GB98/03501 (22) International Filing Date: 24 November 1998 (24.11.98)</p> <p>(30) Priority Data: 97309810.6 4 December 1997 (04.12.97) EP 98302452.2 30 March 1998 (30.03.98) EP</p> <p>(71) Applicant (for all designated States except US): BRITISH TELECOMMUNICATIONS PUBLIC LIMITED COMPANY [GB/GB]; 81 Newgate Street, London EC1A 7AJ (GB).</p> <p>(72) Inventors; and (75) Inventors/Applicants (for US only): BEDDUS, Simon, Alexander [GB/GB]; 35 Grove Lane, Ipswich, Suffolk, IP4 1NX (GB). BRUCE, Gary, Leslie [GB/GB]; 34 Haughgate Close, Woodbridge, Suffolk IP12 1LQ (GB).</p> <p>(74) Agent: WELLS, David; BT Group Legal Services, Intellectual Property Dept., Holborn Centre, 8th floor, 120 Holborn, London EC1N 2TE (GB).</p>		<p>(81) Designated States: AU, CA, CN, JP, SG, US, European patent (AT, BE, CH, CY, DE, DK, ES, FI, FR, GB, GR, IE, IT, LU, MC, NL, PT, SE).</p> <p>Published <i>With international search report.</i></p>

(54) Title: COMMUNICATIONS NETWORK

(57) Abstract

In a communications network, communications terminals exchange call control capability data which mutually identifies selected call control protocols and network address types. The terminals subsequently set up a call using protocols chosen from those identified. Preferably the terminals continuously monitor for a request for the exchange of such data, allowing other parties to join a session subsequently, after the initial set up.

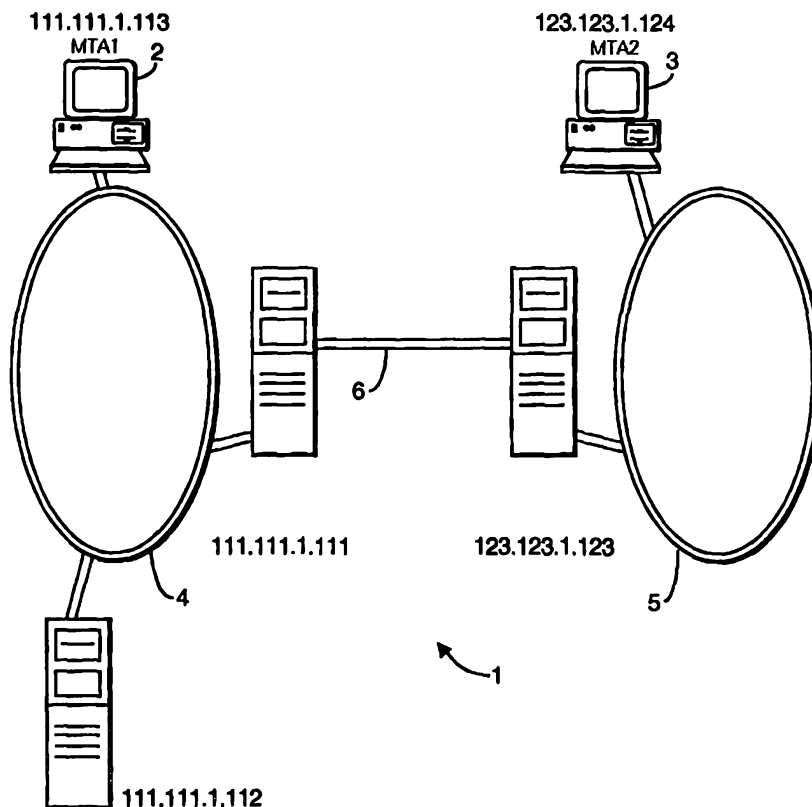

FOR THE PURPOSES OF INFORMATION ONLY

Codes used to identify States party to the PCT on the front pages of pamphlets publishing international applications under the PCT.

AL	Albania	ES	Spain	LS	Lesotho	SI	Slovenia
AM	Armenia	FI	Finland	LT	Lithuania	SK	Slovakia
AT	Austria	FR	France	LU	Luxembourg	SN	Senegal
AU	Australia	GA	Gabon	LV	Latvia	SZ	Swaziland
AZ	Azerbaijan	GB	United Kingdom	MC	Monaco	TD	Chad
BA	Bosnia and Herzegovina	GE	Georgia	MD	Republic of Moldova	TG	Togo
BB	Barbados	GH	Ghana	MG	Madagascar	TJ	Tajikistan
BE	Belgium	GN	Guinea	MK	The former Yugoslav Republic of Macedonia	TM	Turkmenistan
BF	Burkina Faso	GR	Greece	ML	Mali	TR	Turkey
BG	Bulgaria	HU	Hungary	MN	Mongolia	TT	Trinidad and Tobago
BJ	Benin	IE	Ireland	MR	Mauritania	UA	Ukraine
BR	Brazil	IL	Israel	MW	Malawi	UG	Uganda
BY	Belarus	IS	Iceland	MX	Mexico	US	United States of America
CA	Canada	IT	Italy	NE	Niger	UZ	Uzbekistan
CF	Central African Republic	JP	Japan	NL	Netherlands	VN	Viet Nam
CG	Congo	KE	Kenya	NO	Norway	YU	Yugoslavia
CH	Switzerland	KG	Kyrgyzstan	NZ	New Zealand	ZW	Zimbabwe
CI	Côte d'Ivoire	KP	Democratic People's Republic of Korea	PL	Poland		
CM	Cameroon	KR	Republic of Korea	PT	Portugal		
CN	China	KZ	Kazakstan	RO	Romania		
CU	Cuba	LC	Saint Lucia	RU	Russian Federation		
CZ	Czech Republic	LI	Liechtenstein	SD	Sudan		
DE	Germany	LK	Sri Lanka	SE	Sweden		
DK	Denmark	LR	Liberia	SG	Singapore		
EE	Estonia						

COMMUNICATIONS NETWORK

BACKGROUND TO THE INVENTION

The present invention relates to a communications system, and in particular to a heterogeneous system employing a number of different call control mechanisms and different address types.

In a conventional, homogeneous, communications network, such as the public switched telephony network (PSTN), customers have only one type of address (in this case their telephone number) and there is a single uniform call control mechanism which is built into the network. The call control mechanism is used for establishing and for terminating calls and for recognising, e.g., when a called party is busy. Increasingly, however, customers have access to a range of different network technologies, each with its own address type. For example, a customer might have in addition to a telephone number a conventional IP (Internet protocol) address, a multicast IP address and a URL (uniform resource locator). In general, each of these different address types has associated with it a respective call control protocol (where the term "call control" is used broadly to denote the means for establishing and terminating connections between different parties. For example, audio or visual communication between parties using conventional IP addresses commonly uses the H.323 protocol, whereas for communication between broadband ATM addresses a different protocol, B-ISDN (broadband-integrated services digital network), is used. In practice, the call control protocol which is used for a particular communication session tends to be determined by the party who initiates the session. If other parties later join a session, they are then restricted to using the addressing and call control capabilities determined by the initiating party.

SUMMARY OF THE INVENTION

According to a first aspect of the present invention there is provided a method of operating a communications systems comprising:

- (a) exchanging between communication terminals call control capability data, which call control capability data identifies for each respective terminal a selected one or more of a plurality of different call control protocols and different network addresses and;

(b) setting up a call between the said communications terminals using call control protocols or network addresses identified in the said call control capability data.

The present invention makes it possible to use fully the capabilities of
5 terminals in a heterogeneous communications system by providing for peer terminals to exchange data which identifies their call control and address types. This approach allows the full potential of a heterogeneous communications system to be realised, since the use of this mechanism makes it unnecessary for users to adopt the "lowest common denominator" in addressing and call control types.
10 This serves to encourage the use of advanced call control and addressing mechanisms offering greater flexibility, even if initially those advanced call control and addressing mechanisms are used only by a minority of terminals in the communications system.

Preferably the step of exchanging call control capability data is carried out
15 prior to initiating call set-up.

The exchange of data might be integrated with the call set-up process, forming the initial part of that process. However, for maximum flexibility, it is preferred that the exchange is carried out independently prior to call set-up. The user might then choose not to proceed with set-up depending upon the capabilities
20 of the or each other terminal.

Preferably a first terminal initiates the exchange of call control capability data by transmitting the call control capability data for the first terminal to a second terminal and the second terminal returns an acknowledgement to the request, which acknowledgement includes call control capability data for the
25 second terminal.

It is found to be particularly effective to implement the exchange of data interactively, using a simple request/response.

Preferably the method includes monitoring continuously at a communications terminal a communications port and carrying out the exchange of
30 call control capability data whenever a request is received at the said port. Preferably the said step of monitoring continues after a call has been set up.

The preferred implementation further enhances the flexibility of the communications system, by allowing the exchange of capability data to be carried out at any time. This makes it possible for the system to respond, for example, to

the arrival of a new member with new communication capabilities in a multi-party communications session, or to respond to a change in the capabilities of one of the parties in an on-going session.

According to a second aspect of the present invention, there is provided a
5 communications terminal including:

(a) means for exchanging call control capability data with other communications terminals, which call control capability data identifies for respective terminal a selected one or more of a plurality of different call control protocols and different network addresses; and

10 (b) means for setting up a call between the said communications terminal and the other communications terminal using a call control protocol or network address type identified in the call control capability data received from the said other communications terminal.

The invention also encompasses a communications system including
15 communications terminal in accordance with the second aspect of the invention.

Methods and systems embodying the present invention will now be described in further detail, by way of example only, with reference to the accompanying drawings, in which:

Figures 1 is a schematic of a first network embodying the present
20 invention;

Figure 2 illustrates the exchange of capability data;

Figures 3a and 3b illustrate protocol stacks for systems embodying the invention;

Figures 4a and 4b show message flow sequences in systems embodying
25 the invention;

Figures 5 and 6 are diagrams showing software objects implementing the invention;

Figure 8 is a second embodiment; and

Figure 9 shows message flows in the networks of Figure 8.

30 A communications system 1 includes user terminals 2, 3 connected to different respective network domains 4, 5. In this example, the user terminals 2, 3 are computer workstations. The network domains in this example are broadband networks which support both ATM (asynchronous transfer modes) and IP (Internet protocol) transmission protocols. The user terminal has both a user address

(111.111.1.113) and an ATM address (ATM1). Similarly, the second user terminal has an Internet address (123.123.1.124) and an ATM address (ATM2). The network domains are linked by a connection 6 which also supports both of these protocols. Each of the terminals 2, 3 stores a respective client capability object
5 which records the address types and call control types which the terminal is capable of handling. The client objects in the different terminals communicate with each other using a predetermined communication protocol (in the present example Internet protocol). The exchange of address and call control capabilities between two clients is carried out independently of the call or calls in progress
10 between a session.

As illustrated in Figure 2, the exchange mechanism is initiated when a TRANSFER.request primitive is issued by the user of the outgoing client. The TRANSFER.request from the initiating client includes the client capabilities set for the corresponding terminal. This client capability set indicates all the call control
15 technologies and addresses supported by the terminal. The user of the incoming client is notified of the request for the exchange of client capability data by a TRANSFER.indication primitive. The user of the incoming client then initiates transfer of its capabilities using the TRANSFER.response primitive. The capabilities of the incoming terminal, that is the terminal which receives the incoming client
20 capability exchange request, are sent back to the originating terminal using a client capability set acknowledge message. The user of the originating client is notified that the exchange of capability data has taken place by a TRANSFER.confirm primitive.

The client capability set data in the message as described above identify
25 which of a number of predetermined address types and call control types are supported. Examples of different address types which might be supported include e-mail, URL (uniform resource locator), IP multicase, IP unicast, E.164, AESA. Examples of different call control types include H.225.0, SDP, B-ISDN Q.2971, B-ISDN ATM-F UNI, N-ISDN Q.931, PSTN BTNR 315.

30 Table 1 below contains a complete listing of the address and call control types supported by one implementation of the invention. As indicated in the table, different integer codes are used to identify the different respective call control and address types.

TABLE 1

Class	Data
Client	familiarName : String distinguishedName : String domainName : String password : String clientCapabilities : List
ClientCapability	
Address	addressType : Integer = 0
IP	addressType : Integer = 1 version : String
Multicast	addressType : Integer = 2 version : String timeToLive : Integer
Unicast	addressType : Integer = 3 version : String
E164	addressType : Integer = 4 version : String
AESA	addressType : Integer = 5 version : String type : String
E-mail	AddressType : Integer = 7
URL	AddressType : Integer = 7 SummaryText : String
CallControl	callControlType : Integer = 0 version : String
H225	callControlType : Integer = 1 version : String
SDP	callControlType : Integer = 2 version : String
BISDN	callControlType : Integer = 3 version : String
ATM-FUNI3.1	callControlType : Integer = 4

	version : String
Q2931	callControlType : Integer = 5 version : String
Q2971	callControlType : Integer = 6 version : String
NISDN	callControlType : Integer = 7 version : String
Q931	callControlType : Integer = 8 version : String
PSTN	callControlType : Integer = 9 version : String
BTNR315	callControlType : Integer = 10 version : String
SMTTP	callControlType : Integer = 11
HTTP	callControlType : Integer = 12

As indicated in the above table, the capabilities notified through the capability exchange mechanism may include a URL (uniform resource locator). The URL may be accessed by the terminal which initiated the capability set transfer in order to read details of further capabilities beyond those provided for in the table above. In this way the capability exchange protocol is made extensible to encompass new call protocols. The URL may also direct the terminal to resources, such as a Java applet, which may be downloaded by the terminal to facilitate its communication with the terminal which provided the URL. For example, the URL might relate to an HTTP page which includes a Java applet which displays a "call me" button. Then when the button is clicked on, a call is made from the terminal owning the URL to the other terminal.

Figures 3a and 3b illustrate the software architecture of a system embodying the invention. Each communications terminal runs a communications programme comprising a communications graphics user interface (GUI 31) on top of a communications application 32. The communications application 32 is supported by a number of resources 33 including a capability exchange module (CE) below this, a "listener module" continually monitors a predetermined socket

defined by the IP address of the communications terminal together with a 16-bit port number. The CE and listener modules may coexist with other resources such as the session invitation protocol (SIP) and H323 modules shown in Figure 3a. Capability set messages are passed between the UDP/TCP/IP layer and a capability exchange (CE) module. The listener module communicates transfer primitives to/from the CE module. In this preferred implementation, UDP (unreliable datagram protocol) is used rather than TCP (transport control protocol) for transporting the capability set data across the network. This avoids the overheads involved in setting up a TCP data stream. However this approach then requires that packets should be re-transmitted if not acknowledged after a predetermined period, to allow for the possibility of packet loss. Figure 3b shows message flows across different API's (application programmer's interfaces) as capability data is exchanged between two terminals. The transfer primitives shown in Figure 2 correspond to the API between the application layer (implemented using the Java language in this example) and the lower layers of the protocol stack.

Figures 4a and 4b show in further detail the sequence of message flows between terminals A and B in different implementations of the invention. In the sequence of Figure 4a, the exchange of capability data takes place prior to a session being established. Immediately after the exchange of capability data, a call is set-up using, e.g., the sequence of messages defined for an ISDN protocol such as H.320, in the case where the capability data indicated that both parties had this call control capability. In the second example, illustrated in Figure 4b, following the exchange of capability data, and prior to a call being set-up using, e.g., the H.323 call control protocol, Session Invitation Protocol (SIP) to establish the session.

Figures 5 and 6 are diagrams using the Rational ROSE (Rational Object-oriented Software Engineering) formalism to define software objects for implementing the embodiments discussed above. The structure shown may be compiled using the ROSE software tool which is available commercially from Rational Software Corp. of Santa Clara, California to generate, e.g., C++ code to form the basis of an implementation of the invention. As shown in Figure 6, a client object which is instantiated on each terminal includes `clientcapabilityset` and `clientcapabilityreturn` methods, which methods are inherited by a client capability

object. The properties of the client capability object are in turn inherited by address and call control objects as shown in Figure 5.

As an alternative to the direct transfer of client capability data, this may be effected via a directory. This method is described in the co-pending European application 97309810.6 filed 4 December 1997 (agent's reference A25527) the contents of which are incorporated herein by reference. Figure 7 illustrates an embodiment in which the exchange of data is mediated by a directory platform 7. The directory platform 7 is connected to the network by a link 8 which transports IP data between the network and the directory platform 7. The other components of the network are as previously described with respect to Figure 1.

In use, customers at user terminals 2,3 both register with a directory server which, in this example, runs on the directory platform 7. Subsequently, as will be further described below, when a customer at user terminal 2 wishes to contact the customer registered at user terminal 3, then a request is submitted to the directory server. This request is transmitted to the IP address of the directory platform 7. The request includes data, such as the customer name, which identifies the called customer. The directory server uses this data to select a corresponding user profile which was created when the customer registered with the directory server. From the selected user profile the directory server returns to the calling customer the network addresses and call control capabilities of the called customer. Using this information the calling customer sets up a call to the other customer. For example, the calling customer in this instance may choose to establish a connection to the ATM address (ATM2) using the ATM call control protocol (Q.2931).

Figure 8 shows the message flows between a local client, the directory platform (or "server") 7 and a remote client in this embodiment, as the local client registers its call control capability with the directory, and the remote client subsequently reads the call control capability data.

CLAIMS

1. A method of operating a communications systems comprising:
 - (a) exchanging between communication terminals call control capability
5 data, which call control capability data identifies for each respective terminal a
selected one or more of a plurality of different call control protocols and different
network addresses and;
 - (b) setting up a call between the said communications terminals using
call control protocols or network addresses identified in the said call control
10 capability data.
2. A method according to claim 1, in which the step of exchanging call control
capability data is carried out prior to initiating call set-up.
- 15 3. A method according to claim 1 or 2, in which a first terminal initiates the
exchange of call control capability data by transmitting the call control capability
data for the first terminal to a second terminal and the second terminal returns an
acknowledgement to the request, which acknowledgement includes call control
capability data for the second terminal.
20
4. A method according to any one of the preceding claims, including monitoring
continuously at a communications terminal a communications port and carrying out
the exchange of call control capability data whenever a request is received at the
said port.
25
5. A method according to claim 4, in which the monitoring of the communications
port continues after a call has been set up.
6. A method according to any one of the preceding claims, including
30 communicating as part of the said call control capability data a pointer to a source
of further data identifying capabilities not provided for directly in the call control
capability exchange protocol.

7. A method according to claim 6, in which the pointer is a uniform resource locator (URL).

8. A communications terminal including:

5 (a) means for exchanging call control capability data with other communications terminals, which call control capability data identifies for a respective terminal a selected one or more of a plurality of different call control protocols and different network addresses; and

(b) means for setting up a call between the said communications
10 terminal and the other communications terminal using a call control protocol or network address type identified in the call control capability data received from the said other communications terminal.

9. A communications network including a communication terminal according to
15 claim 8.

10. A communications network comprising a plurality of communication terminals, in which different ones of the plurality of communications terminals support different respective call control protocols, and in which each of the
20 communications terminals includes:

(a) means for exchanging call control capability data with other communications terminals, which call control capability data identifies for a respective terminal a selected one or more of the plurality of different call control protocols and different network addresses; and

25 (b) means for setting up a call between the said communications terminal and the other communications terminal using a call control protocol or network address type identified in the call control capability data received from the said other communications terminal.

Fig. 1.

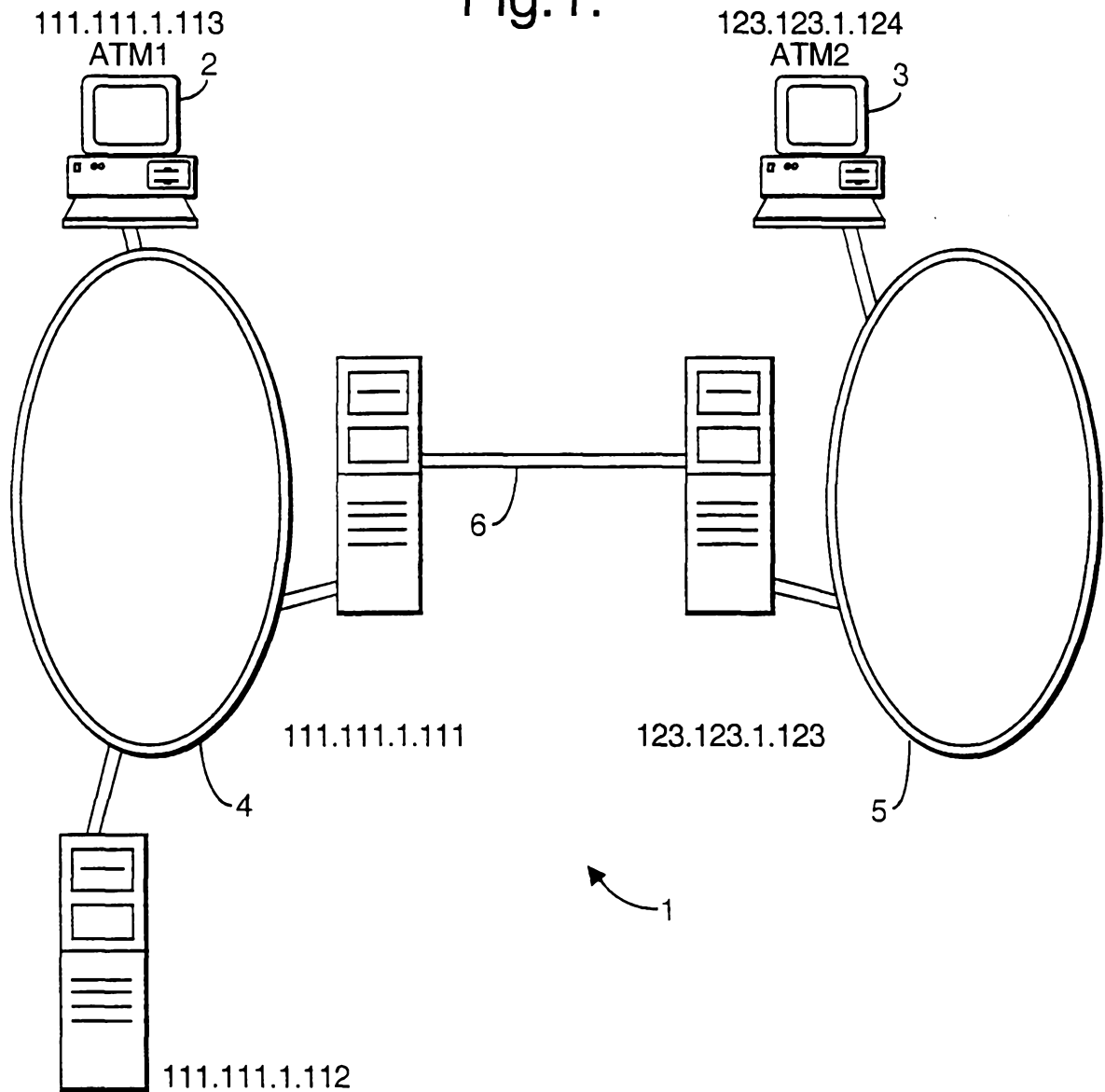

Fig. 2.

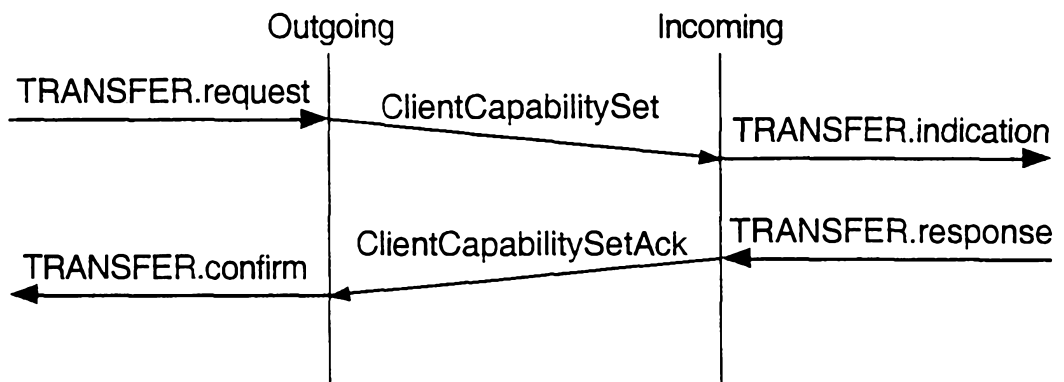

Fig.3a.

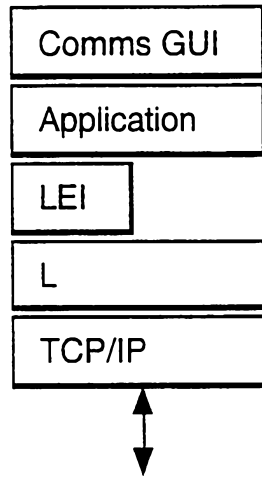
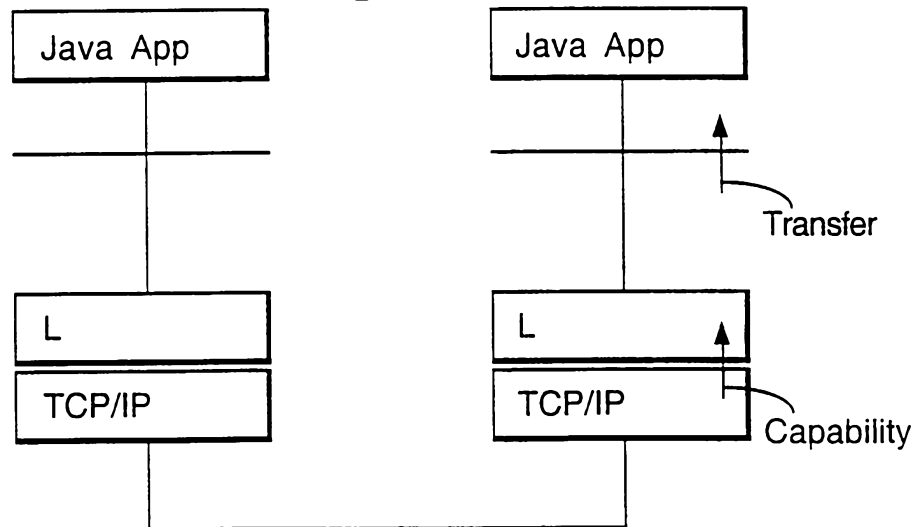

Fig.3b.



3/10

Fig.4a.

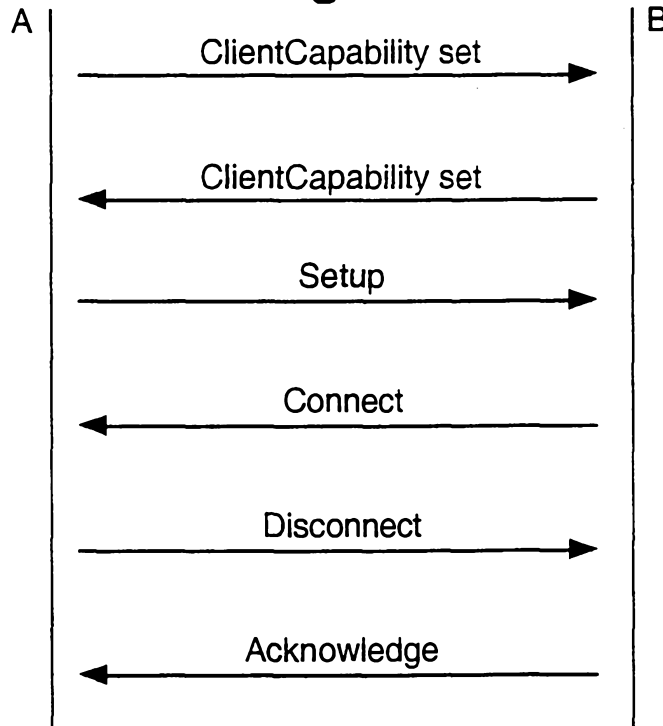

Fig.4b.

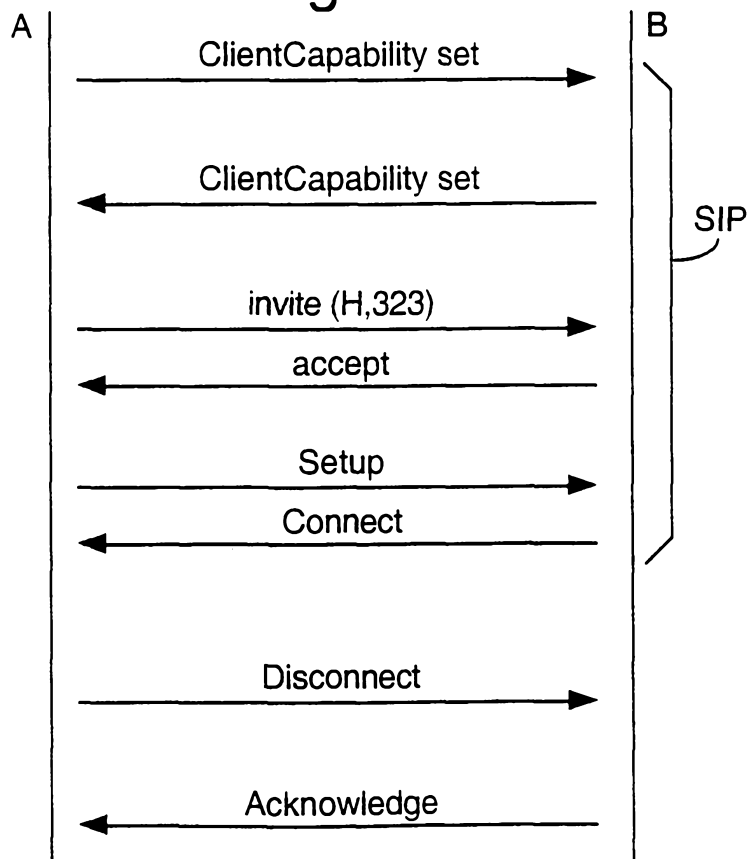

Fig.5.

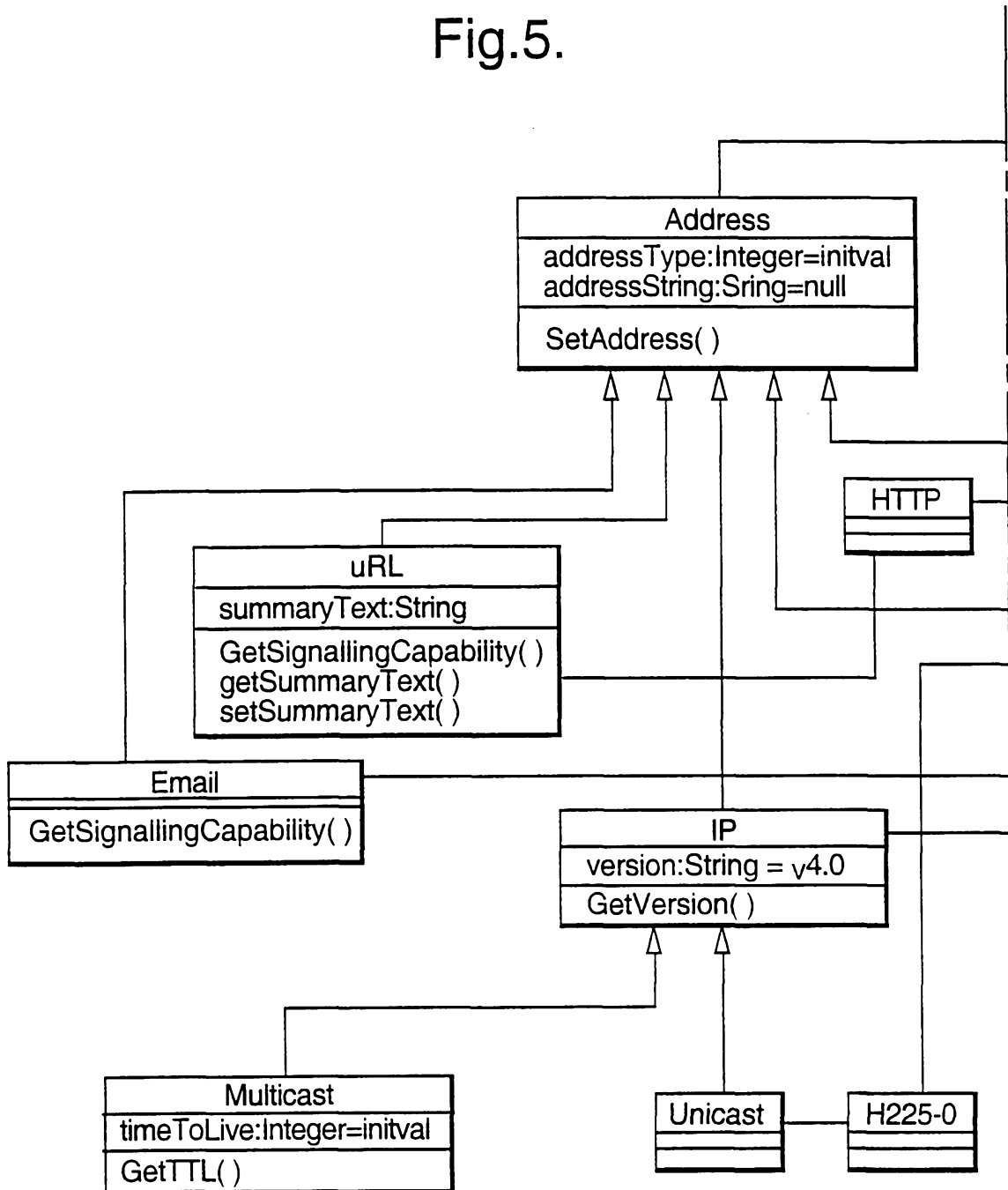

Fig.5 (Cont i).

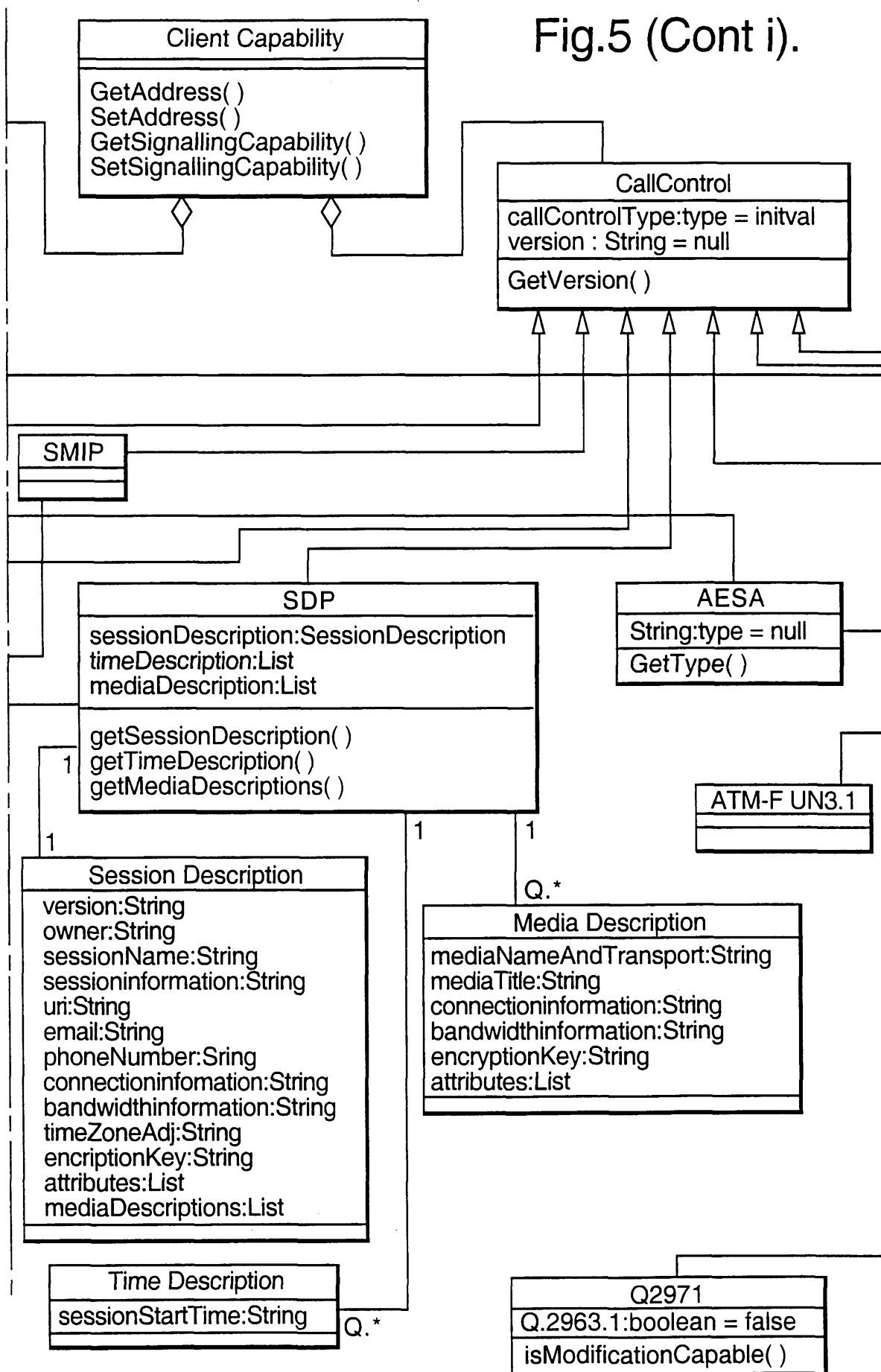

Fig.5 (Cont ii).

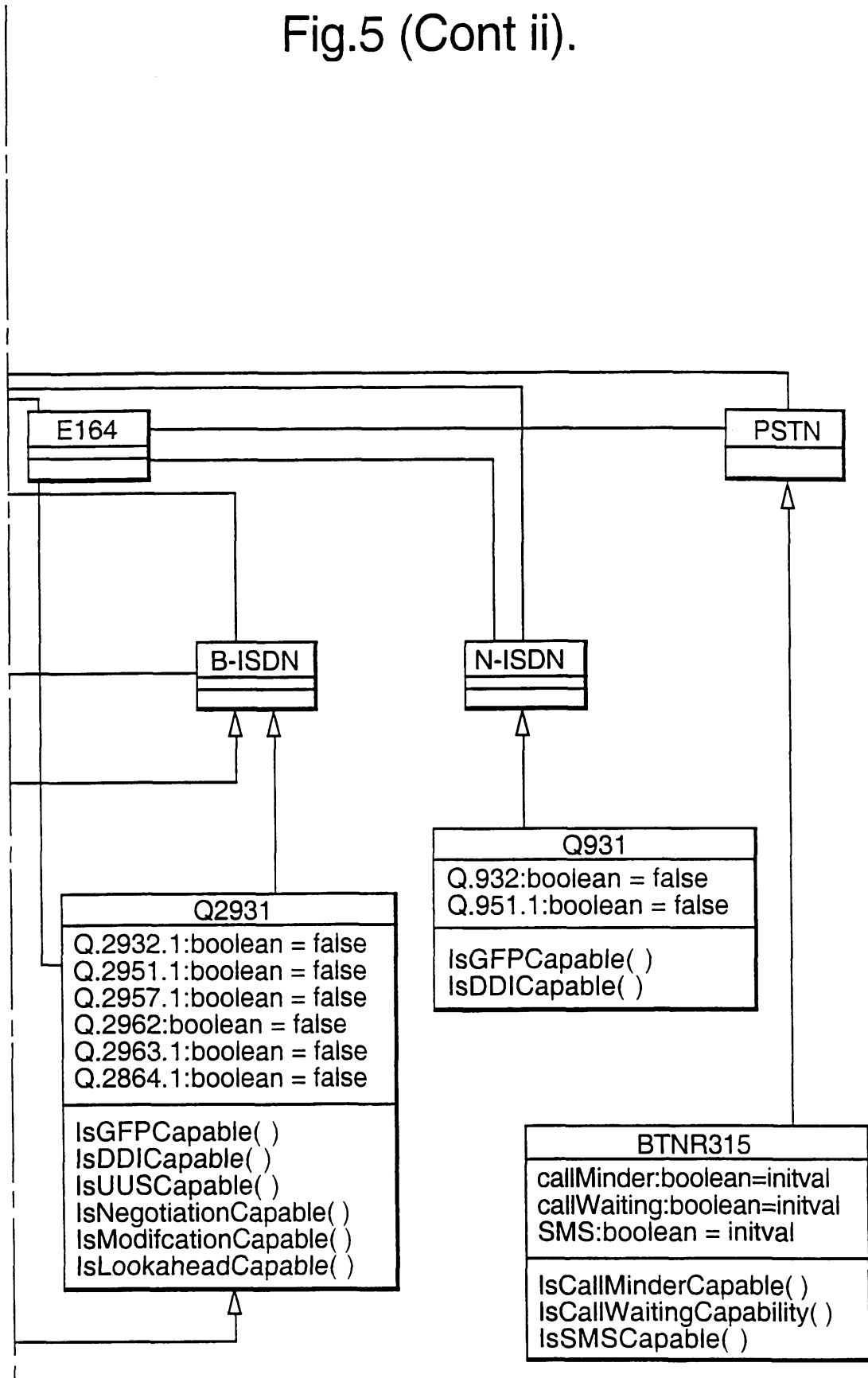

Fig.6.

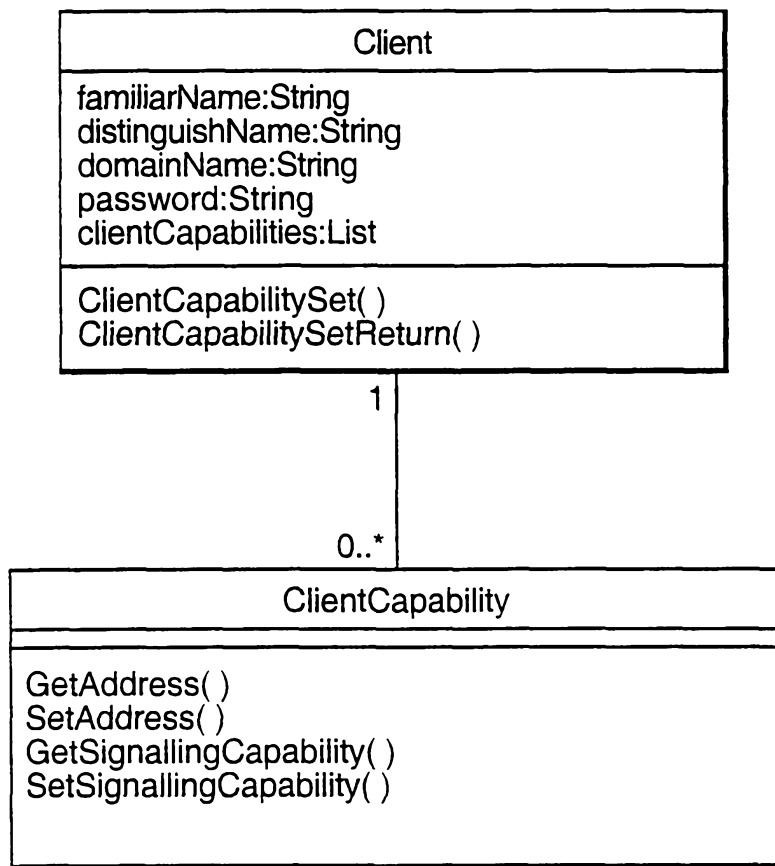

Fig.7.

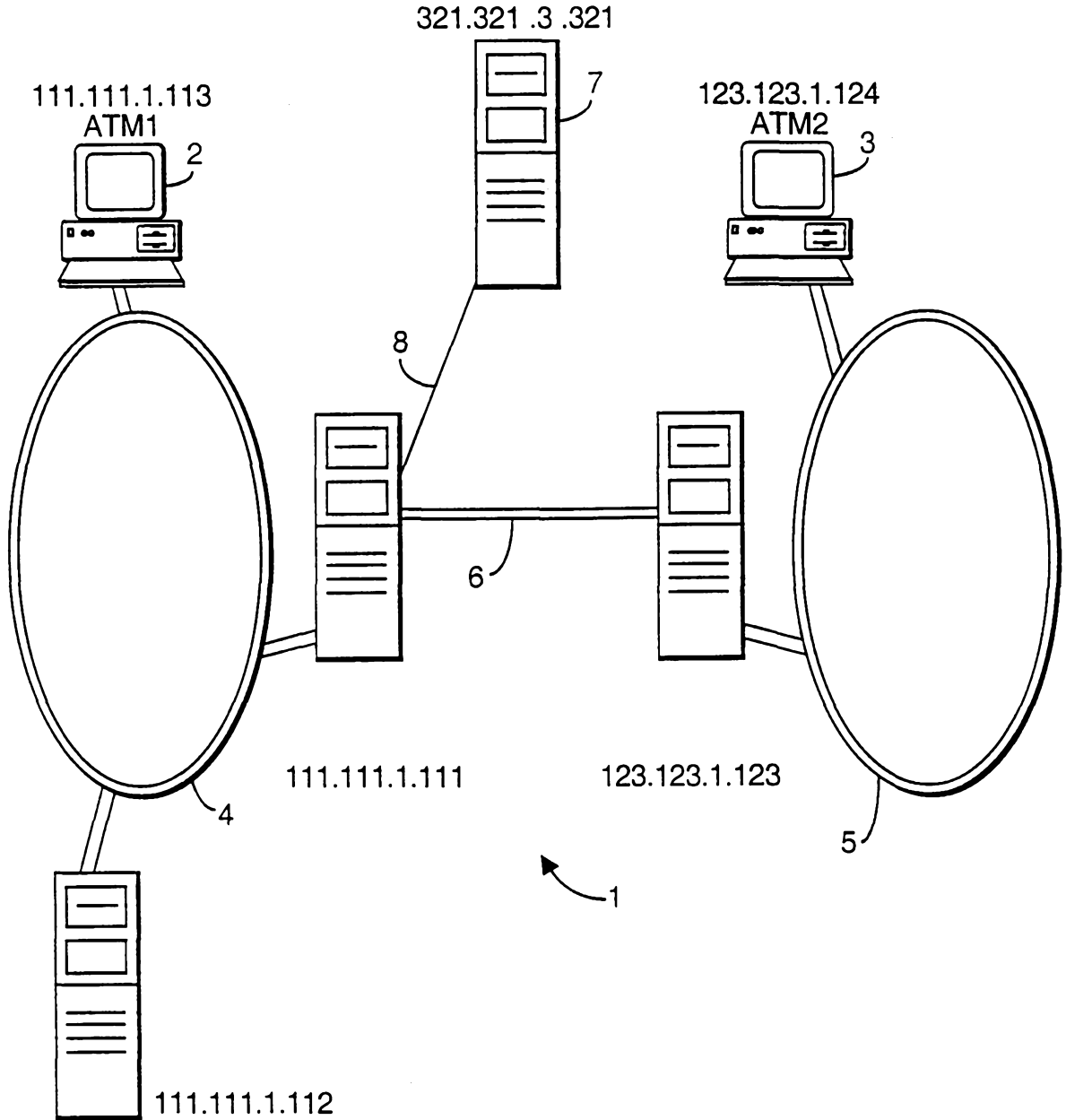

Fig.8.



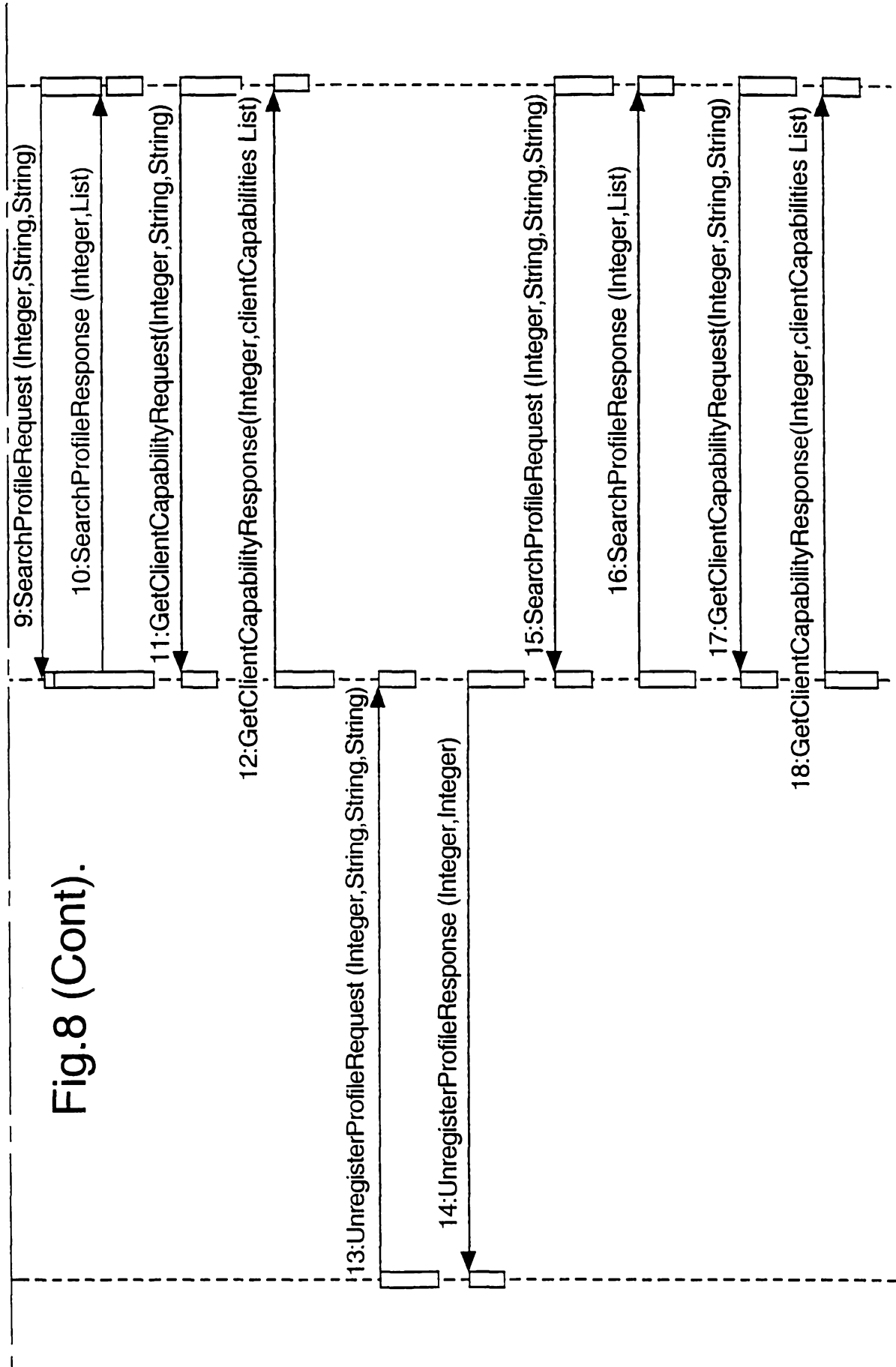

Fig.8 (Cont).