

Nov. 13, 1945.

N. R. SCHWARTZ

2,389,089

COMBINATION WORK LAMP AND BULB GUARD

Filed Jan. 10, 1944

2 Sheets-Sheet 1

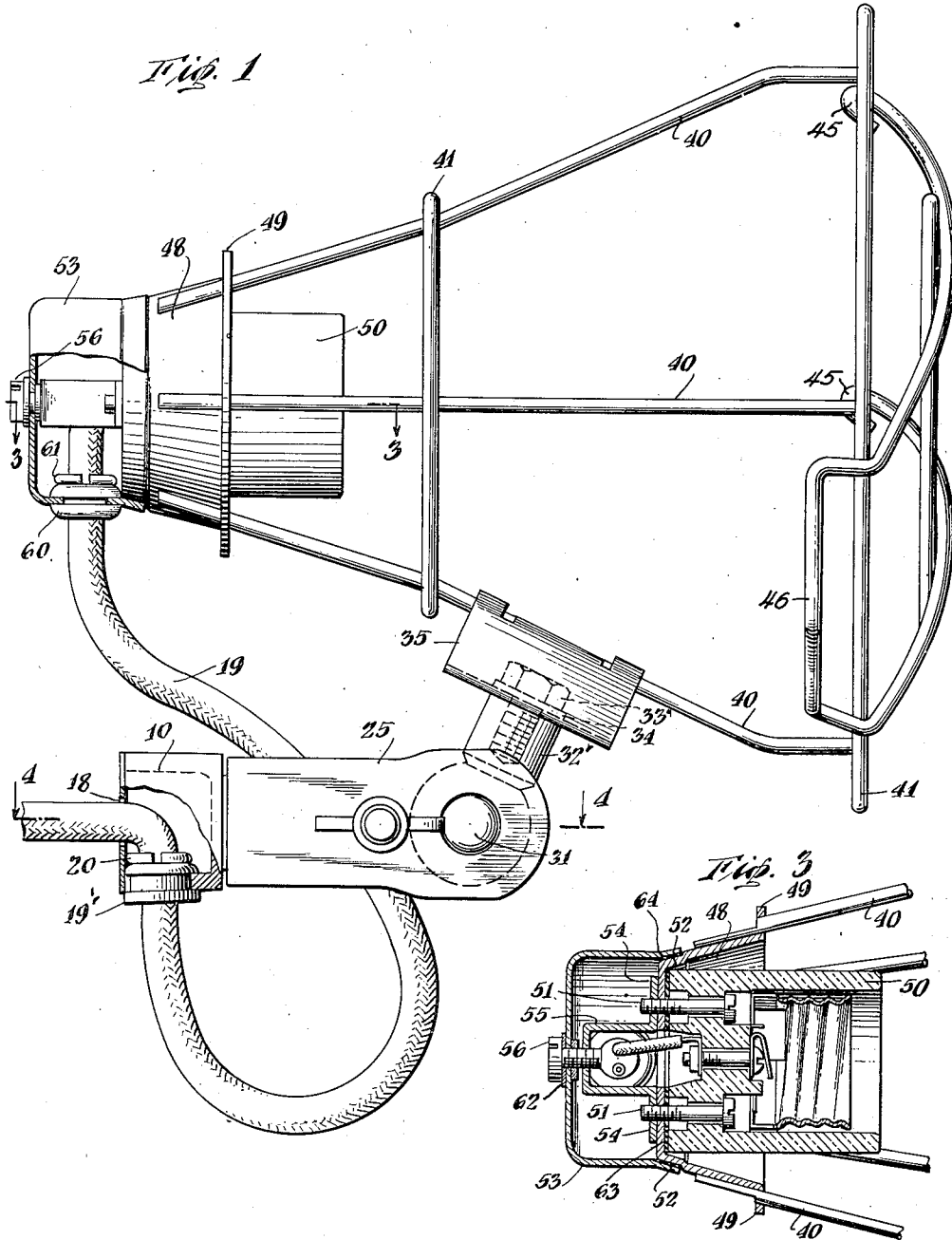

INVENTOR.

Nathan Rodney Schwartz

BY

Erwin Schmeckel

ATTORNEY

Nov. 13, 1945.

N. R. SCHWARTZ

2,389,089

COMBINATION WORK LAMP AND BULB GUARD

Filed Jan. 10, 1944

2 Sheets-Sheet 2

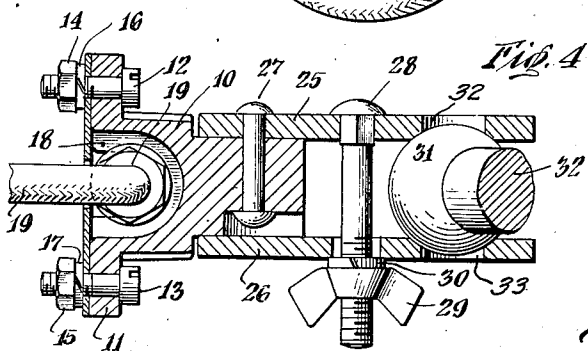
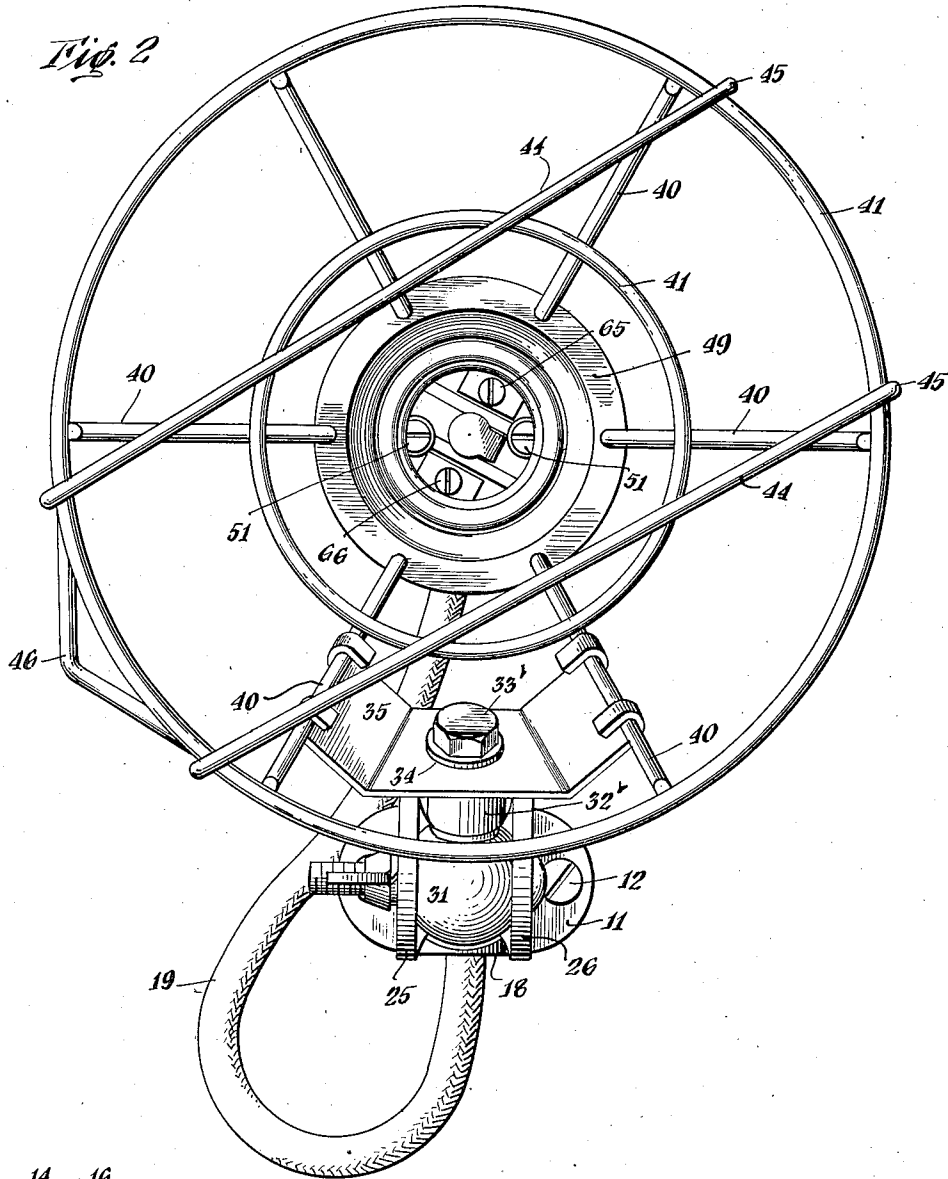

INVENTOR.
Nathan Rodney Schwartz
BY
Erin Schaefer
ATTORNEY

UNITED STATES PATENT OFFICE

2,389,089

COMBINATION WORK LAMP AND BULB GUARD

Nathan Rodney Schwartz, New York, N. Y.

Application January 10, 1944, Serial No. 517,747

3 Claims. (Cl. 240—54)

This invention relates to work lamps such as are commonly attached to work benches, machines, precision instruments and the like, and more particularly to a combination work lamp and bulb guard, the latter being provided with a swivel mounting, whereby the lamp guard and bulb may be rotated axially with respect to the lamp base, and whereby the lamp guard and bulb may also be turned angularly with respect to the base, so as to cast light to any desired point.

A further advantage of the present invention lies in the provision of a combined work lamp and bulb guard having a swivel mounting, the latter being provided with means for automatic adjustment at any desired angle or any desired rotative position.

Yet another purpose of the present invention resides in the provision of a combination work lamp and bulb guard which is completely waterproof through the provision of gaskets at strategic points within the structure.

And another aim of the present invention lies in the provision of a combination work lamp and bulb guard, consisting broadly of three parts, the base, the swivel member and the bulb guard and socket, each of the parts being so mounted and so constructed that, when repairs or adjustments are required, each part can be removed for that purpose without necessitating the complete disassembly of the device.

A further advantage of this invention resides in the provision of means for wiring or re-wiring the socket from the rear of the bulb guard instead of the front as is now generally done, thus saving considerable time.

A still further feature of this invention lies in the provision of a combination work lamp and bulb guard of rigid construction, and in the provision of strain relief at strategic points for the protection of the cable.

These and other meritorious objects and advantages are achieved by the construction and combination of parts, hereinafter described and illustrated in the accompanying drawings, forming a material component of the present disclosure, and in which:

Figure 1 is a side elevational view of a combination work lamp and bulb guard, constructed in accordance with the present invention.

Figure 2 is a front elevational view of the lamp and guard.

Figure 3 is a sectional view of the device, the section being taken on line 3—3 of Figure 1; and

Figure 4 is a sectional view of the device, the section being taken on line 4—4 of Figure 1.

Referring in greater detail to the drawings, the numeral 10 designates in general the base or standard of the lamp, the base being cylindrical in cross-section and of hollow interior and provided with a foot member 11, arranged rectangularly with respect to the standard, and being provided with two openings for the passage of screws or other fastening means therethrough, one of which is indicated at 12 in Figure 2, whereby the lamp may be removably secured to a work bench or other desirable surface. Figure 4 illustrates both screws, 12 and 13, each of which being provided with a nut, 14 and 15 respectively, for the conventional purpose. Washers 16 and 17 may be inserted between nuts 14 and 15 and the underside of the foot member 11. Near foot member 11, standard 10 is provided with a circular opening 18 for the passage of the electric cable 19 therethrough, opening 18 having a grommet 19' for the protection of the cable and not to ground the lamp. For the further protection of cable 19, strain relief 20 may be inserted as illustrated in the drawings.

At its upper end, standard 10 has secured thereto a pair of arms 25—26, the arm 25 being secured to standard 10 by rivet 27. Plates or arms 25—26, near their middle, are held together by screw 28 having a wing nut 29 for ease in removal, and a washer 30 may be provided between the wing nut 29 and the outer face of arm 26 as is illustrated in the drawings. A ball 31 seats between arms 25 and 26, arms 25—26 at that point being each provided with a circular opening 32 and 33 respectively, to form a firm seat for ball 31. Integral with ball 31 and extending upwardly beyond the length of said arms is a shank 32' of cylindrical cross-section and having a vertical bore through its center, through which may pass screw 33' provided with washer 34 as illustrated in the drawings. By means of screw 33' or in any other desirable manner, shank 32' and the other members heretofore described, are secured to a bracket 35 for a purpose to be presently described.

The present invention further provides an electric lamp bulb guard which consists of a plurality of longitudinal wires 40, and a pair of circular wires 41, the outermost of which is of greater diameter than the rear one, the entire structure forming a cage within which an incandescent lamp bulb may be retained. To gain access to the interior of the cage, there is provided a door formed out of a single strand of wire 44, said wire 44 being twisted to form two parallel sides which extend over the outermost of the circular wires

41, wire 44 having both of its ends bent upon wire 41 to form a hinge, as at 45, the front of wire 44 being twisted to form a gripping element 46. The several vertical wires and circular wires of this cage are secured to each other by soldering or in any other suitable manner, and the junction may be flattened to prevent disengagement thereof. At their lower ends, longitudinal wires 40 are secured to a cup-shaped member 48, the upper edge of the cup-shaped member being turned rectangularly to form a lip 49 which is provided with a plurality of holes, one for each of said wires 40, the latter being entered through said holes and then secured by spot welding or otherwise to said cup-shaped member, as is shown in Figures 1 and 3 of the drawings. To make the junction secure, the ends of wires 40 may be flattened thus preventing their disengagement from the cup-shaped member.

Cup-shaped member 48 serves as seat for socket 50, which may be secured to the cup-shaped member by means of screws 51 passing through corresponding screw openings in said cup-shaped member. At its bottom edge, member 48 is slightly constricted, as at 52, to receive and retain the edge of cap 53. Cap 53 is provided with a central vertical screw opening, and screws 51, after passing through appropriate openings in member 48, also pass through the outstretched arms 54 of yoke 55 having an opening at its top for the passage of screw 56 by which cap 53 is secured to cup-shaped member 48. Cap 53 is provided with an opening in its side for the passage of cable 19 therethrough, and grommet 60 and strain relief 61 may be provided as shown in Figure 1. Gaskets may be provided as shown at 62, 63 and 64 to render the device waterproof.

Socket 50 is provided with conventional terminals 65 and 66. Bracket 35 is secured to the lamp guard by turning the lateral edges of said bracket about a pair of longitudinal wires 40 as is shown in Figure 2 of the drawings.

There has been described and shown a simple yet highly efficient combination work lamp and bulb guard, the operation of which is believed to be apparent from the disclosure. If any repairs are to be made, it is not necessary to take the entire device apart. The guard and socket, for instance may be severed from the rest of the device by removing screw 33'; ball 31 may be removed by the obvious use of wing nut 29; and cap 53 may be removed by disengaging screw 56, the latter will be done when it is desired to re-wire the lamp.

There has thus been shown and described a combination work lamp and bulb guard in the preferred form of its construction, but it is to be understood that the foregoing is to be regarded merely as descriptive and illustrative of the best known embodiment, and not as restrictive or limitative to the exact details shown. Applicant reserves the right to make such minor changes in the construction of the device as may come within the scope of the appended claims, without thereby departing from the spirit of this invention.

Having thus described the invention, what is claimed as new and desired to secure by Letters Patent is:

1. The combination of a work lamp and a bulb guard comprising a base, a foot member at one end thereof, a pair of spaced apart arms at the other end of said base, means passing through said arms increasing or decreasing their relative distance, a swivel member between said arms, a

shank integral therewith, said shank extending upwardly beyond said arms, a central vertical opening through said shank, a bracket, said bracket having two ends and a curved central portion, a vertical opening through said curved portion in the center thereof, means passing through said two openings removably engaging said bracket and said shank, a bulb guard comprising a plurality of longitudinal wires, said wires spaced apart, two rings, said rings embracing said longitudinal wires, one of said rings of larger diameter than the other of said rings, the larger of said rings embracing the front ends of said longitudinal wires, the smaller of said rings embracing said longitudinal wires substantially midway their length, a door for said lamp guard, said door comprising a unitary strand of wire twisted to form two parallel sides and a front portion, the ends of said parallel sides bent about the larger of said two rings forming a hinge, the central portion of said strand twisted to form a finger grip, a cup-shaped member, the ends of said longitudinal wires secured thereto, a socket seated in said cup-shaped member, and a closure means for said cup-shaped member.

2. In a combination work lamp and bulb guard, a base, a foot member at one end of said base, openings in said foot member, a pair of spaced apart parallel arms, an opening near the lower end of one of said arms, a corresponding opening in said base, means passing through said two openings securing said arm to said base, a circular opening through said arm substantially midway their length, manually operable means adjusting the relative distance between said arms, a ball between said arms near the upper ends thereof, a cylindrical shank integral with said ball, said shank extending upwardly beyond said arms, a central vertical opening through said shank, a bracket, said bracket having two ends and a curved central portion, a circular opening through said curved central portion midway thereof, means passing through said opening in said bracket and said shank removably engaging said bracket and said shank, a bulb guard comprising a cage having a plurality of spaced apart longitudinal wires, two rings embracing said wires, one of said rings of larger diameter than the other of said rings, said larger ring secured to the front ends of said wires, said smaller ring secured to said wires substantially midway their length, closure means hingedly secured to the larger of said rings, a cup-shaped member, the free ends of said longitudinal wires secured to said cup-shaped member, the ends of said bracket twisted about two adjacent longitudinal wires, a socket in said cup-shaped member, an opening in the bottom of said cup-shaped member for the admission of electric wires to the socket, and a closure means for said opening.

3. The combination work lamp and bulb guard comprising a base, a foot member at one end thereof, a pair of spaced apart arms at the other end of said base, means passing through said arms adjusting the relative distance between said arms, a swivel member between said arms near the upper ends thereof, a shank integral with said swivel member, a central vertical opening through said shank, a bracket, said bracket having two ends, a curved body portion therebetween, a circular opening in the center thereof, means passing through said two openings detachably engaging said bracket and said shank, a bulb guard comprising a plurality of spaced apart

longitudinal wires, two wire rings, said rings embracing said longitudinal wires, one of said rings of larger diameter than the other of said rings, the larger of said rings secured to said longitudinal wires at the outer ends thereof, said smaller ring embracing said longitudinal wires substantially midway their length, a door formed from a unitary strand of wire hingedly secured to said larger ring, said unitary strand of wire twisted at its center forming a finger grip, the ends of said bracket bent about two adjacent longitudinal wires, a cup shaped member having a lip formed at its outer edge, a plurality of openings in said lip, one for each of said longitudinal wires,

said longitudinal wires passing through said openings and secured to said cup-shaped member, said cup-shaped member constricted near the base thereof, a socket in said cup-shaped member, two openings in said socket, a yoke having two outstretched arms, openings in said arms, securing means passing through said openings in said socket and said openings in said yoke, a central opening in said yoke, a closure cap, a central opening therein, and detachable retaining means passing through said opening in said cap and said opening in said yoke.

NATHAN RODNEY SCHWARTZ.