

(19) World Intellectual Property Organization  
International Bureau



(43) International Publication Date  
8 May 2003 (08.05.2003)

PCT

(10) International Publication Number  
WO 03/037208 A1

- (51) International Patent Classification<sup>7</sup>: **A61C 8/00**
- (21) International Application Number: PCT/SE02/01995
- (22) International Filing Date:  
1 November 2002 (01.11.2002)
- (25) Filing Language: English
- (26) Publication Language: English
- (30) Priority Data:  
09/985,129 1 November 2001 (01.11.2001) US
- (71) Applicant (for all designated States except US): **ASTRA  
TECH AB** [SE/SE]; Aminogatan 1, P. O. Box 14, S-431  
21 Mölndal (SE).
- (72) Inventors; and
- (75) Inventors/Applicants (for US only): **ENGSTRÖM, Kent**  
[SE/SE]; Ängelholmsgatan 6, S-214 22 Malmö (SE).  
**HALLDIN, Anders** [SE/SE]; Framnäsgratan 20 D, S-412  
62 Göteborg (SE).
- (74) Agent: **AWAPATENT AB**; Box 11394, S-404 28 Göte-  
borg (SE).

- (81) Designated States (*national*): AE, AG, AL, AM, AT (util-  
ity model), AT, AU, AZ, BA, BB, BG, BR, BY, BZ, CA,  
CH, CN, CO, CR, CU, CZ (utility model), CZ, DE (util-  
ity model), DE, DK (utility model), DK, DM, DZ, EC, EE  
(utility model), EE, ES, FI (utility model), FI, GB, GD, GE,  
GH, GM, HR, HU, ID, IL, IN, IS, JP, KE, KG, KP, KR, KZ,  
LC, LK, LR, LS, LT, LU, LV, MA, MD, MG, MK, MN,  
MW, MX, MZ, NO, NZ, OM, PH, PL, PT, RO, RU, SD,  
SE, SG, SI, SK (utility model), SK, SL, TJ, TM, TN, TR,  
TT, TZ, UA, UG, US, UZ, VC, VN, YU, ZA, ZM, ZW.
- (84) Designated States (*regional*): ARIPO patent (GH, GM,  
KE, LS, MW, MZ, SD, SL, SZ, TZ, UG, ZM, ZW),  
Eurasian patent (AM, AZ, BY, KG, KZ, MD, RU, TJ, TM),  
European patent (AT, BE, BG, CH, CY, CZ, DE, DK, EE,  
ES, FI, FR, GB, GR, IE, IT, LU, MC, NL, PT, SE, SK,  
TR), OAPI patent (BF, BJ, CF, CG, CI, CM, GA, GN, GQ,  
GW, ML, MR, NE, SN, TD, TG).

**Declarations under Rule 4.17:**

— as to applicant's entitlement to apply for and be granted a patent (Rule 4.17(ii)) for the following designations AE, AG, AL, AM, AT, AU, AZ, BA, BB, BG, BR, BY, BZ, CA, CH, CN, CO, CR, CU, CZ, DE, DK, DM, DZ, EC, EE, ES, FI, GB, GD, GE, GH, GM, HR, HU, ID, IL, IN, IS, JP, KE, KG,

[Continued on next page]

(54) Title: COMPONENTS FOR IMPROVED IMPRESSION MAKING

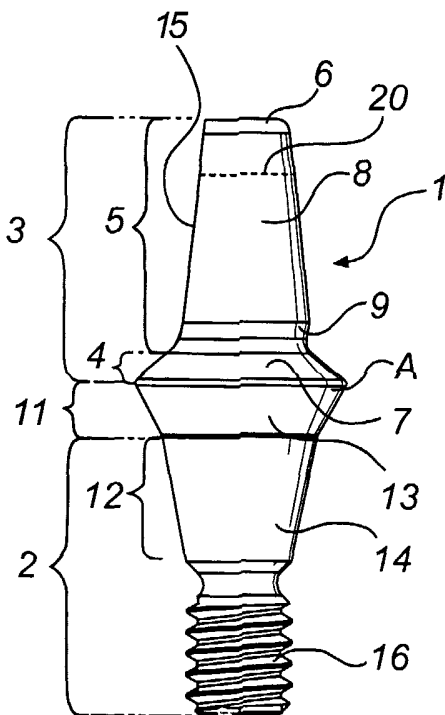

(57) Abstract: The invention relates to components for an improved system for pick-up impression making at a dental implantation site, comprising an abutment, an abutment replica and an impression coping. The invention also relates to a series of abutments and to a set comprising an abutment and an impression coping. The abutment is comprising an implant contacting region (2) and a component support region (3), said component support region (3) having a maximum diameter (A) and extending coronally of said maximum diameter to a coronal end (6), and being provided with a component engagement (9) being arranged for releasable engagement with said component by linear displacement of said dental component in relation to said abutment (1), said component engagement (9) being located at a position closer to said maximum diameter (A) than to said coronal end (6) of said component support region (3).

WO 03/037208 A1



KP, KR, KZ, LC, LK, LR, LS, LT, LU, LV, MA, MD, MG, MK, MN, MW, MX, MZ, NO, NZ, OM, PH, PL, PT, RO, RU, SD, SE, SG, SI, SK, SL, TJ, TM, TN, TR, TT, TZ, UA, UG, UZ, VC, VN, YU, ZA, ZM, ZW, ARIPO patent (GH, GM, KE, LS, MW, MZ, SD, SL, SZ, TZ, UG, ZM, ZW), Eurasian patent (AM, AZ, BY, KG, KZ, MD, RU, TJ, TM), European patent (AT, BE, BG, CH, CY, CZ, DE, DK, EE, ES, FI, FR, GB, GR, IE, IT, LU, MC, NL, PT, SE, SK, TR), OAPI patent (BF, BJ, CF, CG, CI, CM, GA, GN, GQ, GW, ML, MR, NE, SN, TD, TG)

— of inventorship (Rule 4.17(iv)) for US only

**Published:**

— with international search report

For two-letter codes and other abbreviations, refer to the "Guidance Notes on Codes and Abbreviations" appearing at the beginning of each regular issue of the PCT Gazette.

## COMPONENTS FOR IMPROVED IMPRESSION MAKING

### **Field of the Invention:**

The invention relates to components for an improved system for pick-up impression making at a dental implantation site, comprising an abutment, an abutment replica and an impression coping. The invention also relates to a series of abutments and to a set comprising an abutment and an impression coping.

### **Description of Related Art:**

Dental implant systems are widely used for replacing damaged or lost natural teeth. In such systems, an implant is placed in the jaw of a patient in order to replace the natural tooth root. An abutment structure comprising one or several parts may then be attached to the implant in order to build up a core for the part of the prosthetic tooth protruding from the bone tissue, through the soft gingival tissue and into the mouth of the patient. On said abutment, the prosthesis or crown may finally be seated.

The final prosthesis must be sized and configured so as to naturally fit with the remaining teeth of the patient, both for functionality and aesthetics. To this end, a dental technician needs to try out a proper prosthesis for the individual patient, using a model of the jaw of the patient, said model including the implant and possibly an abutment structure. To provide such a model, so called master cast modelling techniques are used.

One category of such modelling techniques is the so called "pick-up" method. A pick-up method could be described by the following subsequent steps:

- An impression cap is placed on the implant and/or the abutment.
- An impression material is applied to the jaw, such that said impression cap is embedded in the impression material.
- The impression material is removed from the jaw, bringing along the impression cap still being embedded in the impression material. The impression material now has the inverse form of the jaw with the impression cap at the site of the implant/abutment.

- A replica replicating the shape of the implant and/or abutment is inserted into the embedded impression cap, in the same manner as the original implant and/or abutment was connected to the impression cap.
- A moulding material is poured into the inverse form of the jaw made out of the impression material and around the replica and let to harden.
- The impression material is removed from the hardened moulding material, said moulding material now forming a true, or non-inverse model of the jaw with the replica replacing the original implant/abutment.

In the following, reference will be made to some prior art documents describing pick-up methods or components to be used therewith.

US 6 068 478 (Grande et al.) discloses an impression system including an impression cap for transferring an end, protruding from a human tissue structure, of an implant which is fitted in the human body, including possible superstructures, to a master cast. The outwardly directed implant end has an undercut contour on its outside, and the impression cap has a geometry which complements the undercut contour and engages therein. The undercut contour is formed either by an implant geometry tapering in a trumpet shape towards the implant bed, or by a recess near the implant end.

In said US 6 068 478 (Grande et al.), a superstructure part is described to be screwed into the implant such that an abutment of the superstructure is projecting above the implant shoulder. For taking an impression of the mouth situation to a finished master cast, a slide sleeve is first of all pushed onto the conical superstructure. Then, an impression cap is pushed over the slide sleeve. At the very bottom, the impression cap has a cap shoulder which is complementary to the implant shoulder. On the outside, the cap shoulder is surrounded by an elastic snap element directed inwards, so that it can snap over the implant shoulder and releasably grip an undercut contour on the implant head. An impression tray filled with impression compound is now pressed onto the implantation site. After withdrawing the impression tray, the impression cap and the slide sleeve remain embedded in the impression compound, and the impression is obtained. An analogous manipulation implant having a shape corresponding to the conical superstructure is now pushed into the slide sleeve. Finally, a manipulation shoulder sleeve, having a manipulation

shoulder corresponding to the implant shoulder is pushed over the manipulation implant until the manipulation shoulder is held by the snap element of the impression cap. Modelling compound is lastly poured onto the impression and the master cast is obtained.

5 In said US 6 068 478 (Grande et al.), another impression method is used if another type of superstructure, for example an angled superstructure is attached to an implant. In this case, an impression cylinder is screwed onto the superstructure and a laterally open impression cap is pushed onto the superstructure such that it grabs the implant shoulder. The impression is taken using the impression tray filled with  
10 impression compound, which impression is obtained after withdrawing the impression tray, and in which the impression cap and a hollow space according to the impression cylinder and the conical superstructure remain behind. In the next step, the impression cylinder is pushed into its hollow space and the manipulation shoulder sleeve is attached, and modelling compound is then filled through the manipulation  
15 shoulder sleeve so that the whole hollow space is filled up. Modelling compound is now poured onto the impression and, after removing the impression tray in which the impression cylinder remains, the finished master cast is obtained.

It is further mentioned that the slide sleeve might be omitted if the hollow space remaining in the impression cap, and left by the selected abutment inside the  
20 impression cap, is filled with impression compound. Also, the slide sleeve and the impression cap may be combined and designed as one piece.

US 6 159 010 (Rogers et al.) discloses a dental coping for placement over an abutment post that is attached to and protruding above a dental implant. The coping includes a base portion having an internally tapered surface for mating with a support  
25 surface of the implant. A wall extends away from the base portion for enveloping the abutment post. The wall includes at least one aperture for allowing wax material to pass therethrough when taking an impression of the implantation site.

US 5 688 123 (Meiers et al.) discloses a transfer cap for dental implants that is to be used when taking an impression for forming a master cast model. This transfer  
30 cap is adapted in form and size to the built-up part or abutment of the implant and carries one or more resilient flaps extending over the shoulders of a conical area of the built-up part.

WO99/29255 (Morgan) discloses an abutment analogue having a head portion being formed with retention means such as an annular groove.

EP 0 190 670 (Lustig) discloses a prefabricated abutment that may be used in combination with a prefabricated sleeve-like coping which is telescopically mated to the post.

An object of this invention is to provide components for a system for improved function when using pick-up impression methods, and a method using said components.

10

### **Summary of the Invention**

In a first aspect of the invention, the above object is achieved by an abutment for connection of a dental component to an implant, said abutment comprising an implant contacting region and a component support region, said component support region having a maximum diameter and extending coronally of said maximum diameter to a coronal end. Said component support region is provided with a component engagement means being arranged for releasable engagement with said component by linear displacement of said dental component in relation to said abutment. Said component engagement means is located at a position closer to said maximum diameter than to the coronal end of the component support region.

The term "coronal" is here and throughout this application used to indicate a direction towards a head end or trailing end of the component discussed. For example, in a situation where an abutment is connected to an implant, the coronal direction would be a direction towards the part of the abutment being directed away from the implant. Likewise, the term "apical" indicates a direction towards an insertion end of the component. For an abutment connected to an implant, the apical direction would be a direction towards the implant. Thus, apical and coronal are opposite directions.

However, if parts of a component or a system are angulated in relation to each other, the apical and coronal directions of the different parts, respectively, may not be coinciding. For example, this would be the case for an abutment where the component support region of an abutment is angled in relation to the implant

30

contacting region, a so called angled abutment. Herein, when discussing the apical direction of the component support region, a direction towards the maximum diameter of the component support region is referred to. The coronal direction of a component support region is a direction away from said maximum diameter, towards  
5 a free end of the component support region.

The component engagement means is arranged for releasable engagement with said component, said engagement being accomplished by linear displacement of said dental component in relation to said abutment. In particular, the engagement should be releasable by linear displacement only of the component in relation to the  
10 component support region. This is advantageous since the component engagement means might among other functions be used for locking an impression coping for pick-up impression making to the abutment. In pick-up impression making, any rotational movements between the impression coping and the abutment when releasing the coping from the abutment should preferably be avoided.

The retaining force of the engagement between the abutment and the component may be selected for different applications. For connection of an impression coping for pick-up impression making to the abutment, the retaining force should be large enough to securely retain the impression coping on the abutment in a well defined position, but not so large that the impression coping may not easily be  
20 removed from the abutment together with impression material into which it is embedded.

Further, the component engagement means should preferably provide a stable locking of the component to the abutment at a well defined location on the abutment. For the above mentioned use with impression copings, it is advantageous that a  
25 prosthesis manufactured after master-cast making may be attached to the abutment in the same position as the impression coping had during the previous impression making by which said master cast was made.

The component engagement means is provided at a component support region of the abutment, which is extending coronally of a maximum diameter of the  
30 component support region of the abutment. This arrangement provides advantages over prior art where a portion providing a maximum diameter of an abutment or implant is used as a locking means for retaining impression components. Thus, in this

prior art, components to be attached to the locking means will need to have a maximum outer diameter larger than the maximum diameter of the abutment or implant in order to be seated thereto. Since in these prior art systems the maximum diameter is provided at a position down in the soft gingival tissue overlying the bone tissue where the dental implant is situated, this means that the gingival tissue will have to be pushed aside and risks being damaged when attaching a component to the abutment. Also, the large diameter of the component may make it difficult to attach or remove the component from the abutment without said component colliding with possible teeth adjacent to the implant. Where the adjacent teeth are very close set, the diameter of the component might even be too large for the component to pass between the teeth to be set on the abutment. However, the arrangement disclosed above diminishes these problems in providing a possibility of attaching components having a relatively small outer diameter to the abutment.

Further, the component engagement means of the present abutment is provided closer to a maximum diameter of the component support region than to a coronal end of said region. This provides an advantage in that a relatively large portion of the component support region will extend coronally of the component engagement means. Consequently, said portion of the component support region may be modified by the dental technician, without compromising the function of the component engagement means. Such modifications are sometimes made for customising standard abutments so as to adapt to the needs of an individual patient. Thus, the specified position of the component engagement means allows components to be attached to the abutment independent of whether the latter has been modified or is left in an original standard appearance.

The component engagement means being provided closer to said maximum diameter than to the coronal end of the abutment means that it is provided at a distance from said maximum diameter being less than 50% of the distance between said maximum diameter and said coronal end of the abutment. Advantageously, it may be provided at a position from said maximum diameter being less than 35 % of the distance between said maximum diameter and said coronal end of the abutment, and most preferred less than 25 %.



According to a second version of the first aspect of the invention there is provided an abutment for connection of a dental component to an implant, comprising an implant contacting region and a component support region, said component support region having a maximum diameter and comprising a shoulder portion presenting an outer surface, and a post portion extending coronally from said shoulder portion to a coronal end of the abutment and presenting an outer surface forming an angle less than  $180^\circ$  with said outer surface of said shoulder portion. A component engagement means is arranged for releasable connection of said component to said abutment by linear displacement of said component in relation to said abutment. Said component engagement means is provided at the post portion, at a position being closer to the shoulder portion than to said coronal end of the abutment.

It lies in the term "shoulder portion" of the component support region that it should be structured and adapted to support a component at least partly from "below", that is from the apical direction. In other words, the projection of a normal to the outer surface of the shoulder portion onto the longitudinal axis of the component support region would extend in the coronal direction.

In contrast, the post portion of the component support region may have an outer surface being parallel to a longitudinal axis of the abutment, that is, a normal of said outer surface is directed transversely to said longitudinal axis. However, there are other alternatives, and perhaps more advantageous, where the outer surface of the post portion is forming an angle with the longitudinal axis.

The definitions and advantages over prior art described in relation to the first variant of the abutment are equally applicable for this second variant of the abutment.

In addition, in this second variant, the shoulder portion residing apically of the component engagement means will provide a stable base for support of said component, independently of whether the post portion of the abutment is modified or not. This is particularly advantageous if the post part is modified in a way that compromises its function for supporting a component. For example, if a component is adapted to the abutment, having an inner surface closely following the post portion and the shoulder portion, it will be in contact with both the post portion and the shoulder portion if set on an abutment having its original shape. However, if the post portion is customised, the component seated on the abutment will not follow the new

customised outer contour of the post portion. Anyway, such a component may be securely seated on the abutment, since the shoulder portion rests unmodified and may provide the necessary support.

5 A stable and repeatable placement of components on the abutment is particularly important when using pick-up impression techniques, in order to provide an accurate master cast model and a correctly located prosthesis.

The component engagement means is provided closer to said shoulder portion than to the coronal end of the abutment such that the component engagement means is provided at a distance from said shoulder portion less than 50% of the distance  
10 between said maximum diameter and said coronal end of the abutment. Advantageously, it may be provided at a position from said shoulder portion being less than 30 % the distance between said maximum diameter and said apical end of the abutment, and most preferred less than 20%.

Preferably, the angle between the outer surface of said shoulder portion and  
15 the outer surface of said post portion is in the range 100 to 160°, more preferred 120 to 150°, most preferred 130 to 140°.

Advantageously, said component engagement means may be provided at a transition between said post portion and said shoulder portion. This location maximises the part of the post portion extending coronally of the component  
20 engagement means, and thus the part of the abutment being available for modification by a dental technician.

Returning now to the shapes of said post portion and shoulder portion, the outer surface of the post portion may advantageously be tapering inwardly in a coronal direction of the abutment. The taper has the advantage that it allows more  
25 lateral play in an initial stage of attaching a component to the post portion, as is common for example with impression caps. With a post portion having an outer surface being parallel to said longitudinal axis, any component to be threaded on the post portion must be brought into axial alignment with the post portion. However, if the post portion is having a conical outer surface a certain misalignment when starting  
30 the attachment is possible. Also, the taper may contribute to providing an engagement function with said component.

In particular, an outer surface of the post portion forming an angle preferably less than  $20^\circ$ , more preferred less than  $15^\circ$ , most preferred  $6^\circ$  with a longitudinal axis of the abutment has been found to be useful.

Also the shoulder portion might advantageously taper inwardly in a coronal direction of the abutment. In particular, the conical outer surface of the shoulder portion may form an angle in the range  $40$  to  $60^\circ$ , preferably  $50^\circ$  with a longitudinal axis of the abutment.

One embodiment of an abutment according to any of the two variants of the first aspect of the invention described above is further having an extension region being provided between said implant contacting region and said component support region. Such an extension region is useful to extend the height of the abutment so as to pass through the gingival soft tissue overlying the bone tissue where the implant is placed.

The outer surface of said extension region may be parallel to a longitudinal axis of the abutment, or it may be tapering outwardly in a coronal direction.

In an abutment according to this embodiment, also including a post portion and a shoulder portion, the extension region may favourably be arranged such that the transition between said extension region and said shoulder portion defines the maximum diameter of the abutment.

With the abutments according to said first aspect of the invention, said component engagement means might advantageously comprise at least one protrusion or indentation in an outer surface of said component support region. Such a protrusion or indentation might for example be a rib or groove extending at least partly around a circumference of the outer surface of said component support region. These shapes are particularly useful to provide an engagement means onto which components may be snap-locked.

In a second aspect of the invention, there is provided a series of abutments according to said first aspect of the invention, each abutment having a maximum diameter of said component support region, and said maximum diameter being constant for all abutments in said series.

Alternatively, there is provided a series of abutments according to said second variant of the first aspect of the invention, wherein said angle formed between said

outer surface of the post portion and said outer surface of the shoulder portion is constant for all abutments in said series. This feature makes it possible to use components having the same shape although not necessarily the same size for different abutments in said series.

5 Also, there is provided a series of abutments according to said second variant, wherein each abutment is having a longitudinal axis and further comprising an implant contacting region and an extension region extending between said implant contacting region and said component support region, wherein

10 - said extension region presents an outer surface forming an angle ( $\phi$ ) with said longitudinal axis,

- said shoulder portion presents an outer surface tapering inwardly in a coronal direction, said outer surface forming an angle ( $\chi$ ) with said longitudinal axis,

15 - said post portion extending coronally from said shoulder portion and presenting an outer surface tapering inwardly in a coronal direction forming an angle ( $\phi$ ) with said longitudinal axis being less than the angle ( $\chi$ ) formed by the outer surface of the shoulder portion with said longitudinal axis, wherein,

said angle ( $\chi$ ) between the outer surface of the shoulder portion and the longitudinal axis and said angle ( $\phi$ ) between the outer surface of the post portion and said longitudinal axis are constant for all abutments in said series,

20 whereas the angle ( $\phi$ ) between the outer surface of the said extension region and said longitudinal axis varies between different abutments in said series.

According to this embodiment, the angles of the component support region are fixed, leading to the advantage of enabling conformity in the shape of components adapted for different abutments.

25 In a third aspect of the invention, there is provided an abutment replica, comprising a component support region having a similar outer shape as the outer shape of the component support region of an abutment according to said first aspect of the invention, including the component engagement means.

30 In an embodiment of said replica it further comprises a bore extending from an apical end of said replica, at least to a position coronally of said component engagement means. In this embodiment, at least part of the component support region may be cut off, leaving a replica comprising a remaining apical region and the

component engagement means of the support region and being provided with a through bore. This possibility is used when making a master cast of a modified abutment, which will be described in more detail in the specific part of the description. The replica according to this embodiment is advantageous since it may  
5 be used both for situations where the abutment is left in its standard appearance (in its original state) and for situations where the abutment is modified (in a cut-off state).

According to a fourth aspect of said invention, there is provided an impression coping for pick-up impression making of a dental abutment attached to a dental implant, comprising an abutment surrounding region for surrounding said abutment,  
10 said abutment surrounding region having an apical end and a coronal end, and having an inner wall being provided with abutment engagement means being arranged for releasable engagement with said abutment by linear displacement of said impression coping in relation to said abutment, said component engagement means being located closer to said apical end than to said coronal end.

15 In prior art systems, locking means such as flaps are sometimes provided at the end of an impression cap for engagement over and around an abutment. In these constructions, the locking means will contribute to an enlarged outer diameter at the apical end of the impression cap, leading to unnecessary compression of the soft gingival tissue surrounding the abutment. Further, the placement of the locking means  
20 at the end of the impression caps often leads to a low attachment level of the cap down in the gingival tissue of the patient.

In other prior systems there are locking means provided close to the coronal end of the impression cap. These systems have the disadvantage that the abutment on which the impression cap is to be seated may not be modified below said coronal end,  
25 if the impression cap shall still be attachable to the abutment.

The above mentioned disadvantages may be avoided by the location of said abutment engagement means on the inner wall of the impression coping, closer to said apical end than to said coronal end according to this third aspect of the invention.

30 In a first variant of said impression coping, the abutment surrounding region of the impression coping comprises a shoulder contacting portion having an inner wall and a post surrounding portion extending coronally from said shoulder contacting portion and presenting an inner wall forming an angle larger than 180°

with said inner wall of said shoulder contacting portion, wherein said abutment engagement means are provided at the post surrounding portion, at a position being closer to the shoulder contacting portion than to the coronal end of the abutment surrounding region.

5           The shoulder contacting portion is intended to contact a shoulder portion of a corresponding abutment. Accordingly, the projection of a normal to the inner wall of said shoulder contacting portion onto a longitudinal axis of the component surrounding region would extend in the apical direction.

          The post surrounding portion may have an inner wall having various shapes. It  
10   may be formed such that the entire inner wall contacts a post portion of an abutment. However, it may also be formed so as to contact the post portion of an abutment only with a part of said inner wall. Some such embodiments will be described below.

          In first variant of the impression coping, the location of the abutment engagement means on the inner wall of a post surrounding portion extending from a  
15   shoulder contacting portion results in a position of the locking means at a site where the diameter of the abutment on which the impression coping is to be seated is relatively small, as compared to the diameter at a shoulder portion of the abutment. Thus, this location of the locking means allows more construction variations of the locking means to be used without having to increase the outer diameter of the  
20   impression coping at the locking means beyond the maximum diameter of said abutment.

          Further, the shoulder contacting portion is useful for increasing contact and stability when interacting with said abutment. This is particularly important as the impression coping will be used in pick-up impression methods, where it will first be  
25   attached to an abutment being fixed to an implant, thereafter be embedded in impression material and removed from the abutment together with said impression material, and finally an abutment replica will be inserted into said impression coping. For success of this method, both the abutment and the abutment replica should be securable in the impression coping with good accuracy, which said shoulder  
30   contacting portion contributes to.

          Preferably, said abutment engagement means is provided at a distance from said shoulder contacting portion being less than 50% the distance between said

shoulder portion and said coronal end, preferably less than 30 %, most preferred less than 20%.

The abutment engagement means may be provided at a transition between said post surrounding portion and said shoulder contacting portion. Further, the abutment engagement means may comprise at least one protrusion or indentation, such as a rib or groove, in an inner wall of said abutment surrounding region .

Preferably, the impression coping is having a through passage extending from a coronal end to an apical end of the impression coping. This is advantageous since impression material may then be introduced through the coronal end into the impression coping, thus increasing the fixation of the impression coping in the impression material. Also, in this embodiment the impression material introduced into the impression coping will contact part of the abutment, and thus provide an open space replicating said abutment part. This open space may be used for guiding the later introduction of an abutment replica, or as will be described in the detailed part of the description, as a form for forming a model of a customised abutment.

According to a second variant of the impression coping there is provided an impression coping being having a through passage, a longitudinal axis and an abutment surrounding region, wherein the inner walls of said abutment surrounding region comprises at least one abutment contact surface for contact with said abutment, and at least one space forming surface to be spaced apart from said abutment in order to provide a space between said space forming surface and said abutment, and, in a transversal section of said post contacting region, a radial distance from said longitudinal axis to said post contact surface is shorter than a radial distance from said longitudinal axis to said space forming surface.

According to this second variant of an impression coping, impression material may be introduced in said space between said space forming surfaces and said abutment. However, there are also abutment contact surfaces, that contacts the abutment thus providing a stable contact surface. This embodiment is particularly useful in that it may advantageously be used for taking impressions of both standard and modified abutments, as will be described below.

When taking an impression of a standard abutment, the abutment contact surfaces will contact the standard abutment. Impression material may optionally be

introduced into the spaces formed by the space forming surfaces, but this is not necessary. The abutment contact surfaces will namely normally provide enough surface to guide the later insertion of an abutment replica into exactly the same position as the abutment had inside the impression coping.

5           However, when taking an impression of a modified abutment, all of the abutment contact surfaces will probably not be in contact with the modified abutment. At least a portion of the abutment contact surfaces will most likely not contact the customised abutment, due to the modified shape thereof. In this case a composite space is formed between the abutment and the inner wall of the impression coping, 10 said composite space being composed by a space created between the abutment contact surface and the modified abutment and said space between said space forming surface and said abutment. Impression material may be introduced into the impression coping and into the composite space formed between said impression coping and the modified abutment. Thus, when removed from the abutment, the 15 impression material together with the impression coping will form an empty space having an inner "modified" shape corresponding to the shape of the modified abutment, said inner shape being subsequently used for moulding a model of said modified abutment.

          Preferably, said space forming surface may be provided with a vent for 20 passage of air from said composite space. Thus, when impression material is introduced into said composite space, air may flow through the space formed between said space forming surface and said abutment out through the vent, whereby air bubbles are avoided and proper introduction of impression material is ensured. The space forming surface thus provides an air duct for air evacuation from said 25 composite space.

          The vent may be provided by an opening in the space forming surface or possibly by a perforation or other suitable vent means.

          Naturally, the abutment may alternatively be modified such that all of the abutment contact surface is still in contact with the modified abutment, and the 30 composite space is related only to the space forming surfaces. The extent to which said composite space needs filling with impression material is dependent on the modification made of the abutment. However, complete filling may normally be



ensured by having impression material filled into the entire composite space and flowing out of said vent.

Advantageously, at least one abutment contact surface may be tapering inwardly in a coronal direction. This is particularly useful when the impression coping is to be seated on an abutment having a tapered outer shape.

Said first and second variants of an impression coping may advantageously be combined. The combination of a shoulder contacting portion and post contacting surfaces provides a possibility of ensuring that the impression coping is correctly placed on the abutment.

At least one abutment contact surface may be provided with a rotational locking means, for rotational locking of said impression coping on said dental abutment. This feature is useful for ensuring a proper transfer of the rotational direction of the abutment fixed to the implant to a master cast model via impression making.

For enhanced attachment into the impression material, the impression coping may be provided with a prolongation region coronally of the abutment surrounding region. Such a prolongation region will also make the impression coping easier to handle. Said prolongation region may further be provided with retention elements for retention of the impression coping in an impression material.

Finally, in a fifth aspect of the invention, there is provided a set comprising an abutment and an impression coping.

Further scope of applicability of the present invention will become apparent from the detailed description given hereinafter. However, it should be understood that the detailed description and specific examples, while indicating preferred embodiments of the invention, are given by way of illustration only, since various changes and modifications within the spirit and scope of the invention will become apparent to those skilled in the art from this detailed description.

### **Brief Description of the Drawings**

The present invention will become more fully understood from the detailed description given hereinbelow and the accompanying drawings which are given by

way of example only, and thus are not limitative of the present invention, and wherein:

- Figs 1a to 1e depicts a first embodiment of an abutment
- Figs 2a to 2b depicts a second embodiment of an abutment
- 5 Fig. 3 depicts a third embodiment of an abutment
- Fig. 4 depicts a fourth embodiment of an abutment
- Figs 5a to 5h depicts an embodiment of a series of abutments
- Figs 6a to 6b depicts an embodiment of an abutment replica
- Figs 7a to 7f depicts an embodiment of an impression coping
- 10 Figs 8a to 8b depicts an embodiment of an abutment as attached to a dental implant, with an embodiment of an impression coping attached to said abutment
- Figs 9a to 9b depicts an embodiment of an abutment carrier
- Figs 10a to 10h describes a method for pick up impression making of a standard abutment
- 15 Figs 11a to 11h describes a method for pick up impression making of a modified standard abutment

### **Detailed Description of Preferred Embodiments**

Fig. 1a is a perspective view of a first embodiment of an abutment, whereas  
20 Figs 1b to 1e are lateral views of the same abutment as in Fig. 1a.

Turning first to Figs 1a and 1b, an abutment for connection of a dental component to an implant is depicted. The abutment comprises an implant contacting region 2 for connection to a dental implant and a component support region 3, extending coronally of said implant contacting region 2, for connection of a dental  
25 component thereto.

Typically, the abutment would be used for connection of a dental prosthesis or crown to the implant. However, during the procedure of manufacturing the final prosthesis, the abutment would be used for connecting other components to the implant, such as for example impression copings, healing caps or a temporary  
30 prosthesis. The abutment 1 may be made of a suitable material for dental components to be permanently installed in the mouth, such as for example titanium and certain ceramic materials, for example zirconium oxides.

The component contacting region 3 is extending coronally from a maximum diameter A (see Fig. 1c) to a coronal end 6. The maximum diameter A of the component contacting region is in this case coinciding with the maximum diameter of the abutment as a whole.

5           Component engagement means 9 are provided at the component support region 3, coronally of the maximum diameter A. The component engagement means is structured and adapted for releasable engagement with a component by linear displacement of said component in relation to said abutment.

10           The locations of the component engagement means 9 coronally of the maximum diameter A results in the attachment of the component being made where the abutment has a relatively narrow diameter, which is advantageous since it allows the components to be attached thereto to be constructed with a relatively small outer diameter. A small outer diameter makes it easier to install the component on the abutment without being hindered by adjacent teeth or having to push aside and  
15           damage the gingival tissue surrounding the abutment 1, when installed.

            The component engagement means 9 are provided at a distance from said maximum diameter A being less than 50 % of the distance between the maximum diameter A and the coronal end 6 of the abutment. Preferably, the distance should be less than 35 %, and, as in the embodiment of Figs 1a to 1e, the component  
20           engagement means 9 are provided at a distance being less than 25 % of the distance between the maximum diameter A and the coronal end 6 of the abutment.

            The implant contacting region 3 comprises in this first embodiment a shoulder portion 4 and a post portion 5, extending coronally from said shoulder portion. The outer surface 8 of the post portion 5 is forming an angle  $\alpha$  less than  $180^\circ$  with the  
25           outer surface 7 of the shoulder portion. (See Fig. 1e). The angle  $\alpha$  formed between the outer surfaces 7, 8 of the shoulder portion 4 and the post portion 5 is preferably between  $100^\circ$  and  $160^\circ$ , more preferred 120 to  $150^\circ$ , most preferred 130 to  $140^\circ$ . In this embodiment, the angle  $\alpha$  is  $136^\circ$ .

            In this embodiment, the component engagement means 9 is provided at the  
30           transition between said shoulder portion 4 and post portion 5. This placement allows the major part of the post portion 5 to be modified without impairing the function of the component engagement means 9. The component engagement means 9 has the

shape of a groove extending around part of the circumference of the post portion 5. The groove may be described as formed by a transition part 5' of the post portion 5 having an outer surface 8' that forms an angle  $\delta$  with the outer surface of the post portion 5. The angle  $\delta$  is preferably in the range 10 to 40°, more preferred 10 to 30°  
5 degrees, most preferred 12°. Favourably, a component may be snap locked onto the groove formed by said transition part 5'. The angle  $\delta$  as defined above is suitable for forming such a snap lock having a preferred retaining force for securely retaining the component on the abutment 1 while still enabling the component to be released from said abutment 1.

10 As related to the shoulder portion 4, the component engagement means 9 is preferably provided at a distance from the shoulder portion 4 being less than 50%, more preferred less than 30 % and, as in this embodiment, less than 20 % of the distance from the shoulder portion 4 to the coronal end 6 of the abutment. A component engagement means 9 may be considered as being provided at a distance  
15 from the shoulder portion 4 being less than 50 % the distance between the shoulder portion 4 and the coronal end 6 if the component engagement means 9 is still providing a component retaining function if a coronal portion of the abutment corresponding to 50 % of the distance between the shoulder portion 4 and the coronal end 6 is cut off. (A corresponding definition applies to the situation where the  
20 location of the component engagement means 9 are related to the maximum diameter A.)

The post portion 5 is further provided with a rotational locking means 15 for rotational locking of a component attached to the abutment 1. In this case, the rotational locking means 15 is made out of a flat part of the outer surface 8 of the post  
25 portion 5. However, other shapes of the rotational locking means 15 may be considered. It is believed that a relatively smooth rotational lock function is preferred over more sharp and distinct locking means, since a smooth lock allows more play when installing a component on the abutment.

The apical end 6 of the post portion is optionally provided with a polygonal  
30 blind bore 19, serving as attachment for a wrench for screwing the abutment onto an implant.

Between the component support region 3 and the implant contacting region 2 there is provided an extension region 11, serving to increase the height with which the abutment 1 is extending over the implant when installed thereto. When installed to an implant being flush with bone tissue, the extension region 11 would typically extend  
5 through gingival tissue.

The implant contacting region 2 comprises a coronal contact portion 12 and a threaded shaft 16. The implant contacting region 2 is thereby adapted for connection to an implant having a conical coronal opening and being provided with internal threads for attachment of an abutment 1. The conical shape of the implant contacting  
10 region 2 and the implant opening, respectively, is particularly advantageous since it may be adapted to establish a conical seal when the implant and the abutment is screwed together.

In Fig. 1d the angles formed by the outer surfaces of different portions of the abutment 1 with a longitudinal axis L of the abutment are indicated.

15 The outer surface 8 of the post portion 5 is tapering towards the coronal direction of the abutment. This is believed to be advantageous, since it allows more lateral play in an initial stage of attaching a component to the abutment 1, than would be the case if the outer surface 8 of the post portion 5 was parallel to the longitudinal axis L. The angle  $\phi$  formed by the outer surface 8 of the post portion 5 with the  
20 longitudinal axis L is preferably less than  $20^\circ$ , more preferred less than  $15^\circ$ . In this case, the angle  $\phi$  is  $6^\circ$ .

The above mentioned values of the angle  $\phi$  are particularly suitable for providing a post portion 5 that may cooperate with a component to provide a retaining function between the post portion 5 and the component.

25 Returning now to the component engagement means 9 as previously described is formed by a transition part 5' of the post portion 5 having an outer surface 8' that forms an angle  $\delta$  with the outer surface of the post portion 5. The angle  $\delta$  may further be described in relation to the angle  $\phi$  between the longitudinal axis and the outer surface 8 of the post portion, as advantageously being  $2\phi \pm 10^\circ$ . This particular  
30 choice of angle  $\delta$  enables a component attached to the abutment to be released from said abutment by linear displacement with essentially the same force that was needed for attaching the component to said component engagement means. Seen from the

longitudinal axis L, the outer surface 8' of the transition part 5' of the post portion will namely be  $\phi \pm 10^\circ$ , while the outer surface 8 of the post portion 5 in general forms an angle  $\phi$  with said longitudinal axis L.

If using a component having an inner shape having at least some inner surfaces corresponding to the outer shape of the abutment, the force required for attaching the component onto the abutment will be dependent on the angle  $\phi$  formed by the outer surface 8 of the post portion 5 with said longitudinal axis L. The force required for removing the component from the abutment will be dependent on the angle formed by the outer surface 8' of said transition portion 5' with said longitudinal axis L. When the angle  $\delta$  is  $2\phi \pm 10^\circ$ , this angle will be  $\phi \pm 10^\circ$ , meaning that the force required for removing said component from said abutment is about the same as the force required for attaching said component to said abutment 1.

The outer surface 7 of the shoulder portion 4 is likewise tapering inwardly in a coronal direction. The angle  $\chi$  formed by the outer surface 7 of the shoulder portion 4 with the longitudinal axis L is preferably in the range 40 to 60°. In this case, the angle  $\chi$  is 50° degrees.

The before mentioned angle  $\alpha$  formed between the outer surface 7 of the shoulder portion 4 and the outer surface 8 of the post portion 5 would be equal to  $(180^\circ + \phi - \chi)$ .

The outer surface 13 of the extension region 11 may be parallel to a longitudinal axis of the abutment 1 or tapering outwardly in a coronal direction of the abutment 1. The angle  $\varphi$  formed by the outer surface 13 of the extension region 11 with said longitudinal axis L may advantageously be varied so as to achieve a desired maximum diameter A. Preferably, the angle  $\varphi$  would be 90° to 180°.

Finally, the angle  $\omega$  formed by the outer surface 14 of the coronal contact portion 12 of the implant contacting region 2 of the abutment 1, is preferably 165° to 170°, in this case 169°.

Turning to Fig. 1c, the maximum diameter A of the abutment 1 is preferably in the range 3 to 7 mm, most preferred 3 to 6 mm. The maximum diameter B of the post portion 5 is in the range 2 to 5 mm. A shelf formed by the outer surface 7 of the shoulder portion 4 would in this embodiment have a width corresponding to half the

difference between said maximum diameter A of the abutment and the maximum diameter B of the abutment. Preferably, this width may be in the range 0.2 to 1 mm, most preferred 0.5 mm.

5 The axial extension of the shoulder portion 4 may be in the range 10-40 %, preferably 20 % as compared to an axial extension of the entire component support region 3. The axial extension of the extension region 11 may advantageously be selected so as to achieve a desired height of the abutment. Normally, the extension region 11 would have an axial extension of about 10 % to 50% of the axial extension of the component support region 3.

10 Optionally, the abutment 1 may be provided with one or several markings 20 indicating a level for shortening of the abutment.

Fig. 2a is a perspective view of a second embodiment of an abutment. Fig. 2b is a sectional view of the abutment of Fig. 2a. Features corresponding to features of the above mentioned first embodiment of Figs 1a to 1e have been provided with the same reference numerals as used in Figs 1a to 1e. Only the parts of this second  
15 embodiment that differ from the first embodiment will be described below.

The second embodiment differs from the first embodiment in that the implant contacting region 2 is not provided with a threaded shaft 16. Instead, it has a hexagonal locking structure 21 for rotational lock to an implant. The abutment 1 is further provided with a through bore 17 having an internal ledge 18. A screw may be  
20 inserted in the through bore 17, seating the screw head on the ledge 18, for connection of the abutment 1 to an implant. This type of abutment is particularly useful for single-tooth restoration situations.

Fig. 3 is a side view of a third embodiment of an abutment. Features  
25 corresponding to features of the above mentioned first embodiment of Figs 1a to 1e have been provided with the same reference numerals as used in Figs 1a to 1e. Only the parts of the third embodiment that differ from the first embodiment will be described below.

The third embodiment of the abutment differs from the first embodiment  
30 mainly in the height and shape of the post portion 5. The height of the post portion 5 is shortened as compared to the first embodiment, and constitutes approximately 75 to 80 % of the axial extension of the component support region 3. (This leaving about 20

to 25 % of the axial extension to the shoulder portion 4). The actual length of said post portion is about 2 mm. The angle  $\phi$  formed by the outer surface 8 of the post portion 5 with the longitudinal axis L is  $11^\circ$ .

5 An advantage with using an abutment 1 with a short post portion 5 is that the abutment 1 will not need being modified very often. Instead, the prosthesis may be built on the post portion 5 in its original shape.

Fig. 4 is a side view of a fourth embodiment of an abutment 1. Features corresponding to features of the above mentioned first embodiment of Figs 1a to 1e have been provided with the same reference numerals as used in Figs 1a to 1e. Only  
10 the parts that differ from the first embodiment will be described below.

The fourth embodiment differs from the first embodiment in that the extension region 11 is made very short and its outer surface 13 is forming a rather large angle  $\phi$  with said longitudinal axis L.

15 Figs 5a to 5h depicts an embodiment of a series of abutments of the types described in Figs 1a to 4. The reference numerals in the following description of Figs 5a to 5h may be referred to features described in Figs 1a to 4.

Figs 5a to 5h depicts a series of abutments wherein the angle  $\alpha$  formed between the outer surface 8 of the post portion 5 and the outer surface 7 of the shoulder portion 8 is constant for all abutments in said series. Further, the  
20 longitudinal extension of a component support region 3 is constant between all abutments in said series.

Turning to Figs 5a to 5c only, these three abutments further belong to a series in which the maximum diameter A is constant for all abutments in said series. Likewise, the three abutments of Figs 5d to 5f have a common maximum diameter,  
25 and the two abutments of Figs 5g to 5h have a common maximum diameter. The abutments of Figs 5a to 5c have a maximum diameter of 4 mm, the abutments of Figs 5d to f have a maximum diameter of 5 mm, and the abutments of Figs 5 g and 5h have a maximum diameter of 6 mm.

30 Figs 5a to 5h describes a series of abutments 1 for connection of a dental component to an implant, each abutment having a longitudinal axis L and comprising an implant contacting region 2, a component support region 3 and an extension region 11 there between 3, wherein



- said extension region 11 presents an outer surface 13 forming an angle  $\phi$  with said longitudinal axis L,  
- said shoulder portion 4 presents an outer surface 7 tapering inwardly in a coronal direction and forming an angle  $\chi$  with said longitudinal axis L,  
5 - said post portion 5 extending coronally from said shoulder portion 4 and presenting an outer surface 8 tapering inwardly in a coronal direction and forming an angle  $\phi$  with said longitudinal axis L being less than the angle  $\chi$  formed by the outer surface 7 of the shoulder portion 4 with said longitudinal axis L, wherein,  
said angle  $\chi$  between the outer surface 7 of the shoulder portion 4 and the  
10 longitudinal axis L and said angle  $\phi$  between the outer surface 8 of the post portion 5 and the longitudinal axis L are constant in all abutments in said series,

whereas the angle  $\phi$  between the outer surface 13 of said extension region 11 and said longitudinal axis L varies between different abutments in said series.

Fig. 6a is a perspective view of an embodiment of an abutment replica 101,  
15 and Fig. 6b is a side view of the same abutment replica 101.

The abutment replica 101 comprises a component support region 103, an extension region 111 and an apical region 102. The component support region 103 replicates the component support region of an abutment 1, in this case an abutment 1 of the type depicted in Figs 1a to 1e. Thus the component support region 103 has a  
20 shoulder portion 104 with an outer surface 107 and a post portion 105 with an outer surface 108.

In particular, the abutment replica 101 is provided with component engagement means 109 replicating the component engagement means 9 of the abutment 1.

25 Also, the abutment replica 101 is provided with a bore 130 extending from an apical end of the apical portion 102 to a position coronally of said component engagement means 109. In this embodiment, the bore 130 is a blind bore, but one could also consider having a bore extending all the way through the replica 101.

The bore 130 becomes useful in situations where the abutment replica 101  
30 should be used for model making of a modified standard abutment, as is described in more detail in relation to Figs 11a to 11h below.

In such situations, a coronal part of the post portion 105 is cut off the abutment replica 101, leaving the remaining abutment replica 101 with a through bore 130 extending therethrough. The through bore 130 may be used for pouring moulding material from the apical end of the replica 101 for making a model of a modified  
5 abutment.

Thus, the abutment replica 101 is useful in pick-up impression making, regardless of whether standard or modified abutments are used.

The use of the marking 20 of the abutment 1 of Figs 1a to 1e, and the marking 120 on the abutment replica 101 will now be described. Preferably, there is provided  
10 a set comprising an abutment 1 having a coronal abutment end 6 and a corresponding replica 101 having a coronal replica end 106, said abutment 1 being provided with a marking for optional shortening of the abutment 1 at a first distance from the coronal abutment end 6, wherein said replica 101 is provided with a marking at a second distance from the coronal replica end 106 being equal to or slightly less than said first  
15 distance.

Such a set provides an alternative to other modification of the abutment. In case only a shortening of the abutment 1 is desired, the dental technician may shorten the abutment 1 at the marking 20. The replica 101 is provided with a corresponding marking 120 at approximately the same height as the marking of the abutment 1.  
20 Thus, the dental technician need not use specific impression techniques for capturing the modified shape of the abutment 1 when shortened, but can instead use standard techniques only to capture the location of the abutment 1. When making a master cast model, the replica 101 is shortened to the same extent as were the abutment 1, and will thus faithfully replicate the situation in the mouth.

25 Since it is difficult to cut off the abutment 1 and the replica 101 exactly at the marking, the marking of the replica 101 may advantageously be made at a distance from the replica end 106 being slightly less than the corresponding distance on the abutment 1. This is to provide a small margin for the dental technician when cutting of the components, without risking that the abutment replica 101 turns out to be  
30 shorter than the abutment 1.

The replica 101 and abutment 1 may each be provided with several markings.

Figs 7a and 7b are perspective views of an embodiment of an impression coping for pick up impression making of a dental abutment attached to a dental implant. Fig 7c is a bottom view of the same impression coping, Fig. 7d is a sectional view seen from the plane d-d in Fig. 7a, Fig. 7e is a sectional view seen from the plane e-e in Fig. 7a, and Fig. 7f is a sectional view from the plane f-f in Fig. 7a.

The impression coping as described in Figs 7a to 7f comprises an abutment surrounding region 203 for seating on an abutment 1. The abutment surrounding region 203 has a coronal end 206 and an apical end 240, and is provided with an inner wall 207, 208.

In this embodiment, the abutment surrounding region 203 comprises a shoulder contacting portion 204 having an inner wall 207 and a post surrounding portion 205 having an inner wall 208. The shoulder contacting portion 204 is intended to be seated on a shoulder portion of a corresponding abutment, whereas the post surrounding portion 205 will surround a post portion of said abutment.

On the inner wall 208 of the post surrounding portion 205, right at the transition between the post surrounding portion 205 and the shoulder contacting portion 204, abutment engagement means 209 are provided for releasable engagement with an abutment by linear displacement of said impression coping in relation to said abutment.

Said abutment engagement means 209 is provided closer to the apical end 240 of the abutment contacting portion 203 than to the coronal end 206. Preferably, the distance between said apical end 240 and the abutment engagement means 209 is less than 50%, more preferred less than 35%, most preferred less than 25% the distance between the apical end 240 and the coronal end 206 of the abutment surrounding region 203.

As related to the shoulder contacting portion 204, a distance between said shoulder contacting portion 204 and the abutment engagement means 209 is preferably less than 50% the distance between the shoulder contacting portion 204 and the coronal end 206 of the abutment surrounding region 203, more preferred less than 30%, most preferred less than 20%.

In this embodiment, the abutment engagement means 109 comprises a rib extending around part of the inner circumference of the inner wall 208 of the post

surrounding portion 205. The rib is interrupted by the provision of flat surface functioning as a rotational lock 215 extending on the inner wall 208 of the post portion 205. It is further interrupted where space forming surfaces 244 are provided, said surfaces 244 being described further below.

5           The rib functions as a snap lock means when cooperating with a corresponding groove of an engagement means 9 on an abutment 1, realisably locking the impression coping 201 in an axial direction on the abutment 1.

          The inner wall 208 of the post contacting region 205 comprises surface regions having different purposes. A first surface region is an abutment contact surface 243 for contact with the abutment 1 when seated. A second surface region is a space forming surface 244, that is spaced apart from the abutment 1 when seated, forming an open space between the abutment 1 and the space forming surface 244.

          The abutment contact surface 243 serves to stabilise the impression coping 201 when seated on an abutment 1, and to ensure that the impression coping 201 is correctly positioned.

          The space forming surface 244 serves to provide an open space between the abutment 1 and the inner wall 208 of the impression coping 201. This is particularly useful when taking an impression of a modified standard abutment, as is described in relation to Figs 11a to 11h below.

20           In a transversal section of the abutment surrounding region 203, a distance  $r_1$  from a longitudinal axis L of the impression coping 201 to an abutment contact surface 243 is shorter than a distance  $r_2$  from said longitudinal axis L to a space forming surface 244. This distinction is possible since abutments 1 are usually symmetrical or close to symmetrical around a longitudinal axis, why an asymmetrical inner surface of the impression coping 201 generally means that spaces between the impression coping 201 inner surface and the abutment 1 will be provided when the impression coping 201 is attached to the abutment 1.

          Put another way, the space forming surface 244 is a surface deviating from an outer contour of a corresponding abutment, while the abutment contact surface 243 is a surface following said outer contour.

30           Preferably, said space forming surface 244 may be provided with a vent 245 for passage of air from said space formed between the space forming surface 244 and

a corresponding abutment, when the impression coping 201 is seated on said abutment. When impression material is introduced into at least part of said space, air may flow from said space out through the vent 245, whereby air bubbles are avoided and proper filling of the impression coping is ensured.

5 In the embodiment of Figs 7a to 7f, the vent 245 is an opening in the wall of said impression coping. The vent may also be provided by for example a perforation.

Advantageously, the space forming surfaces 244 are extending longitudinally along the inner wall 208 of the post surrounding portion. As such they may form ducts for air and sometimes impression material to flow through. Vents 245 may be  
10 provided at the apical end of such ducts, being the most advantageous location for ensuring that air is let out, provided the impression material is filled from a coronal end of the impression coping 201. Also, vents 245 may be dispersed over the space forming surfaces.

The wording of the terms “space forming surface” 244 and “abutment contact  
15 surface” 243 is related to when the impression coping 201 is seated on an unmodified abutment. However, when taking an impression of a modified abutment, all of the abutment contact surface 243 will probably not be in contact with the modified abutment. At least a portion of the abutment contact surface 243 will most likely not contact the customised abutment, due to the modified shape thereof. In this case a  
20 composite space is formed between the abutment and the inner wall of the impression coping 201, said composite space being composed by a space between the abutment contact surface 243 and the modified abutment and a space between said space forming surface 244 and said modified abutment. Impression material may be introduced into the impression coping 201 and into the composite space formed  
25 between said impression coping 201 and the modified abutment. Thus, when removed from the abutment, the impression material together with the impression coping will form an empty space having an inner “modified” shape corresponding to the shape of the modified abutment, said inner shape being subsequently used for moulding a model of said modified abutment.

30 When the impression material is introduced into said composite space, air may flow through the space formed between said space forming surface 244 and said abutment out through the vent 245, whereby air bubbles are avoided and proper

filling of the impression coping is ensured. The space forming surface 244 thus provides an air duct for air evacuation from said composite space.

Naturally, the abutment may alternatively be modified such that all of the abutment contact surface is still in contact with the modified abutment, and the composite space is related only to the space forming surfaces.

The abutment contact surfaces 243 is tapering inwardly in a coronal direction, preferably forming an angle less than  $20^\circ$ , more preferred less than  $15^\circ$  with a longitudinal axis. In this case, said angle is  $6^\circ$ . Further, the abutment contact surfaces form an angle with the shoulder contacting portion 204, said angle being larger than  $180^\circ$ , preferably  $220$  to  $230^\circ$ .

The impression coping 201 is further provided with a prolongation region 241 being provided coronally of the abutment surrounding region 203. The prolongation region 241 serves to provide a larger area for the impression material to attach to the impression coping 201. Further, it facilitates handling of the impression coping 201. For better retention of the impression material, the prolongation region 241 is provided with laterally extending retention elements 242.

The impression coping may preferably be made of a plastic material. Such a plastic material may be selected so as to provide sufficient elasticity to allow formation of a snap lock means, but not being easily deformable so that the stable transfer of location of an abutment during impression making is not impaired.

In Figs 8a and 8b an abutment 1 is shown as attached to a dental implant 401 implanted in bone tissue 500. An impression coping 201 is connected to the abutment 1. Both Fig. 8a and Fig. 8b are cross-sectional views, Fig. 8b being taken through the plane b-b in Fig. 8a.

The abutment 1 is of the type described in Figs 1a to 1e, and the impression coping 201 of the type described Figs 7a to 7f. The reference numerals used in the descriptions of the abutment 1 and the impression coping 201 will be used in the following, although they are not set out in Figs 8a and 8b for lack of space.

The abutment 1 is connected to the dental implant 401 via the implant contacting region 2 of the abutment. The threaded shaft 16 is threaded into internal threads of a coronal bore of the implant. The coronal contact portion 12 of the implant

contacting region 2 is in sealing contact with a conical portion of said coronal bore of the implant 401.

The extension region 11 of the abutment is extending from implant coronal end through the gingival tissue 501. The outer diameter of the abutment is increasing  
5 from the implant contacting region 2 to a maximum diameter A at the coronal end of the extension region 11.

The component support region 3 with the shoulder portion 4 and the post portion 5 is extending above the gingival tissue 501. The component engagement means 9 is provided at the transition between the shoulder portion 4 and the post  
10 portion 5, thus coronally of both the maximum diameter A of the abutment 1, and of the shoulder portion 4.

The impression coping 201 is realisably locked to the component engagement means 9 of the abutment 1 by its own abutment engagement means 209. As seen in Figs 8a and 8b, the maximum diameter of the impression coping 201 is about as large  
15 as the maximum diameter A of the abutment 1. The impression coping 201 is thus easily connectable to the abutment 1 without risk of damaging the mucosal tissue surrounding the abutment. This would also be the case if the mucosal tissue were somewhat thicker, extending further coronally on the abutment.

In Fig. 8a it is seen that the space forming surfaces 244 of the impression  
20 coping 201 is spaced from the abutment 1. The spaces thus provided form ducts extending from the coronal end of the through passage 217 of the impression coping 201 along the side of the abutment and to the vents 245. In Fig. 8b, the abutment contact surfaces 243 is seen to contact the abutment 1, providing support and guidance for said impression coping 201.

Figs 9a to 9b are perspective views of another component that may be  
25 connected to an abutment as shown in Figs 1a to 1e. The component is an abutment carrier 301, having an apical abutment contact portion and a coronal extension portion having a ribbed outer surface to facilitate gripping of the component. The abutment carrier 301 may be attached to the abutment for facilitating handling and  
30 attachment of the abutment to an implanted fixture.

Figs 10 a to 10 b describes pick-up impression making and model forming when using a standard abutment 1.

In Fig. 10a, two dental implants 401 are shown as implanted flush with bone tissue 500 at an implantation site between adjacent teeth.

In Fig. 10b, it is illustrated how an abutment 1 is screwed into each of the implants 401 using an abutment carrier 301. The abutment 1 is attached to the carrier  
5 301 before being brought to the implantation site. The dental surgeon initially screws the abutment 1 into the implant 401 holding the carrier 301. Thereafter, the carrier 301 is removed, and the abutment 1 may optionally be further tightened to the implant 401 using a wrench.

In Fig. 10c, it is illustrated how impression copings 201 are attached onto the  
10 abutments 1 using the component engagement means 9 of the abutment 1 and the abutment engagement means 209 of the impression coping 201. Optionally, impression material may be introduced into the impression coping 201. However, since a standard abutment 1 is used, this is not necessary.

In Fig. 10d, impression material 600 has been applied, embedding the  
15 impression copings 201 in the impression material 600. The impression material 600 is let to harden so as to mimic the shape of the teeth adjacent the impression site and attach to the impression copings 201.

In Fig. 10e, the impression material 600 have been removed from the  
20 implantation site, bringing the impression copings 201 along embedded in the material 600.

In Fig. 10f it is depicted how standard abutment replicas 101 are introduced into the impression copings 201 attached in the impression material. Due to engagement means and rotational locking means on the abutment replicas 101 and impression copings 201, respectively, the abutment replicas 101 are placed in the  
25 impression copings 201 in a position corresponding to the initial position of the abutments 1 in the impression copings 201.

In Fig 10g, mould material 700 have been applied to the impression material 600.

Finally, in Fig 10h, the impression material 600 and the impression copings  
30 201 have been removed. The moulding material 700 now form a model of the implantation site with the adjacent teeth, and with the abutment replicas 101 corresponding to the abutments 1 at the actual implantation site. Using this model, a



proper prosthesis or crown may be manufactured and adjusted, for later installation on the proper abutments 1 at the installation site.

Figs 11a to 11h describes pick-up impression making and model forming when using a modified abutment 1.

5 In Fig. 11a, two dental implants 401 are shown as implanted flush with bone tissue 500 at an implantation site between adjacent teeth.

In Fig. 11b, it is illustrated how abutments 1 are screwed into the implants 401 using abutment carriers 301. The abutment 1 is attached to the carrier 301 before being brought to the implantation site. The dental surgeon initially screws the  
10 abutment 1 into the implant 401 holding the carrier 301. Thereafter, the carrier 301 is removed, and the abutment 1 may optionally be further tightened to the implant 401 by using a wrench.

Thereafter, the standard abutments 1 are modified for example as shown by removing a part of the coronal portion of the abutment 1. The remaining portion is a  
15 modified abutment 1'.

In Fig. 11c, it is illustrated how impression copings 201 are attached onto the modified abutments 1' using the component engagement means of the modified abutments 1' and the abutment engagement means of the impression copings 201, respectively. Since the abutments 1' are modified, it is necessary to introduce  
20 impression material 600' into the impression copings 201. The impression material 600' may advantageously be introduced through the coronal end of the through passage of the coping. When introducing impression material 600' through the coronal end of the through passage, air may flow through the spaces formed by the space forming surfaces 244 of the impression coping 201 and out of the vents 245,  
25 whereby air bubbles or inadequate filling of the impression coping 201 is avoided. If properly introduced, the impression material 600' together with part of the abutment contact surfaces 243 of the impression coping 201 will form an open space corresponding to the shape of the modified abutment 1'.

In Fig. 11d, impression material 600 has been applied, embedding the  
30 impression copings 201. The impression material 600 is let to harden so as to mimic the shape of the teeth adjacent the impression site and attach to the impression copings 201.

In Fig. 11e, the impression material 600 have been removed from the implantation site, bringing the impression copings 201 along.

In Fig. 11f it is depicted how a coronal portion is cut off a standard abutment replica 101, so as to reveal a bore passing through the remaining part of the replica 101'. The remaining part is referred to as a cut-off replica 101'. Cut-off replicas 101' are introduced into the impression copings 201 embedded in the impression material using component engagement means 109. Thereafter, mould material 700' is filled through the bore in the cut-off replica 101' into the open space formed by the impression material 600' inside the impression coping 201' and part of the abutment contact surfaces 243 of the impression coping 201.

In Fig 11g, further mould material 700 have been applied to the impression material 600.

Finally, in Fig 11h, the impression material 600 and the impression copings 201 have been removed. The moulding material 700 now forms a model of the implantation site with the adjacent teeth. The moulding material 700' that was filled through the cut-off replicas 101' replicates the upper part of the original modified abutments 1'. However, shoulder parts of the cut-off replicas 101' correspond to the shoulder parts of the original abutments 1 at the implantation site.

Using this model, a proper prosthesis or crown may be manufactured and adjusted, for later installation on the proper abutments 1 at the installation site.

It should be noted how the same abutments, impression copings and abutment replicas may be used both for the standard and the modified procedure.

Other alternatives and embodiments may be considered within the scope of the enclosed patent claims. For example, more than one component engagement means may be arranged on the abutment. In that case, there could possibly be a second component engagement means being provided coronally of the first component engagement means, although said second component engagement means may be destroyed when modifying the abutment. This could still be a functional alternative, providing said first component engagement means would provide the necessary component coupling function. The same applies for the abutment engagement means of the impression cap.

Also, the components described may possibly be consisting of two or more interconnected parts. However, the unitary embodiments described herein are preferred.

5 The construction of engagement means and rotational locking means may also be varied, as may the outer shape of for example the impression coping, the connection to an implant of the abutment or the apical portion of the abutment replica.

10 The invention being thus described, it will be obvious that the same may be varied in many ways. Such variations are not to be regarded as a departure from the spirit and scope of the invention, and all such modifications as would be obvious to one skilled in the art are intended to be included within the scope of the following claims.

CLAIMS

1. An abutment (1) for connection of a dental component to an implant, said abutment (1) comprising an implant contacting region (2) and a component support region (3), said component support region (3) having a maximum diameter (A) and extending coronally of said maximum diameter to a coronal end (6),

and being provided with a component engagement (9) being arranged for releasable engagement with said component by linear displacement of said dental component in relation to said abutment (1), said component engagement (9) being located at a position closer to said maximum diameter (A) than to said coronal end (6) of said component support region (3).

2. An abutment according to claim 1, wherein said component engagement (9) is provided at a distance from said maximum diameter (A) being less than 50 % of the distance between said maximum diameter (A) and said coronal end (6), preferably less than 35 %, most preferred less than 25 %.

3. An abutment (1) according to claim 1 or 2, wherein said component support region (3) comprises a shoulder portion (4) presenting an outer surface (7), and a post portion (5) extending coronally from said shoulder portion (4) to a coronal end (6) of the abutment and presenting an outer surface (8) forming an angle ( $\alpha$ ) less than  $180^\circ$  with said outer surface (7) of said shoulder portion (4).

4. An abutment (1) for connection of a dental component to an implant, comprising an implant contacting region (2) and a component support region (3), said component support region (3) having a maximum diameter (A) and comprising a shoulder portion (4) presenting an outer surface (7) and a post portion (5) extending coronally from said shoulder portion (4) to a coronal end (6) of the abutment and presenting an outer surface (8) forming an angle ( $\alpha$ ) less than  $180^\circ$  with said outer surface (7) of said shoulder portion (4), wherein

a component engagement (9) is arranged for releasable connection of said component to said abutment (1) by linear displacement of said component in relation to said abutment (1), said component engagement (9) being provided at said post portion (5), at a position being closer to said shoulder portion (4) than to said coronal end (6) of the abutment.

5. An abutment according to claim 3 or 4, wherein said component engagement (9) is provided at a distance from said shoulder portion (4) being less than 50 % of the distance between said shoulder portion (4) and said coronal end (6), preferably less than 30 %, most preferred less than 20 %.

6. An abutment according to any of the claims 3 to 5, wherein said angle ( $\alpha$ ) is in the range 100 to 160°, more preferred 120 to 150°, most preferred 130 to 140°.

7. An abutment according to any of the claims 3 to 6, wherein said component engagement (9) is provided at a transition between said post portion (5) and said shoulder portion (4).

8. An abutment (1) according to any of the claims 3 to 7, wherein said component engagement (9) is formed by a transition part (5') of said post portion (5) having an outer surface (8') that forms an angle ( $\delta$ ) with the outer surface (8) of the post portion.

9. An abutment (1) according to claim 8, wherein said angle ( $\delta$ ) is in the range 10 to 40°, more preferred 10 to 30° degrees, most preferred 12°.

10. An abutment (1) according to any of the claims 3 to 9, wherein the outer surface (8) of said post portion (5) is tapering inwardly in a coronal direction of said post portion (5) from a maximum post diameter (B).

11. An abutment (1) according to claim 10, wherein said post portion (5) has a longitudinal axis (L), and said outer surface (8) of the post portion (5) is forming an

angle ( $\phi$ ) being less than  $20^\circ$ , preferably less than  $15^\circ$ , most preferred  $6^\circ$  in relation to said longitudinal axis (L).

12. An abutment (1) according to claims 8 and 12, wherein said angle ( $\delta$ )  
5 formed by the outer surface (8') a transition part (5') of said post portion (5) with the outer surface (8) of said post portion (5) is  $2\phi \pm 10^\circ$ , where  $\phi$ , is the angle formed by said outer surface (8) of said post portion (5) with said longitudinal axis (L).

13. An abutment (1) according to any of the claims 3 to 12, wherein said  
10 outer surface (7) of said shoulder portion (4) is tapering inwardly in a coronal direction of said shoulder portion (4) from a maximum shoulder diameter (A).

14. An abutment (1) according to claim 13, wherein said abutment (1) has a  
longitudinal axis (L), and the outer surface (7) of the shoulder portion (4) forms an  
15 angle ( $\chi$ ) in the range  $40$  to  $60^\circ$ , preferably  $50^\circ$  degrees in relation to said longitudinal axis (L).

15. An abutment (1) according to any of the claims 3 to 14, wherein the post  
portion (5) has a maximum diameter (B) in the range 2 to 5 mm.

20

16. An abutment (1) according to any of the claims 3 to 15, wherein said  
shoulder portion (4) is having a maximum diameter (A) and said post portion (5) is  
having a maximum diameter (B) less than said maximum diameter (A) of the  
shoulder portion (4), the difference between said maximum diameters (A and B)  
25 being in the range 0.2 to 1 mm, preferably 0.5 mm.

17. An abutment (1) according to any of the claims 3 to 16, wherein an axial  
extension of said shoulder portion (4) is in the range 10% to 40 %, preferably 20 % to  
30 % of an axial extension of said component support region (3).

30

18. An abutment (1) according to any of the preceding claims, wherein said maximum diameter (A) of the component support region (3) coincides with the maximum diameter of the abutment (1).

5           19. An abutment according to any of the preceding claims, wherein said component engagement (9) forms part of a snap lock device.

20. An abutment according to any of the preceding claims, wherein said component engagement (9) comprises at least one protrusion or indentation in an  
10 outer surface (7, 8) of said component support region (3).

21. An abutment (1) according to claim 20, wherein said component engagement (9) comprises a groove or rib extending at least partly around a circumference of said outer surface (7, 8) of said component support region (3).  
15

22. An abutment (1) according to any of the previous claims, wherein said abutment (1) is further having an extension region (11) being provided between said implant contacting region (2) and said component support region (3).

20           23. An abutment (1) according to claim 22, wherein said extension region (11) has an outer surface (13) being parallel to a longitudinal axis (L) of said extension region (11) or being tapering outwardly in said coronal direction.

24. An abutment (1) according to any of the claims 22 to 23, wherein the  
25 transition between said extension region (11) and said component support region (3) defines said maximum diameter (A) of said component support region (3).

25. An abutment (1) according to claim 22 to 24, wherein said abutment (1) has a longitudinal axis (L), and the outer surface (13) of said extension region (11) is  
30 forming an angle ( $\varphi$ ) in the range  $90^\circ$  to  $180^\circ$  with said longitudinal axis.

26. An abutment (1) according to any of the claims 22 to 25, wherein an axial extension of said extension region (11) is in the range 10% to 50% as compared to an axial extension of said component support region (3).

5           27. An abutment (1) according to any of the preceding claims, wherein said implant contacting region (2) comprises a coronal contact portion (12) having an outer surface (14) tapering outwardly in a coronal direction of said abutment (1).

10           28. An abutment (1) according to claim 27, wherein said abutment (1) has a longitudinal axis (L), and said outer surface (14) of said coronal contact portion (12) is forming an angle ( $\omega$ ) with said longitudinal axis (L), said angle ( $\omega$ ) being in the range 165 to 170°, preferably 169°.

15           29. An abutment (1) according to any of the preceding claims, wherein said maximum diameter (A) of the component support region (3) is in the range 3 to 7 mm, preferably 3 to 6 mm.

20           30. An abutment (1) according to any of the preceding claims, wherein said component support region (3) is provided with at least one rotational lock (15) for rotationally locking of said dental component on said abutment (1).

31. An abutment (1) according to claim 30, wherein said rotational lock (15) is formed in the outer surface (7,8) of said component support region (3).

25           32. An abutment (1) according to claim 31, wherein said rotational lock means (15) is formed by a flat portion of said outer surface (7, 8) of said component support region (3).

30           33. An abutment (1) according to any of the preceding claims, wherein said implant contacting region (2) comprises an apical threaded shaft (16) for connection to internal threads of an implant.



34. An abutment (1) according to any of the preceding claims, wherein said abutment (1) is provided with a through bore (17) defining a ledge (18) for seating of a screw for connecting said abutment (1) to an implant.

5           35. An abutment (1) according to any of the preceding claims, wherein a polygonal blind bore (19) is extending from said coronal end (6) into the abutment (1), said polygonal blind bore (19) being useful for seating of a wrench tool when attaching the abutment (1) to an implant.

10           36. An abutment (1) according to any of the preceding claims, wherein said abutment is provided with at least one marking (20) positioned coronally of said component engagement means (9) for optional shortening of said abutment (1).

15           37. A series of abutments (1) according to any of the claims 1 to 36, each abutment having a maximum diameter (A) of said component support region (3), and said maximum diameter (A) being constant for all abutments in said series.

20           38. A series of abutments (1) according to any of the claims 3 to 36, when dependent on claim 3 or 4, wherein said angle ( $\alpha$ ) formed between said outer surface (8) of the post portion and said outer surface (7) of the shoulder portion (4) is constant for all abutments in said series.

25           39. A series of abutments according to any of the claims 3 to 36, each abutment having a longitudinal axis (L) and further comprising an implant contacting region (2) and an extension region (11) extending between said implant contacting region (2) and said component support region (3), wherein  
a longitudinal extension of said component support region (3) is constant between all abutments in said series, whereas a longitudinal extension of said extension region (11) varies between different abutments in said series.

30

40. A series of abutments (1) according to any of the claims 3 to 36, when dependent on claim 3 or 4, each abutment having a longitudinal axis (L) and further

comprising an implant contacting region (2) and an extension region (11) extending between said implant contacting region (2) and said component support region (3), wherein

5 - said extension region (11) presents an outer surface (13) forming an angle ( $\phi$ ) with said longitudinal axis (L),

- said shoulder portion (4) presenting an outer surface (7) tapering inwardly in a coronal direction and forming an angle ( $\chi$ ) with said longitudinal axis (L),

10 - said post portion (5) extending coronally from said shoulder portion (4) and presenting an outer surface (8) tapering inwardly in a coronal direction and forming an angle ( $\phi$ ) with said longitudinal axis (L) being less than the angle ( $\chi$ ) formed by the outer surface (7) of the shoulder portion (4) with said longitudinal axis (L), wherein,

said angle ( $\chi$ ) between the outer surface (7) of the shoulder portion (4) and the longitudinal axis (L) and said angle ( $\phi$ ) between the outer surface (8) of the post portion (5) and the longitudinal axis (L) are constant in all abutments in said series,

15 whereas the angle ( $\phi$ ) between the outer surface (13) of the said extension region (11) and said longitudinal axis (L) varies between different abutments in said series.

20 41. A series of abutments (1), each abutment having a component support region (3) comprising a post portion (5) having an outer surface (8) and a shoulder portion (4) having an outer surface (7) forming an angle ( $\alpha$ ) less than  $180^\circ$  with said outer surface (8) of the post portion (5) wherein said angle ( $\alpha$ ) less than  $180^\circ$  is constant for all abutments in said series.

25

42. A series of abutments, each abutment having a longitudinal axis (L) and further comprising an implant contacting region (2), a component support region (3) and an extension region (11) extending between said implant contacting region (2) and said component support region (3), wherein

30 a longitudinal extension of said component support region (3) is constant between all abutments in said series, whereas a longitudinal extension of said extension region (11) varies between different abutments in said series.

43. A series of abutments (1) for connection of a dental component to an implant, each abutment having a longitudinal axis (L) and comprising an implant contacting region (2), a component support region (3) and an extension region (11) there between, wherein

5

- said extension region (11) presents an outer surface (13) forming an angle ( $\phi$ ) with said longitudinal axis (L),
- said component support region (3) comprises a shoulder portion (4) presenting an outer surface (7) tapering inwardly in a coronal direction and forming an angle ( $\chi$ ) with said longitudinal axis (L),

10

and a post portion (5) extending coronally from said shoulder portion (4) and presenting an outer surface (8) tapering inwardly in a coronal direction and forming an angle ( $\phi$ ) with said longitudinal axis (L) being less than the angle ( $\chi$ ) formed by the outer surface (7) of the shoulder portion (4) with said longitudinal axis (L), wherein,

15

said angle ( $\chi$ ) between the outer surface (7) of the shoulder portion (4) and the longitudinal axis (L) and said angle ( $\phi$ ) between the outer surface (8) of the post portion (5) are constant in all abutments in said series,

20

whereas the angle ( $\phi$ ) between the outer surface (13) of the said extension region (11) and said longitudinal axis (L) varies between different abutments in said series.

44. An abutment replica (101), comprising a component support region (103) having the outer shape of the component support region (3) of an abutment (1) according to any of the claims 1 to 35, including replicated component engagement means (109)

25

45. An abutment replica (101) according to claim 44, wherein a bore (130) is extending from an apical end of said abutment replica (101) into the abutment replica (101), at least to a position coronally of said component engagement means (109).

30

46. An abutment replica (101) according to claim 44 or 45, wherein said bore (130) is a blind bore terminating at a position coronally of said component engagement means (109).

5           47. An abutment replica (101) according to any of the claims 44 to 46, wherein said abutment replica is provided with a marking (120) positioned coronally of said component engagement means (109) for optional shortening of said abutment replica (101).

10           48. An impression coping (201) for pick up impression making of a dental abutment (1) attached to a dental implant, comprising an abutment surrounding region (203), for surrounding said abutment (1), said abutment surrounding region (203) having a coronal end (206) and an apical end (240), and having an inner wall (207, 208) being provided with abutment engagement (209) being arranged for  
15           releasable engagement with said abutment (1) by linear displacement of said impression coping in relation to said abutment (1), said abutment engagement (209) being located closer to said apical end (240) than to said coronal end (206).

            49. An impression coping (201) according to claim 48, wherein said abutment  
20           surrounding region (203) comprises a shoulder contacting portion (204) having an inner wall (207) and a post surrounding portion (205) extending coronally from said shoulder contacting portion (204) and presenting an inner wall (208) forming an angle ( $\alpha$ ) larger than  $180^\circ$  with said inner wall (207) of said shoulder contacting portion (204), wherein said abutment engagement (209) is provided at the post surrounding  
25           portion (205), at a position being closer to the shoulder contacting portion (204) than to the coronal end (206) of the abutment surrounding region (203).

            50. An impression coping according to claim 49, wherein said abutment engagement means (209) is provided at a distance from said shoulder contacting  
30           portion (204) being less than 50% the distance between said shoulder contacting portion (204) and said coronal end (206), preferably less than 30 %, most preferred less than 20 %.

51. An impression coping according to claim 49 or 50, wherein said angle ( $\alpha$ ) is in the range 200 to 260°, preferably 210 to 240°, most preferred 220 to 230°.

5 52. An impression coping according to any of the claims 49 to 51, wherein said abutment engagement (209) is provided at a transition between said post surrounding portion (205) and said shoulder contacting portion (204).

53. An impression coping according to any of the claims 48 to 52, wherein  
10 said abutment engagement (209) forms part of a snap lock device.

54. An impression coping (201) according to any of the claims 48 to 53, wherein said abutment engagement (209) comprises at least one protrusion or indentation in an inner wall (207, 208) of said abutment surrounding region (203).  
15

55. An impression coping (201) according to claim 54, wherein said abutment engagement (209) comprises a groove or rib extending at least partly around a circumference of the inner wall (207, 208) of said abutment surrounding region (203).

20 56. An impression coping (201) according to any of the claims 48 to 55, said impression coping (201) having a through passage (217) extending from a coronal end to an apical end of the impression coping (201).

57. An impression coping (201) according to claim 56, said impression coping  
25 (201) having a longitudinal axis (L), wherein the inner walls (208) of said abutment surrounding region (203) comprises at least one abutment contact surface (243) for contact with said abutment (1), and at least one space forming surface (244) to be spaced apart from said abutment in order to provide a space between said space forming surface (244) and said abutment (1), and in a transversal section of said  
30 abutment surrounding region (203), a distance (r1) from said longitudinal axis (L) to said abutment contact surface (243) is shorter than a distance (r2) from said longitudinal axis (L) to said space forming surface (244).

58. An impression coping (201) according to claim 57, wherein said space forming surface (244) is provided with a vent (245) for passage of air and/or impression material.

5

59. An impression coping (201) according to claim 57 or 58, wherein at least one abutment contact surface (243) is tapering inwardly in a coronal direction of said impression coping (201).

10

60. An impression coping (201) according to claim 59, wherein said at least one abutment contact surface (243) is forming an angle of taper of less than 20°, preferably less than 15°, most preferred 6° with a longitudinal axis of said impression coping (201).

15

61. An impression coping (201) according to any of the claims 57 to 60, wherein at least one abutment contact surface (243) is provided with a rotational locking means (215), for rotational locking of said impression coping (201) on said dental abutment (1).

20

62. An impression coping (201) according to claim 61, wherein said rotational locking means (215) is formed by a flat portion of said abutment contact surface (243).

25

63. An impression coping (201) according to any of the claims 57 to 62, wherein at least one space forming surface (244) is provided coronally of said abutment engagement means (209).

30

64. An impression coping (201) according to any of the claims 57 to 63, having at least two abutment contact surfaces (243) arranged to face each other, and two space forming surfaces (244) being arranged between said abutment contact surfaces (243), also facing each other.

65. An impression coping (201) according to any of the claims 48 to 64, having a prolongation region (241) being provided coronally of said abutment surrounding region (203), for extension into an impression material.

5           66. An impression coping (201) according to claim 65, wherein said prolongation region (241) is provided with retention elements (242) for retention of the impression coping (201) in an impression material.

67. A set, comprising an abutment (1) for connection of a dental component to  
10 an implant and an impression coping (201) for pick-up impression making of said abutment (1),

          said abutment (1) comprising an implant contacting region (2) and a component support region (3) having a maximum diameter (A), said component support region (3) extending coronally from said maximum diameter (A) to a coronal  
15 end (6), and being provided with component engagement (9) at a position closer to said maximum diameter (A) than to said coronal end (6), and

          said impression coping (201) comprising an abutment surrounding region (203) for surrounding said abutment (1) and having an inner wall (208) being provided with abutment engagement (209) corresponding to the component  
20 engagement (9) of said abutment (1) for releasable engagement of the impression coping (201) to the abutment (1) by linear displacement of said dental component in relation to said abutment (1).

68. A set according to claim 67, wherein a maximum outer diameter of an  
25 abutment contacting portion (203) of said impression coping (201) is less than or equal to said maximum diameter (A) of said abutment (1).

69. A set according to claim 67 or 68, wherein said abutment (1) comprises an implant contacting region (2) and a component support region (3),  
30

          and said impression coping (201) is having a through passage extending from a coronal end to an apical end of said impression coping (201)

and comprises an abutment surrounding region (203) for seating on said abutment (1), wherein the inner walls (207, 208) of said abutment surrounding region (203) comprise at least one post contact surface (243) for contact with said abutment (1) and at least one space forming surface (244) to be spaced apart from said abutment  
5 (1) in order to provide a space for optional introduction of impression material between said space forming surface (244) and said abutment (1).



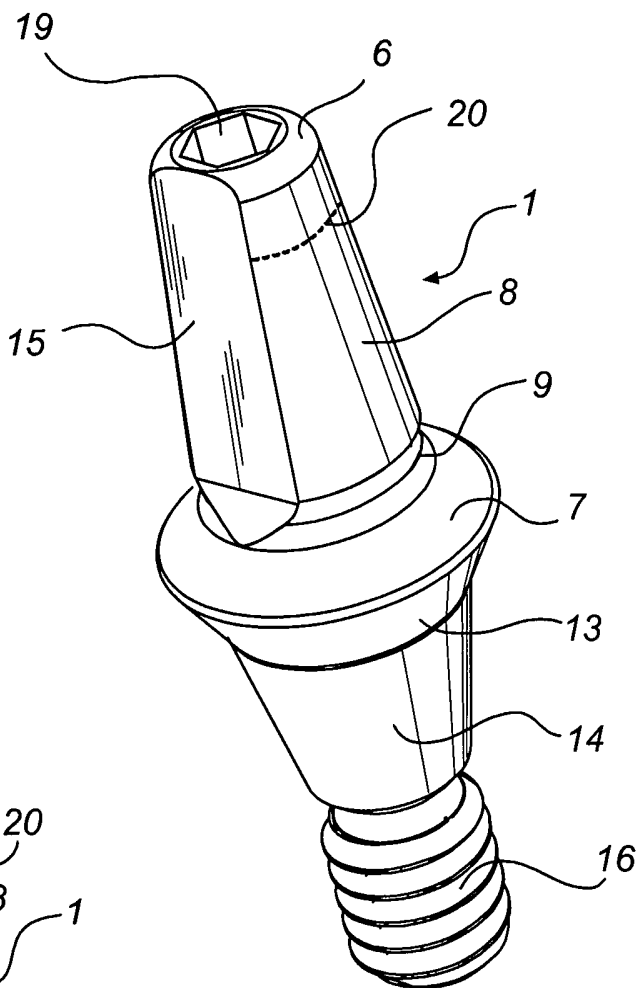

Fig. 1a

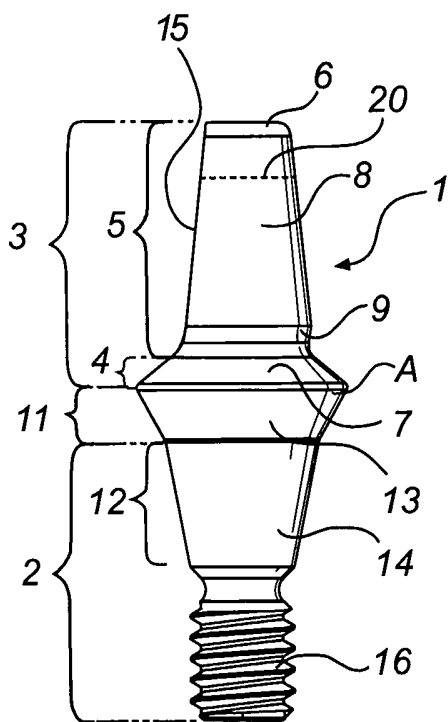

Fig. 1b

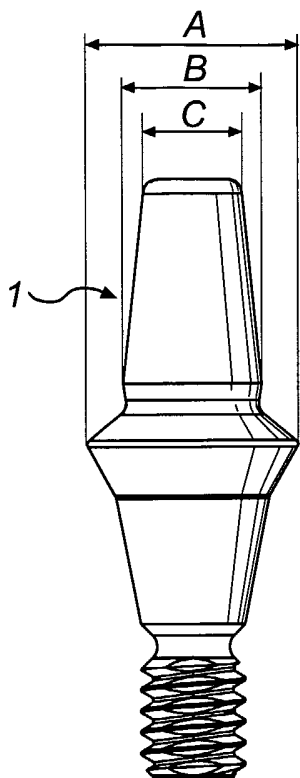

Fig. 1c

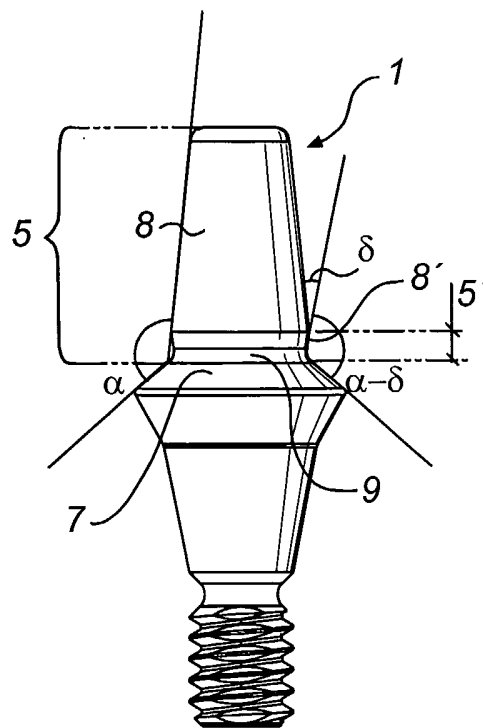

Fig. 1e

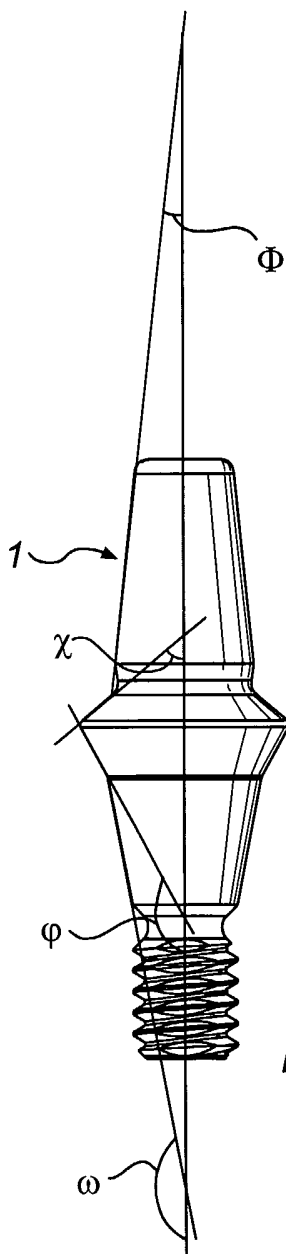

Fig. 1d

3/18

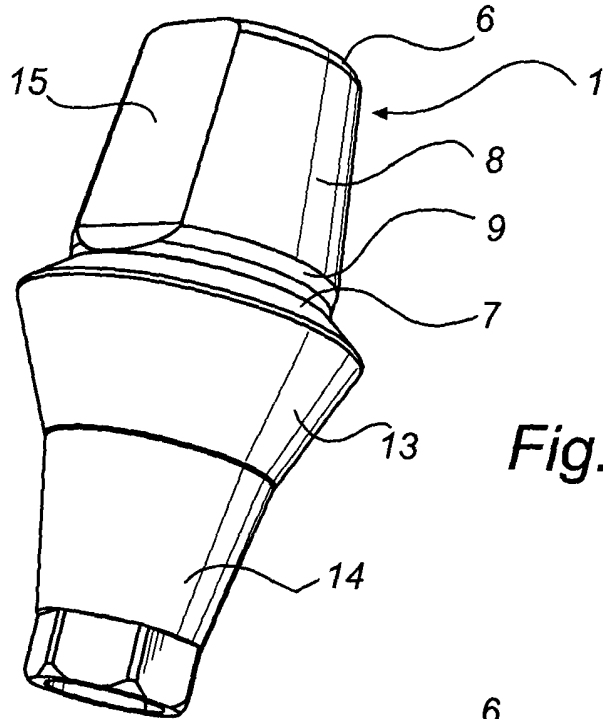

Fig. 2a

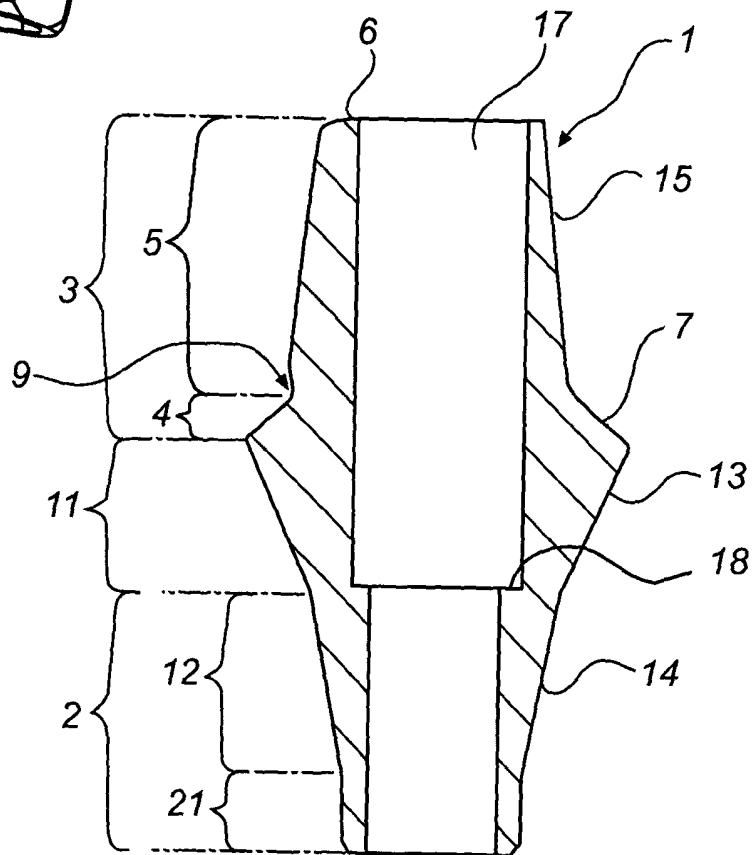

Fig. 2b

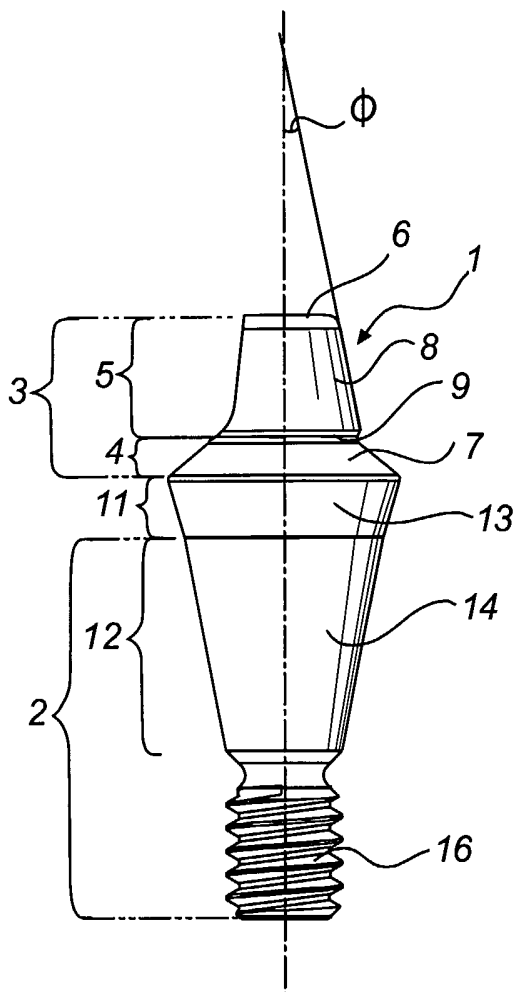

Fig. 3

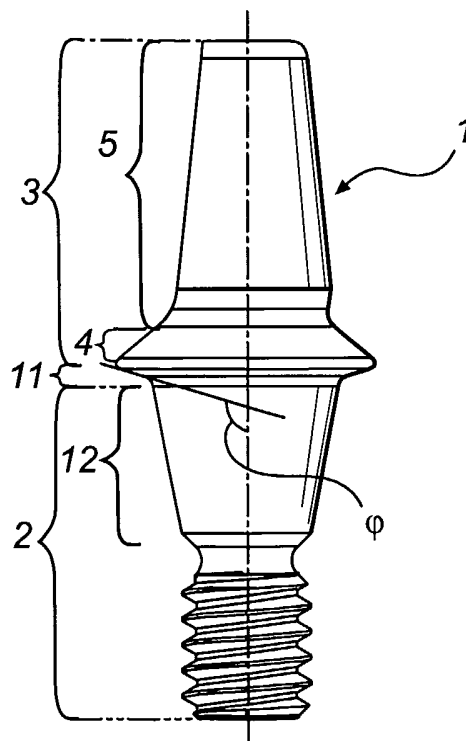
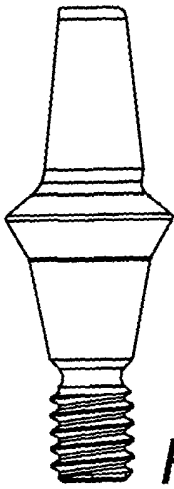
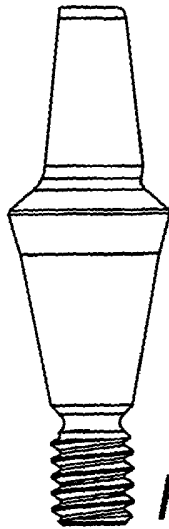

Fig. 4

5/18



*Fig. 5a*



*Fig. 5b*

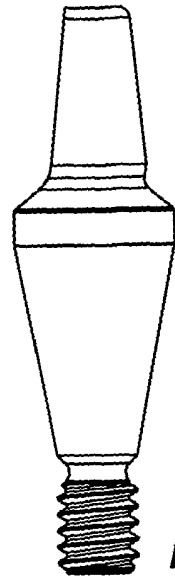

*Fig. 5c*

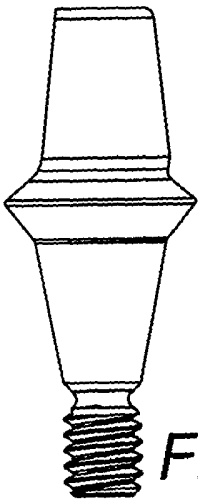

*Fig. 5d*

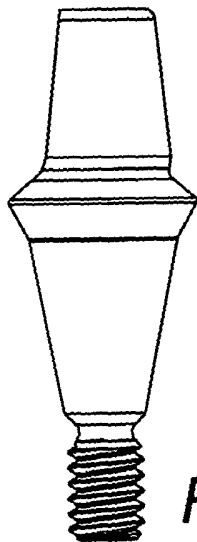

*Fig. 5e*

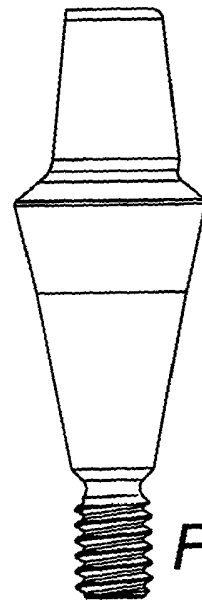

*Fig. 5f*

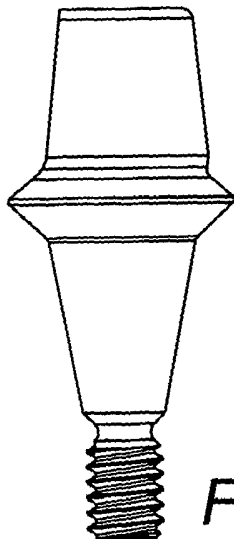

*Fig. 5g*

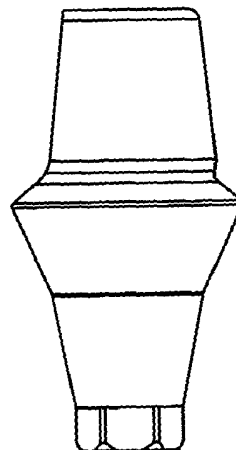

*Fig. 5h*

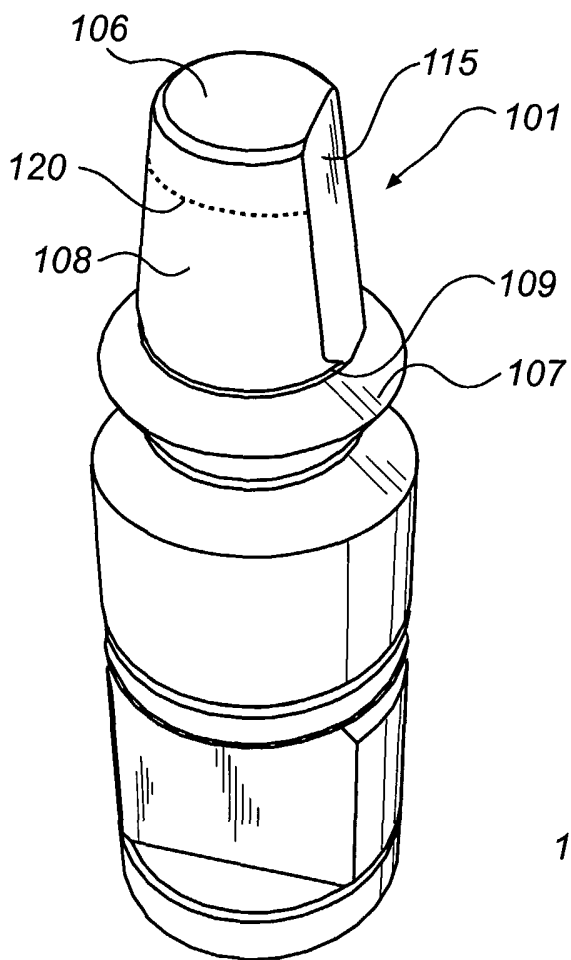

Fig. 6a

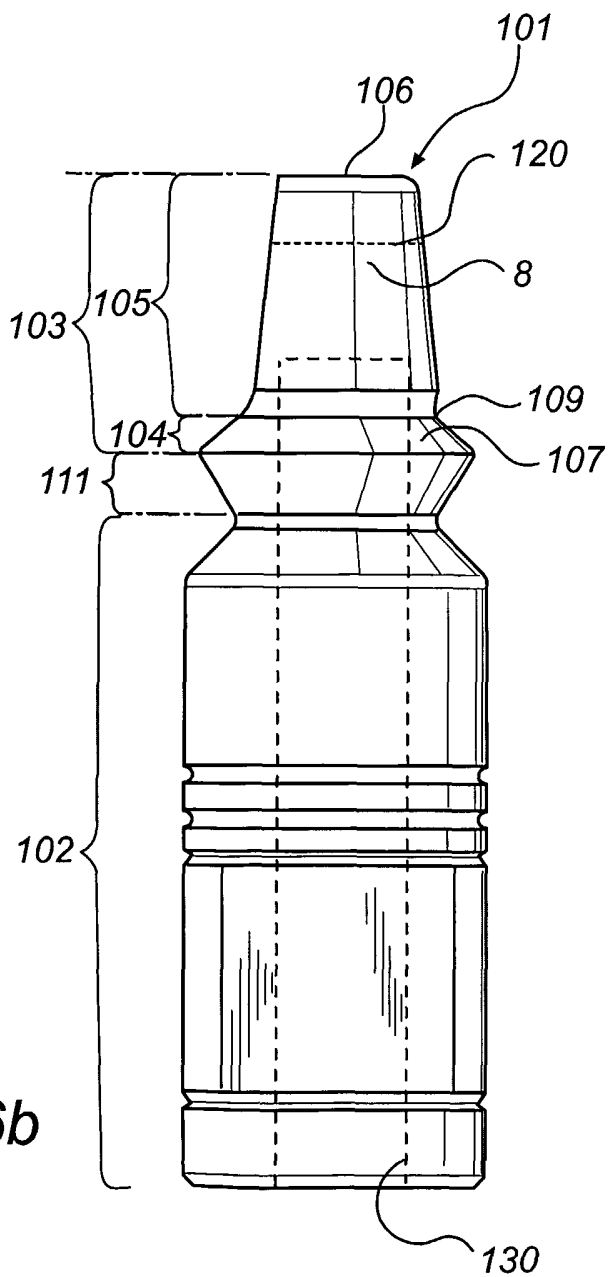

Fig. 6b

7/18

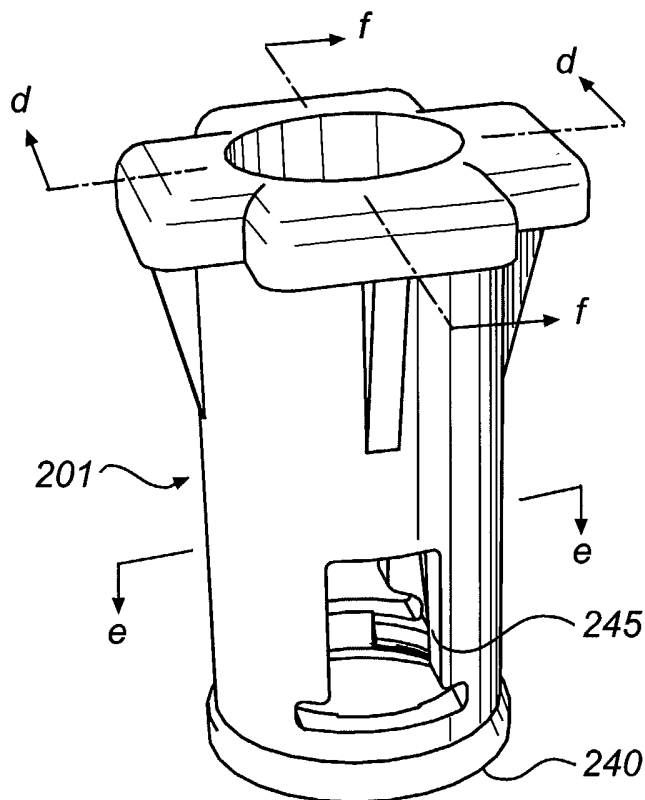

Fig. 7a

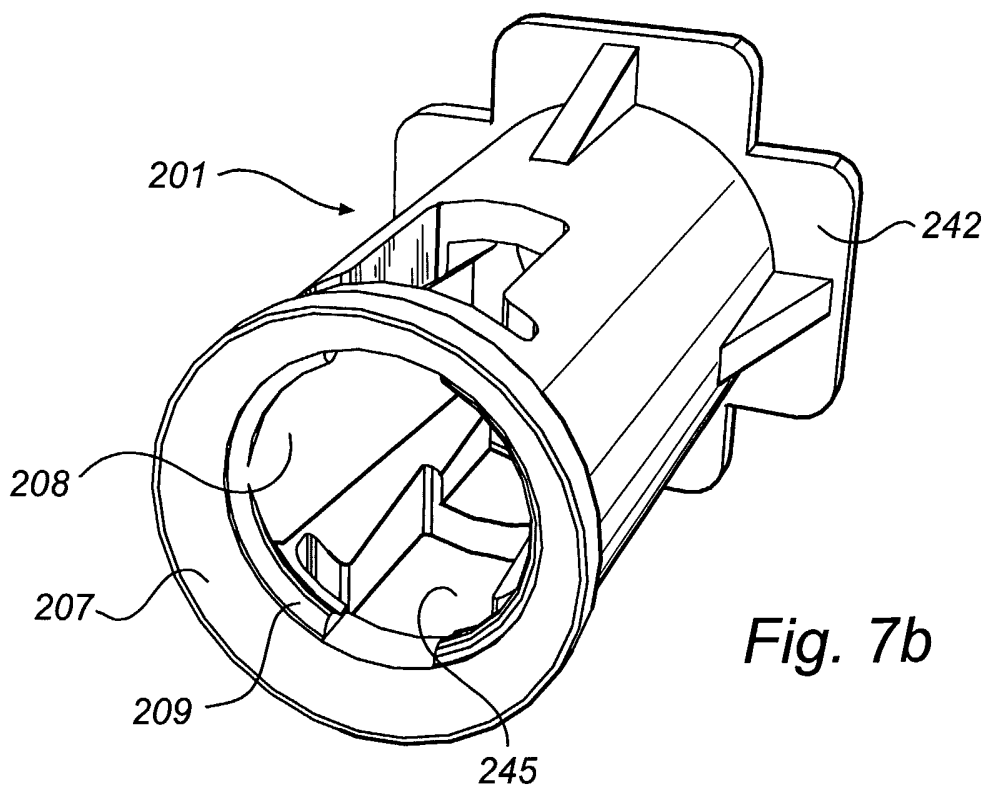

Fig. 7b

8/18

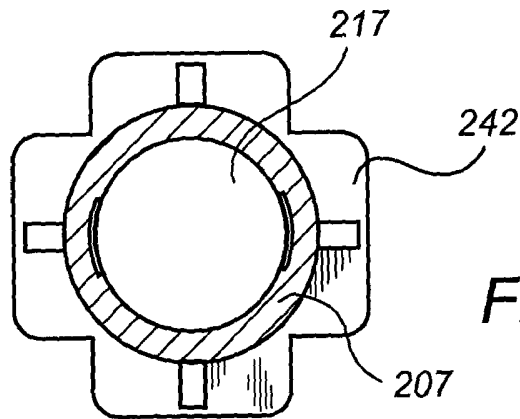

Fig. 7c

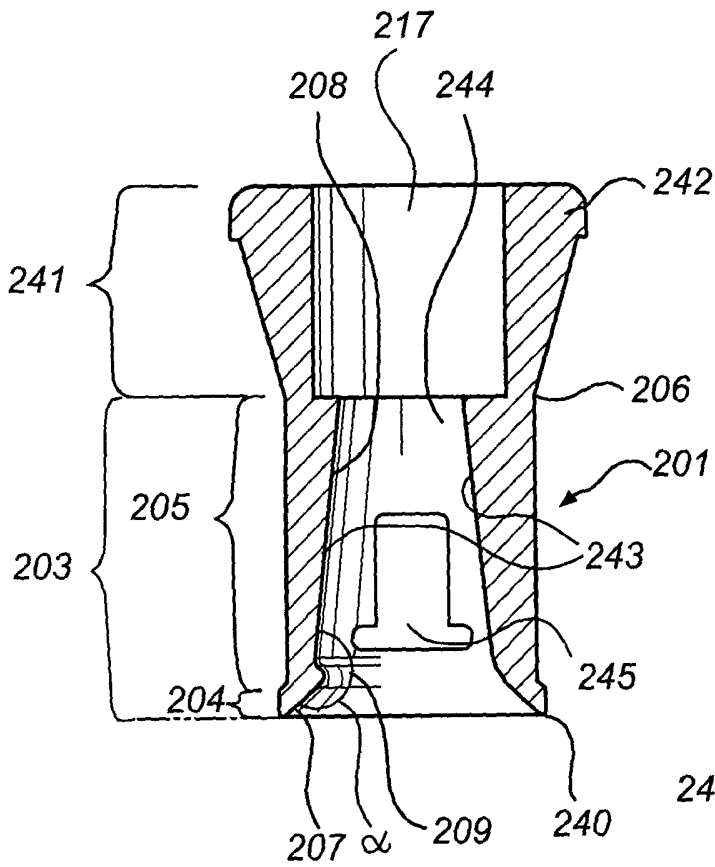

Fig. 7d

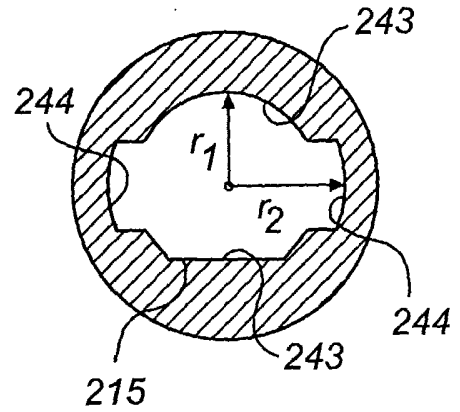

Fig. 7e

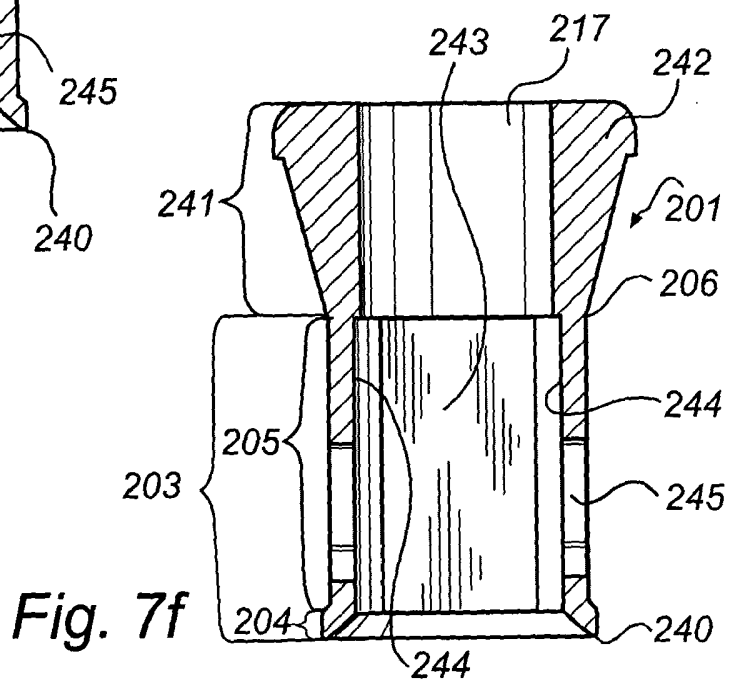

Fig. 7f



9/18

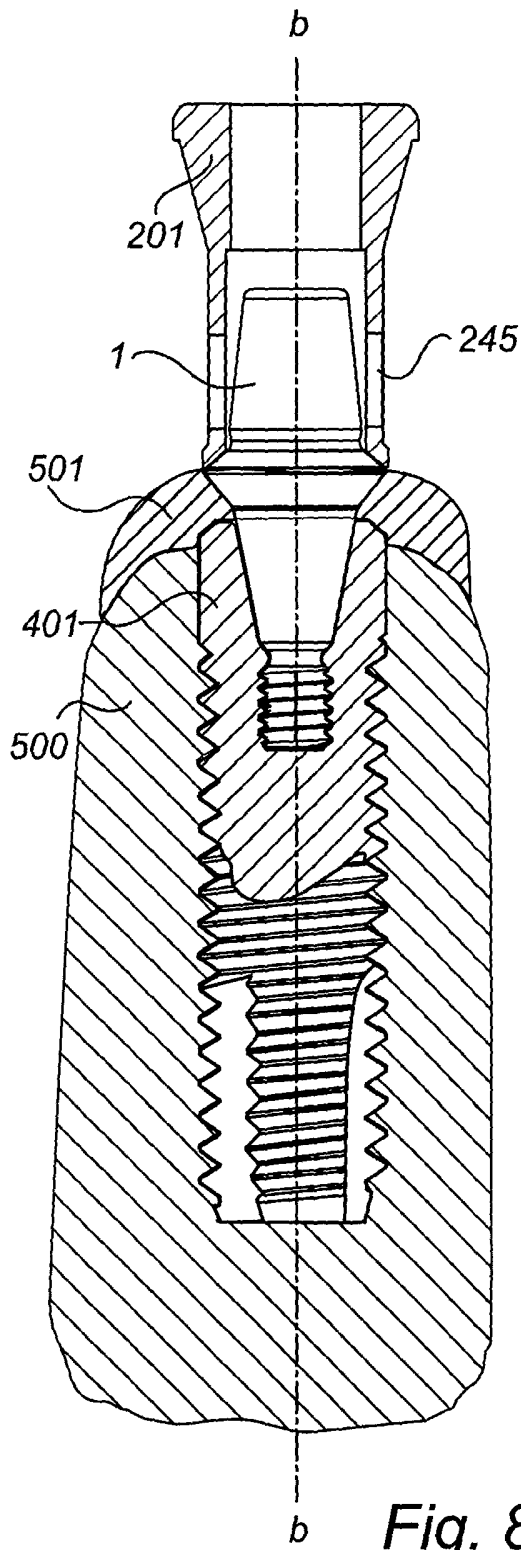

Fig. 8a

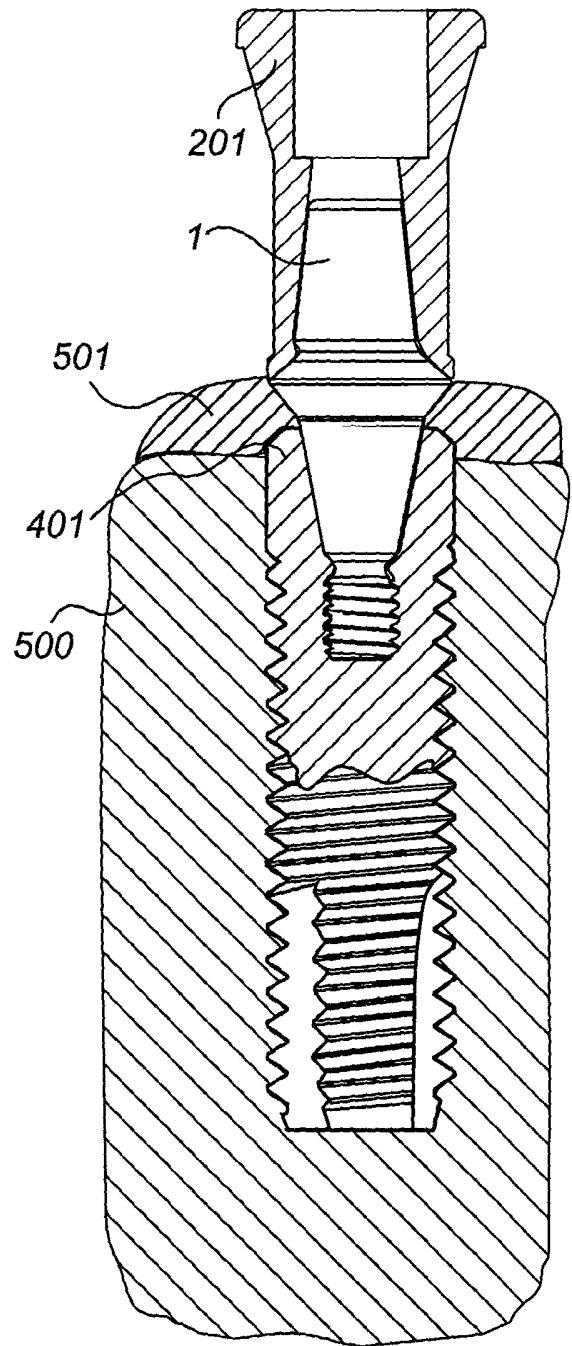
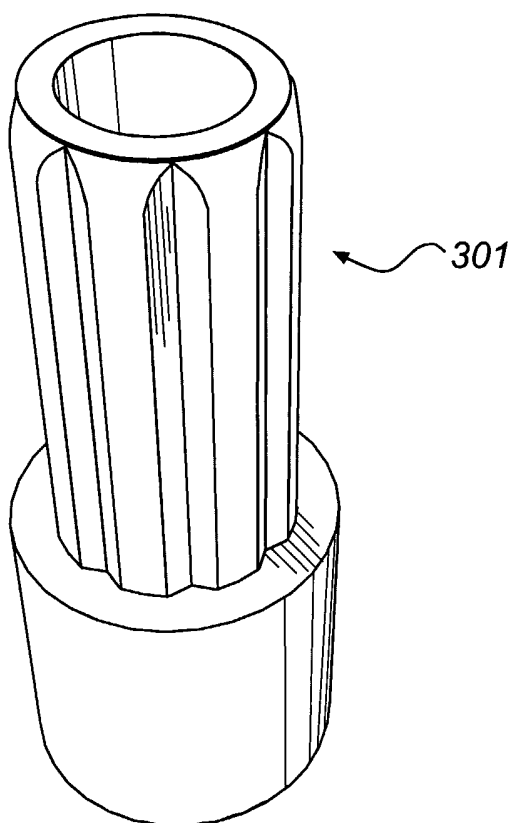
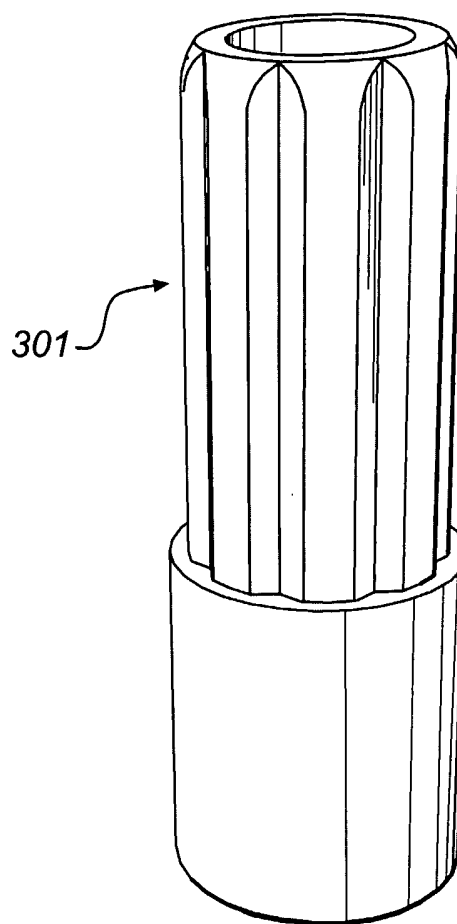

Fig. 8b

10/18



*Fig. 9a*



*Fig. 9b*

11/18

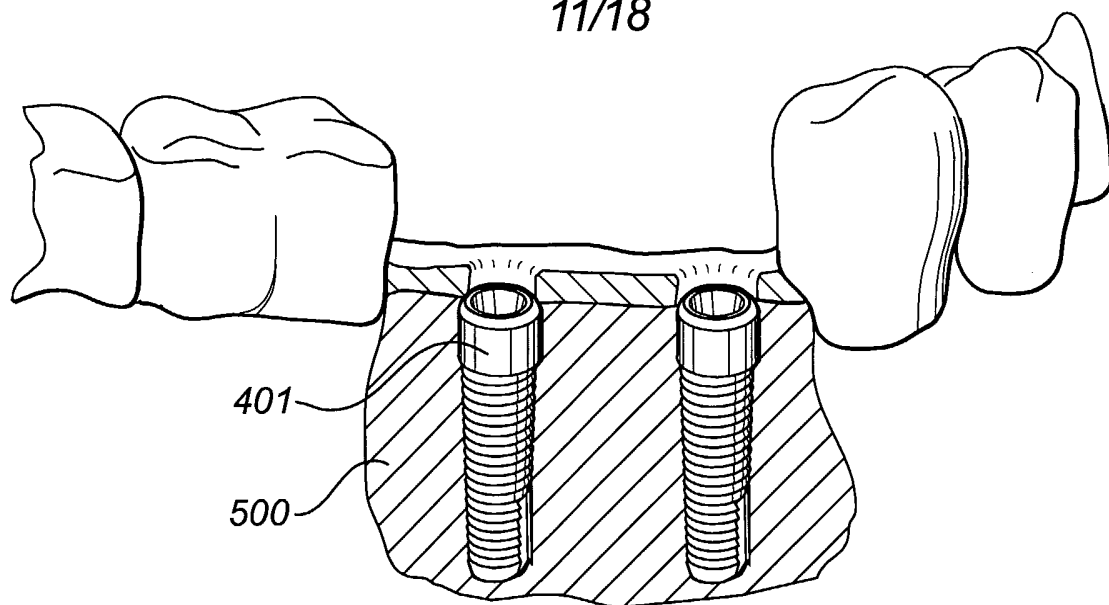

Fig. 10a

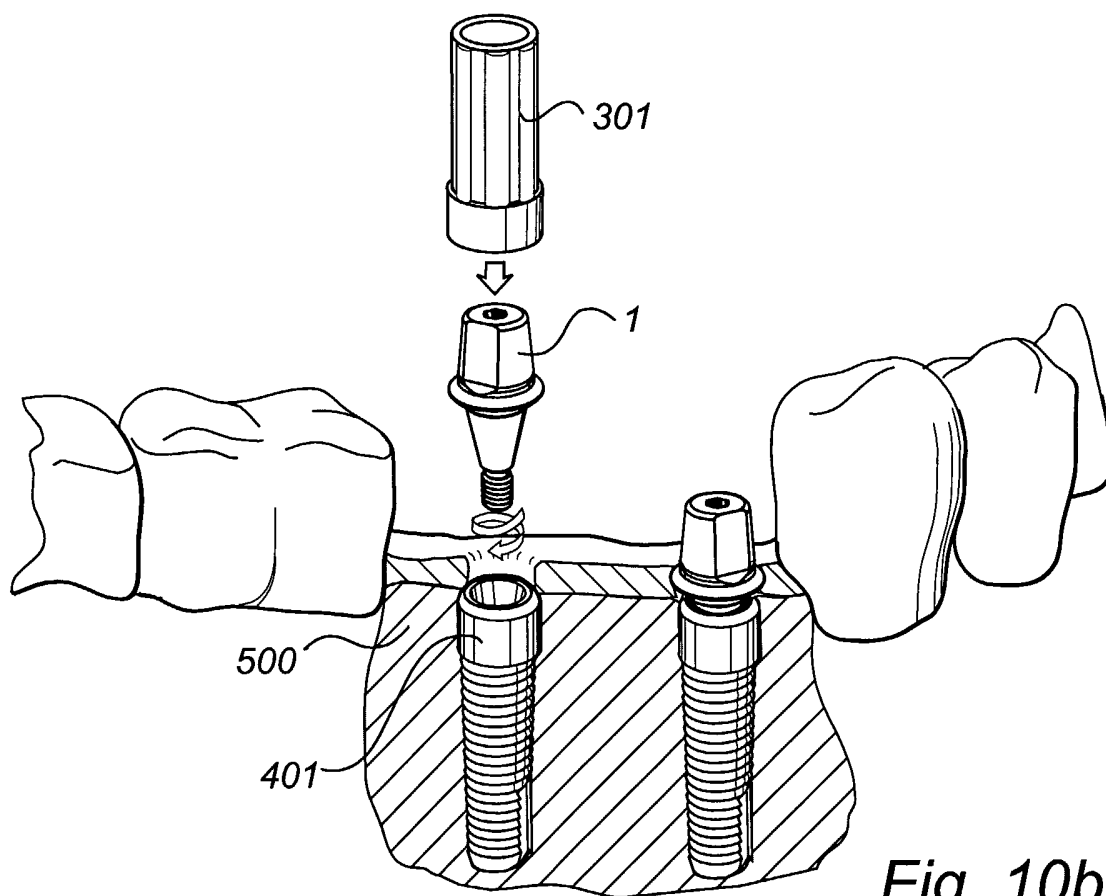

Fig. 10b

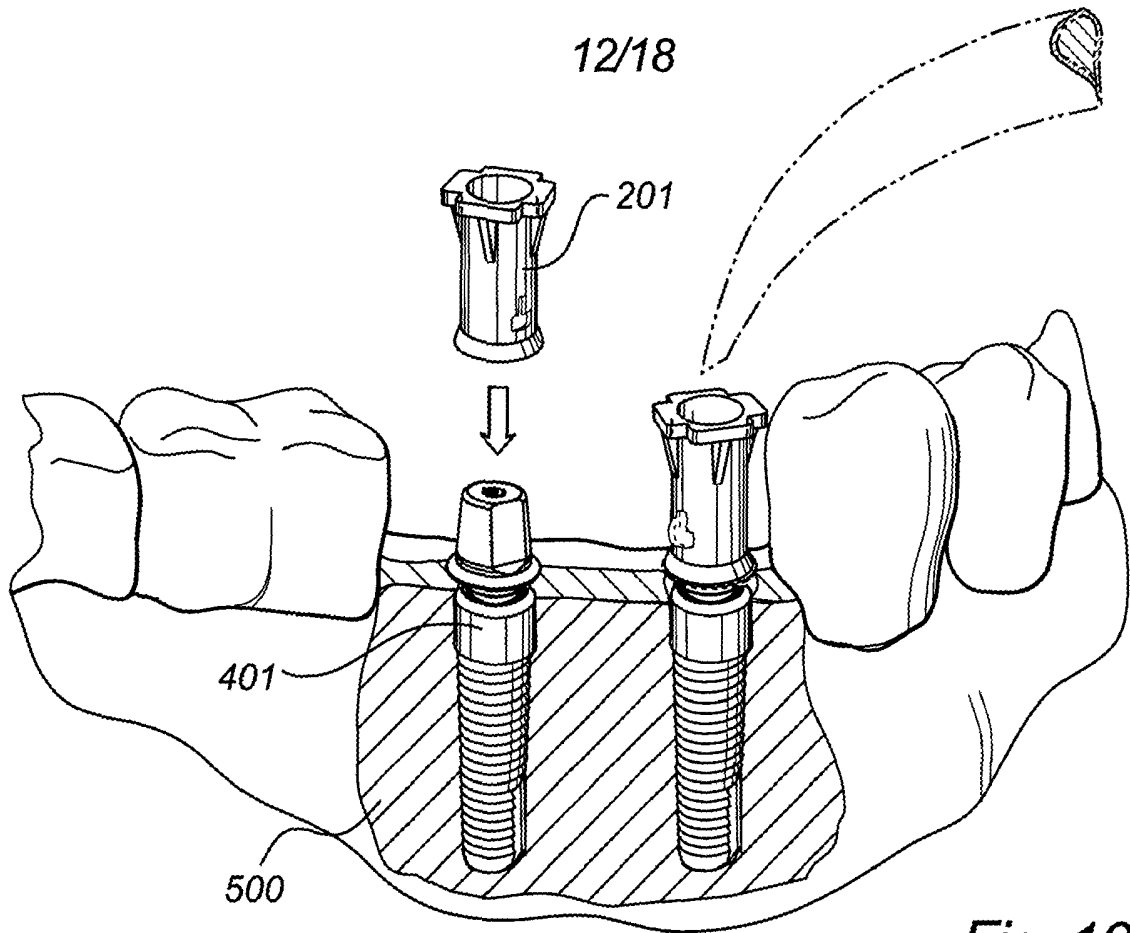

Fig. 10c

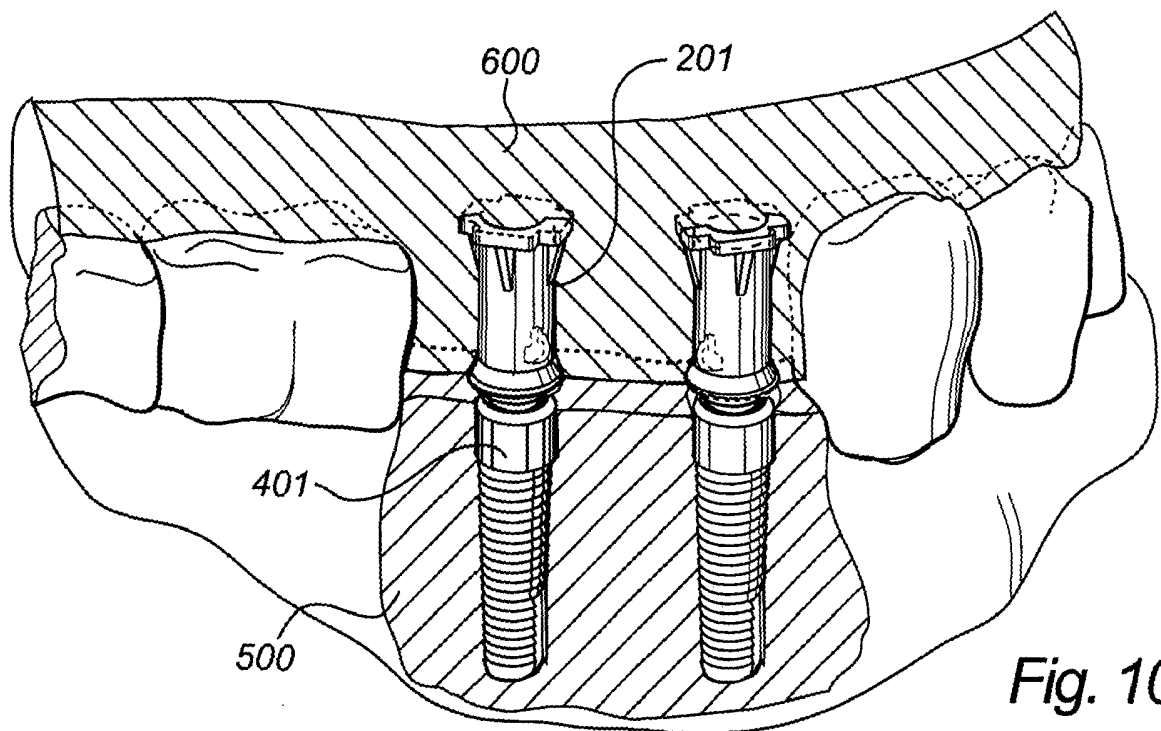

Fig. 10d

13/18

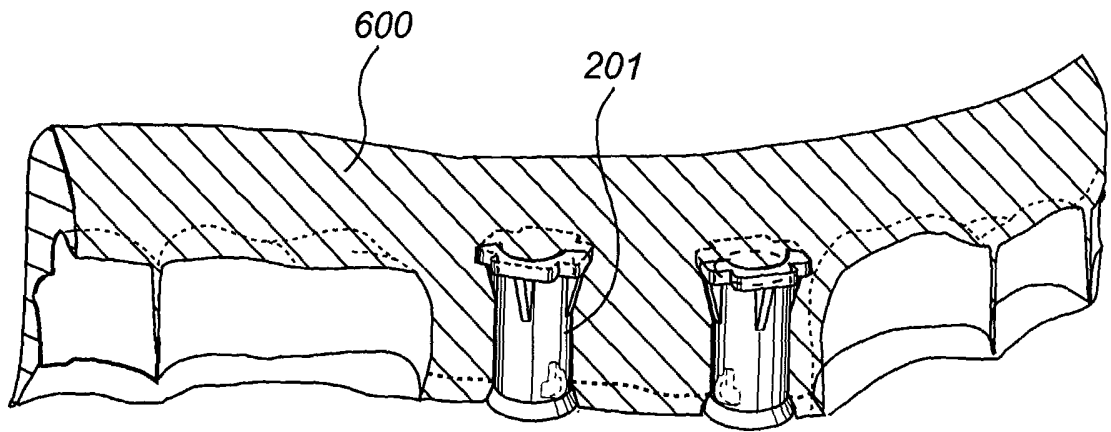

Fig. 10e

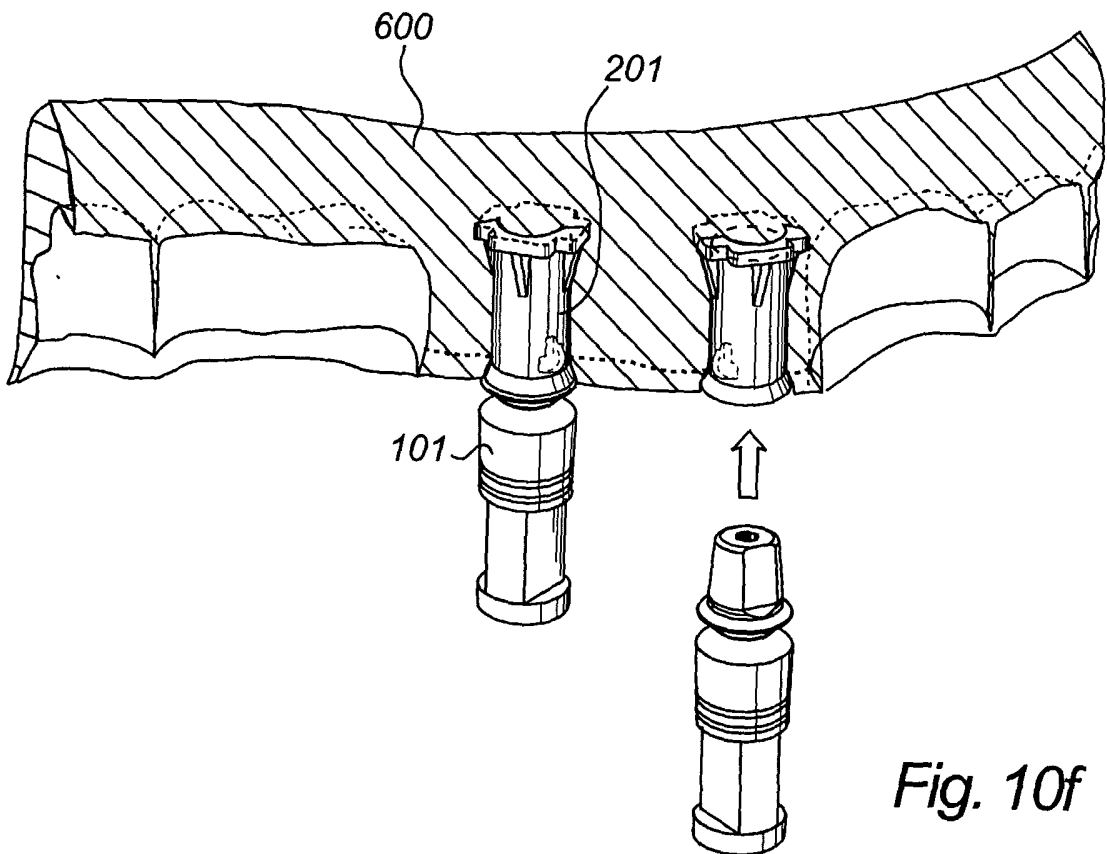

Fig. 10f

14/18

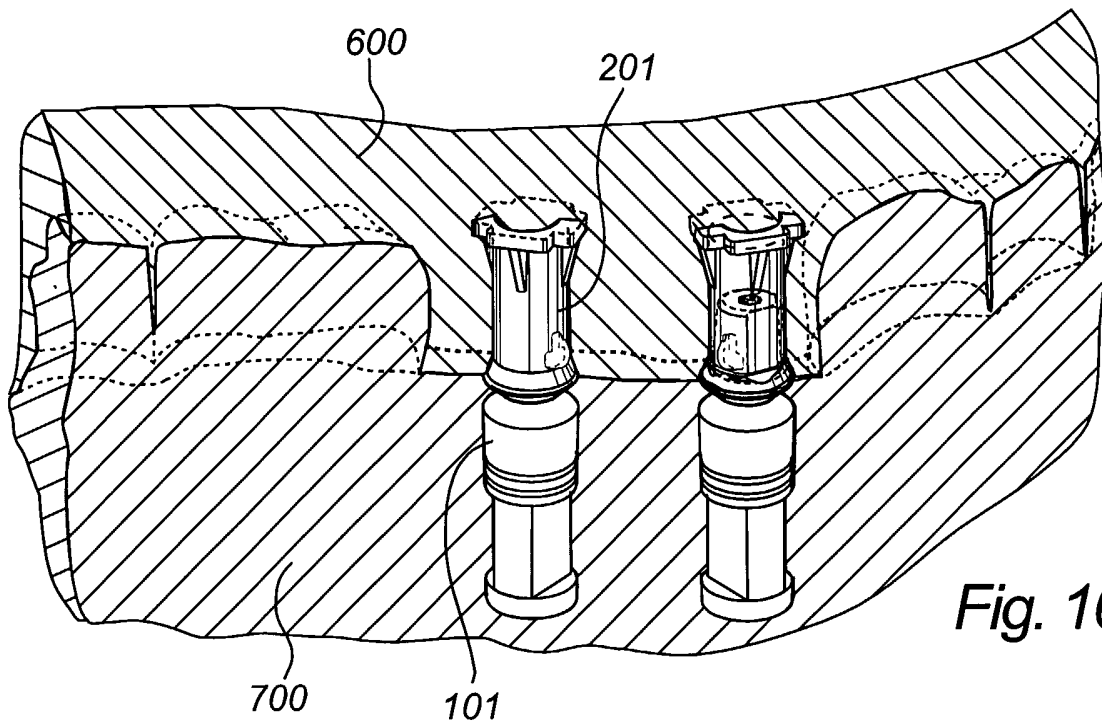

Fig. 10g

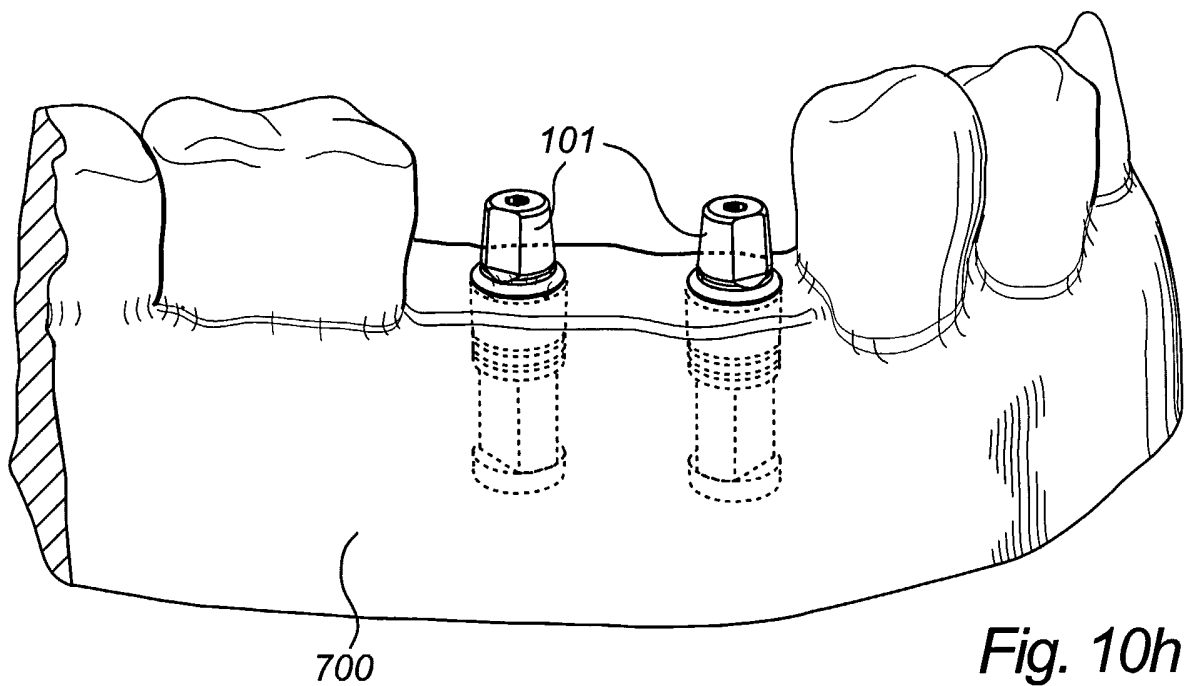

Fig. 10h

15/18

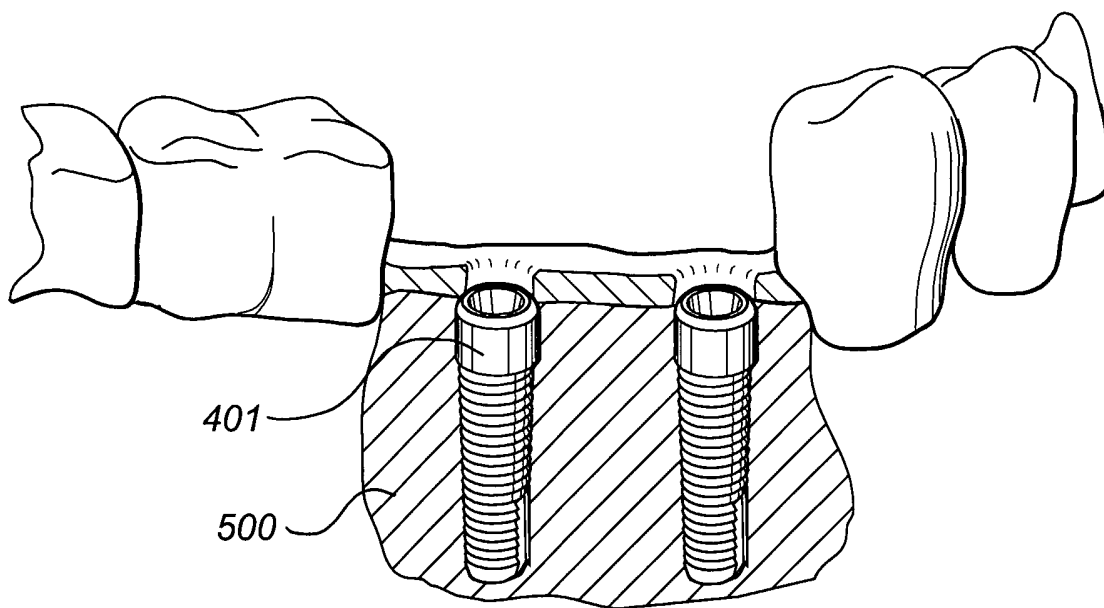

Fig. 11a

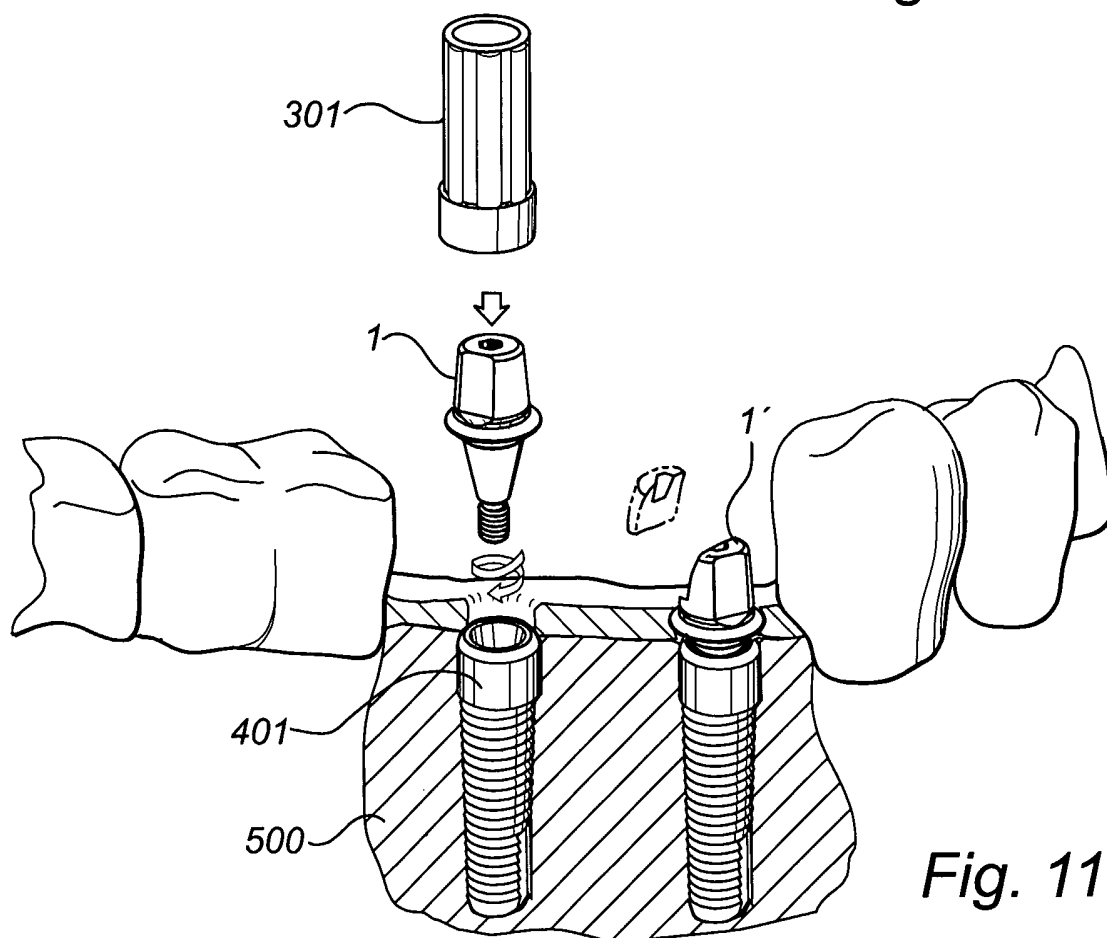

Fig. 11 b

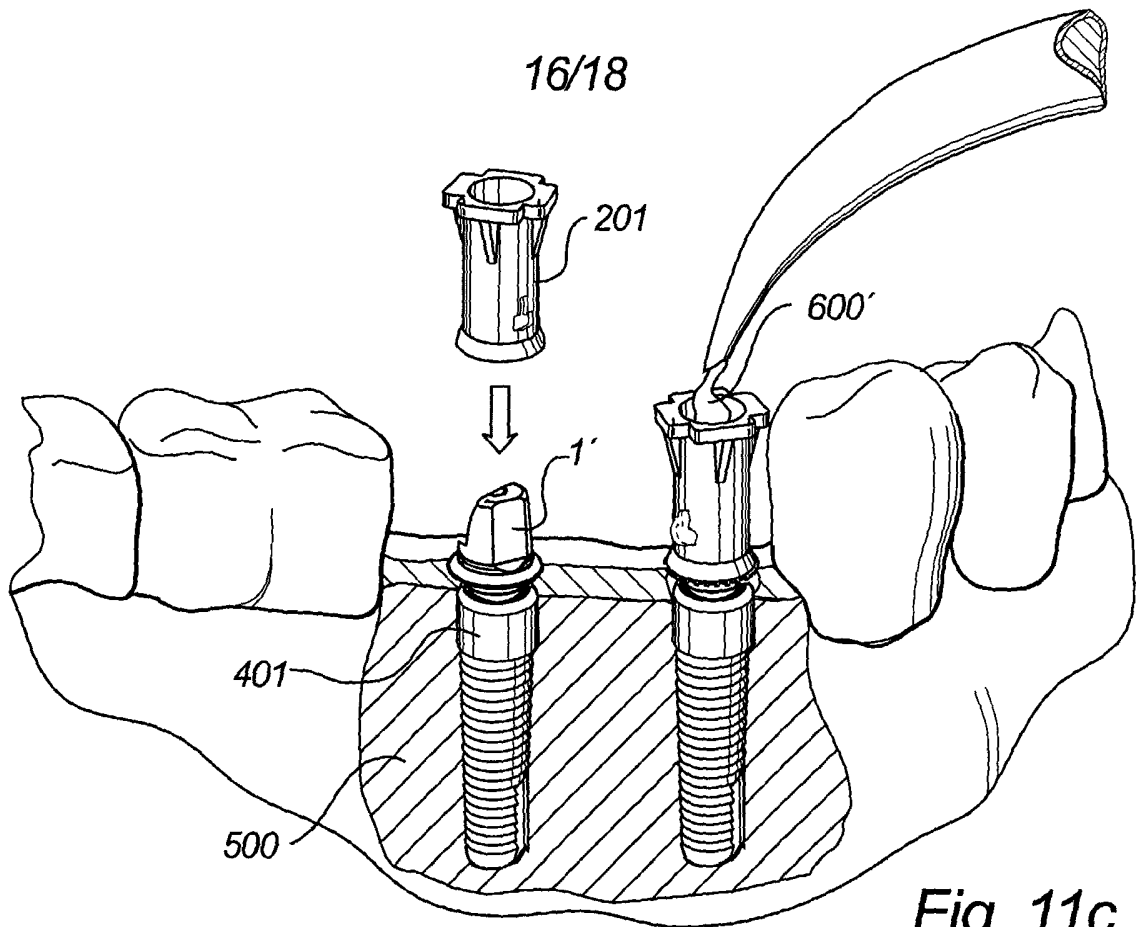

Fig. 11c

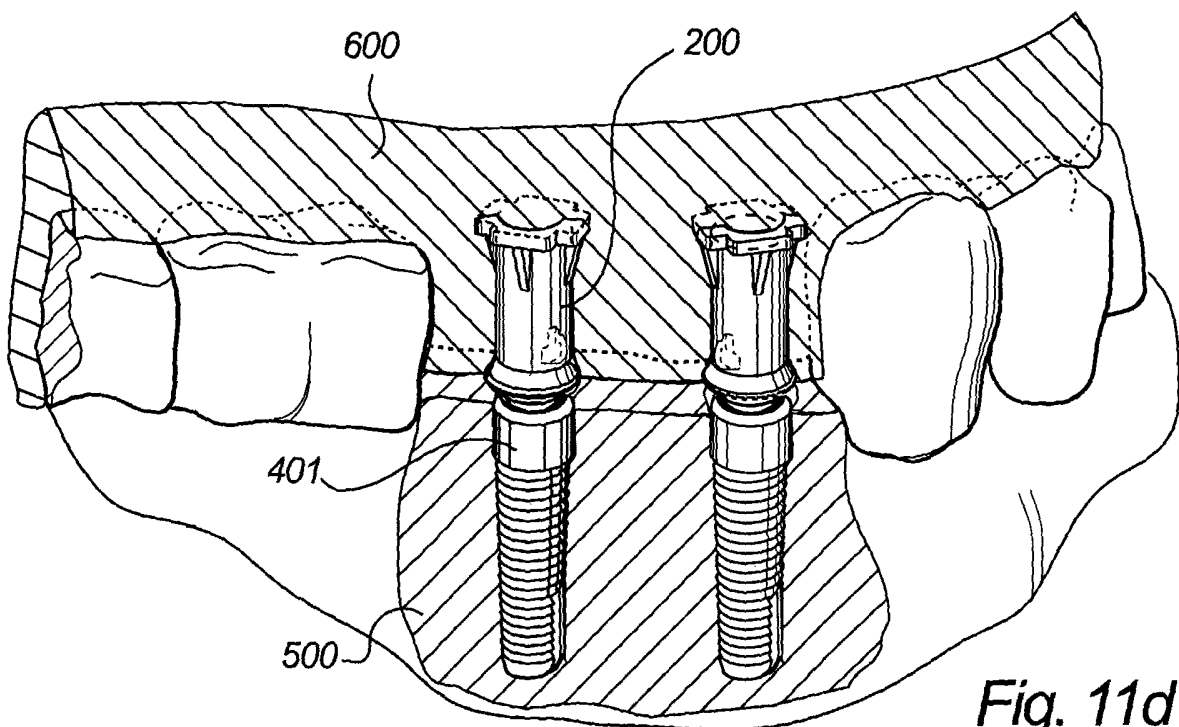

Fig. 11d



17/18

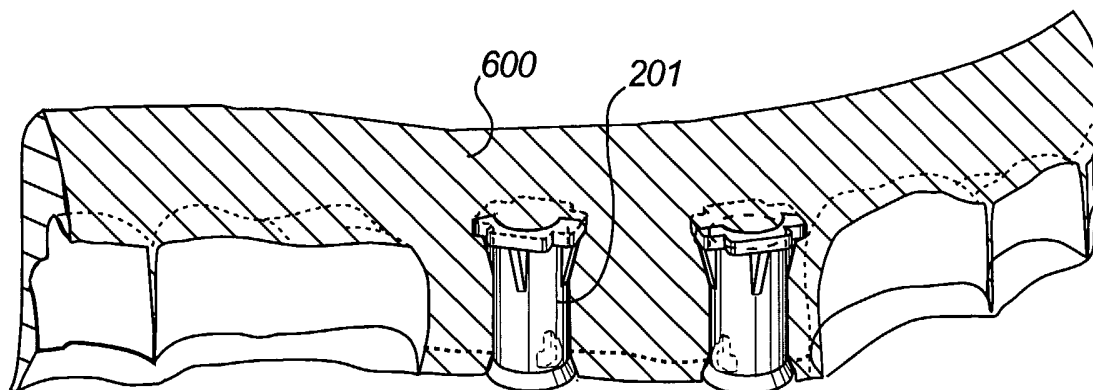

Fig. 11 e

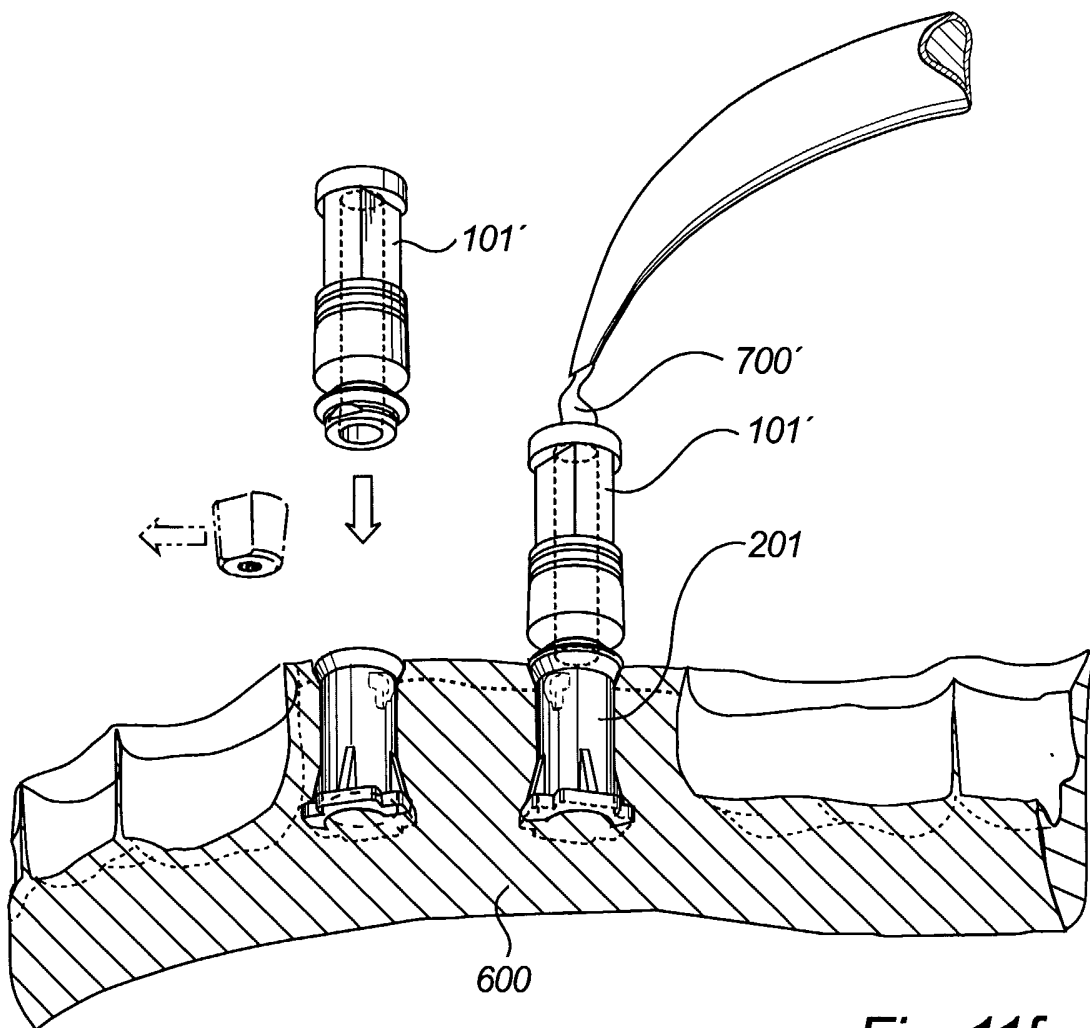

Fig. 11f

18/18

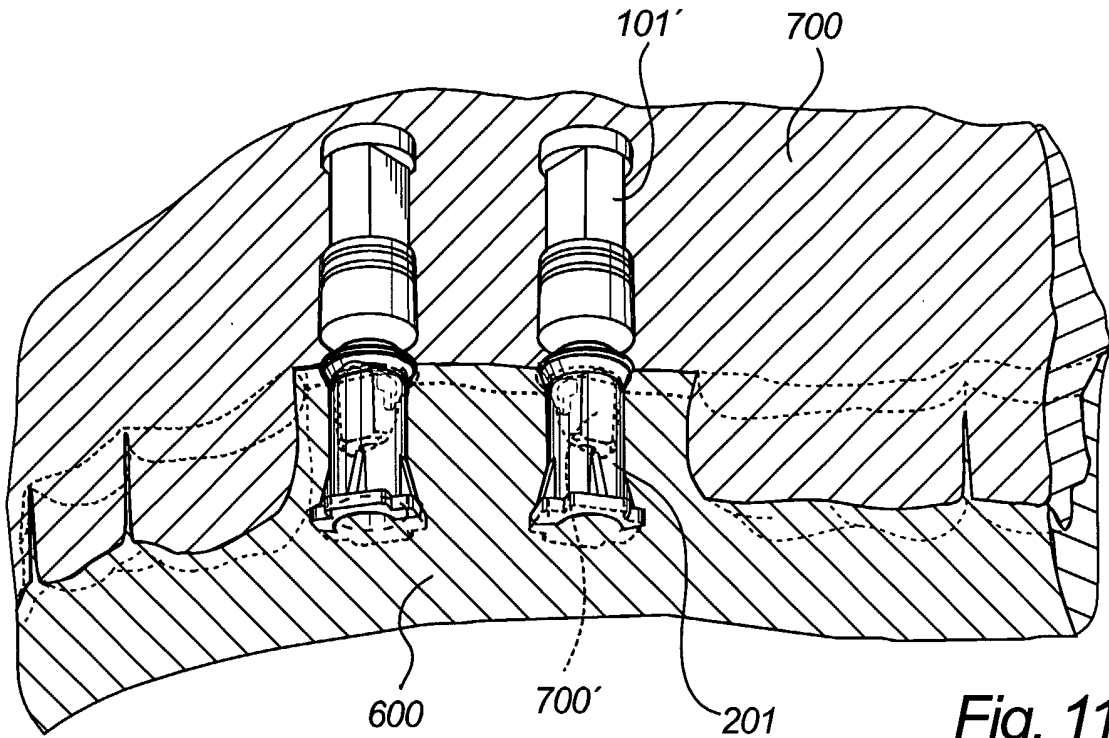

Fig. 11g

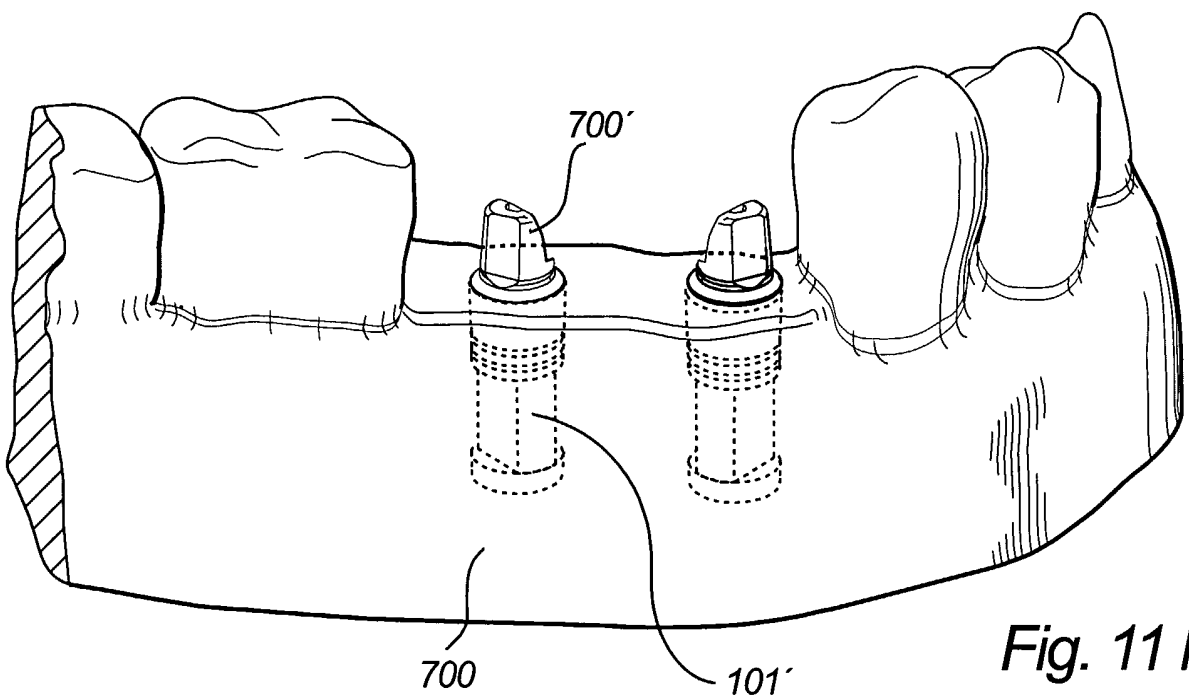

Fig. 11 h

## INTERNATIONAL SEARCH REPORT

International application No.

PCT/SE 02/01995

## A. CLASSIFICATION OF SUBJECT MATTER

IPC7: A61C 8/00

According to International Patent Classification (IPC) or to both national classification and IPC

## B. FIELDS SEARCHED

Minimum documentation searched (classification system followed by classification symbols)

IPC7: A61C

Documentation searched other than minimum documentation to the extent that such documents are included in the fields searched

SE,DK,FI,NO classes as above

Electronic data base consulted during the international search (name of data base and, where practicable, search terms used)

## C. DOCUMENTS CONSIDERED TO BE RELEVANT

Category*	Citation of document, with indication, where appropriate, of the relevant passages	Relevant to claim No.
A	US 6068478 A (VINCENZO GRANDE ET AL), 30 May 2000 (30.05.00)  --	1-69
A	US 6159010 A (DAN PAUL ROGERS ET AL), 12 December 2000 (12.12.00)  -- -----	1-69

 Further documents are listed in the continuation of Box C. See patent family annex.

\* Special categories of cited documents:

"A" document defining the general state of the art which is not considered to be of particular relevance

"E" earlier application or patent but published on or after the international filing date

"L" document which may throw doubts on priority claim(s) or which is cited to establish the publication date of another citation or other special reason (as specified)

"O" document referring to an oral disclosure, use, exhibition or other means

"P" document published prior to the international filing date but later than the priority date claimed

"T" later document published after the international filing date or priority date and not in conflict with the application but cited to understand the principle or theory underlying the invention

"X" document of particular relevance: the claimed invention cannot be considered novel or cannot be considered to involve an inventive step when the document is taken alone

"Y" document of particular relevance: the claimed invention cannot be considered to involve an inventive step when the document is combined with one or more other such documents, such combination being obvious to a person skilled in the art

"&amp;" document member of the same patent family

Date of the actual completion of the international search

12 February 2003

Date of mailing of the international search report

13-02-2003

Name and mailing address of the ISA/

Swedish Patent Office

Box 5055, S-102 42 STOCKHOLM

Facsimile No. +46 8 666 02 86

Authorized officer

Jack Hedlund/Els

Telephone No. +46 8 782 25 00

## INTERNATIONAL SEARCH REPORT

Information on patent family members

30/12/02

International application No.

PCT/SE 02/01995

Patent document cited in search report			Publication date	Patent family member(s)		Publication date
US	6068478	A	30/05/00	AT	185060 T	15/10/99
				AU	708386 B	05/08/99
				AU	1435497 A	28/08/97
				BR	9706645 A	12/01/99
				CA	2230615 A	14/08/97
				DE	59700503 D	00/00/00
				EP	0879024 A,B	25/11/98
				SE	0879024 T3	
				ES	2137046 T	01/12/99
				IL	123396 D	00/00/00
				JP	3290995 B	10/06/02
				JP	11503655 T	30/03/99
				WO	9728755 A	14/08/97
				DK	879024 T	27/03/00
US	6159010	A	12/12/00	EP	0951876 A	27/10/99
				US	5929234 A	27/07/99